



**BETTIS™**

**TorqPlus™**  
Electric Valve  
Actuators  
and Controls



**EMERSON.**  
Process Management

**EMERSON. CONSIDER IT SOLVED.™**



Torque 2,000 IN/LB – 20,000 IN/LB

### The Engineered Solution

Bettis TorqPlus quality line of electric actuators are designed for quarter turn applications — ball, butterfly and plug valves; dampers; vents and similar uses. TorqPlus actuators are manufactured in a wide range of **guaranteed** output torques and operating speeds to fit your specific requirements.

The EM-800 Series utilizes a highly effective planetary gearing system and a handwheel manual override to produce maximum torques in a compact package.



### STANDARD FEATURES

- Two year warranty
- Heater and thermostat installed in all actuators
- Case hardened steel spur gear train is permanently lubricated
- Operating temperatures:
  - 40° F with standard heater activated, to +140° F
- Single phase capacitor run motor with thermal overload protection

- Enclosure certified to weatherproof C.S.A. specifications that conform to NEMA type 1, 2, 3, 3R, 4 and 12
- Handwheel manual operation
- Mechanical position indicator
- Captive hex bolts on enclosure
- Dual 3/4-inch NPT machined conduit entrances
- Two single pole double throw travel-stop limit switches with adjustable cams and 2 aux S.P.D.T.
- Female drive
- Weight: 65-70 lbs (type 4), 150-160 lbs (explosion-proof)
- Two mechanical torque limit switches

### OPTIONAL FEATURES

- Dual purpose weatherproof and explosion-proof enclosures are certified by Canadian Standards Association for services: Class I Groups C,D, Division I; Class II Groups E,F,G Division I that conform to NEMA type 7 and 9
- Standard 1K potentiometer, other ranges provided upon request
- Electronic proportional positioner for 4-20 mA, 1-5 vDC, or 0-10 vDC control input and 4-20mA output signal
- Optional voltages
  - 220 VAC 50/60 Hz single phase
  - 220 VAC 50/60 Hz 3 phase
- Relay control
- Maximum of four additional single pole double throw auxiliary limit switches with adjustable cams
- Electromechanical brake
- Canadian Standards Association general purpose for electrical certification available under file #LR90062



Torque 2,000 IN/LB – 20,000 IN/LB

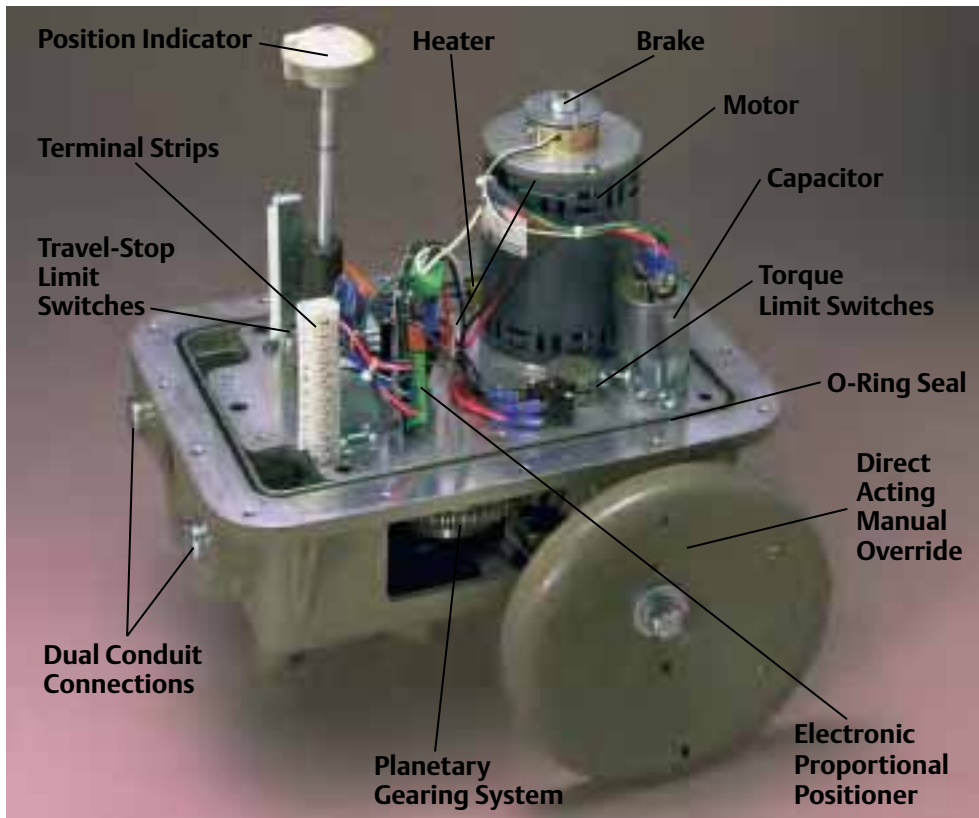

MODEL EM-800 SERIES						
TORQUE		SPEED 90°	MODEL	LOCKED ROTOR AMP		MOTOR DUTY CYCLE @ 75°F
IN/LB	NM			115VAC	230VAC	
2000	226	12 SEC	810-12	3.15	1.3	100%
2500	282	18 SEC	810-18	3.15	1.3	100%
3500	395	30 SEC	810-30	3.15	1.3	100%
4000	452	60 SEC	810-60	3.15	1.3	100%
3000	338	12 SEC	820-12	3.15	1.3	100%
4000	452	18 SEC	820-18	3.15	1.3	100%
6000	678	30 SEC	820-30	3.15	1.3	100%
7000	791	60 SEC	820-60	3.15	1.3	100%
5000	565	12 SEC	830-12	5.97	2.81	100%
7000	791	18 SEC	830-18	5.97	2.81	100%
10000	1130	30 SEC	830-30	5.97	2.81	100%
10000	1130	60 SEC	830-60	5.97	2.81	100%
15000	1695	48 SEC	840-48	5.97	2.81	100%
20000	2260	72 SEC	840-72	5.97	2.81	100%

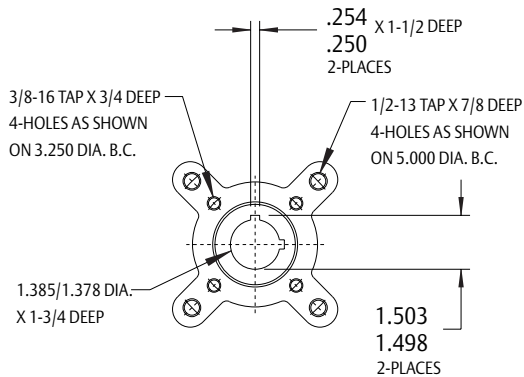
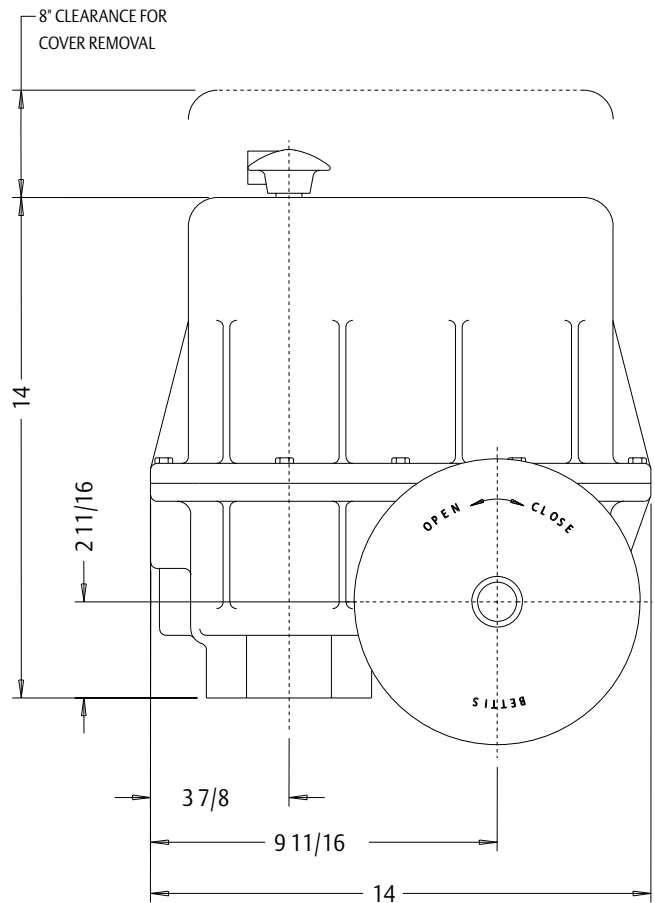
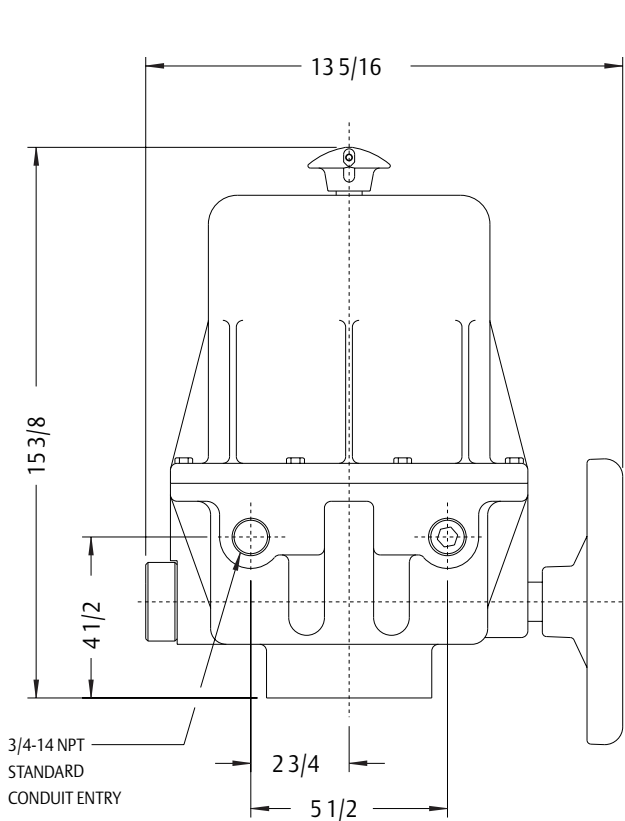

**Bettis Electric**

2500 Park Avenue West, Mansfield, OH 44906 U.S.A. T 419-529-4296 F 419-529-4484  
Website: [www.EmersonProcess.com/Bettis](http://www.EmersonProcess.com/Bettis) E-Mail: [Info.Bettis.Electric@EmersonProcess.com](mailto:Info.Bettis.Electric@EmersonProcess.com)

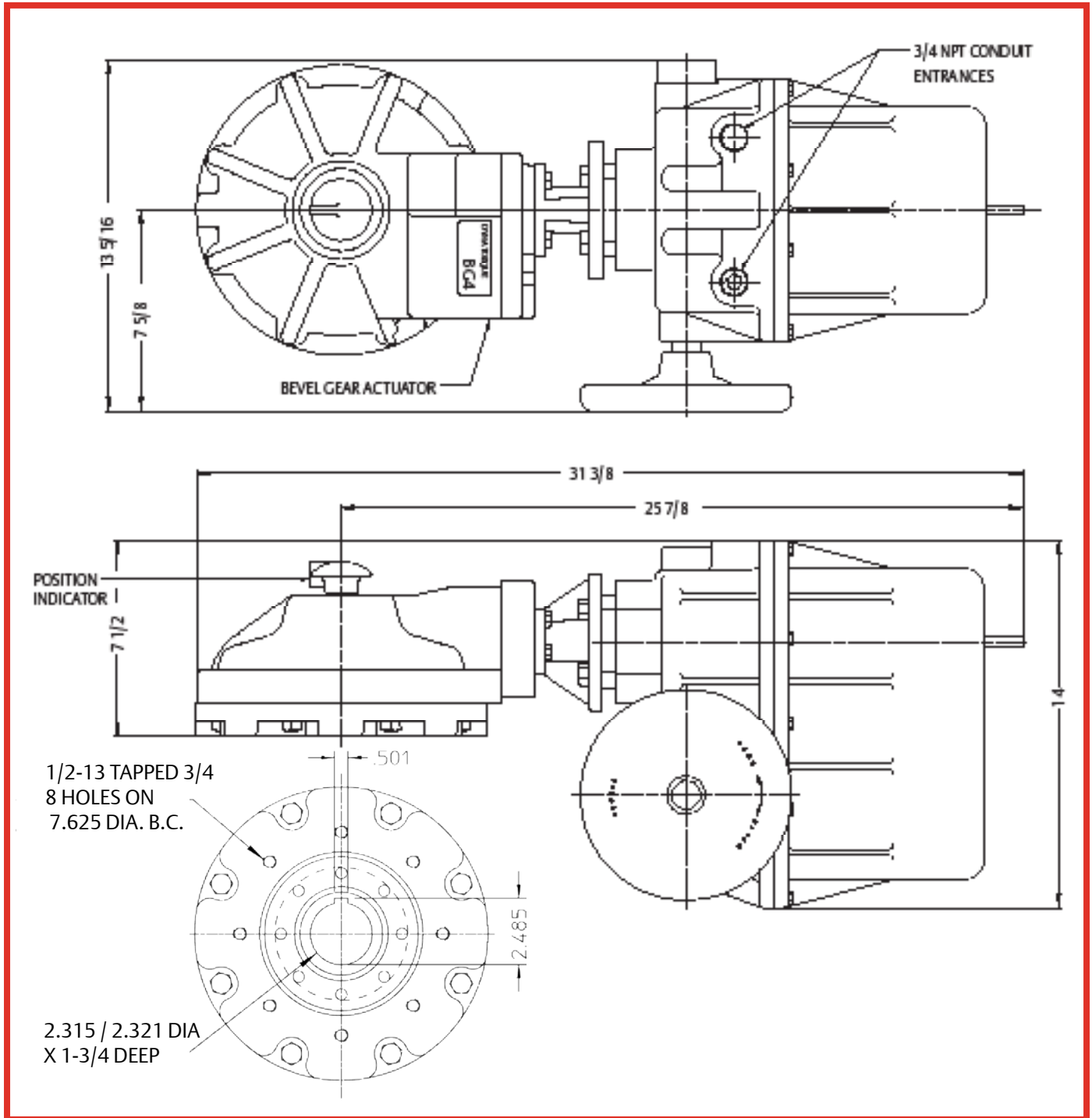

**Bettis Electric**

2500 Park Avenue West  
Mansfield, OH 44906 U.S.A.  
T 419-529-4296  
F 419-529-4484

Website: [www.EmersonProcess.com/Bettis](http://www.EmersonProcess.com/Bettis)  
E-Mail: [Info.Bettis.Electric@EmersonProcess.com](mailto:Info.Bettis.Electric@EmersonProcess.com)

**Bettis USA**

P.O. Box 508  
Waller, TX 77484 U.S.A.  
T 281-463-5100  
F 281-463-5103

Website: [www.EmersonProcess.com/Bettis](http://www.EmersonProcess.com/Bettis)  
E-mail: [Info.Bettis@EmersonProcess.com](mailto:Info.Bettis@EmersonProcess.com)

**Bettis UK Ltd.**

3 Furze Court  
114 Wickham Rd.  
Fareham, Hampshire PO 16 7SH  
T 44-1329-848-900  
F 44-1329-848-901

**Bettis France:**

25, Rue de Villeneuve  
Silic – BP 40434  
94583 Rungis, France  
T 331-49-797300  
F 331-49-797399

**Bettis Int'l Sales Office:**

Willich, Germany  
Mumbai, India  
Singapore

**Important:** Due to Emerson's continuing commitment to engineered product advancement, data presented herein is subject to change.

Certified dimensional drawings and wiring diagrams are available on request. Consult factory with model designation and serial number.

Bettis Bulletin # 10.10 Rev: 07/12

© 2002 Emerson. All rights reserved. 5M/07/12

**BETTIS™**

**EMERSON™**  
Process Management