

BETTIS™

TorqPlus™
Electric Valve
Actuators
and Controls



EMERSON™
Process Management

EMERSON. CONSIDER IT SOLVED.™



Torque 300 IN/LB – 1,600 IN/LB

The Engineered Solution

Bettis TorqPlus has taken the lead in offering compact, cost effective Spring Return Electric Actuator Packages. Three models offer a variety of solutions when one needs to protect a system upon loss of power. These actuators have been designed for dampers, small butterfly, ball and plug valves.



The Model EM-SR5 Series is designed for use in environments where automatic closing/opening is required upon loss of power, with a rugged versatility that is hard to beat.

When power is available, the device operates like a normal quarter turn, open/close or modulating actuator. Under powered operation, the spring pack travels with the movement of the actuator. Under powered stopped conditions, the actuator and spring are held in position via the electric mechanical brake. Upon loss of power, the spring is released and drives the actuator to the predesignated failsafe position. The failsafe positioning can be provided for either the CCW limit or to the CW limit.

STANDARD FEATURES

- Two year warranty
- Heater and thermostat
- Case hardened steel spur gear train is permanently lubricated
- Operating temperatures: -40° F, with standard heater activated, to +140° F
- Thermally protected permanent split capacitor motor
- Electromechanical brake
- CW or CCW spring return
- Dual 1/2-inch NPT conduit entrances
- Captive hex bolts on enclosure
- Operational in any mounting orientation
- Limit switches with independent end of travel cams
- Male output drive on all models or female DIN/ISO F04 or F05 output drive on 10, 15 and 30 second models
- Adjustable mechanical stop at the fail safe position
- Visual position indicator
- Enclosure certified to weatherproof C.S.A. specifications that conform to NEMA type 1, 2, 3, 3R, 4, 4X and 12

OPTIONAL FEATURES

- Modulating service (separate enclosure)
- Standard 1KΩ potentiometer, other ranges provided upon request
- Optional 220 VAC 50/60 Hz motor
- Up to four auxiliary switches with adjustable cams
- Canadian Standard Association general purpose for electrical certification available under file #LR90062
- Dual purpose weatherproof and explosion-proof enclosures are certified by Canadian Standards Association for services: Class I Groups C,D, Division I; Class II Groups E,F,G Division I that conform to NEMA type 7 and 9

MODEL EM-SR5 SERIES										
Model	Torque (against spring)		Torque (with spring)		Speed (sec/90°)		Motor Ratings			Weight (lbs)
	in/lb	nm	in/lb	nm	Motor	Spring	LRA	FLA	Duty Cycle	
SR5-10	300	34	350	40	10	4	0.69	0.34	100%	28-30
SR5-15	400	45	450	51	15	5	0.69	0.34	100%	28-30
SR5-30	600	68	700	79	30	6	0.35	0.30	100%	36-38
SR5-90	1600	181	1400	158	90	25	0.35	0.30	100%	138



Torque 300 IN/LB – 1,400 IN/LB

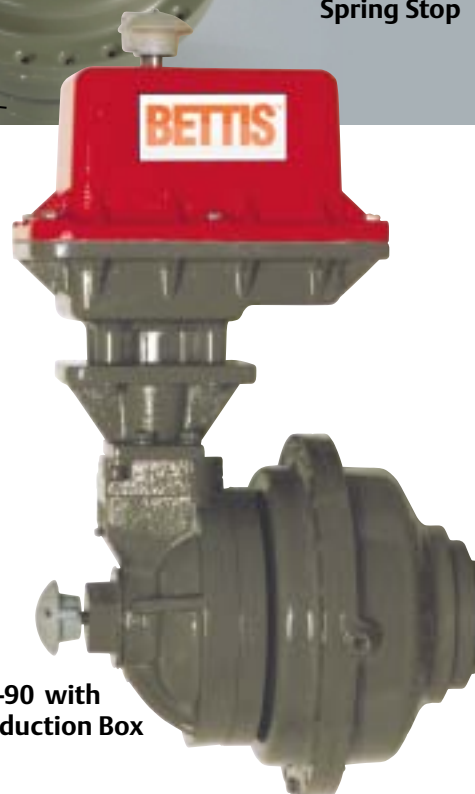
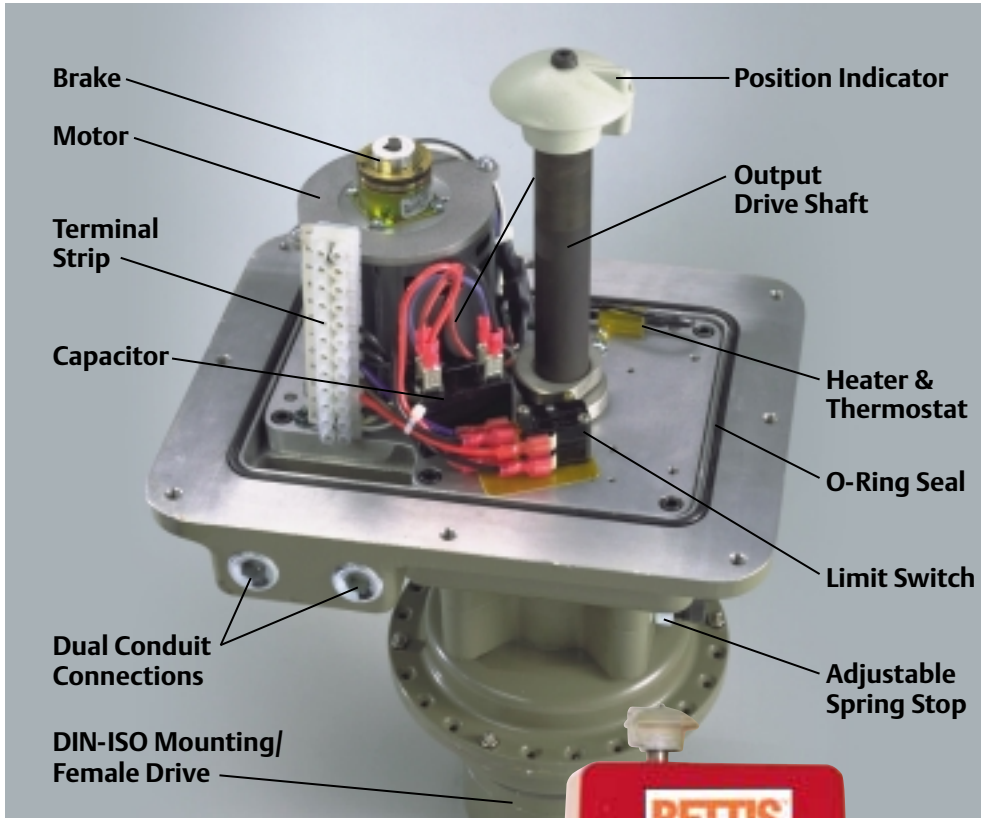

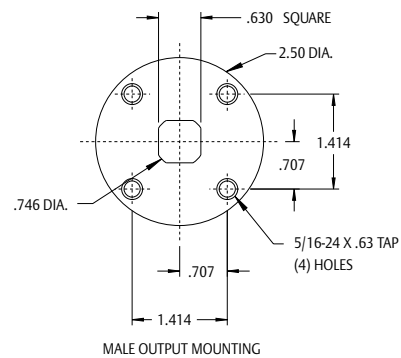
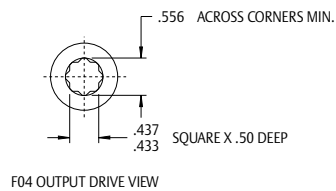
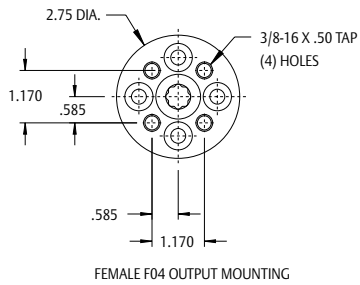
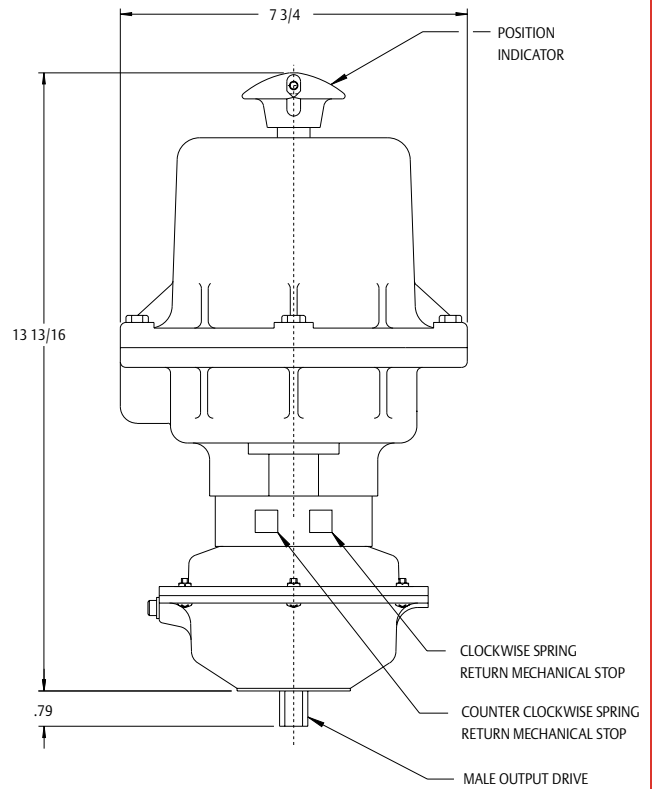
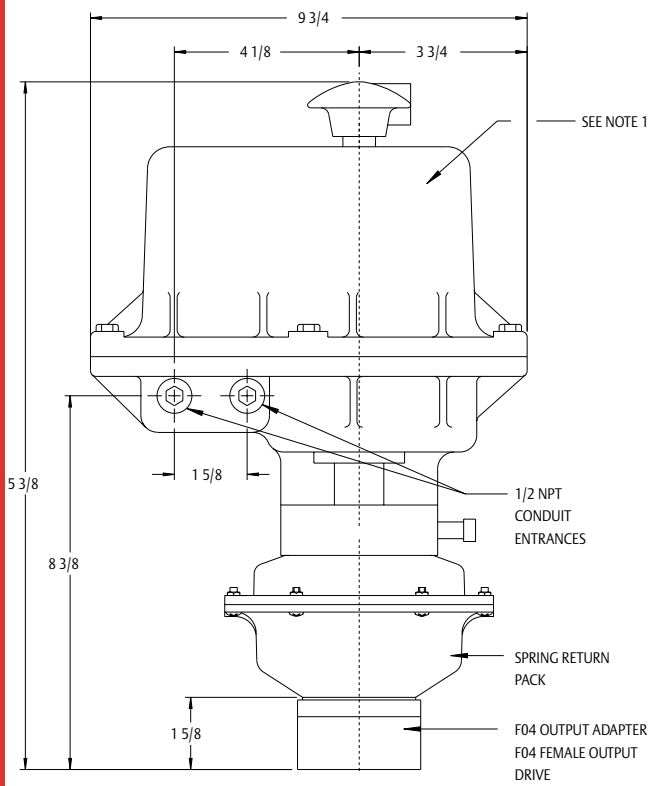

NOTE:
1) ADD 4.75 TO OVERALL DIMENSION FOR COVER REMOVAL

Bettis Electric

2500 Park Avenue West, Mansfield, OH 44906 U.S.A. T419-529-4296 F419-529-4484
Website: www.EmersonProcess.com EMail: Info.Bettis@EmersonProcess.com

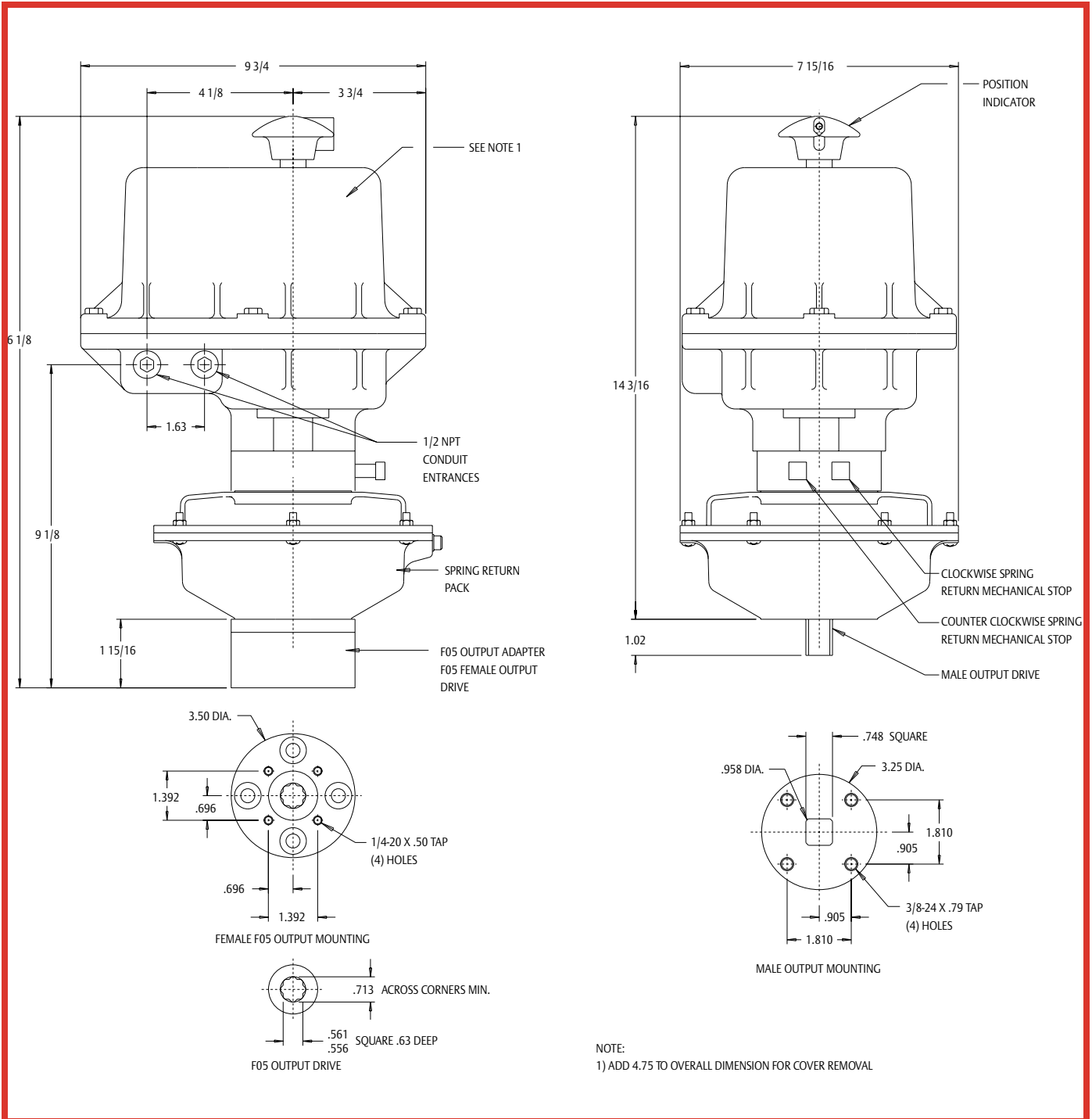

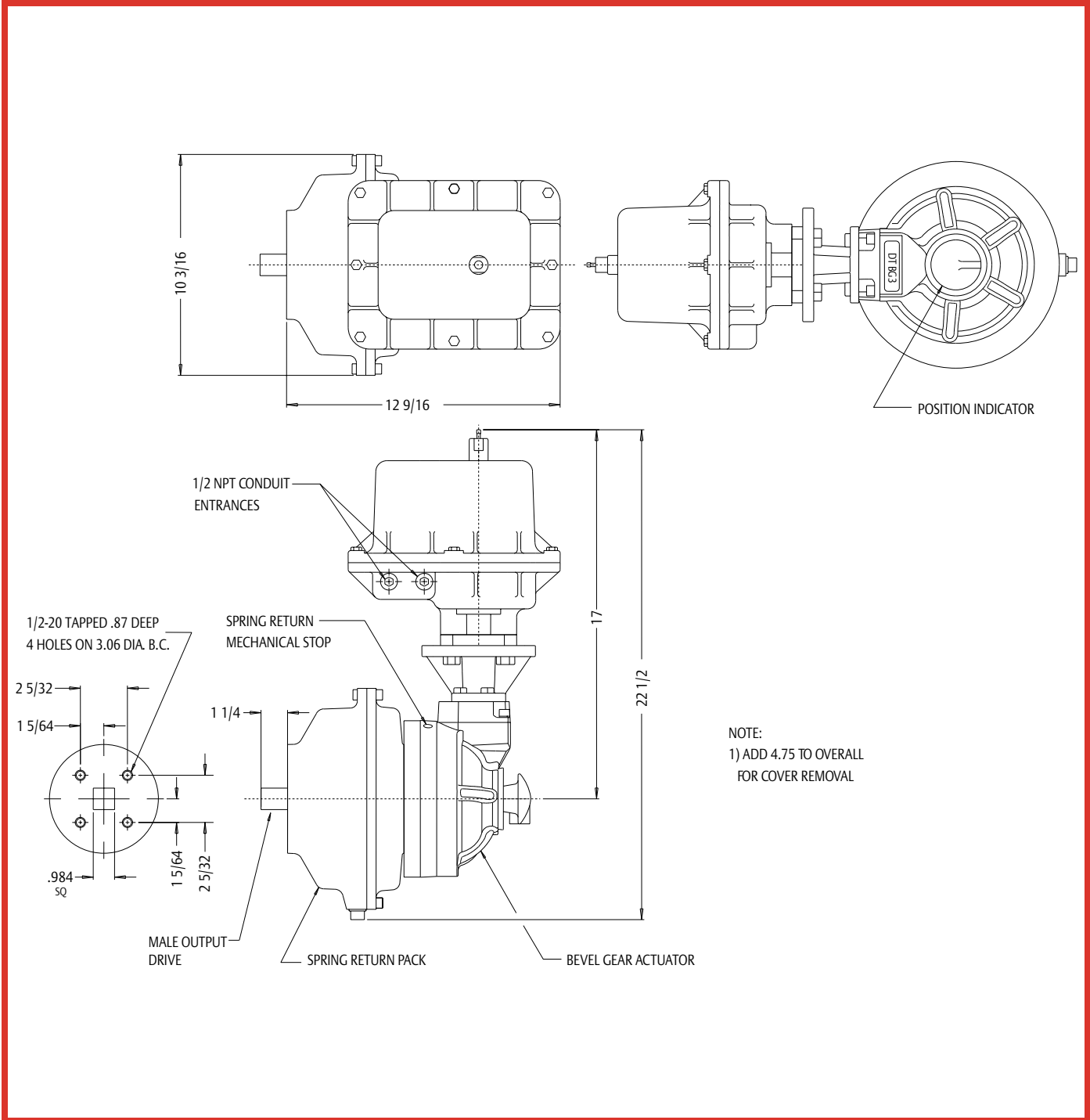

Bettis Electric
 2500 Park Avenue West, Mansfield, OH 44906 U.S.A. T419-529-4296 F419-529-4484
 Website: www.EmersonProcess.com EMail: Info.Bettis@EmersonProcess.com

Bettis Electric

2500 Park Avenue West
Mansfield, OH 44906 U.S.A.
T 419-529-4296
F 419-529-4484
Website: www.EmersonProcess.com
E-Mail: Info.Bettis@EmersonProcess.com

Bettis USA

P.O. Box 508
Waller, TX 77484 U.S.A.
T 281-463-5100
F 281-463-5103
Website: www.EmersonProcess.com
E-mail: Info.Bettis@EmersonProcess.com

Bettis UK Ltd.

3 Furze Court
114 Wickham Rd.
Fareham, Hampshire PO 16 7SH
T 44-1329-848-900
F 44-1329-848-901

Bettis Canada Ltd.

4112-91 A Street
Edmonton, Alberta T6E 5V2
Canada
T 780-450-3600
F 780-450-1400

Bettis France:

325, Rue de Villeneuve
Silic – BP 40434
94583 RUNGIS, France
T 331-49-797300
F 331-49-797399

Bettis Int'l Sales Office:**Calgary, Canada**

Rheinberg, Germany
New Bombay, India
Singapore

Important: Due to Emerson's continuing commitment to engineered product advancement, data presented herein is subject to change.

Certified dimensional drawings and wiring diagrams are available on request. Consult factory with model designation and serial number.

Bettis Bulletin # 10.10 Rev: 02/02

© 2002 Emerson. All rights reserved. 5M/02/02

BETTIS™

EMERSON™
Process Management