

# Direct Gas-Fired Make-Up Air Models DG, DGX, TSU and VSU

Industrial, Manufacturing, Warehouse and Kitchen Applications



BUILDING VALUE IN AIR.



May  
2024

## Setting the Industry Standard for Make-Up Air

### Model DGX

- 800 – 48,000 cfm and up to 5 in. wg
- Flexible modular construction for increased design flexibility
- Optional variable air volume (VAV) arrangement with up to 50% airflow reduction
- Optional recirculation arrangement for 20 – 100% outside air
- Optional direct drive mixed flow or backward-curved plenum fans

#### Heating

- Direct gas-fired heating technology with 92% thermal efficiency
- Up to 4800 mbh
- Up to 30:1 turndown ratio

#### Cooling

- Chilled water or split direct expansion coils up to 11,700 cfm
- Direct evaporative cooling up to 46,250 cfm
- Packaged direct expansion cooling up to 16 tons and 8,100 cfm
- Low sound condenser fans
- Optional digital or standard scroll compressor
- Optional electronically commutated (EC) motor on lead condenser fan

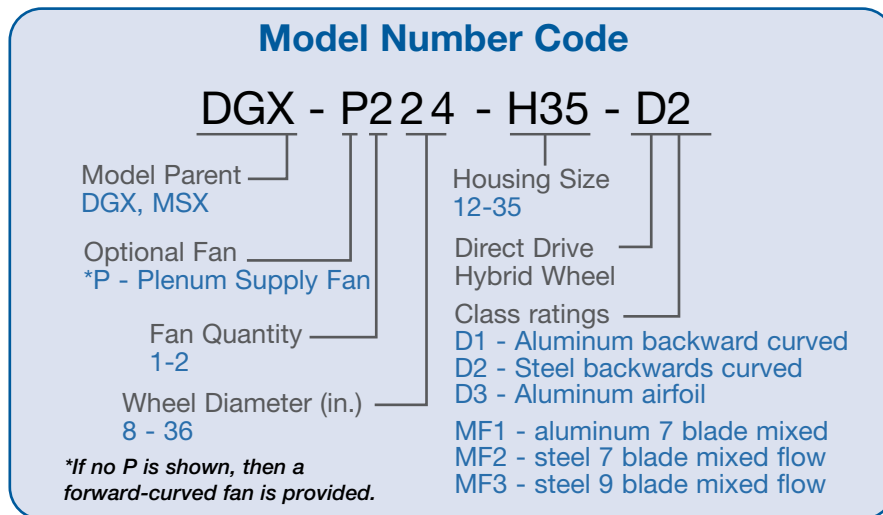

### Model DG

- 800 to 6,900 cfm and up to 3 in. wg
- Cost-effective unitary housing construction for budget-sensitive applications that require both heating and cooling
- Optional variable air volume (VAV) arrangement with up to 50% airflow reduction

#### Heating

- Direct gas-fired heating technology with 92% thermal efficiency
- Up to 800 mbh
- Up to 30:1 turndown ratio



## Setting the Industry Standard for Make-Up Air

### Model TSU

- 33,000 – 64,000 cfm and up to 2.5 in. wg
- Dual blower design for high air volumes
- Optional variable air volume (VAV) arrangement with up to 50% airflow reduction
- Optional recirculation arrangement for 20 – 100% outside air

#### Heating

- Direct gas-fired heating technology with 92% thermal efficiency
- Up to 7000 mbh
- Up to 30:1 turndown ratio

#### Cooling

- Direct evaporative cooling up to 60,000 cfm



### Model VSU

- 800 – 64,000 cfm and up to 2.5 in. wg
- Vertical design for outdoor pad-mounted applications
- Optional variable air volume (VAV) arrangement with up to 50% airflow reduction
- Optional recirculation arrangement for 20 – 100% outside air

#### Heating

- Direct gas-fired heating technology with 92% thermal efficiency
- Up to 7000 mbh
- Up to 30:1 turndown ratio

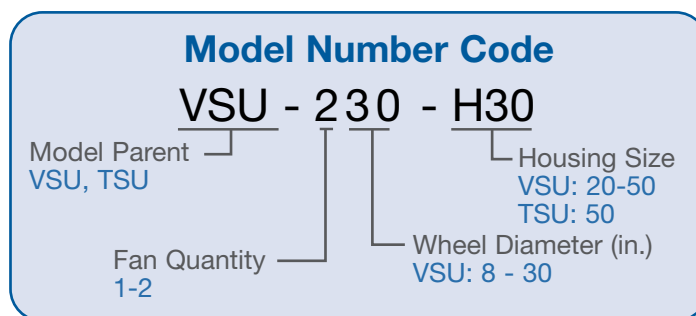

### Product Certifications

Greenheck takes pride in offering a high quality, reliable product. We invest our resources into designing, testing and manufacturing products to ensure customer satisfaction.



ETL Listed for electrical and overall unit safety. Every unit is tested at the factory before it is shipped to the jobsite.

## ***Innovative Fan Technologies from the Industry Leader***

### **Direct Drive Mixed Flow Plenum Fans**

Mixed flow fans are hybrid designs that incorporate the best features of axial and centrifugal fans. The unique mixed flow plenum fan is optimized for typical make-up air applications below 3.0 in. wg:

- Optional on Models DGX, IGX and MSX from 800 – 25,000 cfm
- Industry-leading operating power requirements, with up to 50% reduction in comparison to a traditional belt-driven forward-curved fan
- Reduced sound levels
- Non-overloading fan performance curve
- Direct drive with factory VFD for pushbutton balancing

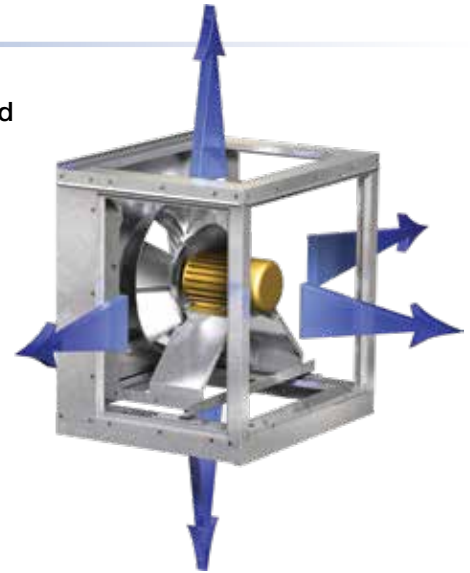

### **Direct Drive Backward-Curved Plenum Fan**

Backward-curved plenum fans provide enhanced airflow performance at high static pressures. Optimized for applications up to 5 in. wg, these fans are ideal options for applications with high filtration requirements or long tight duct runs.

- Optional on Model DGX from 800 – 45,000 cfm
- Non-overloading fan performance curve
- Direct drive with factory variable frequency drive (VFD) for pushbutton balancing

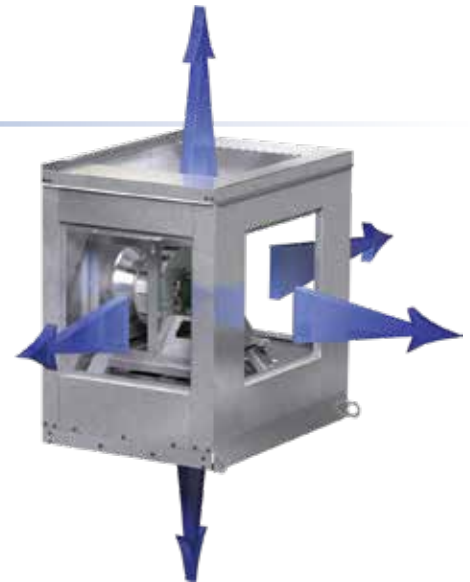

### **Hybrid-Centrifugal Plenum Fan**

Hybrid centrifugal plenum fans are single width, single inlet fans. The impellers are unshrouded, with blades that curve away from the direction of rotation. These fans throw the air radially outward, approximately 90 degrees from the inlet direction, pressurizing the fan cabinet. These fans are direct driven with the impeller mounted directly to the motor shaft. A "P" and "D1 or D3" are present in the model number.



## Configurability for Countless Applications

### Variable Air Volume (VAV)

VAV is a challenge in direct gas-fired equipment because airflow through the direct-gas burner must remain constant as airflow varies to ensure complete combustion. Greenheck's patented VAV design provides industry-leading airflow reduction while minimizing cost and maintenance. The VAV configuration is ideal for minimizing energy consumption in many applications, from responding to varying cooking loads in kitchens to maintaining building pressurization in large manufacturing facilities and anywhere in between.

- Up to 50% airflow reduction
- The patented barometric bypass damper VAV design is self-adjusting with minimal maintenance and no special controls are required
- Optional factory-installed variable frequency drive (VFD) or wiring provisions for remote mounted VFD



### Recirculation Arrangement

The recirculation arrangement allows for varying outside air from 20 – 100%. This configuration is ideal for heating and ventilating in large manufacturing, warehouse or industrial facilities and is commonly used to maintain positive building pressurization.

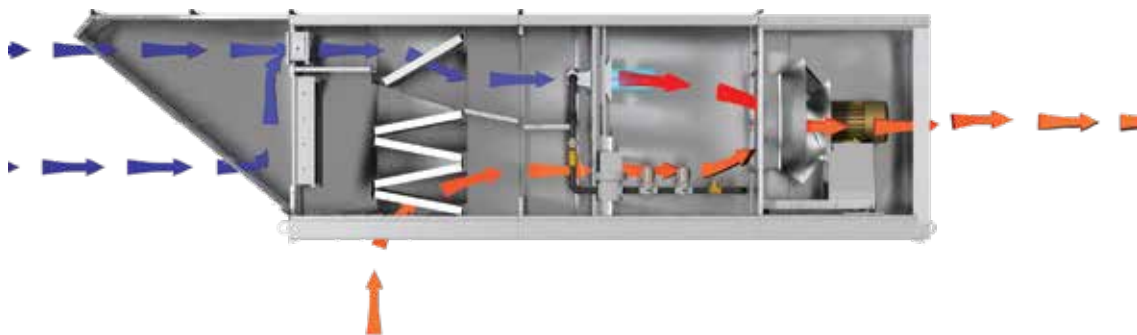

### Flexible Discharge Arrangements

A variety of configurable discharge positions are available for installation flexibility. The plenum fans available on model DGX take this to the next level allowing left or right side discharge ideal for indoor applications or tight roof installations by potentially eliminating an elbow in the duct run.

## Controls Made Simple

### Microprocessor

Models DGX, TSU and VSU are available with an optional microprocessor controller that is factory programmed, wired and tested prior to shipment. The controller is the ideal solution for integrating with a building management system (BMS) but also can operate completely stand-alone.

- All controllers are provided with a built-in backlit LCD and keypad to provide easy access to status, set points and settings
- Optional plug-and-play remote display
- Optional BMS communication BACnet® MS/TP, BACnet® IP, LonWorks®, or Modbus® RTU
- Optional sensors are available for room temperature control, building pressure fan or outdoor air damper control, CO2 fan or damper control, or duct pressure fan control



### Pre-Configured and Field Adjustable

All microprocessor controls have a factory-programmed configuration code that configures the controller to match the order. If for any reason this needs to be changed the code can be updated in the field for any configuration in minutes with just the built-in LCD and keypad – No computer programming required!

### Remote Panel

For applications that don't require building management system integration, an optional remote panel is a simple cost-effective way to control a make-up air unit. Remote panels are available with a variety of options to meet the needs of the application.

- Painted NEMA 1 enclosure or stainless steel NEMA 4X enclosure
- Basic switches to enable the fan, heating and cooling
- Indicating lights for basic unit status
- Discharge temperature dial, room thermostat, or room sensors
- Programmable thermostat for night setback operation
- Outdoor air damper or VAV control with a Photohelic® for building pressure control, potentiometer dial or switch.



## Cooling Make-up Air Sensibly

### Packaged Direct Expansion (DX) Cooling

Cooling 100% outside air can be challenging and expensive due to varying outside air conditions. Greenheck make-up air approaches this challenge sensibly with a cost-effective packaged DX system designed to cool outside air to 65-75°F. By only cooling to these temperatures, cooling capacity can be reduced by 50-65% in comparison to fully dehumidifying dedicated outdoor air equipment significantly. This not only reduces first cost, but also operation costs, and therefore provides improved occupant comfort in applications such as kitchens, auto shops, and small manufacturing areas at an affordable price.

#### Model DGX

- 800 – 8,100 cfm
- 2.5 – 16 tons
- Optional standard scroll or digital scroll compressor
- Lead EC condenser fan with digital scroll compressor



Features	Benefits
Side mounted condensing section	Minimizes equipment height to avoid site line to equipment on the roof
Draw through coil design	Maximizes utilization of the coil for improved efficiency, and a wider operating temperature range
Low sound condensing fans	Significantly reduces sound levels by up to 8 decibels
Isolated service access	Easy access to all refrigeration components that can be accessed without affecting airflow
Engineered cooling system	Designed and tested by Greenheck engineers specifically for make-up air applications, ensuring optimal performance and a wider operating temperature range

**S** Standard Feature    **O** Optional Feature

## 1 Construction

- Constructed of heavy-gauge G90 galvanized steel
- Single or double-wall construction with 1-inch fiberglass insulation
- Removable access panels with optional hinged doors
- Available finishes include:
  - Permator™ (2,500 hr/salt spray rating under ASTM B117 testing conditions)
  - Hi-Pro Polyester (5,000 hr/salt spray rating under ASTM B117 testing conditions)

## 2 Weatherhood

- Weatherhood with birdscreen features a wire mesh intake, preventing large debris from damaging the filters. An additional filter section is required
- Aluminum mesh filtered weatherhood eliminates the need for an additional filter section
- Louvered weatherhood includes a drainable blade louver at intake with 2-inch aluminum mesh filters
- The thru-wall sleeve provides an attachment interface between the weatherhood and burner section. The sleeve accommodates walls up to 15 inches (38 cm) in depth

## 3 Filter Section

- V-bank filter section or mixing box
- 2-inch washable aluminum mesh
- 2-inch MERV 8 pleated disposable
- 2-inch MERV 13 pleated disposable
- 4-inch MERV 14 pleated disposable
- 2-inch MERV 8 and 2-inch MERV 13 pleated disposable
- 2-inch MERV 8 and 4-inch MERV 14 pleated disposable

## 4 Dampers

- Low-leakage non-insulated inlet damper with factory-mounted and wired actuators
- Low-leakage non-insulated outlet damper  
Factory-mounted and wired damper and actuators

## 5 Direct Gas-Fired System

- High-quality cast aluminum burners with stainless steel mixing plates
- Up to 30:1 turndown ratio
- Electronic modulation burner control
- Flame safeguard with optional digital fault indicator
- FM Global gas train configurations available
- High/low gas pressure switches automatically shuts down the burner if the manifold pressure/inlet gas pressure is too high/low for the burner to operate properly

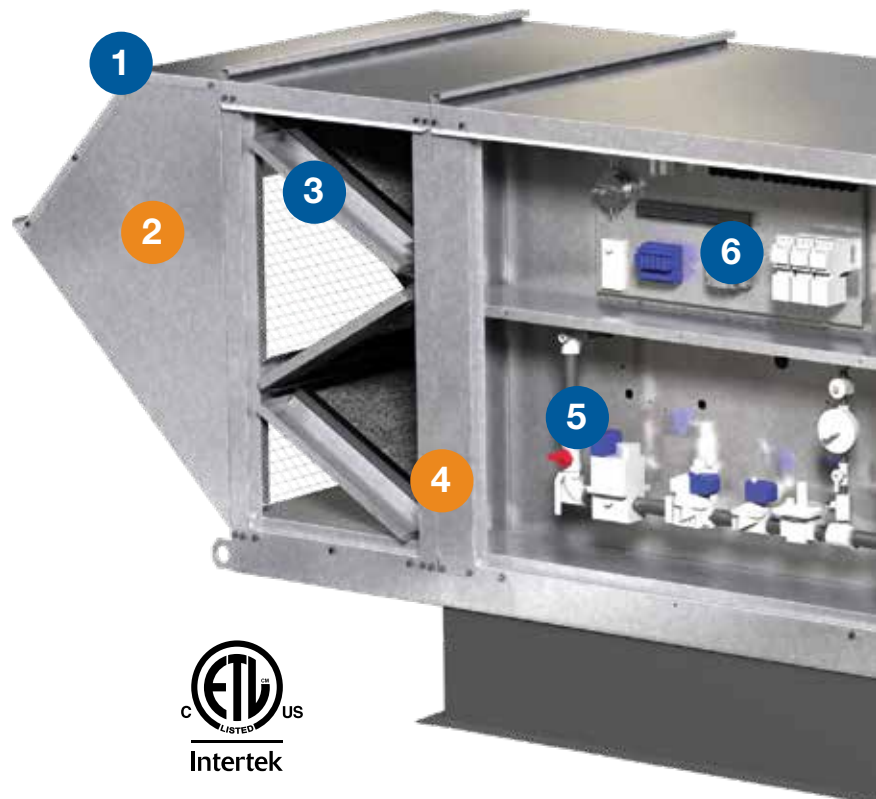

## 6 Control Center

- 24-volt control voltage
- Magnetic motor starter with solid-state overload protection
- Control transformer
- Disconnect switch
- Distribution terminal strip
- Factory prewired for single point power connection



**7**

### Cooling Options

All cooling options include a stainless steel drain pan

- Evaporative cooler
- Chilled water coils
- Split DX coil (coils only)
- Packaged direct expansion (PDX)  
*Includes condensing fans and coils.*

**8**

### Supply Fan Options

- Belt-driven, forward-curved fan with optional factory-provided VFD
- Direct drive, backward-curved plenum fan with factory-provided VFD (shown)
- Direct drive, mixed flow plenum fan with factory-provided VFD

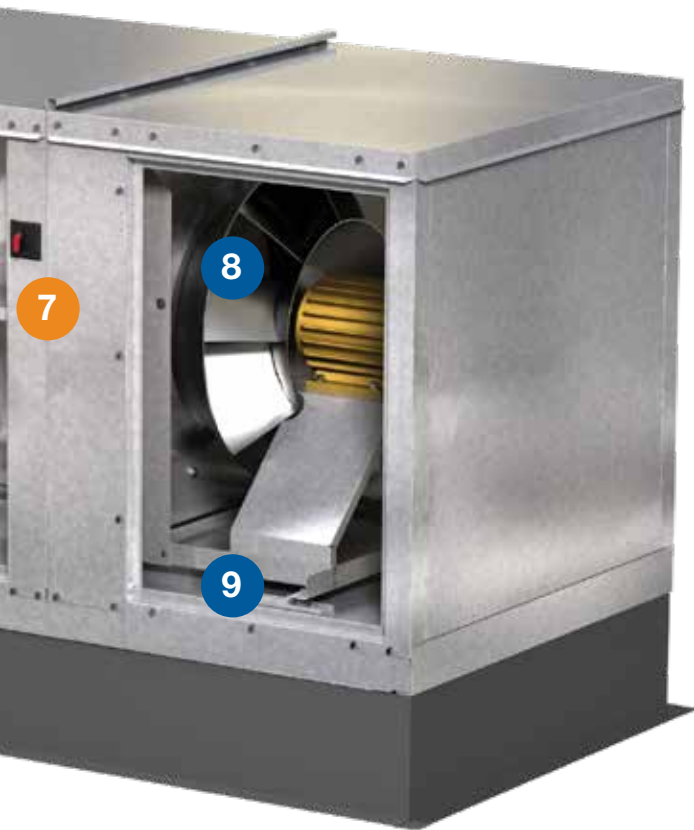
**9**

### Vibration Isolators

- The entire fan and motor assembly is mounted on vibration isolators to minimize noise transmission into the building. Neoprene or spring isolators are available on forward-curved supply fan models. Backward-curved and mixed flow supply fan models only offer neoprene isolators.

## Optional Electrical Controls

**Auxiliary Contacts** – Normally open and normally closed contacts are available for supply fan status and supply fan interlocks.

**Cooling Relay** – When interlocked with a rooftop unit (RTU), this relay can be used to lockout a call for heat from the make-up air unit when there is a simultaneous call for cooling from the RTU.

**CO<sub>2</sub> Sensor** – Shipped loose for field mounting and wiring in the supply or return air duct.

**Dirty Filter Sensor** – Monitors the pressure drop across the filter section. If the pressure drop is higher than the field-adjustable setting, the switch will trip and indicate that the filters need to be cleaned or replaced. An indicator light may be wall/beam mounted or provided with a remote panel.

**Exhaust Fan Starter(s)** – Factory-mounted and wired for an electrical interlock between the supply and exhaust fan(s).

**Fire Stat Type III** – Shipped loose for field mounting and wiring in the supply or return air duct. Contains two normally open and two normally closed contacts for alarm notification.

**Flame Safeguard Display** – Interfaces with the flame safeguard. It displays a detailed history of the faults that have occurred as well as the current status of the MUA unit. The display is detachable and can be used on multiple units. MUA must have a pilot ignition for this option to be valid.

**Freeze Protection** – Automatically shuts down the supply fan when the discharge temperature is below the set point for an extended amount of time. This prevents the unit from discharging non-tempered air into the building and freezing pipes and other temperature-sensitive items.

**Heating Inlet Air Sensor** – Automatically turns the heat on and off based on a field-adjustable set point.

**Inlet Damper End Switch** – Will not allow the starter to engage until end switch is proved, ensuring that the inlet damper is fully open before unit operation.

**Service Receptacle** – A 115-volt GFCI outlet can be shipped loose or factory-mounted and wired in a NEMA-3R box for the convenience of service personnel.

Model	DGX-H05	DGX-H12	DGX-H22	DGX-H32	DGX-H35	DGX-H38	DGX-H42	
Unit	Airflow Range (CFM)	800-2,200	800-3,200	2,600-7,500	4,500-16,000	10,000-25,000	20,000-33,000	28,000-48,000
	Approximate Weight* (lbs)	450**	700	1,100	1,500	2,300	3,000	4,000
	Height (in.)	26	39	44.9	48.7	54.6	63.9	67.9
	Width (in.)	24	33.7	44.1	53.1	78.5	95.5	100.3
	Overall Width with Evaporative Cooling (in.)	24	33.7	>4,800 cfm = 60.6	≤9,000 cfm = 66.5 >9,000 cfm = 96.5	120.5	95.5	100.3
<b>Lengths (in.)</b>								
Module 1	Birdscreen Weatherhood	-	29.9	45.6	47.3	47.1	60.9	70.0
	Aluminum Mesh Filtered Weatherhood	25	31.5	47.1	48.7	47.8	65.3	68.9
	Louvered Weatherhood	-	13.8	16.9	16.9	-	-	-
	Thru-Wall	-	69.9	82.3	104.7	120.6	-	-
	Evaporative Cooling	30.6	30.2	30.2	≤9,000 cfm = 34.7 >9,000 cfm = 38.1	38.1	98.5	116.5
Module 2	V-Bank Filter Section	7	21.5	24.1	25.8	27.7	30.8	31.1
	80/20 Filter Section	-	-	44.1	50.2	51.3	50	55
Module 3	Cooling Coil (standard)	-	30	30	-	-	-	-
	Cooling Coil (high capacity)	-	50.4	69.4	98.1	-	-	-
Module 4	Burner	32.3	37.6	52.3	52.5	54.9	58.1	58.1
Module 5	Forward-Curved Fan	-	42.5	52.2	65.9	62	71.5	75.5
	Backward-Curved Fan	26	25.1	32.2	51.1	84.6	92.1	101.1
	Mixed Flow Plenum	-	26.1	36.1	44	84.7	-	-

\*Weight based on DGX with optional birdscreen weatherhood, V-bank filter section and forward-curved downblast fan discharge.

\*\*Weight for model DGX-H05 included aluminum mesh weatherhood, V-bank filter section and backward-curved fan.

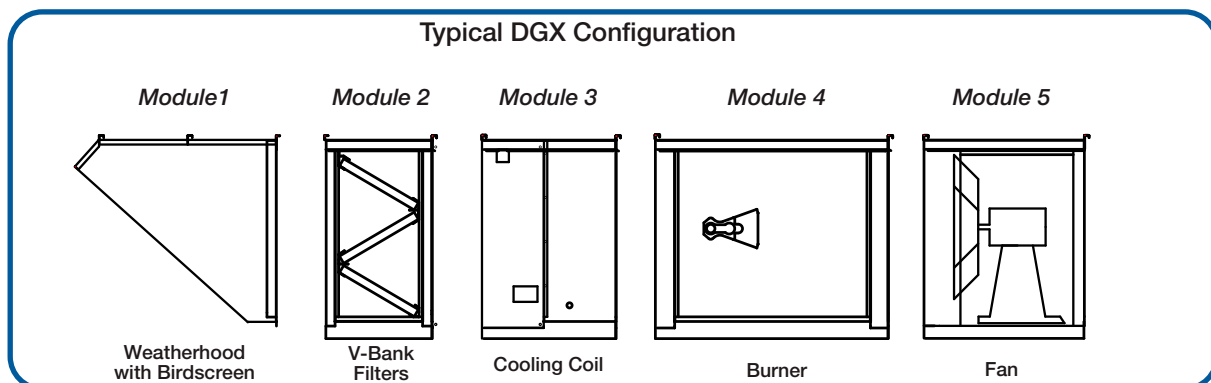

## Model VSU

### Housing Sizes 20 & 30

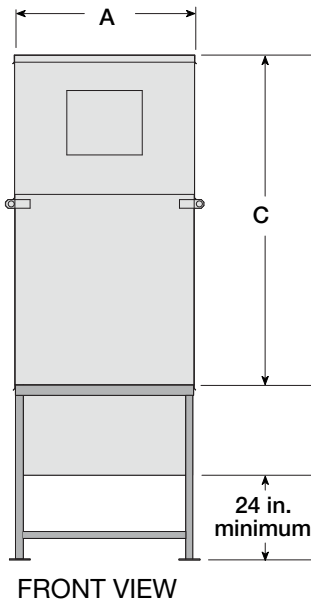

### Housing Sizes 40 & 50

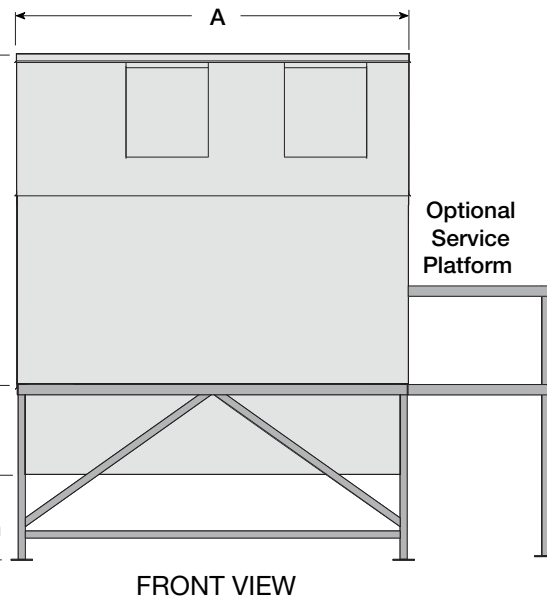

### Housing Sizes 20 thru 50

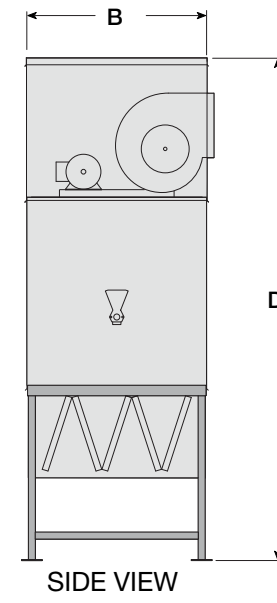

Model	A	B	C	D	Approx. Weight (lbs.)*	Airflow Range (CFM)
VSU-20	40	40	78	128	1,200	2,500 - 6,500
VSU-30	52	53	92	146	1,700	6,000 - 12,000
VSU-40	111	54	95	144	3,750	14,000 - 28,000
VSU-50	156	63	107	184	5,500	32,000 - 60,000

All dimensions are shown in inches.

\*All weights are shown in pounds and include 2-inch aluminum mesh filters.

## Optional Service Platform

The minimum distance from the ground to the filter intake is 24 inches. For housing size 50, the minimum distance is 48 inches. This is intended to minimize debris and moisture from being entrained in the make-up air. In locations where heavy snowfall is common, this dimension may need to be greater. Specify the minimum clearance dimension when ordering.

Housing Size	20, 30, 40			50			
	Stand	24 in.	48 in.	60 in.	24 in.	48 in.	60 in.
E		60.75	84.75	96.75	60.75	84.75	96.75
F		44	44	44	57.5	57.5	57.5
G		42.25	42.25	42.25	42.25	42.25	42.25
H		42	42	42	42	42	42

All dimensions are shown in inches.

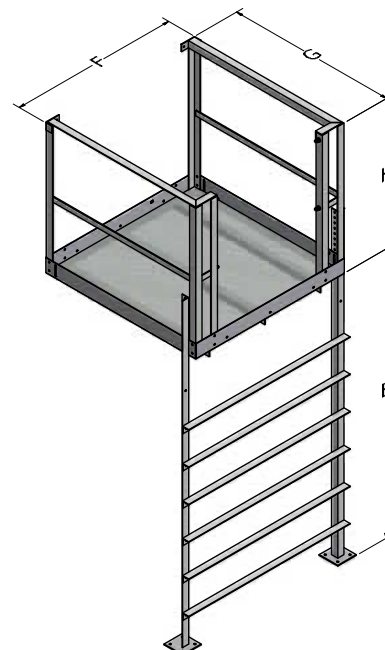

# TSU and DG Dimensional Data

## Model TSU

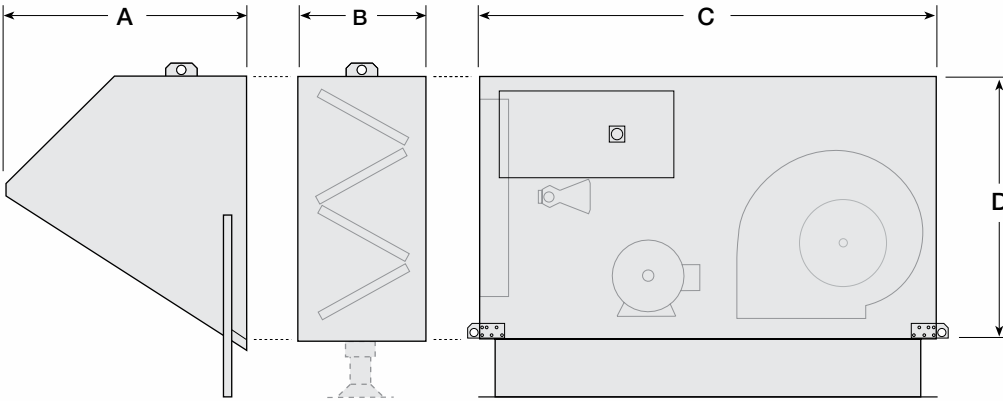

Model	A	B	C	D	Approx. Weight (lbs.)*	Airflow Range (CFM)
TSU-50	71	31	100	64	see CAPS®	32,000 - 60,000

All dimensions are shown in inches.

\*All weights are shown in pounds and include 2-inch aluminum mesh filters.

## Our Commitment

*As a result of our commitment to continuous improvement, Greenheck reserves the right to change specifications without notice.*

Specific Greenheck product warranties are located on [greenheck.com](http://greenheck.com) within the product area tabs and in the Library under Warranties.

Greenheck P.O. Box 410 • Schofield, WI 54476-0410 • Phone (715) 359-6171 • [greenheck.com](http://greenheck.com)

Copyright © 2024 Greenheck Fan Corp. • 00.TAP.1046 R3 5-2024 FS

