

# Energy Recovery with Cooling and Heating Model ERCH

- 100% Outdoor Air System • Dedicated Outdoor Air System

- 1,000 - 10,000 cfm
- 1.75 in. wg External Static Pressure
- Indirect Gas, Hot Water, Electric Heating, Water-Source Heat Pump
- Chilled Water, Split DX Cooling, Evaporative Cooling, Water-Source Heat Pump



## Product Overview

Greenheck's model ERCH combines the benefits of the total energy wheel with supplemental cooling and/or heating. The result is a product that is specifically designed to condition 100% outdoor air to desired supply conditions.

Model ERCH offers a wide variety of configurable options from intake and discharge orientations to factory tested and proven control sequences. This model is ideal for many different 100% outdoor air system applications.

## Model ERCH Features

- Up to 10,000 cfm and 1.75 in. wg external static pressure
  - Double-wall construction
  - Blower vibration isolation
  - G90 galvanized exterior with paint options
  - Filter Options
    - MERV 8
    - MERV 13
    - Combination MERV 8 and 13
  - Controls Options
    - Stand-alone microprocessor
    - Network interface
    - Optional fan control by microprocessor
    - Additional monitoring points
  - Downturn or louvered weatherhood
    - Aluminum mesh filters
- Cooling Options
    - Split system DX coil
    - Chilled water coil
    - Water-source heat pump
    - Evaporative cooler
  - Heating Options
    - Indirect gas furnace
      - Stainless steel construction
      - High turndown capacity (up to 16:1)
      - Power venting
    - Electric heat
      - SCR control
      - Optional single-point power
    - Hot water coil
    - Water-source heat pump

## Model Number Code

The model number code is designed to completely identify the unit. The correct code letters must be specified to designate the configurations and size.

**ERCH - 55 - 30H - 20P - IG - 01**

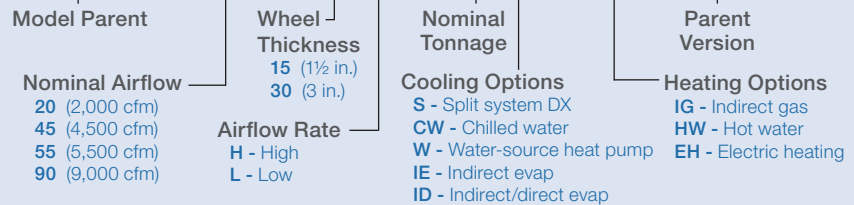

## Product Certifications

Greenheck takes pride in offering a high quality, reliable product. We invest our resources into designing, testing and manufacturing products to ensure customer satisfaction.



ETL Listed for electrical and overall unit safety. Every unit is tested at the factory before it is shipped to the jobsite.



Energy recovery wheels are certified by the AHRI Air-to-Air Energy Recovery Ventilation Equipment Certification Program in accordance with AHRI Standard 1060.

## 100% Outdoor Air System

Single-zone applications often require large amounts of outside air to satisfy ventilation requirements. Model ERCH is a 100% outside air unit designed to condition the outdoor air loads imposed on these systems. With total energy recovery, high-capacity heating and cooling options, and optional pre-programmed microprocessor control, this unit can efficiently maintain space temperature and humidity.

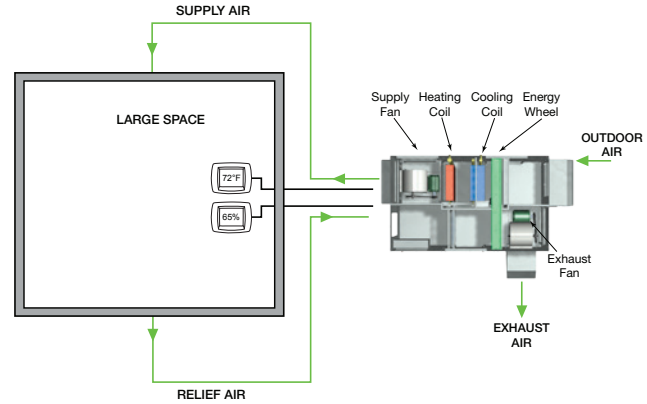

## Dedicated Outdoor Air System

A dedicated outdoor air system (DOAS) is a multiple zone application often utilized in schools, offices, and dormitories. These systems incorporate a dedicated outdoor air unit that handles 100% outside air and terminal units at each space. The outdoor air unit handles the latent load, or dehumidification of the outdoor air, and the terminal units handle the sensible load, or the temperature in their respective space. The separation of the load components allows for much better humidity control and for more accurate verification that the ventilation requirements are met for each space. Greenheck's model ERCH has the versatility and capability to serve as an exceptional dedicated outdoor air unit.

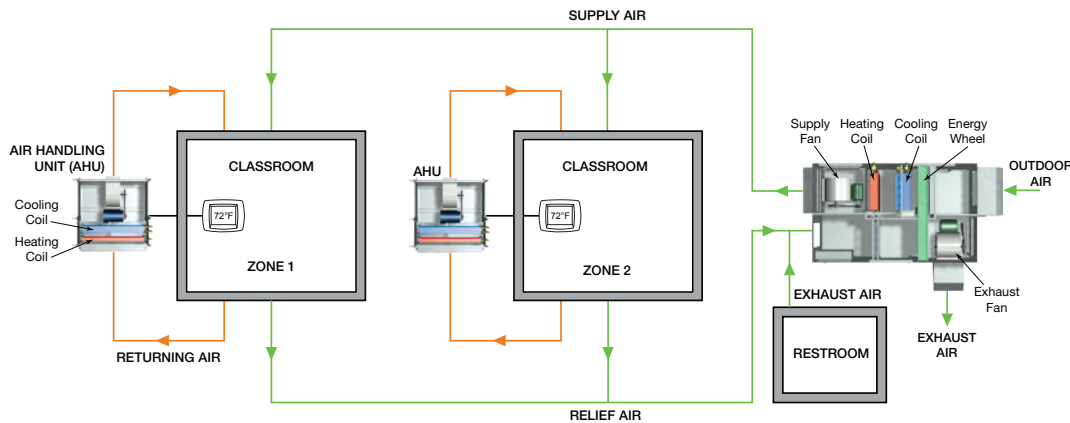

Unit Features	System Benefits
Total energy recovery	Reduced heating and cooling loads and operating costs
Optional reheat	Superior humidity control
Factory-written control sequences	Tested and proven unit performance in various applications
Building management system monitoring and control integration capabilities	Integrates to BACnet <sup>®</sup> MS/TP or IP, LonWorks <sup>®</sup> or Modbus <sup>®</sup> RTU protocols
Configuration flexibility	Various duct connection capabilities simplifying installation
Optional high turndown indirect gas furnace	Accurate temperature control and decreased furnace cycling

## Typical Applications for Energy Recovery

- Animal shelters
- Churches
- Locker rooms
- Office buildings
- Restaurants
- Function halls
- Bars and clubs
- Dormitories
- Nursing homes
- Printing shops
- Schools
- Veterinary hospitals



## How does energy recovery work?

Energy recovery is the process through which energy is transferred between the conditioned return air from the space and the fresh outdoor air which imposes the load on the equipment. This is done by rotating an energy wheel between the two airstreams. All energy wheels include:

- Polymer heat transfer media for sensible energy transfer
- Silica gel desiccant permanently bonded to polymer media for latent energy transfer
- Removable segments for ease of maintenance
- Five-year manufacturer's warranty

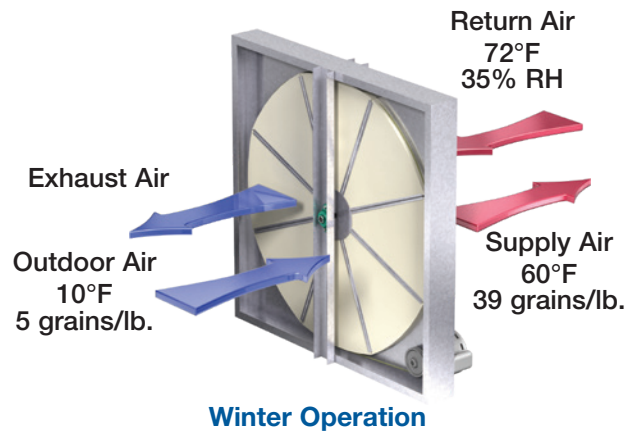
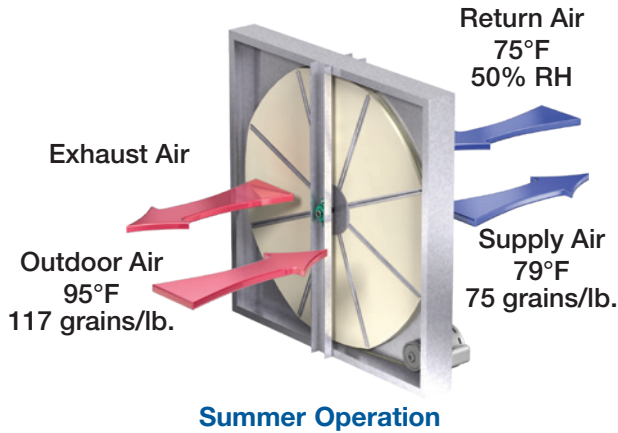

## Why use energy recovery?

A 100% outdoor air unit's primary responsibility is to dehumidify the incoming air, however, it inherently handles large heating and cooling loads in the process. The addition of energy recovery significantly reduces the size of the equipment required to sufficiently condition this air.

ASHRAE 90.1-2010 requires the use of energy recovery based upon a unit's supply airflow, outdoor air percentage, and geographic location. The standard mandates the total effectiveness (sensible and latent) be a minimum of 50% when required.

The effectiveness of energy recovery devices varies depending on the device type, material, and airflow balance. This value is determined based on the test procedure outlined in the Air-Conditioning, Heating, and Refrigeration Institution (AHRI) Standard 1060.

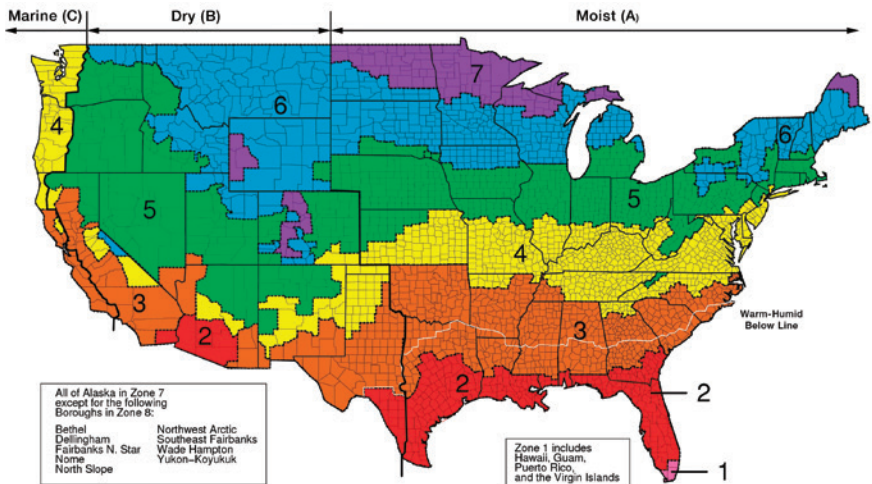

Zone	Percentage of Outdoor Air at Full Design Airflow Rate (CFM)					
	30% ≤ 40%	40% ≤ 50%	50% ≤ 60%	60% ≤ 70%	70% ≤ 80%	≥ 80%
Design Supply Fan Airflow Rate (CFM)						
3B, 3C, 4B, 4C, 5B	NR	NR	NR	NR	≥ 5,000	≥ 5,000
1B, 2B, 5C	NR	NR	≥ 26,000	≥ 12,000	≥ 5,000	≥ 4,000
6B	≥ 11,000	≥ 5,500	≥ 4,500	≥ 3,500	≥ 2,500	≥ 1,500
1A, 2A, 3A, 4A, 5A, 6A	≥ 5,500	≥ 4,500	≥ 3,500	≥ 2,000	≥ 1,000	≥ 0
7, 8	≥ 2,500	≥ 1,000	≥ 0	≥ 0	≥ 0	≥ 0

NR = Not recommended

## Microprocessor

In addition to standard analog control, Greenheck offers the following direct digital control options.



The model ERCH offers an optional microprocessor controller that is factory-programmed, wired and tested prior to shipment. The controller can operate stand-alone or integrate with a Building Management System (BMS) using BACnet<sup>®</sup> MS/TP or IP, LonWorks<sup>®</sup> or Modbus<sup>®</sup> RTU protocols. This controller is responsible for operating the unit in a safe and energy-efficient manner while controlling temperature and humidity.

### Control Features:

- LCD display
- Built-in keypad for easy set point adjustment
- Integral 7-day time clock
- Night setback option
- Auto changeover based on outdoor air conditions
- Heating and cooling temperature lockouts
- Building freeze protection
- Optional remote interface for service convenience
- Room temperature and humidity control

### Optional Control Sequences:

#### Energy Wheel Frost Control

Prevents frost buildup on the energy wheel in climates that have cold outdoor winter temperatures (typically less than -10°F) and/or moist indoor conditions such as a locker room. Available options are:

- **Timed exhaust** - Cycles supply blower to melt frost with only warm return air.
- **Electric preheat** - Preheats outdoor air to avoid frosting.
- **Modulate wheel** - Reduces the wheel speed to increase the time exposed in the warm, return air.

#### Energy Wheel Economizer Control

When the outdoor air conditions are favorable, the controller will allow for economizer operation. The unit will increase outdoor airflow to achieve free cooling by adjusting the energy wheel operation to:

- **Stop wheel** - Energy wheel rotation will stop and outdoor air can be brought into the building unconditioned.
- **Modulate wheel** - Energy wheel speed will modulate to maintain a leaving wheel temperature of 55°F (adjustable).

#### Fan Control

- **Constant volume** - Provides a constant volume of supply air to meet the space ventilation requirements.
- **Variable volume** - Varies the supply air to the space via a factory-mounted and wired variable frequency drive. The required amount of supply air can be determined by a variety of external factors such as duct pressure.
- **Demand control** - The supply air volume (100% outdoor air application), is modulated based on building occupancy as determined by a factory provided CO<sub>2</sub> sensor.

## Network Interface



The network interface offers an easy-to-use, factory-mounted display which can monitor many set points within the unit to verify proper operation and assist with maintenance notification without the need for full microprocessor capabilities. It easily integrates to BACnet<sup>®</sup> MS/TP or IP, LonWorks<sup>®</sup> or Modbus<sup>®</sup> RTU. One operating option is available:

- **Monitor** - Allows the BMS to monitor the status and functions of the unit through a factory-installed controller.

## 1 Weatherhood

- Downturn or louvered intake hood
- 2-inch aluminum mesh filters (mist eliminating)
- Exhaust hood with integral backdraft damper

## 2 Construction

- Double-wall construction with 1-inch insulation secured in place between solid inner and outer panels
- Insulation density of 1.5 lbs/cu. ft.
- Easy lift-off removable hinged access doors with stainless steel hinges and quarter turn latches

## 3 Exhaust and Supply Fan

- Double-width, double-inlet forward-curved wheels
- Neoprene or spring isolation
- Optional factory provided VFD

## 4 Filters

- 2-inch MERV 8 or MERV 8 and 13 in outdoor airstream
- 2-inch MERV 8 in return airstream

## 5 Total Energy Wheel

- Sensible and latent energy recovery
- Lightweight, segmented wheel for easy cleaning
- L<sub>10</sub> rated bearing life in excess of 400,000 hours
- Permanently bonded, silica gel desiccant for latent transfer — long term durability
- Stainless steel housing
- Five year manufacturer's warranty

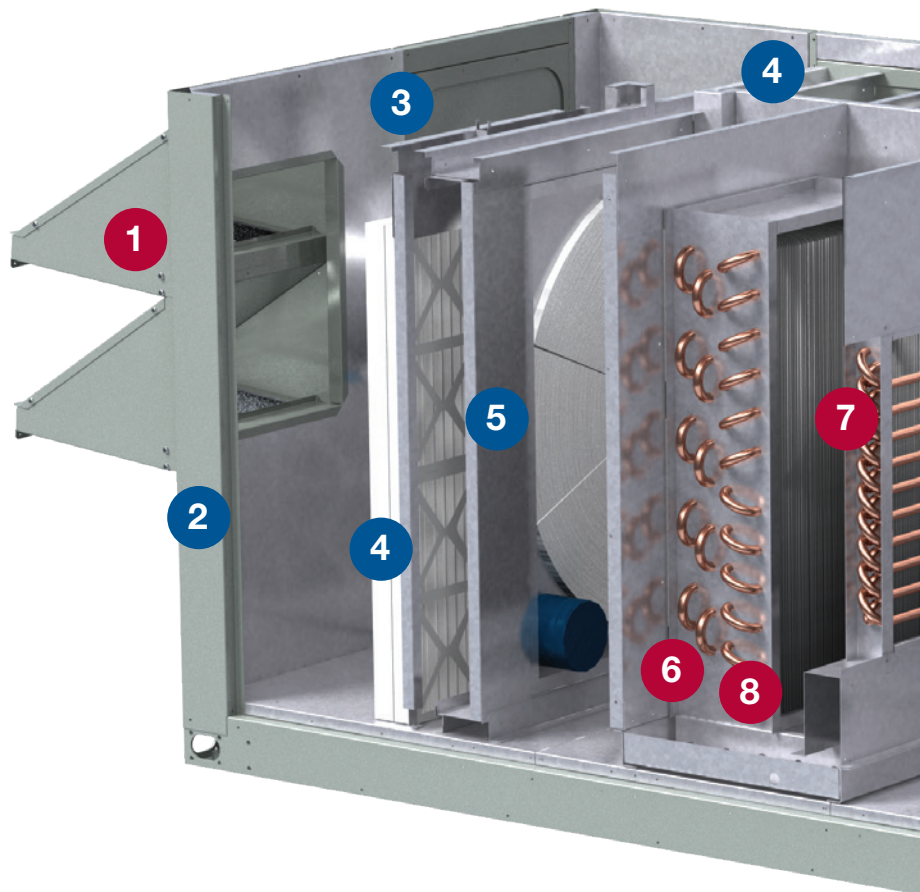

## 6 Cooling Options

- Split DX coil (coil only)
- Chilled water coils (optional piping vestibule)
- Water-source heat pump (WSHP)
- Evaporative cooler
- All cooling options come standard with a stainless steel drain pan.



## 7 Reheat Options

- Modulating hot gas reheat (HGRH)

**S** Standard Feature

**O** Optional Feature

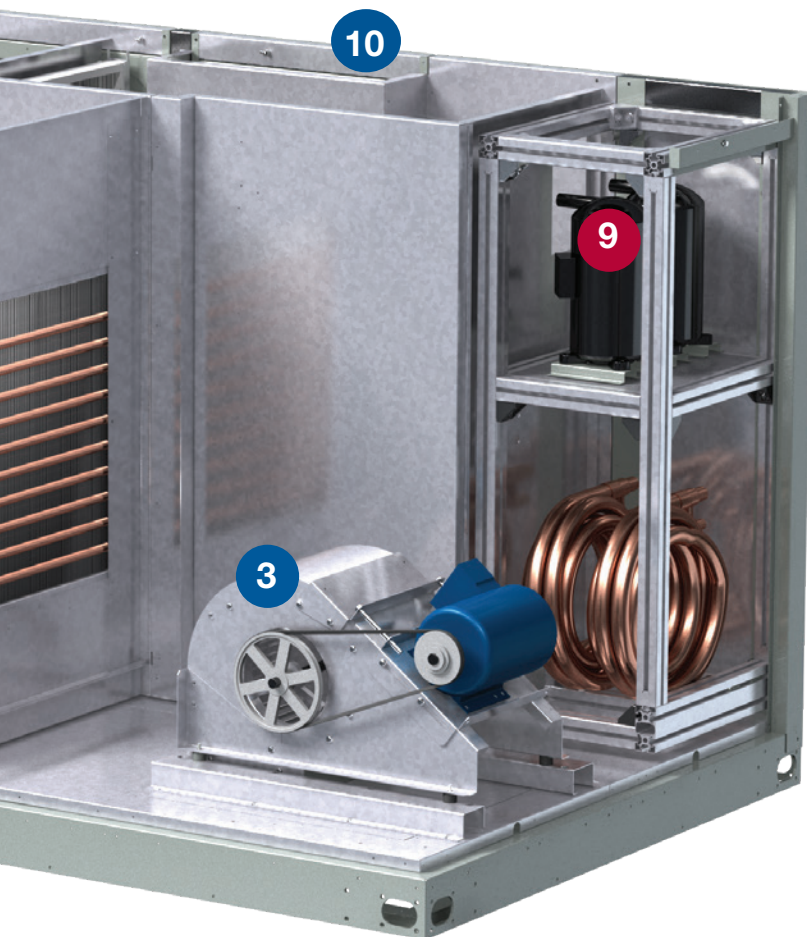

### Optional Accessories

- Outdoor airflow monitor
- Energy wheel frost control
- Energy wheel rotation sensor
- Energy wheel economizer control
- CO<sub>2</sub> sensor
- Outdoor/return dampers
- Unoccupied recirculation damper
- Remote control panel
- Factory-mounted sensors
- Dirty filter sensor
- Service receptacle
- Roof curbs
- Smoke detectors
- Microprocessor remote interface
- Additional monitoring points
- Room temperature sensor
- Room dehumidistat
- Room humidity sensor

## 9 Compressors (WSHP only)

- Quiet running hermetic, scroll-type
- 4 to 30 tons of mechanical cooling
- 1 circuit up to 10 tons
- 2 circuits 10 tons and over

## 8 Heating Options

- Indirect gas furnace
  - Optional high turndown furnace (up to 16:1)
- Hot water coils (optional piping vestibule)
- Electric heater
- Water-source heat pump (shown)

## 10 Control Center

- 24 VAC control voltage
- Control transformer
- Disconnect switch
- UL Listed, Recognized or Classified electrical components
- Factory-wired for single point power connection
- Phase and brownout protection (standard with WSHP)

Model	A	B	C	D	E	Approx. Weight (lbs)*	Airflow Range (CFM)
ERCH-20	76.2	54.2	54.3	17.7	20.8	1550	1,000 - 2,200
ERCH-45	84.3	70.2	64.4	21.7	20.7	2325	2,200 - 4,400
ERCH-55	97.5	71	75.2	21.7	23.6	3000	4,200 - 6,000
ERCH-90	109.5	89	94.5	26.7	25.5	4300	6,000 - 10,000

All dimensions are shown in inches.

\*All weights include weatherhood, indirect gas furnace, supply and exhaust filters.

Available Intake/Discharge Positions				
	Bottom	Top	Side	End
OA Intake		X		X
SA Discharge	X	X		X
RA Intake	X	X		X
EA Discharge		X	X	X

Top position only available when indoor mounting is selected.

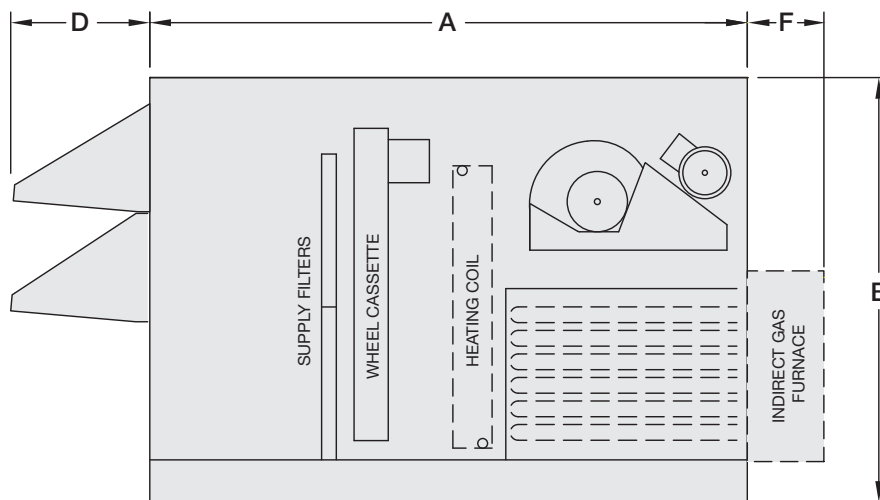
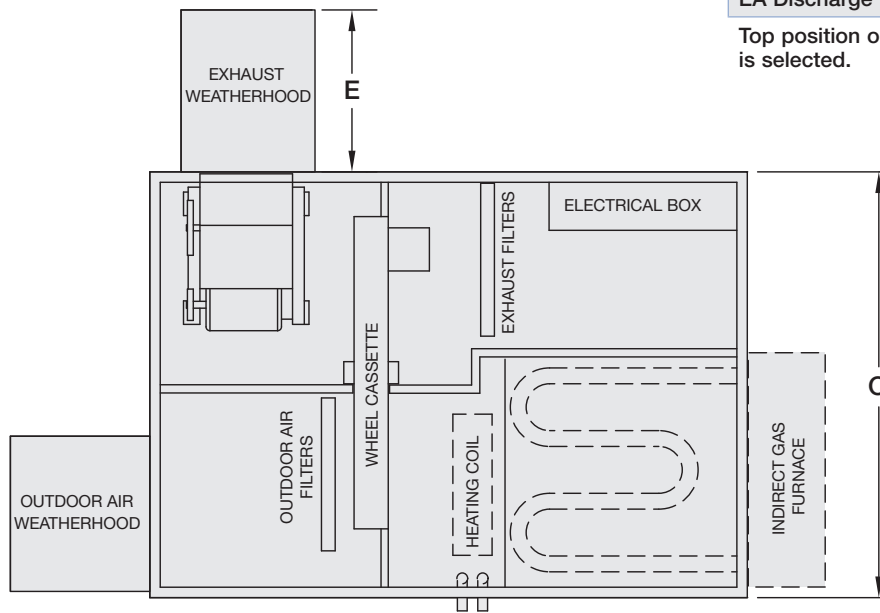

Drawings show both heating coil and indirect gas furnace options. Electric heat is also available. Only one can be selected.



# Cooling Coil (with or without heating)

Model	A	B	C	D	E	F	Approx. Weight (lbs)*	Airflow Range (CFM)
ERCH-20	96.2	54.2	54.3	17.7	20.8	9.8	1825	1,000 - 2,200
ERCH-45	104.3	70.2	64.4	21.7	20.7	9.8	2725	2,200 - 4,400
ERCH-55	97.5	71	75.2	21.7	23.6	9.8	3475	4,200 - 6,000
ERCH-90	119.5	89	94.5	26.7	25.5	9.8	5050	6,000 - 10,000

All dimensions are shown in inches.

\*All weights include weatherhood, indirect gas furnace, cooling coil, heating coil, supply and exhaust filters.

Available Intake/Discharge Positions				
	Bottom	Top	Side	End
OA Intake		X		X
SA Discharge	X	X		X
RA Intake	X	X		X
EA Discharge		X	X	X

Top position only available when indoor mounting is selected.

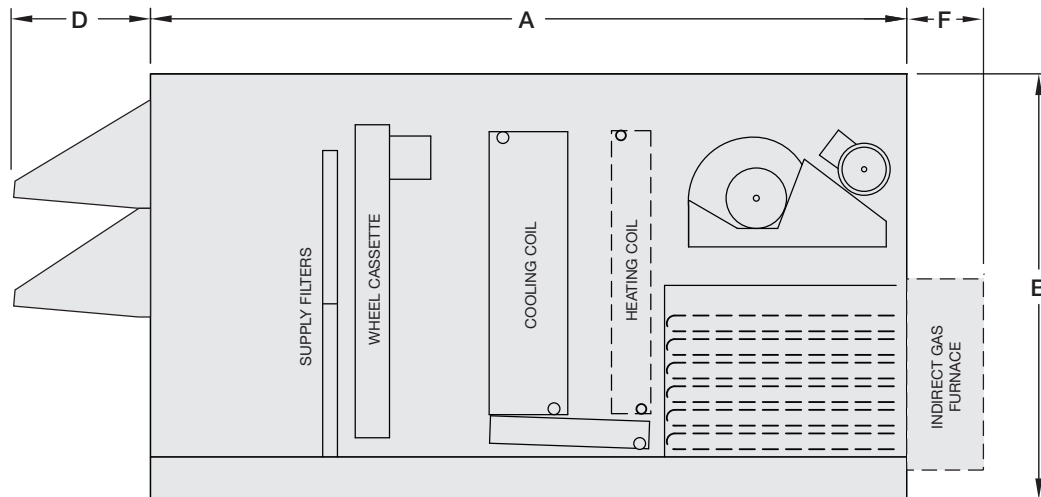
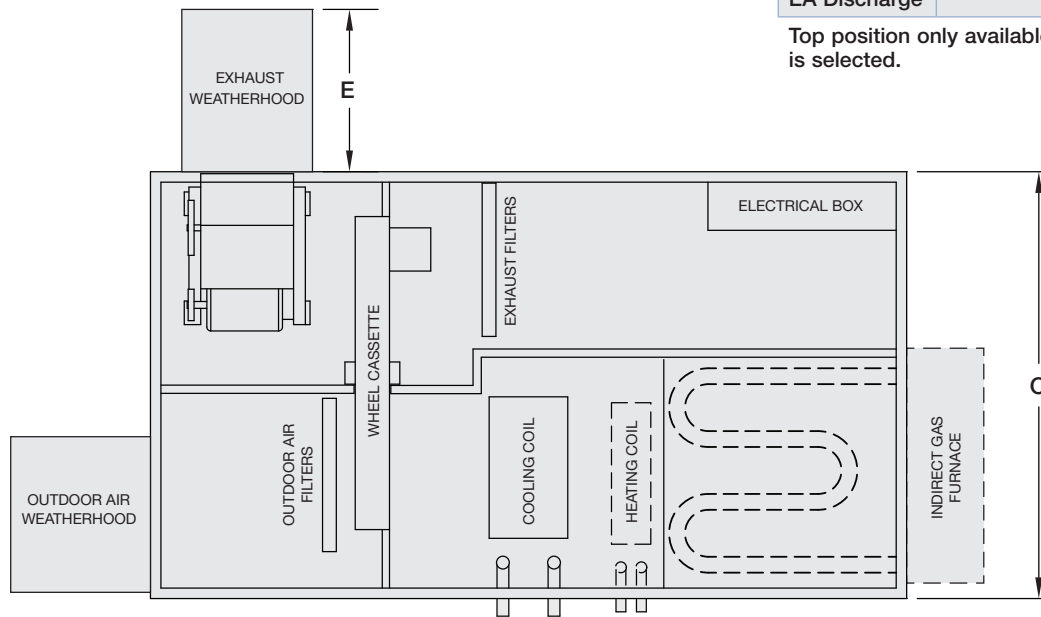

Drawings show both heating coil and indirect gas furnace options. Only one can be selected.

# Water-Source Heat Pump

Model	A	B	C	D	E	Approx. Weight (lbs)*	Airflow Range (CFM)
ERCH-20	108.2	54.2	54.3	17.7	20.8	2350	1,000 - 2,200
ERCH-45	119.3	70.2	64.4	21.7	20.7	3775	2,200 - 4,400
ERCH-55	133.5	71	75.2	21.7	23.6	4725	4,200 - 6,000
ERCH-90	151.5	89	94.5	26.7	25.5	6450	6,000 - 10,000

All dimensions are shown in inches.

\*All weights include weatherhood, hot gas reheat coil, cooling coil, supply and exhaust filters.

Available Intake/Discharge Positions				
	Bottom	Top	Side	End
OA Intake		X		X
SA Discharge	X	X	X	X
RA Intake	X	X	X	
EA Discharge		X	X	X

Top position only available when indoor mounting is selected.

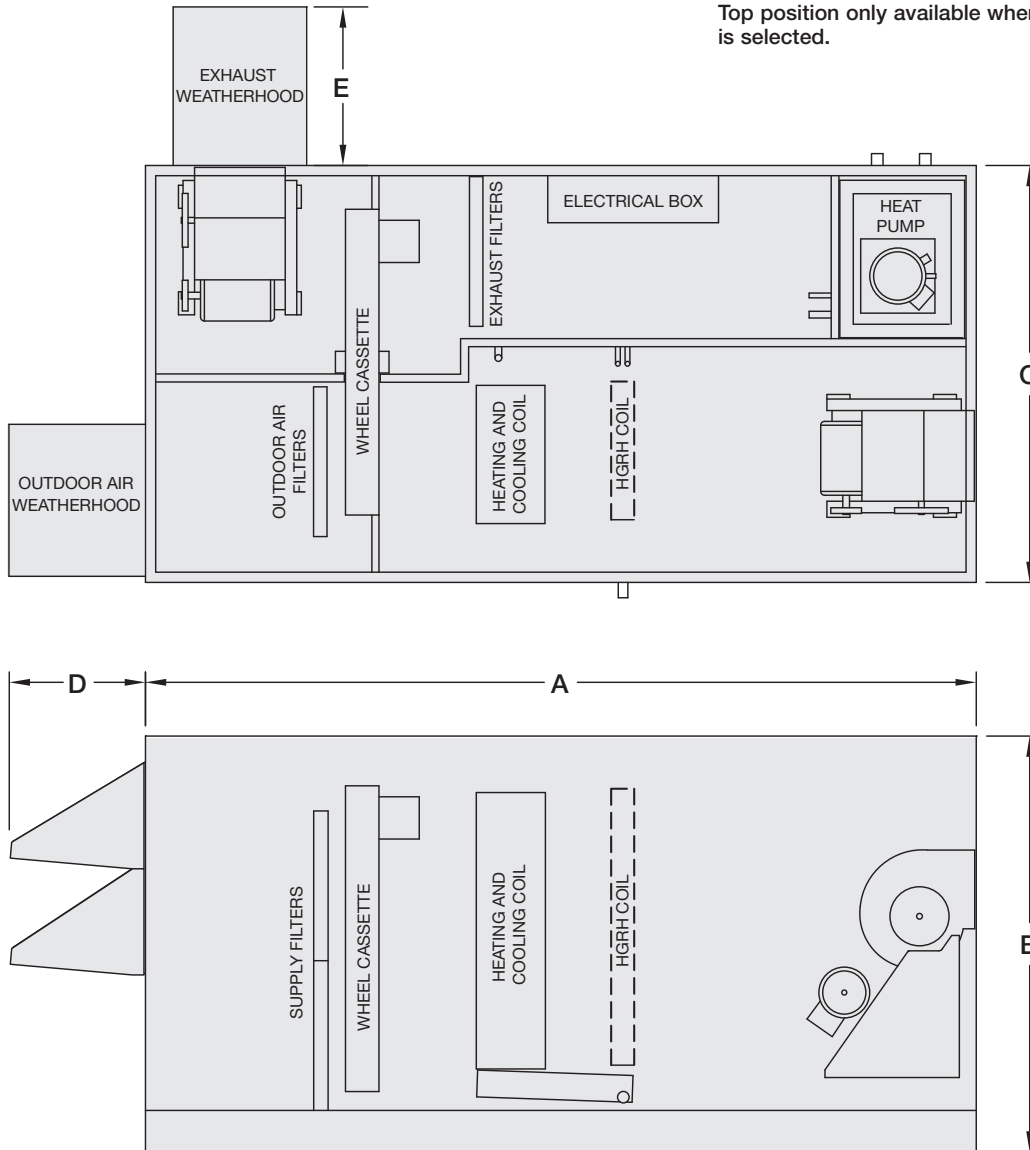

Drawings show optional hot gas reheat coil.

Model	A	B	C	D	E	F	Approx. Weight (lbs)*	Airflow Range (CFM)
ERCH-20	108.2	54.2	54.3	17.7	20.8	9.8	1800	1,000 - 2,000
ERCH-45	119.3	70.2	64.4	21.7	20.7	9.8	2900	2,000 - 4,100
ERCH-55	133.5	71	75.2	21.7	23.6	9.8	3325	4,100 - 5,500
ERCH-90	151.5	89	94.5	26.7	25.5	9.8	5400	5,500 - 8,300

All dimensions are shown in inches.

\*All weights include weatherhood, indirect gas furnace, supply and exhaust filters.

Available Intake/Discharge Positions				
	Bottom	Top	Side	End
OA Intake		X		X
SA Discharge	X	X		X
RA Intake	X	X		X
EA Discharge		X	X	X

Top position only available when indoor mounting is selected.

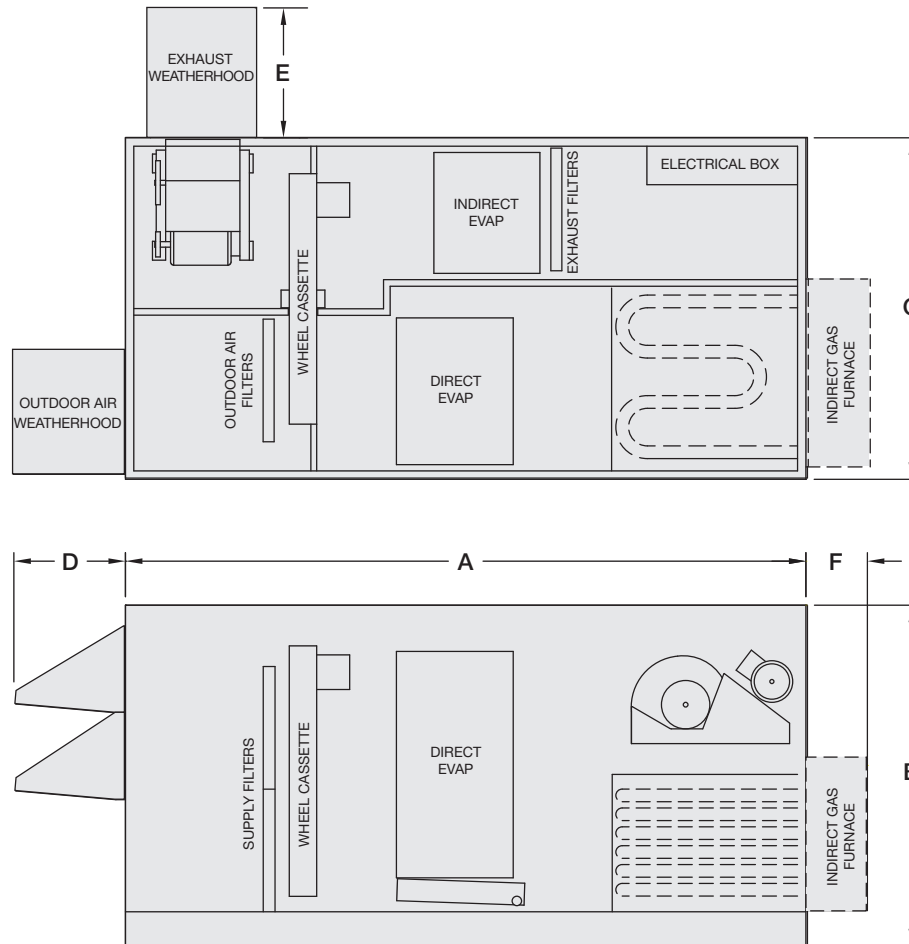

Drawings show optional indirect gas furnace. Electric heat is also available. Only one can be selected.



# Dedicated Outdoor Air Systems Models RV and RVE



## Challenge: Conditioning High Percentage Outdoor Air with Minimal Energy Usage

Solution



- High-capacity (6-row) cooling coil
- 2-inch double-wall R13 foam construction
- Energy recovery wheel to precondition the outdoor air *(optional)*
- Modulating hot gas reheat coil *(optional)*
- Inverter compressor *(optional)*
- High turndown indirect gas-fired furnace *(optional)*
- Modulating head pressure control *(optional)*
- Air-source heat pump *(optional)*

## Challenge: Controlling Outdoor Air Volume

Solution



- Low leakage dampers with modulating actuator
- Factory-mounted and wired microprocessor controller
- Energy efficient control sequences
- Direct-drive plenum fan with factory-mounted VFD
- Remote monitor and control from web-user interface

## Challenge: Critical Sound Applications

Solution



- Low sound condenser fans
- Radiated sound data off five planes of unit tested at full load
- 2-inch double-wall cabinet with R13 injected foam insulation
- Compressor isolation
- Inverter scroll at part load *(optional)*
- Electronically commutated (EC) motor *(optional)*

## Challenge: Finding a Manufacturer Dedicated to Outdoor Air

Solution



Models RV and RVE  
3 to 70 tons  
500 to 18,000 cfm

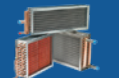
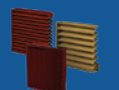
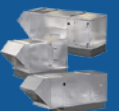
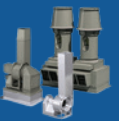

## Our Commitment

As a result of our commitment to continuous improvement, Greenheck reserves the right to change specifications without notice.

Specific Greenheck product warranties are located on [greenheck.com](http://greenheck.com) within the product area tabs and in the Library under Warranties.

Greenheck P.O. Box 410 • Schofield, WI 54476-0410 • Phone (715) 359-6171 • [greenheck.com](http://greenheck.com)

Copyright © 2021 Greenheck Fan Corp. • 00.TAP:1005 R8 11-2021