

# Indirect Gas-Fired Technical Guide



# Table of Contents

Model Name Description .....2

Technical Guide: Heat Exchange Material Design .....3

Technical Guide: S-Tube Furnace Design .....4

Model IG or IGX? .....5

Model IG Performance Data .....6

Model IG Unit Dimensions and Weights .....7

Model IG Roof Curbs .....8

Model IG Evaporative Cooling .....9

Model IGX Performance Data & Motor Weights .....10

Model IGX Unit Dimensions and Weights ..... 11-12

Model IGX Roof Curbs .....13

Model IGX Evaporative Cooling .....14

Model IGX DX and Chilled Water Cooling Coil .....15

Furnace Venting Options ..... 16-17

Weatherhood & Filter Options .....18

Diffuser Options .....19

Make-Up Air Furnace and Temperature Controls .....20

Technical Guide: Furnace Control and Turndown Ratio .....21

Make-Up Air - Airflow and Evaporative Cooling Controls .....22

Industrial Make-Up Air Temperature Control Recommendation .....23

TSCP Industrial Type Remote Control Panel .....24

Commercial Kitchen Make-Up Air Temperature Control Recommendation .....25

Make-Up Air Controls .....26

Heating & Ventilating Controls ..... 28-30

IG Typical Specification .....32

IGX Typical Specification .....33

IG-HV Typical Specification .....34

IGX-HV Typical Specification .....35

Make-Up Air Product Selection Guide .....36



Indirect Gas Furnace is ETL and cETL listed to ANSI Z83.8-2002  
 Indirect Gas Units are listed to UL1995.  
 Both are harmonized standards between USA and Canada

## Model Name Description

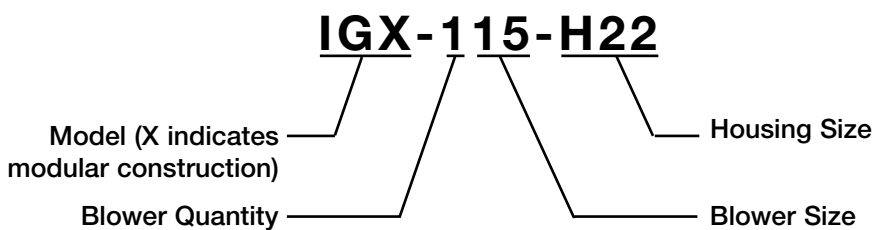

# Technical Guide: Heat Exchanger Material Selection

One important consideration when selecting an indirect gas-fired furnace for a make-up air or heating and ventilating application is the heat exchanger material. The conditions created inside of the heat exchanger by the combustion process are the greatest factor limiting the life of the furnace. Selecting the proper heat exchanger material can greatly reduce the effects of these conditions and yield a long furnace life. To select the best heat exchanger material, the application and climate should be considered.

## Corrosion and Thermal Expansion:

The first factor limiting the life of the heat exchanger is the by-products of the combustion process. During combustion process, water, nitrogen and sulfur form inside of the heat exchanger, creating a highly corrosive environment. The second factor is the high temperature of the heat exchanger. Like any material, a heat exchanger expands and contracts with changes in temperature. The expansion and contraction leads to high stresses in the heat exchanger. The corrosive conditions, combined with high stress can reduce furnace life if the wrong heat exchanger material is selected.

## Available Materials:

Greenheck offers two material options for heat exchangers: aluminized steel and stainless steel. Both are selected for the specific application of indirect gas-fired heat exchangers, but have different strengths.

The first material option is aluminized steel—steel that has been hot dipped in a molten aluminum bath. The result is a triple layer of protection on the inside and outside of the heat exchanger. The first protective layer is an aluminum coating that is the first line of defense against the corrosive conditions. Between the aluminum and the steel is a second protective alloy layer. As the outer aluminum corrodes, aluminum oxide forms and provides a third layer of protection. In order for the steel to begin corrosion, condensation must penetrate the aluminum oxide, aluminum and the alloy.

Stainless steel is the second available material option. Stainless gets its corrosive resistive properties from its chromium content. As stainless is exposed to a corrosive environment the chromium oxidizes and forms a single protective layer over the steel that slows corrosion.

Both materials are very effective at resisting corrosion, but stainless holds up better to the extreme temperatures found in some common applications. As aluminized steel approaches 1100°F the aluminum begins scaling, exposing the steel. This temperature corresponds to an airstream temperature rise of approximately 70°F. However, at temperatures below the aluminized steel scaling point, the aluminized steel tends to outperform stainless steel with respect

to heat stress cracking. From this information, Greenheck recommends aluminized steel for temperature rises of 60°F or less and stainless for temperature rises greater than 60°F.



## Application and Climate Considerations:

Other than a corrosive environment, the airstream temperature rise is the largest factor driving heat exchanger material selection. With this in mind, we will consider two distinct applications for indirect gas-fired heaters: heating and ventilating and make-up air. From this, guidelines can be created to properly select the heat exchanger material.

Most heating and ventilating applications use a small amount of outside air (0-30%)

Winter Design Temp.	Outside Air Percentage	Mixed Air Temp.	Required Temp. Rise*	Recommended Heat Exchanger Material
-20	15	57	34	Aluminized
-20	30	43	47	Aluminized
0	15	60	31	Aluminized
0	30	49	41	Aluminized
30	15	64	26	Aluminized
30	30	58	32	Aluminized

\*Assumes 70°F space temperature and 90°F discharge temperature

which is mixed with a large amount of recirculated room air (70-100%). The relatively warm mixed air typically requires a temperature rise less than 50°F, as illustrated in the table above. As a result, aluminized steel heat exchangers are recommended for heating and ventilating applications.

Make-up air applications are 100% outside air. As a result, the required temperature rise of the heat exchanger depends heavily on the climate. In mild climates, with outdoor winter design temperatures above 10°F, a temperature rise of 60°F or less is typical and aluminized steel is recommended (based upon a 70°F discharge temperature). In colder climates with outdoor winter design temperatures less than 10°F, the airstream temperature rise often exceeds 60°F. When this occurs, stainless steel is recommended.

Winter Design Temp.	Required Temp. Rise*	Recommended Heat Exchanger Material
-10	80	Stainless
0	70	Stainless
10	60	Aluminized
20	50	Aluminized
30	40	Aluminized

\*Assumes a discharge temperature of 70°F

## Summary:

For heating and ventilating applications and make-up air applications in mild climates where the airstream temperature rise is less than 60°F, aluminized steel will offer long furnace life and minimize the chance of heat exchanger stress cracking. For make-up air applications in cold climates where airstream temperature rise exceeds 60°F, stainless steel is recommended.

# Technical Guide: S-Tube Furnace Design

## The Problem

Many of today's indirect gas-fired make-up furnace specifications are based on yesterday's technology and often call for unneeded components that add unneeded cost. Yesterday's furnaces often featured a clamshell style heat exchanger, which due to inherent design problems resulted in condensation on the burner and in the housing. To manage the condensation and prevent corrosion, most clamshell specifications call for stainless steel burners and drip pans. Greenheck's s-tube style furnace first limits condensation, then manages any condensation that does occur in a way that eliminates the need for stainless steel burners and drip pans.

The largest inherent problem with a clamshell furnace is the vertical heat exchanger configuration. The burners fire vertically up into the heat exchanger. The hot combustion gases travel up the straight single pass heat exchangers and collect at the top where they are vented. Because of the vertical configuration, any condensation that develops in the heat exchanger falls onto the burner and runs into the furnace housing. The condensation contains by-products of combustion, which are highly corrosive and destroy the furnace. To protect the furnace section and maintain an acceptable life, clamshell furnaces include costly stainless steel burners and drip pans.

Many clamshell furnaces are gravity vented, which is another problem that makes stainless steel burners and drip pans necessary. Gravity venting means that the combustion gases naturally vent through a stack, like smoke in a fireplace naturally escapes through a chimney. Gravity vented furnace efficiency is dependent on the outside conditions. Wind blowing over the stack can push the efficiency too high, resulting in excessive condensation. Even more condensation will develop when the furnace shuts down. Any combustion gases remaining in the heat exchanger will cool, condense and run down onto the burner and into the housing.

Clamshell furnaces also present a significant design limitation. The manifold, burners and drip pan are located under the heat exchanger, preventing a downblast discharge from the furnace section. If your application calls for a downblast discharge, an additional downturned section is required which increases the unit footprint and cost.

## The S-Tube Solution

Greenheck's furnace design features horizontally firing burners and power venting with post purge cycle which together provide flexibility, maximum heat exchanger life and make stainless steel burners unnecessary and drip pans obsolete.

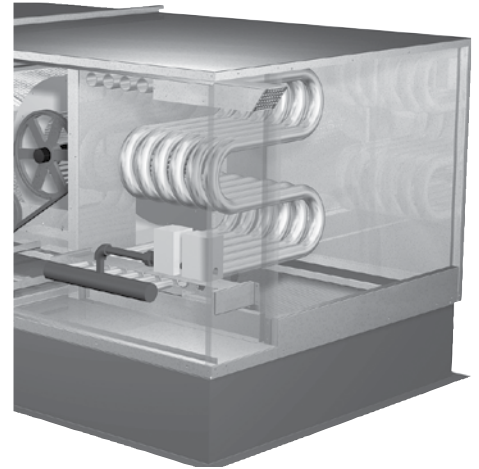

Power venting maintains optimum combustion levels, helping prevent the furnace efficiency from reaching the level where condensation begins. The combustion blower also enables a post purge cycle. When the furnace shuts down, the combustion blower continues to run, venting any combustion gases and drying the heat exchanger. Unless removed, this combination of gases and moisture would attack the inside of the heat exchanger and promote corrosion.

Greenheck's horizontally firing heat exchanger means that the burners, manifold and gas train are located on the side of the furnace, rather than below it. And unlike a clamshell furnace, there is no drain pan under the furnace. With the bottom of the furnace free and clear, a downblast discharge is easily integrated into the furnace section. Unlike a clamshell style furnace, Greenheck's furnace offers you the same compact design, whether your application calls for a horizontal or downblast discharge. The horizontally firing heat exchanger also stops condensation from dripping onto the burners and into the housing. Any condensation will remain in the corrosion resistant heat exchanger until it is power vented to the outdoors.

### Summary

When your application calls for indirect gas-fired make-up air, be sure to specify the latest technology. Horizontally firing burners and s-tube heat exchangers with power venting and post purge cycle guarantee a long furnace life in the most compact and flexible unit configuration available.

# Model IG or IGX?

Greenheck offers two models of indirect gas-fired make-up air and heating units. Both IG and IGX models include the following features and options:

- Stainless steel or aluminized heat exchanger
- 80% thermal efficiency
- Power vented furnace with post purge cycle
- Double-wall furnace section
- G90 galvanized steel housing
- Factory wired control center

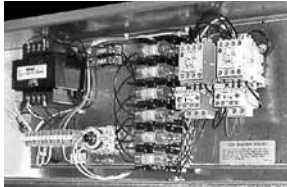

- Single-point power connection
- Optional painted finish
- Optional separated combustion for indoor installations

- Optional evaporative cooling



- Optional mixing box with controls



The Model IG has a less complex design and therefore typically offers the most economical solutions. The information below identifies application parameters for the IG and IGX.

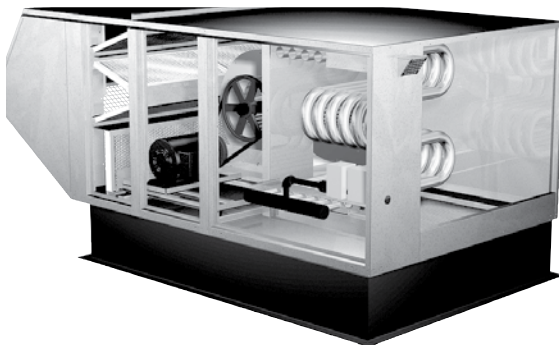

**Model IG**

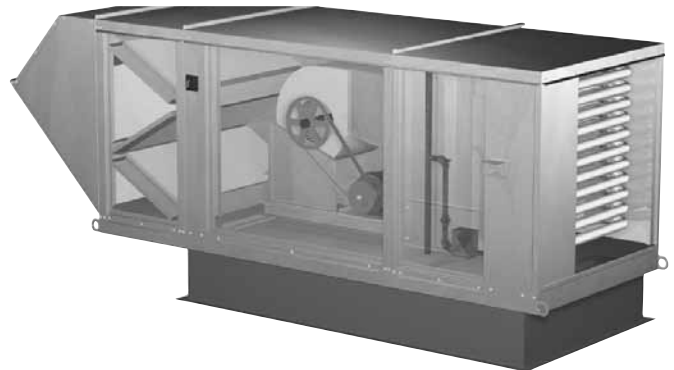

**Model IGX**

## Model IG

- Airflow up to 7,000 cfm
- Heat up to 400 MBH
- Single-speed fan

## Model IGX

- Airflow up to 15,000 cfm
- Heating up to 1,200 MBH
- Two speed fan option
- Variable volume fan option
- DX and chilled water cooling options
- Occupied / Unoccupied control option (IGX-HV Only)

# Model IG Performance Data

## Air Performance Data & Furnace Availability

Model	Housing	MBH (input)		CFM	RPM/BHP	Total Static Pressure in inches of WG				
		Min.	Max			0.75	1.00	1.25	1.50	1.75
IG-108	H10	75	125	800	RPM	1109	1216	1311	1399	-
					BHP	0.26	0.31	0.35	0.40	-
				1,200	RPM	1347	1445	1530	-	-
					BHP	0.59	0.68	0.75	-	-
IG-109	H10	75	175	1,400	RPM	998	1128	1245	1352	1456
					BHP	0.41	0.48	0.57	0.67	0.78
	H20	75	250	2,400	RPM	1216	1306	1397	1484	1569
					BHP	1.10	1.31	1.40	1.60	1.70
IG-110	H10	150	175	2,000	RPM	912	1013	1110	1199	-
	H20	200	300		BHP	0.59	0.71	0.80	1.0	-
	H30	325	400	3,000	RPM	1097	1172	1244	1315	1386
					BHP	1.4	1.6	1.7	1.9	2.1
IG-112	H20	175	300	2,600	RPM	761	853	934	1009	-
					BHP	0.7	0.9	1.0	1.2	-
	H30	175	400	4,400	RPM	939	1006	1073	1137	1197
					BHP	2.1	2.4	2.6	2.9	3.1
IG-115	H20	250	300	4,000	RPM	681	756	822	892	-
					BHP	1.3	1.5	1.8	2.1	-
	H30	250	400	7,000	RPM	889	943	994	1044	1093
					BHP	4.2	4.6	5.0	5.5	5.9

Note: The air performance data shown does not include internal static pressure losses due to items such as filters, dampers and furnaces. For exact air performance data based on specific unit configuration, use the Greenheck CAPS selection program.

## IG Pressure Loss Table

Housing Size	CFM	Housing	Louvered Weatherhood	Aluminum Mesh V-Bank Filters	Inlet Damper	Furnace	Evaporative Cooler
H10	1200	0.12	0.02	< 0.01	< 0.01	0.23	0.03
	2400	0.25	0.10	0.03	0.01	0.90	0.12
	3000	0.26	0.16	0.04	0.02	1.41	0.19
H20	1500	0.10	0.03	< 0.01	< 0.01	0.12	0.05
	3000	0.26	0.10	0.03	0.01	0.50	0.19
	4400	0.34	0.23	0.06	0.03	1.07	0.20
H30	3000	0.16	0.10	0.03	0.01	0.23	0.19
	5000	0.23	0.29	0.08	0.03	0.65	0.26
	7000	0.45	0.57	0.15	0.07	1.28	0.50

## IG Maximum Motor Size

Maximum Motor Size by Fan Size					
Housing	108	109	110	112	115
H10	¾	1½	3	-	-
H20	-	3	3	5	5
H30	-	-	3	5	7½

Note: The 3, 5, and 7½ hp motors are not available with 115V supply power. The 7½ hp motor is only available with 3 phase supply power.

# Model IG Unit Dimensions

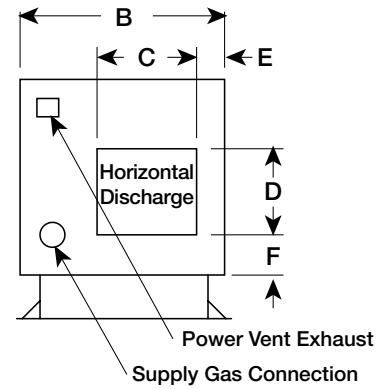
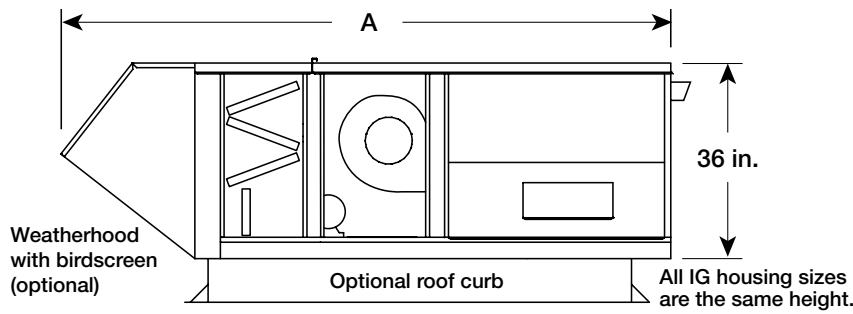

## Model IG Unit Base Unit Dimensions

Housing	A					Width
	100% Outside Air			Recirculation		
	Louvered Weatherhood	Birdscreen Weatherhood	No Weatherhood	Louvered Weatherhood	No Weatherhood	
H10	84.7	99.0	73.1	101.3	89.8	43.5
H20	87.6	102.0	76.2	104.3	92.8	52.6
H30	96.6	111.0	85.2	113.3	101.9	

## Model IG Horizontal Discharge Dimensions

Housing	B	C	D	E	F
H10	43.6	30.2	21.0	1.8	5.0
H20	52.6	39.2		1.0	
H30					

All dimensions are shown in inches

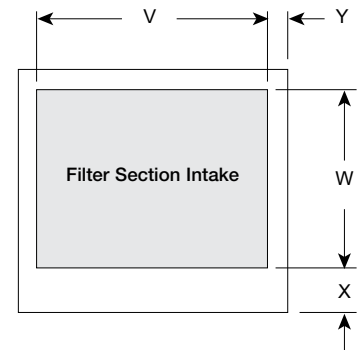
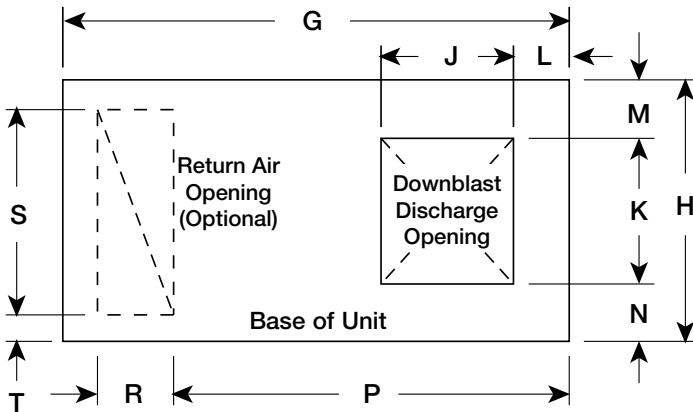

## Model IG Return Air or Downblast Discharge Dimensions

Housing	G		H	J	K	L	M	N	P	R	S	T
	100% Outside Air	Recirculation										
H10	73.1	89.0	43.5	26.5	23.7	2.7	3.9	12.4	73.8	12.9	35.6	2.1
H20	76.2	92.0	52.6	29.5	32.7				76.7		44.6	2.1
H30	85.2	101.0		38.5					85.7			2.1

## Model IG Intake Dimensions

Housing	V	W	X	Y
H10	32.5	30.0	3.8	8.5
H20	41.5			
H30				

All dimensions are shown in inches

## Model IG Approximate Unit Weight (lbs.)

Housing	Total Unit Weight	Total Unit with Evap Cooling	
		Dry Weight	Wet Weight
H10	380	695	936
H20	845	990	1231
H30	1190	1415	1797

\*Unit weights by housing based on largest furnace and motor size available.

# Model IG Roof Curbs

Greenheck provides installation flexibility with multiple roof curb options that meet your needs. Whether for flat or pitched roofs, insulated or non-insulated decks, Greenheck curbs facilitate installation and provide weather tightness when roofed and flashed to the factory-supplied roof curb 2 inch wood nailer. All curbs are manufactured with 18 gauge galvanized steel and may be shipped with or in advance of the equipment. Roof curbs over 120 inches in length (70 inches for GPIP at 24 inches height) may ship knocked down for ease of installation.

Roof Curb Model Options Table for Model IG

		GPI	GPNS	GPS	GPIP
Roof Deck	Flat	x	x	x	
	Pitched				x
	Insulated	x			x
	Non Insulated		x	x	
Curb Construction	Tabbed & Riveted		x		
	Welded	x		x	x
	Curb Height in inches	12, 16, 20, 24	8, 12	8, 12	12, 16, 20, 24

## Model IG Roof Curb Dimensions

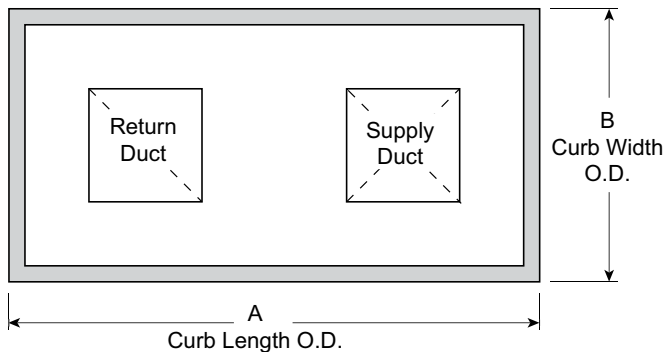

Model IG

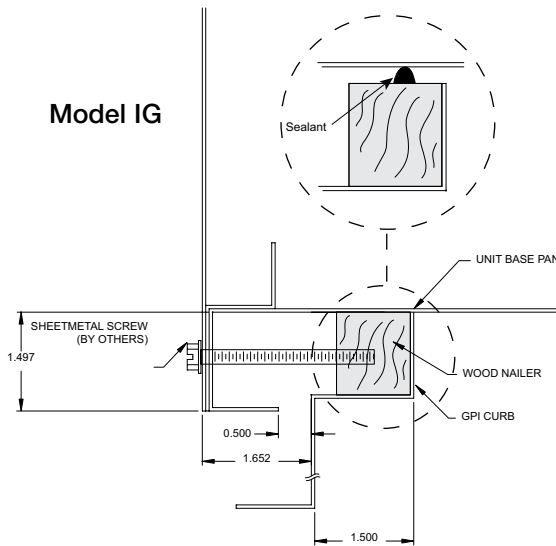

Roof Curb Unit Detail

## Model IG Roof Curb Dimensions

Housing	A		B
	100% Outside Air	Recirculation	
H10	57.5	89.0	40.0
H20	60.5	92.0	49.0
H30	72.5	101.0	

## Model IG Supply Side Roof Curb Dimensions

Housing	C	D	E	F	G	H	J	K
H10	26.44	23.67	30.5	35.5	2.72	2	3.85	12.48
H20	29.44	32.67	33.75	44				
H30	38.44		42	44				

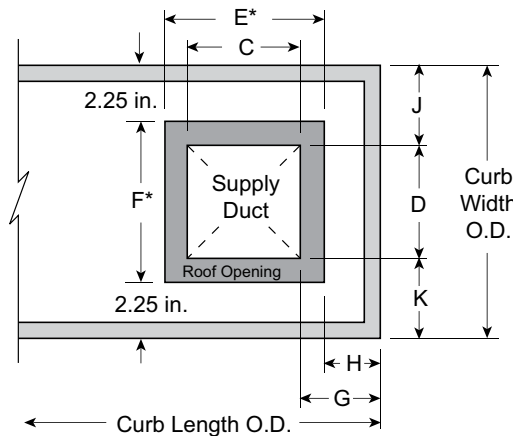

\*Recommended roof openings.

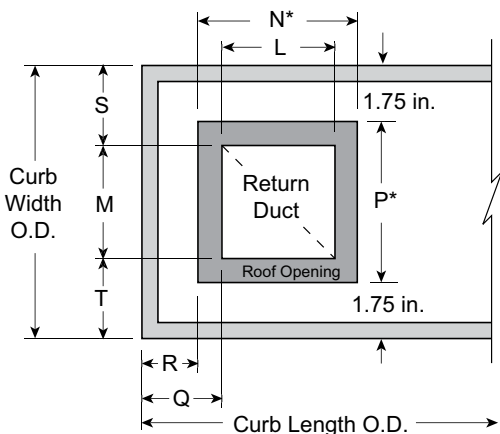

\*Recommended roof openings.

## Model IG Return Side Roof Curb Dimensions

Housing	L	M	N	P	Q	R	S	T
H10	12.89	35.55	17	36.5	2.32	2	2.4	2
H20		44.55		45.5				
H30		44.55						



# Model IG Evaporative Cooling

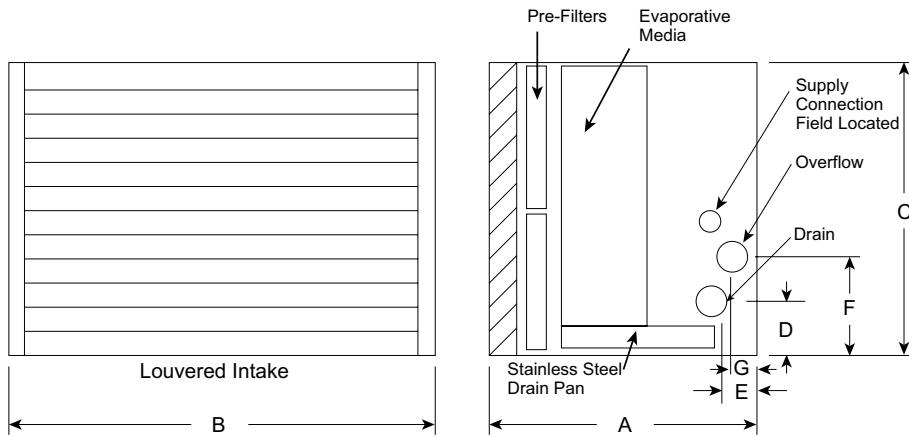

Greenheck's evaporative coolers include a galvanized steel housing with louvered intake, 2 in. aluminum mesh pre-filters, stainless steel evaporative media casing and drain pan. Evaporative cooling media shall be cellulose or fiberglass with a depth of 12 inches for approximate cooling effectiveness of 90%. Supply connection is field located through unit. Drain and overflow connections shall be piped through the side for easy installation. Equipment supports for mounting are optional. See Greenheck's Installation, Operation and Manual for piping guidelines.

## Model IG Evaporative Cooler

Housing	CFM	Total Unit Length with Evap		A	B	C	D	E	F	G	Drain Connection	Overflow Connection	Supply Connection	Filters			Replacement Media	
		100% O.A.	Return Air Unit											Qty	Size	GFC P/N:	Qty	Size
H10	800 to 3,500	109.2	125.8	36.0	52.5	36.0	2.3	6.4	4.0	3.8	0.75	0.75	0.25	4	16x25x2	451763	3	12x12x28.5
																	1	8x12x28.5
																	1	6x12x28.5
H20	800 to 3,500	112.2	128.8	36.0	52.5	36.0	2.3	6.4	4.0	3.8	0.75	0.75	0.25	4	16x25x2	451763	3	12x12x28.5
																	1	8x12x28.5
	3,501 to 7,000	112.2	128.8	36.0	68.6	36.0	2.3	6.4	4.0	3.8	0.75	0.75	0.25	2	16X25X2	451763	5	12X12X28.5
															4	16X20X2	451437	1
H30	2,400 to 3,500	121.2	137.8	36.0	52.5	36.0	2.3	6.4	4.0	3.8	0.75	0.75	0.25	4	16x25x2	451763	3	12x12x28.5
																	1	8x12x28.5
	3,501 to 7,000	121.2	137.8	36.0	68.6	36.0	2.3	6.4	4.0	3.8	0.75	0.75	0.25	2	16X25X2	451763	5	12X12X28.5
															4	16X20X2	451437	1

All dimensions are shown in inches.

## Typical Installation

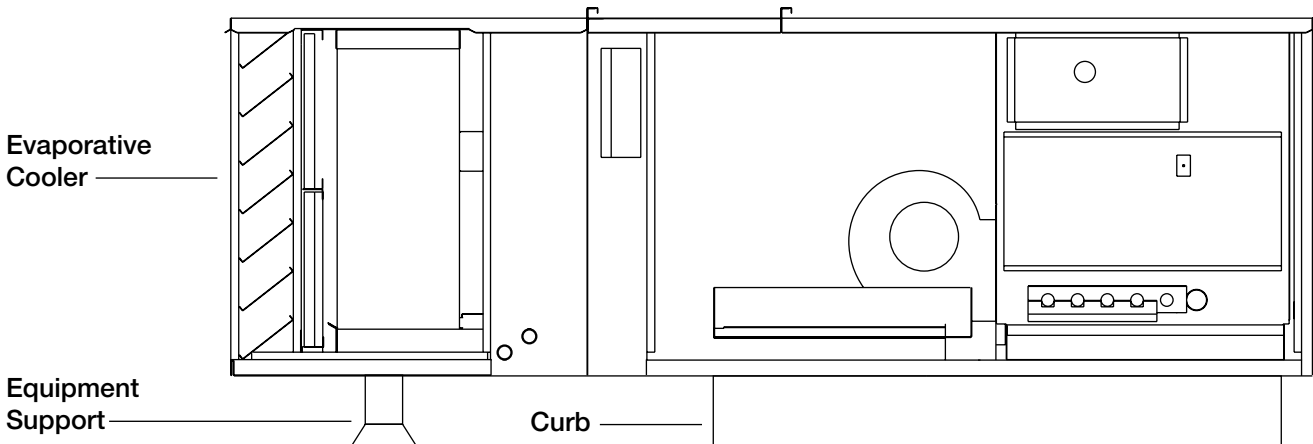

# Model IGX Performance Data

## Air Performance Data & Furnace Availability

Model	Housing	MBH		CFM	RPM/BHP	Total Static Pressure in inches of WG				
		Min.	Max			0.75	1.00	1.25	1.50	1.75
IGX-108	H12	100	150	800	RPM	1109	1216	1311	1399	-
					BHP	0.26	0.31	0.35	0.4	-
				1,200	RPM	1347	1445	1530	-	-
					BHP	0.59	0.68	0.75	-	-
IGX-109	H12	100	250	1,500	RPM	1014	1140	1255	1361	1460
					BHP	0.45	0.54	0.63	0.73	0.84
				2,400	RPM	1244	1329	1419	1503	1587
					BHP	1.2	1.4	1.6	1.7	1.9
IGX-110	H12	100	250	2,000	RPM	0.995	1082	1166	1247	1325
					BHP	0.93	1.1	1.2	1.4	1.5
				3,000	RPM	1202	1275	1340	1401	1464
					BHP	2.0	2.2	2.4	2.6	2.8
IGX-112	H22	150	600	2,600	RPM	761	853	934	1009	-
					BHP	0.72	0.86	1.0	1.2	-
				4,400	RPM	939	1006	1073	1137	1197
					BHP	2.1	2.4	2.6	2.9	3.1
IGX-115	H22	150	600	4,000	RPM	741	808	871	931	986
					BHP	2.0	2.3	2.6	2.9	3.2
IGX-118	H32	300	1,200	7,000	RPM	627	685	738	790	839
					BHP	2.5	2.8	3.2	3.6	4.0
				10,000	RPM	759	805	849	891	933
					BHP	5.5	6.1	6.6	7.1	7.7
IGX-120	H32	300	1,200	10,000	RPM	590	634	678	723	765
					BHP	4.0	4.5	5.0	5.6	6.1
				15,000	RPM	763	795	829	861	892
					BHP	10.9	11.6	12.3	13.1	13.8

Note: The air performance data shown does not include internal static pressure losses due to items such as filters, dampers, cooling and furnaces. For exact air performance data based on specific unit configuration, use the Greenheck CAPS selection program.

## Model IGX Pressure Loss Table

Housing Size	CFM	Housing	Louvered Weatherhood	Aluminum Mesh V-Bank	Inlet Damper	Furnace	Evaporative Cooler
H12	1200	0.12	0.04	0.02	0.01	0.04	0.10
	2500	0.27	0.15	0.07	0.05	0.05	0.43
	3500	0.35	0.30	0.13	0.10	0.07	0.84
H22	3000	0.16	0.08	0.02	0.02	0.04	0.22
	4000	0.28	0.15	0.04	0.04	0.04	0.40
	6000	0.33	0.34	0.09	0.09	0.09	0.90
H32	7000	0.26	0.26	0.03	0.06	0.11	0.42
	10000	0.27	0.53	0.06	0.11	0.23	0.86
	14000	0.54	1.03	0.12	0.22	0.45	1.69

## Model IGX Motor Weights (lbs.)

Hp	¼	½	¾	1	1½	2	2½	3	5	7½	10	15	20	25
Motor Weight	16	20	22	36	42	45	67	69	75	110	115	203	268	350

# Model IGX Unit Dimensions

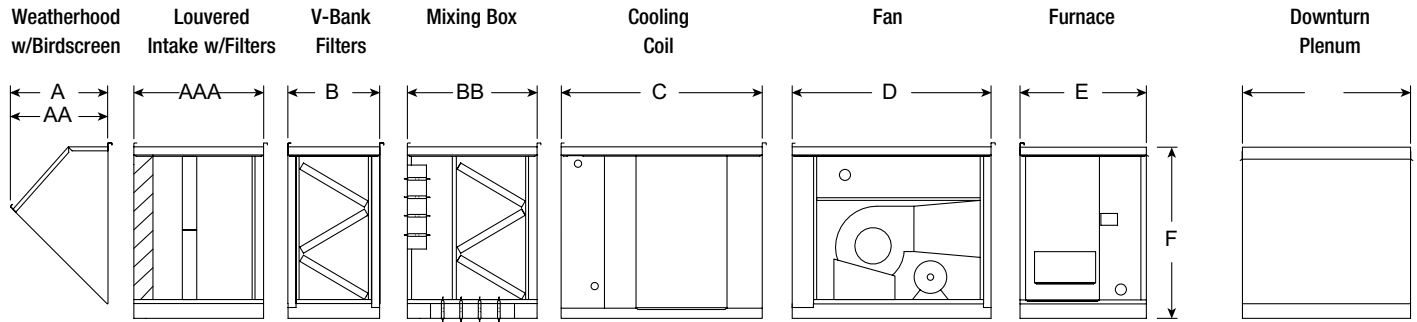

\*AA - Filtered Weatherhood

## Model IGX Unit Dimensions

Housing	A	AA	AAA	B	BB	C		D	Furnace Size	E	F	Downturn* Plenum	Width
						Low	High						
H12	24.8	31.5	13.8	21.5	30.7	30	50.4	42.5	100-250	33.2	39	n/a	44.1
H22	31.5	46.6	16.9	24	34	30	69.4	52.2	150-300	33.2	44.9	n/a	44.6
									350-400				53.9
									500-600	66.4			44.6
H32	47	48.5	16.9	25.8	40.7	98	66	66	350-400	33.2	48.7	n/a	53.1
									500-800				
									1050-1200	99.6			

All dimensions are shown in inches.

## Model IGX Intake Dimensions

Housing	Intake Width	Intake Height	V	W
	T	U		
H12	30.9	34	4.9	1.1
H22	41.7	39.95	4.9	1.1
H32	49.75	43.75	4.9	1.2

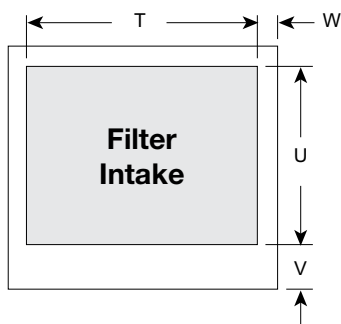

Reference dimension S on page 12 for total width of filter housing

## IGX Horizontal Discharge Dimensions

Housing	Furnace Size	G	H	J	K	L
H12	100	44.1	15	28.6	21.9	1.8
	150		21		15.9	
	200		27		9.9	
	250		32		4.9	
H22	150	53.4	21	28.6	21.8	1.8
	200		27.1		15.8	
	250		31		11.9	
	300	38	4.9			
	350-400	53.4	38	28.7	4.9	
	500	53.4	31	28.6	11.9	
600	38		4.9			
H32	350	52.2	38	39.4	8.7	2
	400		38		8.7	
	500-600		29		17.6	1.8
	700-1200		29		8.7	

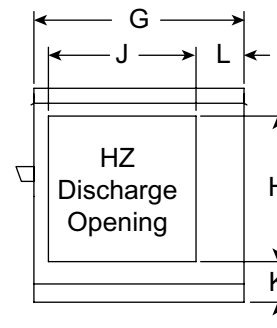

# Model IGX Unit Dimensions

## IGX Mixing Box Dimensions

Housing	N	P	Q	R	S
H12	20	21	4.7	6.1	33.2
H22	22	32	8.7	6.1	44.1
H32	28.3	41.3	9.2	5.5	52.2

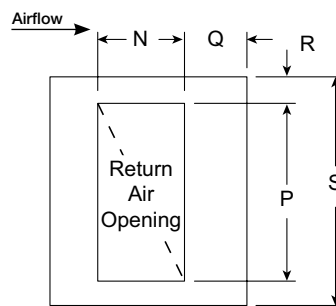

Mixing Box Top View

## IGX Downblast Discharge Dimensions

Housing	Furnace Size	HH	JJ	KK	LL
H12	100-250	25	23	3.9	5.2
H22	150-300	26	25	3.9	5.2
	350-400		34		
	500-600		25		
H32	350-1200	26	34	3.5	5.3

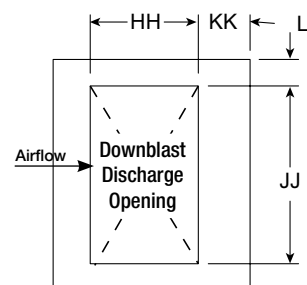

Downblast Discharge Opening

## Model IGX Approximate Unit Weight

Housing	Weatherhood	V-bank Filters	Mixing Box	Cooling Coil		Evap Cooler				Fan Section			Furnace											
				Low CFM	High CFM	Wet	Dry	Blower Max hp	108 3/4	109 3 hp	110 3 hp	MBH	100	150	200	250								
H12	48	83	180	284	327	355	197	Weight	260	316	329	Weight	295	305	313	367								
				Low CFM	High CFM												Low CFM	High CFM	Low CFM	High CFM	Blower Max hp	112 3 hp	115 7 1/2 hp	
H22	68	137	256	488	550	489	546	248	280	Weight	474	560	Weight	304	313	367	382	425	425	734	764			
				Low CFM	High CFM	Low CFM	High CFM	Low CFM	High CFM													Blower Max hp	118 10 hp	120 15 hp
H32	159	185	303	549		640	750	305	330	Weight	803	888	Weight	425	425	734	764	850	850	1275	1275			
				Low CFM	High CFM	Low CFM	High CFM	Blower Max hp	118 10 hp													120 15 hp		MBH

\*Reference Cooling Section on page 14 and 15 to determine high or low cfm cooling coil for H12 to H22 units and evaporative cooler H22 to H32.  
 \*Fan section weight includes maximum motor hp weight. All weights shown in pounds (lbs.)

# Model IGX Roof Curbs

Greenheck provides installation flexibility with multiple roof curb options that meet your needs. Whether for flat or pitched roofs, insulated or non-insulated decks, Greenheck curbs facilitate installation and provide weather tightness when roofed and flashed to the factory supplied roof curb 2 inch wood nailer. All curbs are manufactured with 18 gauge galvanized steel and may be shipped with or in advance of the equipment. Roof curbs over 120 inches in length (70 inches for GPIIP at 24 inches height) may ship knocked down for ease of installation.

Roof Curb Model Options Table for Model IGX

		GPI	GPNS	GPS	GPIIP
Roof Deck	Flat	x	x	x	
	Pitched				x
	Insulated	x			x
	Non Insulated		x	x	
Curb Construction	Tabbed & Riveted		x		
	Welded	x		x	x
	Curb Height in inches	12, 16, 20, 24	8, 12	8, 12	12, 16, 20, 24

# Model IGX Roof Curb Dimensions

IGX-H12, H22, H32

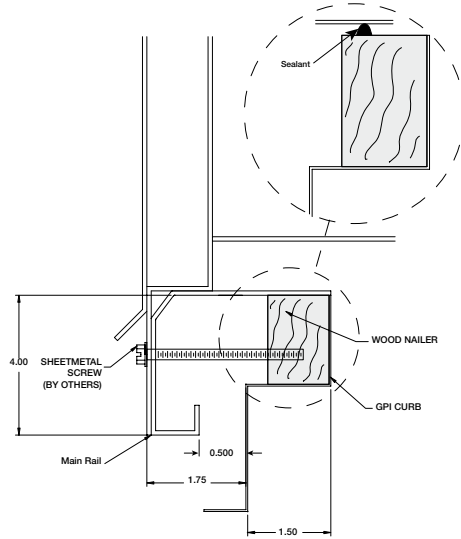
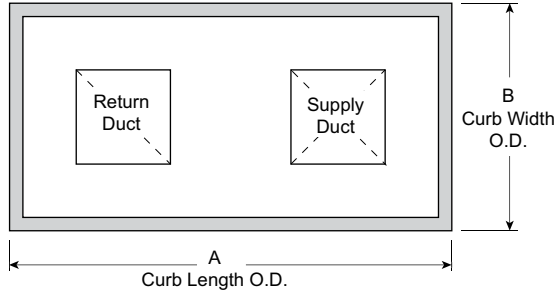

Roof Curb Unit Detail

Housing	A										B
	Furnace Size						Mixing Box	Downturned Plenum	DX or CW Coil		
	<=400	500-600	700	800	1050	1200			Short	Long	
H12	72.75	-	-	-	-	-	+30.75	-	+30	+50.5	29.5
H22	82.5	115.75	-	-	-	-	+34	-	+30	+69.5	40.5
H32	96.25	129.25	129.25	129.25	162.5	162.5	+40.5	-	-	+98	48.5

Housing Size	C	D	E	F	G	H	J	K	L	M
H12	25	23	26	25	2½	¾	¾	2	2¼	2¼
H22 (150-300, 500-600)	26	25	27	36	2½	3	12½	2	2¼	2¼
H22 (350, 400)	26	34	27	36	2½	¾	¾	2	2¼	2¼
H32	26	34	27	44	2½	¾	11	2	2¼	2¼

\*Recommended roof openings.

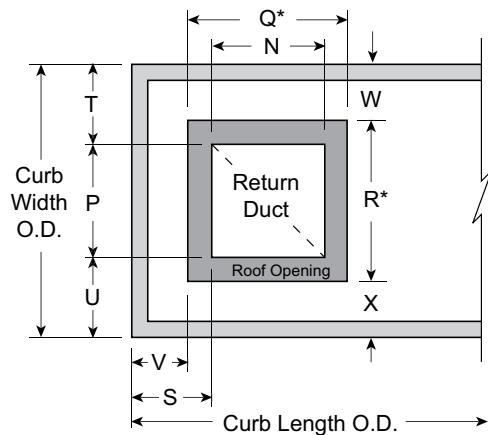
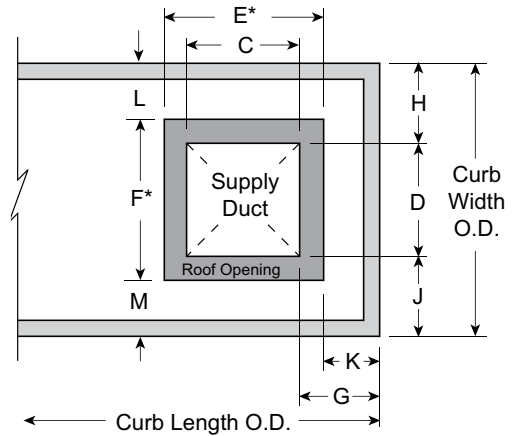

Housing Size	N	P	Q	R	S	T	U	V	W	X
H12	20	21	20¼	25	1⅞	4¼	4¼	1¾	2¼	2¼
H22	22	32	22⅝	36	1⅞	4¼	4¼	1¼	2¼	2¼
H32	28¼	41¼	28½	44	1⅞	3⅝	3⅝	1¼	2¼	2¼

\*Recommended roof openings.

# Model IGX Evaporative Cooling

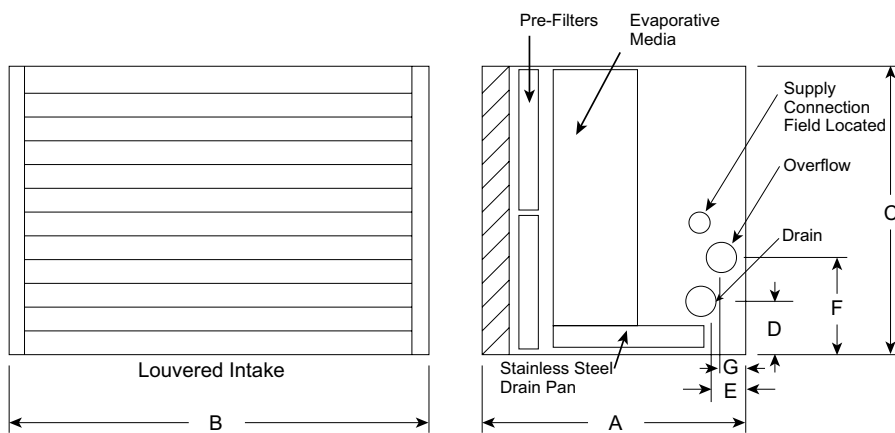

Greenheck's evaporative coolers include a galvanized steel housing with louvered intake, 2 in. aluminum mesh pre-filters, stainless steel evaporative media casing and drain pan. Evaporative cooling media shall be cellulose or fiberglass with a depth of 12 inches for approximate cooling effectiveness of 90%. The evaporative cooler is designed for a maximum airflow velocity of 600 ft/min. Supply connection is field located through unit. Drain and overflow connections shall be piped through the side for easy installation. Equipment supports for mounting are optional. See Greenheck's Installation, Operation and Maintenance Manual for piping guidelines.

## Model IGX Evaporative Cooler

HOUSING	CFM	Dimensional Data							Drain Connection	Overflow Connection	Supply Connection	Filters			Replacement Media	
		A	B	C	D	E	F	G				Qty	Size	GFC P/N:	Qty	Size
H12	800 to 3,000	30.2	33.2	40.0	5.75	1.4	7.4	1.4	0.75	0.75	0.25	4	16x16x2	460640	2	12x12x27.5
												1	6X12x27.5			
H22	2,000 to 4,800	30.2	44.0	46.0	5.75	3.1	7.4	3.1	0.75	0.75	0.25	2	16x20x2	451437	3	12x12x33
												2	20x20x2	451438	1	7.5x12x33
	4,801 to 7,000	34.7	51.5	46.0	5.75	6.8	7.7	6.8	0.75	0.75	0.25	3	12x20x2	451766	5	12x12x33
												3	20x25x2	451439		
H32	4,500 to 9,000	34.7	66.5	48.7	5.75	6.8	7.7	6.8	0.75	0.75	0.38	6	16x20x2	451437	5	12x12x35.75
												2	20x20x2	451438	1	6x12x35.75
	9,001 to 14,000	38.1	96.5	48.7	2.75	11.6	4.7	11.6	0.75	0.75	0.38	6	16x25x2	451763	8	12x12x39
												3	12x25x2	451767		
												2	16x20x2	451437		
1	12x20x2	451766														

All dimensions are shown in inches

## Typical Installation

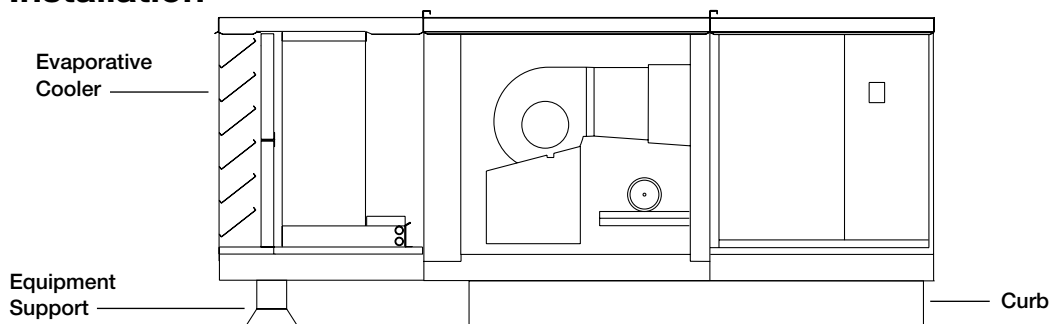

# Model IGX DX and Chilled Water Cooling Coil

- Insulated double-wall construction
- Double-sloped stainless steel drain pan
- Coil and drain connections are stubbed thru side panel for easy hook up
- DX liquid line connections ship internal to unit with access door ensuring damage free delivery
- Cooling controls, thermal expansion valves, condensers and compressors are by others
- Maximum airflow velocity of 525 ft/min.



## IGX Cooling Coil

Housing	CFM	Coil Dimensions (HxL)	A	B	Housing Height	
H12	Low	1,250 to 2,150	27x22	30	33	39
	High	2,151 to 3,400	27x34	50	33	39
H22	Low	2,300 to 3,800	33x33	30	44	45
	High	3,801 to 6,700	33x56	69	44	45
H32	High	5,350 to 11,000	36x85	98	52	48.7

All dimensions are shown in inches

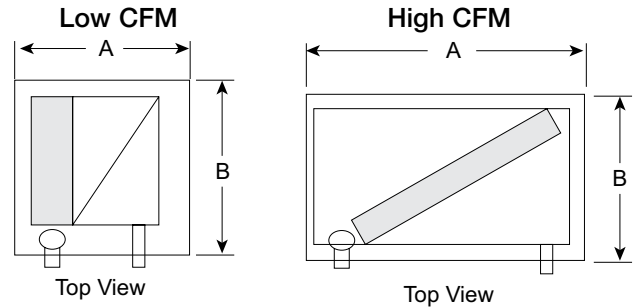

# Furnace Outdoor Venting

Model IG

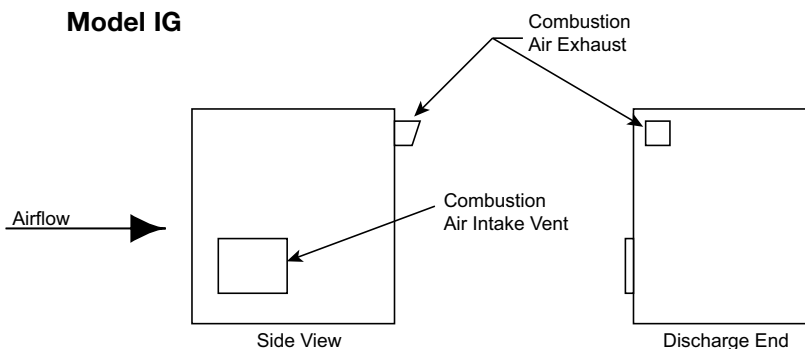

Model IGX

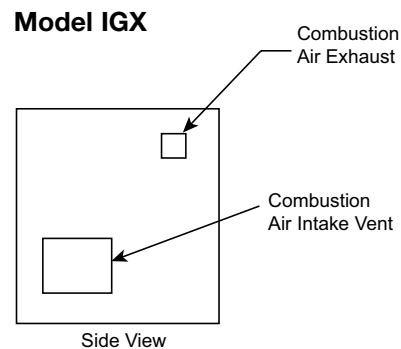

The Greenheck outdoor vent options include a combustion air intake vent and power exhaust vent. An optional combustion exhaust vent terminal is available for installation on a field supplied vertical stack. Check local codes for venting requirements.

Combustion exhaust discharge must be located a minimum of 42 in. from any combustion material. Maintain a minimum of 4 feet clearance from electrical meters, gas meters, regulators, and relief equipment – use minimum 6 feet clearance in Canada.

## Indoor Venting Options

When your application calls for indoor installation, Greenheck offers multiple venting options:

Basic Indoor Venting

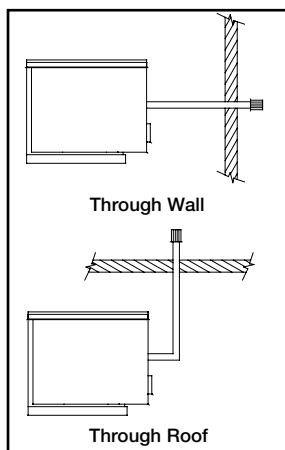

Basic indoor venting uses indoor air for combustion and vents combustion by-products outdoors through a vent line in the wall or roof.

Separate 2-Pipe Venting

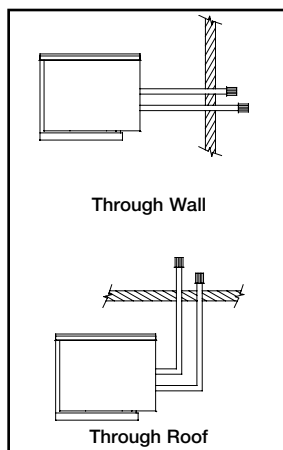

Separate 2-pipe venting uses outdoor combustion air and vents combustion by-products outdoors through a vent line, requiring separate roof or wall openings for each line.

Concentric Venting

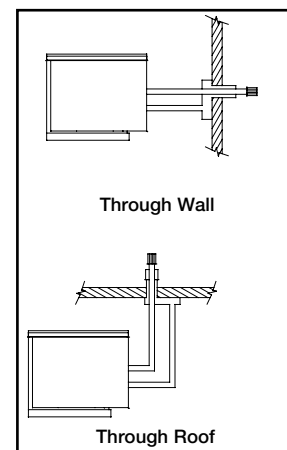

Concentric venting uses outdoor air for combustion and vents combustion by-products outdoors through a vent line, but offers you the benefit of only one roof or wall penetration.

## Concentric Vent Adapter

The concentric vent adapter allows for only one roof penetration for both combustion air intake and exhaust. Vent terminals are included. Exhaust pipe is by others and must be approved for Category III appliance or single-wall, 26 gauge or heavier galvanized pipe vent.

### Concentric Vent Adapter Dimensions

Model	Furnace Size (MBH)	A	B	C	Non-Concentric Side Vent Diameter (inches)		Concentric Side Vent Diameter (inches)	
					Exhaust	Combustion Air	Exhaust	Combustion Air
CVA-4	75 to 175	11	11	6	4	4	4	6
CVA-6	200 to 400	17	10.25	6.25	6	6	6	8

All dimensions are shown in inches

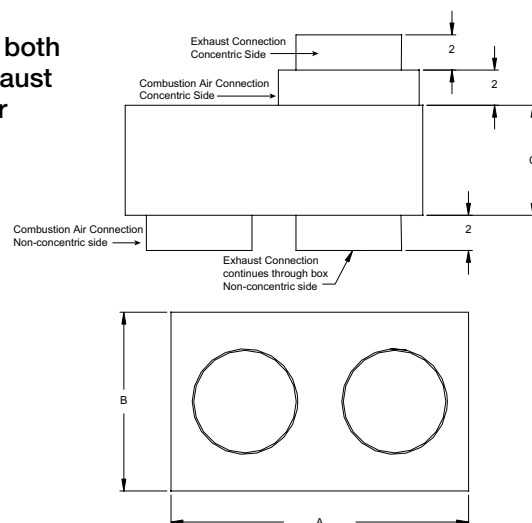



### IG Reference - Venting Connection Location (H10, 20, 30)

Housing	A	B	C	D	E	F	Flue Connection Size (Diameter)				
							Standard		Non-Concentric		Concentric
							Exhaust	Exhaust	Intake	Exhaust	Intake
10	3.89	5.12	9.12	11.59	23.11	27.58	4.0	4.0	4.0	4.0	6.0
20	3.91	3.89	7.89	11.62	25.34	32.27	6.0	6.0	6.0	6.0	8.0
30	3.91	3.89	7.89	11.62	25.34	32.27	6.0	6.0	6.0	6.0	8.0

All dimensions are in inches. Dimensions B and E are not needed for standard venting.  
A round adapter should be used for the exhaust connection.

### Model IG

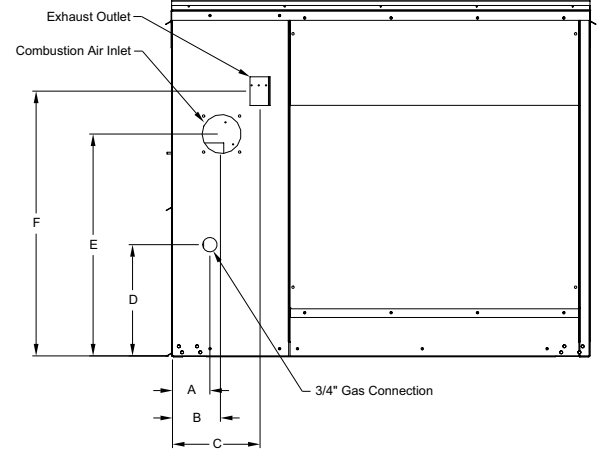

### Model IGX - Venting Connection Location (H12, 22, 32)

Housing	Furnace Size	A	B	E	F	Flue Connection Size (Diameter)				
						Standard		Non-Concentric		Concentric
						Exhaust	Exhaust	Intake	Exhaust	Intake
H12	100-150	4.45	8.45	23.43	27.9	4	4	4	4	6
	200-250	5.64	9.64	23.97	30.9	6	6	6	6	8
H22	150	4.45	8.45	29.38	33.85	4	4	4	4	6
	200-300	5.67	9.67	24.97	31.9	6	6	6	6	8
	350-400			19.01	25.94					
	500-600			24.97	31.9					
H32	350-1200	5.96	9.71	28.31	35.24	6	6	6	6	8

### Model IGX (H12, 22, 32)

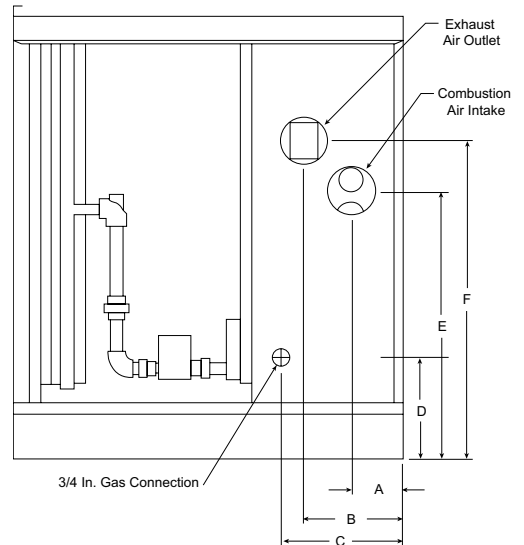

### IGX Gas Connection (H12, 22, 32)

Housing	MBH	C	D
H12	100-250	8.5	8.0
H22	150-600	8.5	8.0
H32	350-1200	8.5	8.0

All dimensions are shown in inches

# Weatherhood Options

Greenheck weatherhoods include 18 gauge galvanized construction with integral galvanized wire mesh inlet screen for outdoor mounting. Filtered weatherhoods feature 2 inch aluminum mesh filters with a slide out design for easy service access for service. Louvered intakes include moisture-eliminating louvers with 2 inch aluminum mesh filters that provide a compact space saving design. All three intake options are designed to prevent water and debris from entering the system.

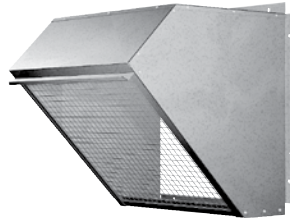

Weatherhood with Birdscreen  
IG & IGX



Louvered Intake  
IG & IGX

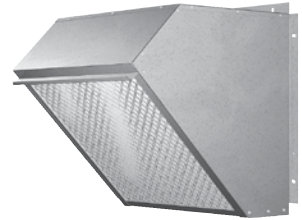

Filtered Weatherhood  
IGX

## Filters

Greenheck offers 2 inch aluminum mesh or pleated disposable filters. Aluminum mesh filters are approximately 5% efficient and are typically applied to most industrial, manufacturing, and kitchen applications. Disposable filters are 30% efficient, include a MERV 7 rating and are applied where a higher degree of cleanliness is required such as schools, nursing homes, packaging, and food processing plants. Please consult the Greenheck factory for high efficiency filtration (up to 95%).

### Disposable Filters

- Die-cut double-wall moisture resistant beverage board frame
- Adhesive bond of frame and media prevent bypass
- High loft blended synthetic and natural fiber media with fire retardant additive
- Galvanized steel support grid
- Face velocity rating of 300 to 625 ft/min.
- 30% average efficiency (ASHRAE 52-76)
- MERV 7 rating (ASHRAE 52.2)
- Arrestment value exceeds 90%
- UL Class 2 Rated per UL Standard 900

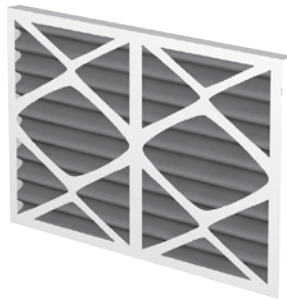

### Aluminum Mesh Filters

- Bonded aluminum media provides strength and durability
- Aluminum media in varying pattern obtains maximum depth loading
- Easily washable
- Delivers high performance at varying velocities up to 650 ft/min.
- Average arrestment of 68% at 520 ft/min. when tested per ASHRAE 52-76
- Meets UL Class 2 requirements



### Model IG

Housing	Filter Type (2 in.)	V-Bank Filters Weatherhood w/Birdscreen			Louvered Intake		
		Qty	Nominal	GFC P/N	Qty	Nominal	GFC P/N
H10	Aluminum Mesh	8	12x20x2	451766	4	16x20x2	451437
	Disposable	8	12x20x2	463685	-	-	-
H20	Aluminum Mesh	8	12x25x2	451767	4	16x25x2	451763
	Disposable	8	12x25x2	456452	-	-	-
H30	Aluminum Mesh	8	12x25x2	451767	4	16x25x2	452915
	Disposable	8	12x25x2	456452	-	-	-



### Model IGX

Housing	Filter Type (2 in.)	*V-Bank Filters Weatherhood w/Birdscreen			Louvered Intake			Filtered Weatherhood		
		Qty	Nominal	GFC P/N	Qty	Nominal	GFC P/N	Qty	Nominal	GFC P/N
H12	Aluminum Mesh	4	15x20x2	458206	4	16x16x2	460640	4	16x20x2	451437
	Disposable	4	15x20x2	458208	-	-	-	-	-	-
H22	Aluminum Mesh	6	20x20x2	451438	4	20x20x2	452916	2	20x25x2	453499
	Disposable	6	20x20x2	451435	-	-	-	4	12x25x2	451767
H32	Aluminum Mesh	10	20x25x2	451439	6	16x25x2	452915	6	20x25x2	453499
	Disposable	10	20x25x2	451436	-	-	-	-	-	-

\*V-bank filters apply to units with Mixing Box or Standard Weatherhood with Birdscreen. All dimensions shown in inches.

# Diffuser Options

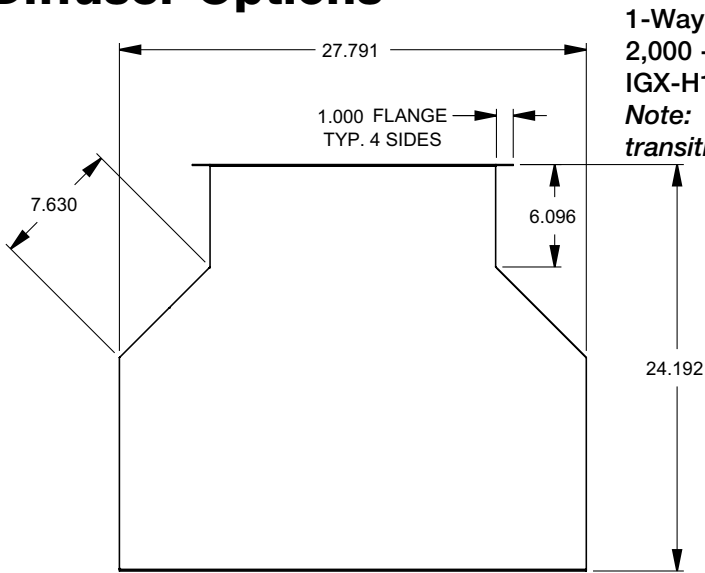

**1-Way Diffuser**  
 2,000 - 4,000 cfm  
 IGX-H12 and H22 Only  
*Note: Diffuser may require duct transition from discharge of unit.*

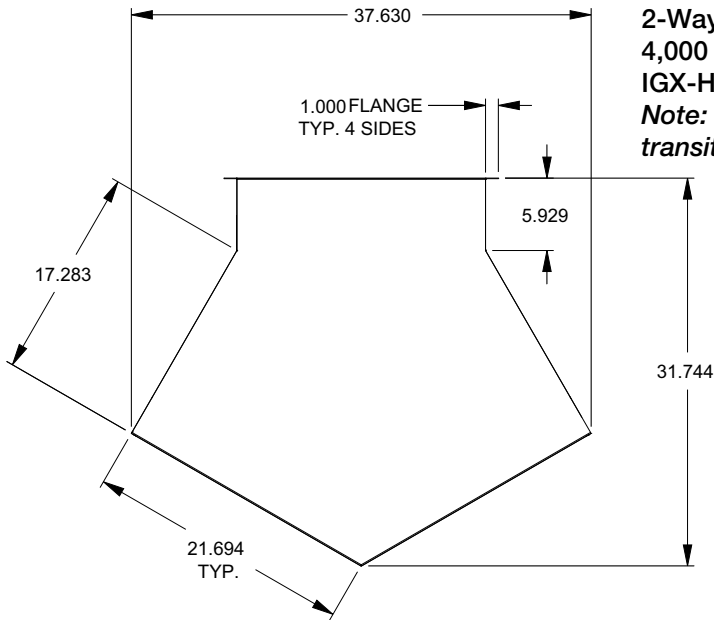
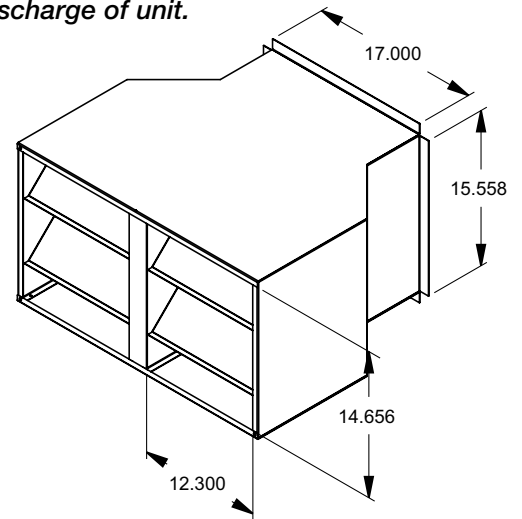

**2-Way Diffuser**  
 4,000 - 6,000 cfm  
 IGX-H12 and H22 Only  
*Note: Diffuser may require duct transition from discharge of unit.*

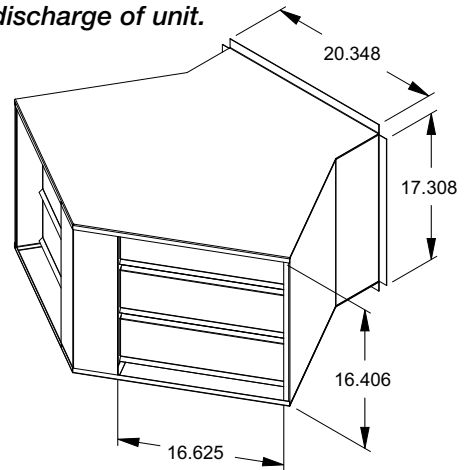

## 4-Way Diffuser

	Blower Size	Maximum CFM	A	B	C	D	E	F	G
IG/IGX	112-115	8,000	41.75	41.75	8.75	32	6	22	18
IGX	118-120	16,000	49.75	49.75	12.75	42.0	10.0	28.00	26.00

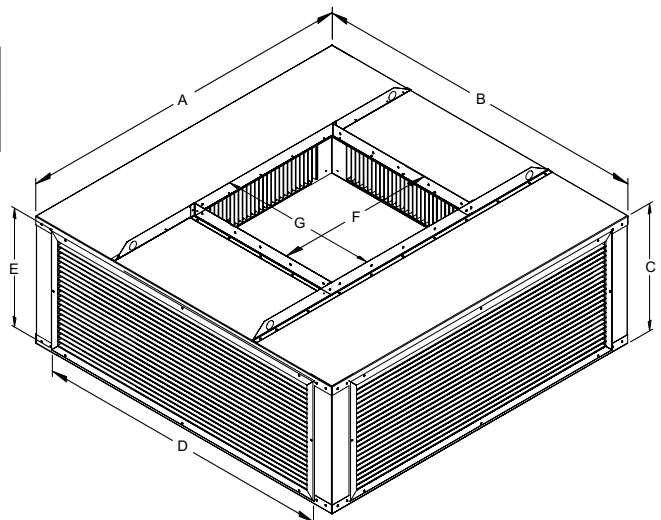

# Make-Up Air Furnace & Temperature Controls

Capable of operating on natural gas or LP vapor, the Greenheck furnace includes power venting, main gas pressure regulator, main gas valve, direct spark ignition system, high limit, 24 V control transformer. Furnace turndown capability is maximized with your choice of electronic staged, electronic modulation, or external supplied 0-10 VDC or 4-20 mA furnace control.

## Electronic Modulation

- Maxitrol 92 Series
  - Single furnace control
  - Up to 400 MBH
  - 55 to 90 discharge temperature range
  - Up to 2:1 modulating turndown per furnace



## Stage Control

- Johnson A350 Series
  - Single, double or triple furnace control
  - Up to 1200 MBH
  - 55 to 90 discharge temperature range
  - Up to 2:1 staged turndown per furnace



- 4:1 Modulating Turndown
  - Single, double, or triple furnace control
  - Up to 1200 MBH
  - 55 to 95 discharge temperature range
  - Up to 4:1 modulating turndown per furnace
  - 8:1 turndown on double furnace, 12:1 turndown on triple furnace

- 8:1 Staged Turndown
  - Single, double, or triple furnace control
  - Up to 1200 MBH
  - 55 to 95 discharge temperature range
  - Up to 8:1 modulating turndown per furnace
  - 16:1 turndown on double furnace, 24:1 turndown on triple furnace

## IG Turndown Ratio Availability

Housing	Modulation Control		Staged Control	
	Maxitrol 92	Johnson FX Controller	Johnson A350	Johnson FX Controller
H10	2:1	4:1	2:1	8:1
H20				
H30				

## IGX Turndown Ratio Availability

Housing	Furnace Size	Modulation Control		Staged Control	
		Maxitrol 92	Johnson FX Controller	Johnson A350	Johnson FX Controller
H12	100 - 250	2:1	4:1	2:1	8:1
H22	150 - 400	2:1	4:1	2:1	8:1
	500 - 600	n/a	8:1	4:1	16:1
H32	350 - 400	2:1	4:1	2:1	8:1
	500 - 800	n/a	8:1	4:1	16:1
	1050 - 1200	n/a	12:1	6:1	24:1

## Room Override

- Space mounted stat increases discharge air temperature by up to 40°F when space temperature is below its set point. Once satisfied, the unit discharge temperature reverts back to the set point on the discharge temperature selector.
- Coiled bimetal element
- Single stage SPST mercury switch
- Setting lever and thermometer scale on thermostat face



- Standard off-white color
- Straight in wiring capability
- Mount directly on wall or vertical panel box
- Dimensions: 4¾ in. high x 2⅞ in wide x 1⅝ in. deep
- CSA certified File No. LR95329-1

## External Signal Furnace Control

- Receives external (4-20mA or 0-10 VDC by others) to modulate furnace.

# Technical Guide: Furnace Control and Turndown Ratio

## Electronic Modulation

The benefit of electronic modulation is that it enables precise LAT (leaving air temperature) control. As outdoor air temperatures vary, the furnace can modulate the gas flow and deliver a constant LAT. The graph below illustrates how this system would react to a start up condition at 20°F.

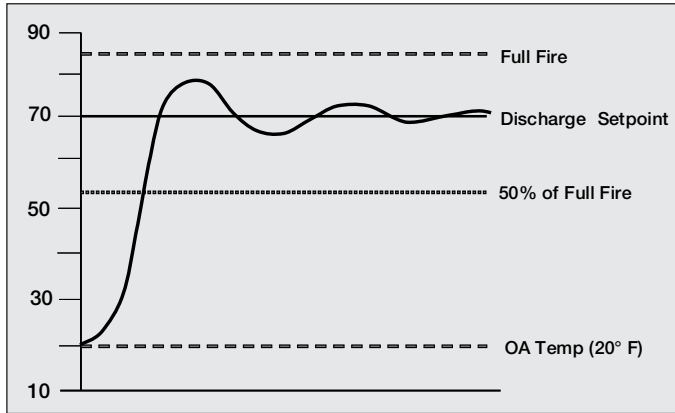

*Operation within electronic modulation range; LAT control of  $\pm 2^\circ\text{F}$*

However, a potential problem exists if the modulation range has a limited turndown. Many manufacturers of indirect gas-fired make-up units only offer electronic modulation with a 2:1 turndown. This can result in the performance illustrated by the graph below with the same system operating at an outdoor temperature of 45°F.

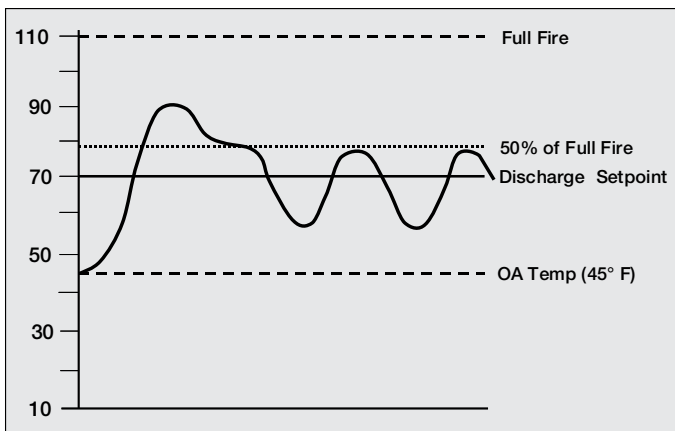

*Operation not within electronic modulation range; LAT control of  $+ 10^\circ\text{F}$*

The key point is that a make-up air unit with electronic modulation only gives you precise temperature control when the furnace operates within its modulation range. Outside of the modulation range, the furnace will behave like a single-stage unit and deliver inconsistent LAT.

Turndown	“Staged” Mode Operation Time	“Modulation” Operation Time
2:1	60%	40%
4:1	20%	80%
8:1	5%	95%

How often the make-up air unit actually runs in its modulation range is dependent on the turndown ratio. Based on weather bin data analysis for a wide range of climates, the table above provides reasonable estimates.

The solution to this potential problem is specifying a higher turndown ratio so that operation in the modulation range is maximized. Greenheck offers the highest modulation turndown ratios in the industry. The table below summarizes Greenheck’s capabilities.

## Electronic Modulation

1 Furnace (Up to 400 MBH)	2 Furnaces (500 to 800 MBH)	3 Furnaces (over 800 MBH)
4:1	8:1	12:1

## Multi-Stage Control

An alternative to electronic modulation furnace control is high turndown multi-stage control. Where maximum turndown ratio is desired, multi-stage control is the answer. A single furnace make-up air unit (< 400 MBH) can have an 8:1 turndown ratio.

As with the electronic modulation options, the multi-stage turndown ratio offering is dependent on the number of furnaces in a make-up air unit. The table below summarizes the staging available from Greenheck.

## Multi-Stage Control

1 Furnace (Up to 400 MBH)	2 Furnaces (500 to 800 MBH)	3 Furnaces (over 800 MBH)
8:1	16:1	24:1

The 8:1 multi-stage system on a single furnace make-up air unit will provide LAT accuracy of  $\pm 3.5^\circ\text{F}$  across the entire range of outdoor air temperature conditions. The 16:1 (2 furnaces) and 24:1 (3 furnaces) systems will typically provide LAT accuracy of  $\pm 2^\circ\text{F}$ .

## Summary

Be sure that the turndown ratio or number of stages is clearly called out in your specification. A spec that simply states “shall have electronic modulation control” will likely result in a 2:1 turndown ratio, resulting in unsatisfactory LAT control and unhappy customers.

MODEL IG DATA  
 MODEL IGX DATA  
 FURNACE VENTING  
 FILTERS DIFFUSERS  
 MAKE-UP AIR CONTROLS  
 H & V CONTROLS  
 TYPICAL SPECIFICATIONS

# Make-Up Air Airflow & Evaporative Cooling Controls

## Mixing Box

For buildings that experience varying demands in fresh air requirements, Greenheck mixing box and variable volume control options provide the solution that minimize energy consumption while meeting fresh air requirements. All airflow controls are low voltage and easily interface with building management systems. Greenheck mixing boxes include low leakage control dampers for outdoor and return air with a control actuator in a face and bypass configuration. Either 2-inch pleated 30% efficient filters or 2-inch aluminum mesh filters are available. Filters are positioned so that the return air is also filtered. A moisture eliminating louvered intake is available for outdoor mounted units.

**Two position:** Includes outdoor air and return air dampers with 2-position actuator. Unit provides either 100% outdoor air or 100% return air. Responds to user input from 2-position return air ON/OFF switch on factory supplied TSCP remote control panel. With return air on, the dampers are positioned 100% return air, 0% outdoor air. With return air off, the dampers are positioned for 100% outdoor air.

**Building Pressure Control:** Outdoor air and return air dampers with modulating actuator modulate to maintain desired building pressure through a photohelic gauge that compares indoor air and outdoor air pressure. As exhaust air volumes vary, the dampers will modulate via the photohelic gauge to maintain the desired building pressure setting that is adjustable on the photohelic gauge. A slight positive pressure is a normal setting. Standard photohelic gauge offers a range of -0.25 in. wg to +0.25 in. wg

**Potentiometer:** Dampers with modulating actuator are controlled by a remote mounted potentiometer on a factory supplied TSCP remote control panel. As the potentiometer is adjusted, the position of the dampers is varied to provide anywhere from 100% outdoor air to 100% return air. Outside air and return air combine to provide the supply air.



**External Signal by others:** Providing the ultimate in flexibility to meet customer control demands, the supply and return air dampers with modulating actuator are controlled by customer supplied 4-20 mA or 2-10 VDC signal. As the supplied signal varies, the damper position modulates. Actuator is factory-wired to numbered control terminal block for easy field wiring

**Occupied/Unoccupied for Model IGX Only:** Dampers with 2-position actuator modulate based on mode set point. When in occupied mode, dampers modulate to provide 100% outdoor air and blower runs continuously with furnace modulating based on discharge temperature controller. When in unoccupied mode, dampers modulate to provide 100% return air with the blower cycling on and off based on a call for heat from a factory supplied space thermostat. The Occupied/Unoccupied mode is determined by a programmed setting on the factory supplied 7-day programmable time clock mounted in TSCP remote control panel or a 2-position manual switch.

## Variable Volume

**Two Speed:** A variable frequency drive (VFD) controls the motor to one of two discrete speeds. The VFD enables the unit to run at either maximum airflow or reduced speed. The motor speed control is achieved through a Low/Off/High speed switch mounted on the TSCP remote control panel.

**Variable Frequency Drive:** A variable frequency drive controls the motor speed based on output from a potentiometer or a building pressure controller - photohelic gauge. The photohelic gauge will compare indoor and outdoor air pressure. As exhaust volumes vary, the make-up air volumes are adjusted to maintain the desired building pressure. The manual potentiometer can be adjusted to vary air volumes from approximately 50% to 100% airflow.



## Evap Cooling Control Option

**Recirc:** Factory-supplied water pump recirculates water over media with constant bleed off to prevent mineral build-up. Float valve included.

**Recirc with Auto Drain & Flush:** The drain and flush cycle timer changes water in the sump based on programmed cycle time to reduce or prevent mineral build-up. Includes freeze protection to drain sump and all water lines if outdoor air temperature drops below freeze stat set point. Freeze stat, cycle timer, pumps and float valve, are included.



**Water Wizard:** Measures outdoor air temperature and humidity and adjusts water supplied to media to maximize evaporative cooling. On cool or humid days, the Wizard knows the evaporative cooling potential is low and reduces the water supply to save you money. On hot or dry days, the Wizard increases the water supply rate to meet the increased evaporative cooling potential and provide the most cooling possible. Factory provided controller includes LED display and easy user interface keys. Temperature sensors, pressure gauge and manual supply valve are included.



# Industrial Make-Up Air Temperature Control Recommendation Manual Heating Switch

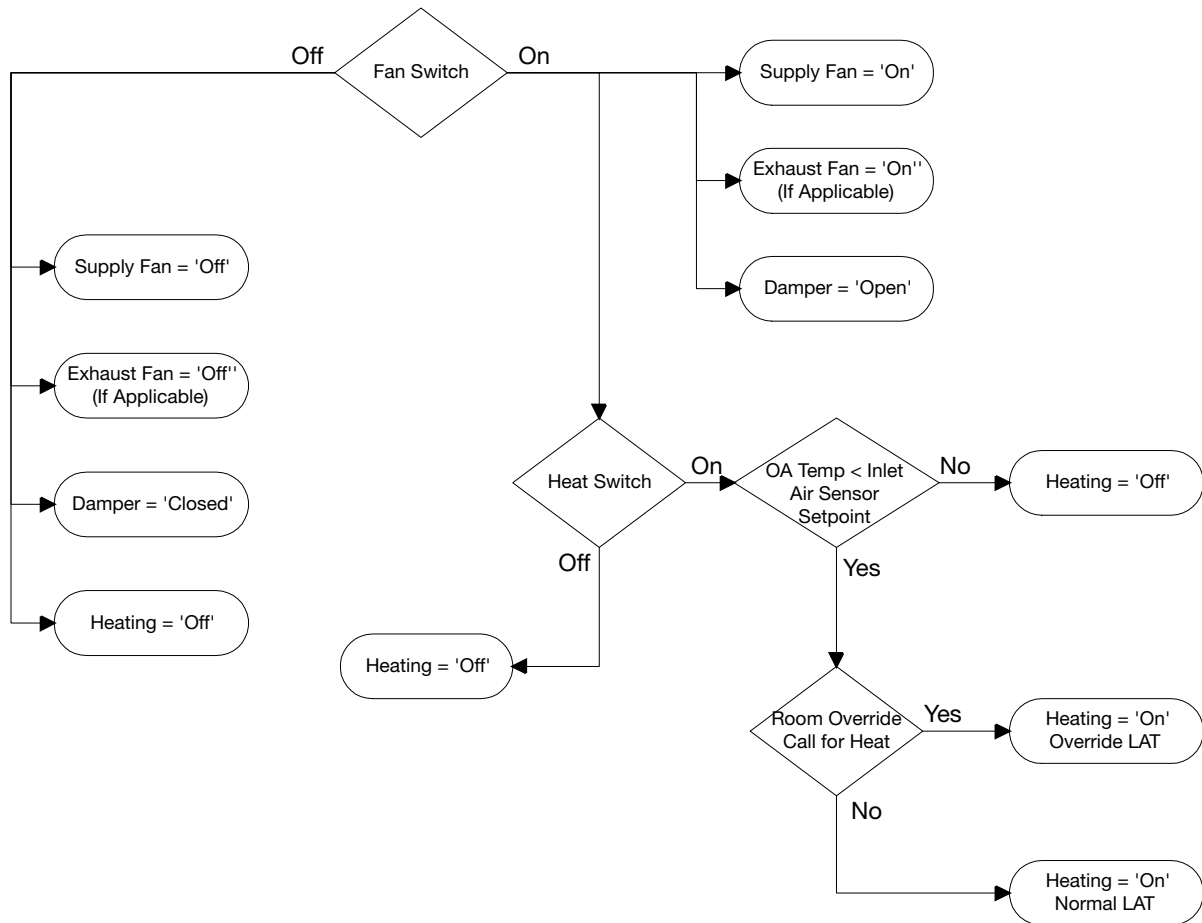

**Application:** This make-up air control system is recommended for industrial make-up air systems. A fan switch energizes the make-up air fan and opens the damper. If an exhaust fan is interlocked with the make-up air unit (exhaust starter provided by Greenheck and mounted in the make-up air unit control center), the exhaust fan will also be energized. A separate manual switch energizes the heater. This system enables the user to manually control the fan and heater operation. A heat/cool switch may be substituted for the heat switch.

**Heating Set Point(s):** Like most make-up air systems, this discharge temperature control system will adjust the heating capacity to satisfy the LAT (Leaving Air Temperature) set point. In Normal mode, the heater will heat the air to the Normal LAT set point when the outdoor air temperature is below the Inlet Air sensor set point. When the room temperature drops below the room set point, the system goes into override mode and the heater will then discharge at the Override LAT set point.

### Typical Temperature Settings for Industrial Make-Up Air Systems:

Normal LAT:	70°F	
Override LAT:	95°F	All set points are field adjustable
Room Temperature:	65°F	
Inlet Air Sensor:	60°F	

**Benefits:** This is a very reliable and economical system that provides industrial facilities with heated make-up air when outdoor temperatures are below 60°F (with Inlet Air Sensor option). The manual fan and heater switches gives the owner the flexibility to choose which mode of operation is desired based on individual circumstances. If the Room Override option is selected, the Room Temperature set point can be adjusted from the remote control panel.

# Greenheck TSCP Industrial Type Remote Control Panel

The Greenheck TSCP industrial type remote control panels feature a variety of unit control switching and indicating lights. The TSCP housing is constructed of 18 gauge galvaneal steel with piano hinge and Permator™ finish. If optional room override is specified with your TSCP, it will be supplied factory mounted on the exterior front panel door. Installation and field wiring is easy with point-to-point wiring between the make-up air unit and TSCP matching numbered terminal blocks.

NEMA 1 rating is standard. Consult factory for NEMA 12 or NEMA 4 options.

**TSCP Dimensions**

	A	B	C
Standard TSCP	12.375	12.375	4.5
TSCP with Building Pressure Control Option	18.375	12.5	7.875

All dimensions are shown in inches

**1 Supply Switch**

Included on all IG and IGX TSCP's. Switch turns supply blower on or off.

**2 Heat / Off / Cool Switch**

Heat switch is included on all IG and IGX TSCP's. Cool position is included if unit is equipped with cooling. Allows user to select tempering from available options.

**3 Additional Switching**

Additional switch is included for two position mixing box control or occupied/unoccupied controls.

**4 Potentiometer**

A potentiometer is included on the TSCP if a manual potentiometer was selected to control a VFD or mixing box. Allows the user to manually adjust the mixing box dampers or VFD speed.

**4 Room Override**

A room override sensor and selector is included on the TSCP if the room override option was selected.

**5 Blower Light**

Included on all IG and IGX TSCP's. Indicates when the supply blower is energized.

**6 Heat Light**

Included on all IG and IGX TSCP's. Indicates when the heat switch is closed.

**7 Cool Light**

Included on all IG and IGX TSCP's equipped with evaporative cooling. Indicates when the cooling switch is closed.

**8 Dirty Filter Light**

Included on all IG and IGX TSCP's equipped with a dirty filter switch. Indicates when pressure drop through filters is greater than set point.

**9 Photohelic Gauge**

Included on all IG and IGX TSCP's equipped building pressurization control of a VFD or mixing box. Includes building pressure gauge and field adjustable set points.

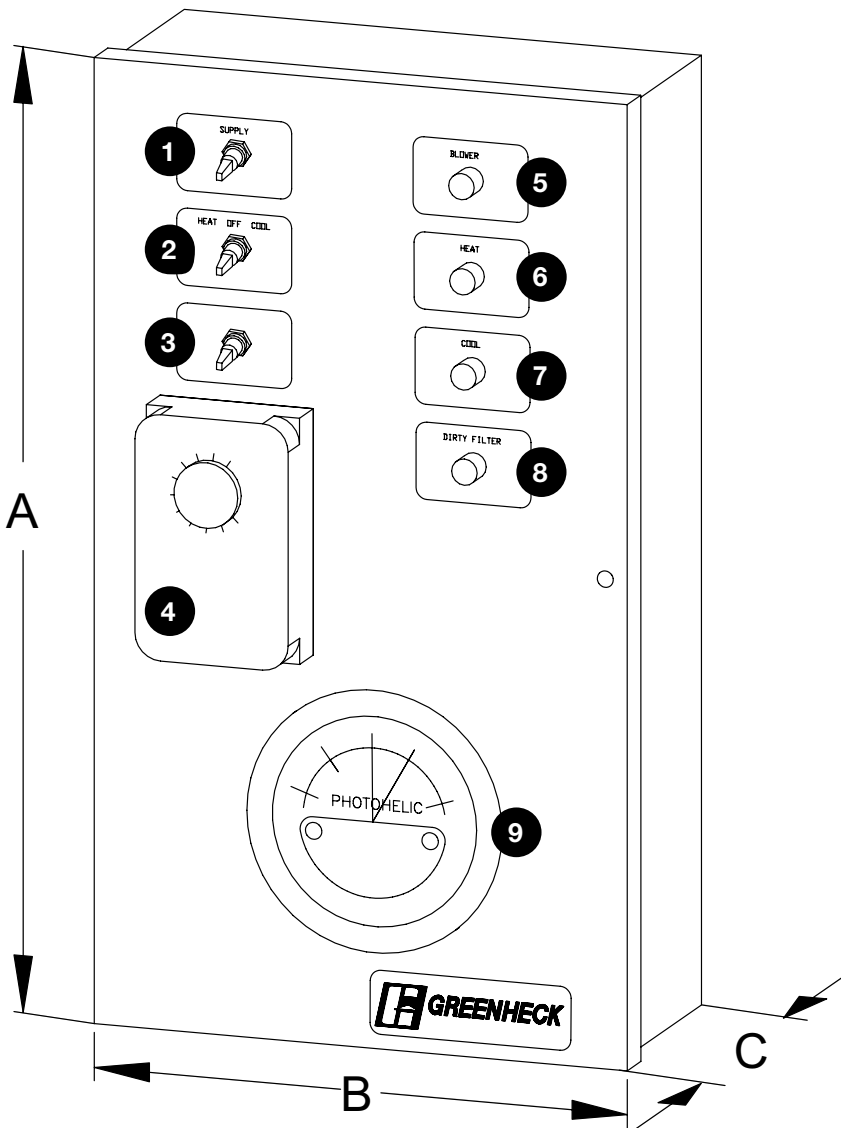



# Commercial Kitchen Make-Up Air Temperature Control Recommendation Automatic Heating

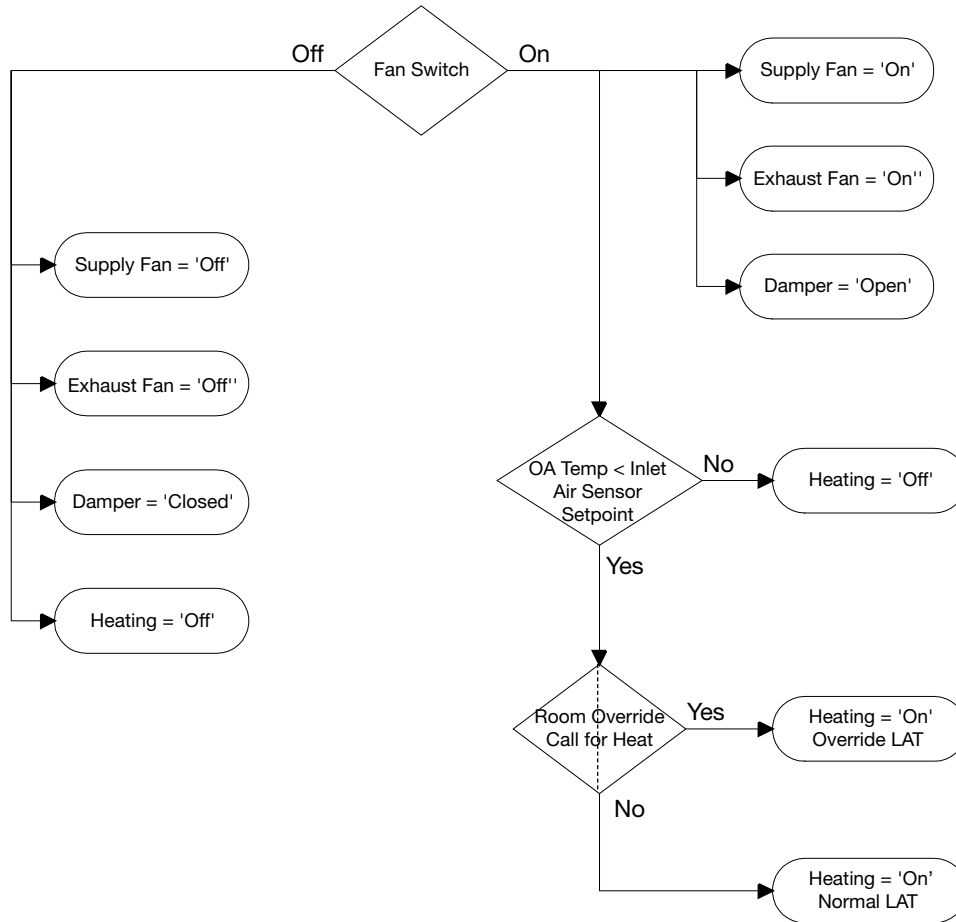

**Application:** This make-up air control system is recommended for commercial kitchen ventilation systems. A single switch energizes the make-up air unit, the exhaust fan and potentially the kitchen hood lights. This ensures that the entire system is operational when the power is switched on. For heating only make-up air systems, this control option provides excellent temperature control that is very economical and very easy to operate.

**Heating Set Point(s):** Like most make-up air systems, this discharge temperature control system will adjust the heating capacity to satisfy the LAT (Leaving Air Temperature) set point. In Normal mode, the heater will heat the air to the Normal LAT set point when the outdoor air temperature is below the Inlet Air sensor set point. If the room temperature drops below the room set point, the system goes into override mode and the heater will then discharge at the Override LAT set point.

**Typical Temperature Settings for Commercial Kitchen Systems:**

- Normal LAT: 60°F
- Override LAT: 95°F All set points are field adjustable
- Room Temperature: 70°F
- Inlet Air Sensor: 55°F

**Benefits:** This system will normally provide cool 60°F air to the kitchen, which is typically very warm due to the cooking process. In cases where the cooking equipment is not generating enough heat to maintain the desired 70°F room temperature, the make-up air unit will bump it's discharge temperature to 95°F until the room temperature reaches 70°F. This system will not allow air to enter the building below the inlet air sensor temperature.

# Make-Up Air Controls

## Kitchen Supply Control Panel (KSCP)

Offers optional hood light, fan, and tempering on/off switches with remote mounted junction box and stainless steel cover plate. Switch labeling is included.

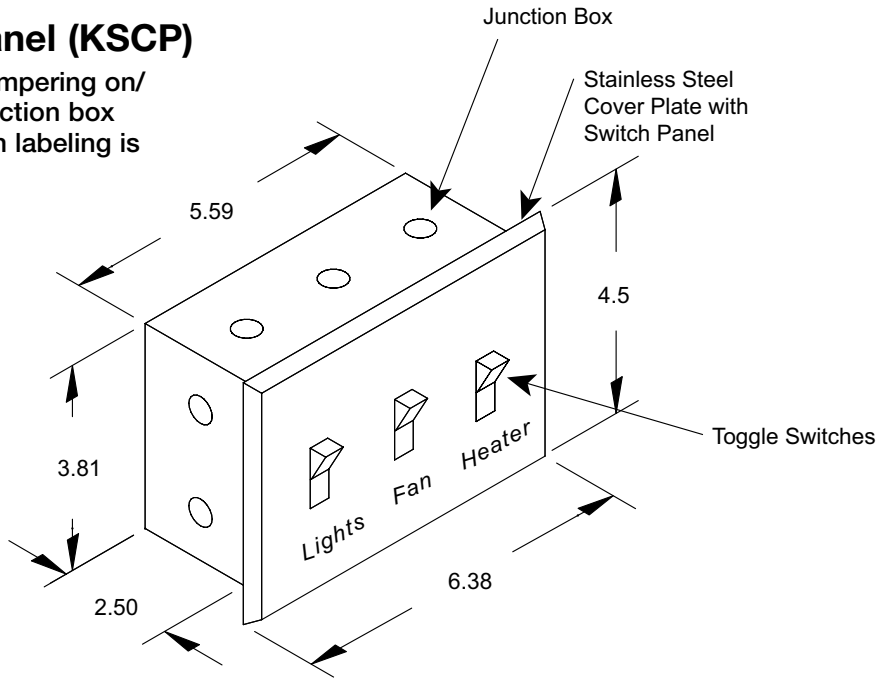

## Typical Wiring of Light/Fan/Heat KSCP

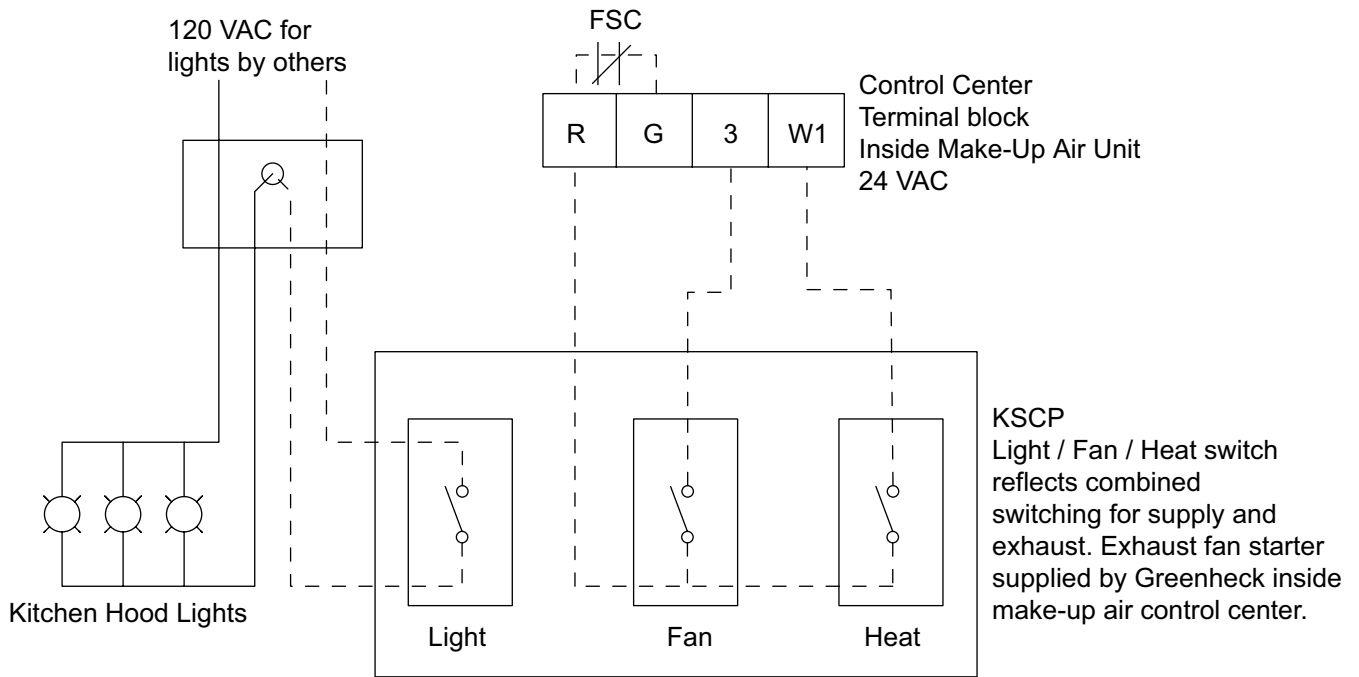



# Heating & Ventilating Controls

## Mixing Box

A filtered mixing box is standard on all heating and ventilating units (HV) and includes outdoor air and return air low leakage control dampers in a face and bypass configuration.

A heating and ventilation (HV) option and a mixing box (MB) or economizer (EC) control option must be specified for every HV unit. Choose one of three heating and ventilation options and one of eight economizer and mixing box options to provide a heating and ventilating solution for your application.

## Heating & Ventilation Options

Choose one of three ventilating options described below. The ventilation option should be chosen based on your application's minimum outside air requirements.

### HV1: 0-30% Minimum Outdoor Air

HV1 is the most common among heating and ventilating units, allowing you to set the minimum outdoor air volume between 0 and 30% of the total supply air volume. With the relatively low percentage of outdoor air, mixed air temperatures are mild and stable. *1-stage heating and/or cooling is recommended (2-stage is optional).*

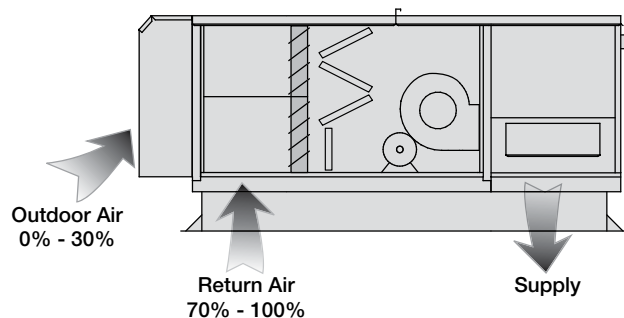

### HV2: 30-75% Minimum Outdoor Air

The HV2 option is required when the minimum outdoor air volume exceeds 30% of the total supply air volume. With higher outdoor air volumes, mixed air temperatures can vary greatly. *Accordingly, 2-stage heating is required.*

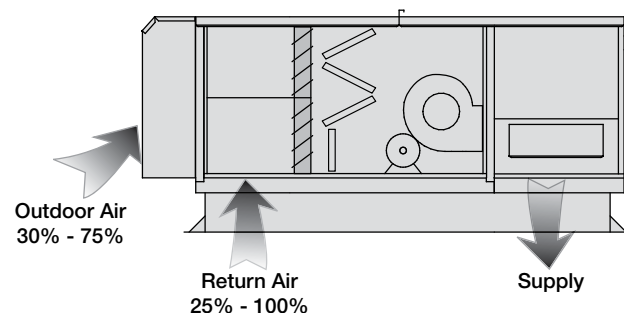

### HV3: 100% Return Air

The HV3 option is available when no outdoor air is needed. With relatively stable return air conditions, *1-stage heating is strongly recommended.*

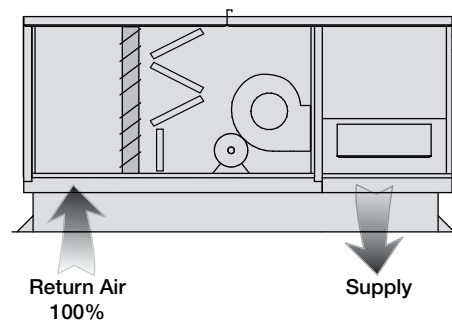

# Heating & Ventilating Controls

## Mixing Box Controls with Economizer Cooling

The economizer control package enables free cooling using outdoor air. All EC options include a modulating actuator for controlling outdoor and return air dampers, and a field adjustable minimum outdoor air positioner. During a call for heating the economizer is locked out and the outdoor air damper holds at the minimum position.

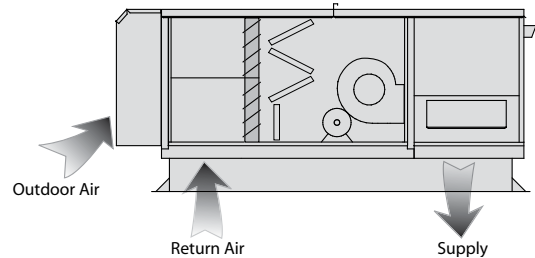

### EC1: Outdoor Temperature Reference

On a call for cooling, option EC1 compares the outside air temperature to the economizer's field adjustable set point.

- If the outside air temperature exceeds the set point, the minimum outside air is provided.
- If the outside air temperature is between the economizer set point and 55°F, the dampers go to the 100% outside air position.
- If the outside air is below 55°F, the dampers modulate to achieve 55°F mixed air temperature.

### EC3: Airstream Temperature Reference

On a call for cooling, economizer option EC3 compares the outdoor and return air temperatures.

- If the outdoor air temperature is greater than the return air, the dampers go to minimum outside air position.
- If the outside air temperature is less than the return air, the dampers will modulate to achieve a 55°F mixed air temperature.

### EC2: Outdoor Enthalpy Reference

On a call for cooling, economizer option EC2 compares the outside enthalpy to the field adjustable enthalpy changeover set point.

- If the outside enthalpy is less than the set point, the dampers will modulate to a 55°F mixed air temperature.
- If the outside air enthalpy is greater than the economizer's set point, the dampers go to the minimum outside air position.

### EC4: Airstream Enthalpy Reference

On a call for cooling, economizer option EC4 compares the outdoor and return air enthalpies.

- If the outdoor air enthalpy is greater than the return air, the dampers go to the minimum outside air position.
- If the outside enthalpy is less than the return air, the dampers will modulate to achieve a 55°F mixed air temperature.

## Mixing Box Controls (no economizer)

In addition to the economizer (EC) options described above, Greenheck offers four mixing box (MB) control options for applications where a factory provided economizer package is not desired.

### MB1: Minimum Outdoor Air Positioner

Mixing box option MB1 includes a modulating actuator and potentiometer that control the outdoor air and return air damper positions. When the unit is energized, the dampers will travel to the position corresponding to the potentiometer setting. The potentiometer is easily adjustable, allowing you to dial in the optimum amount of outdoor air. When the unit is powered off, the outdoor air damper closes to prevent backdrafting.



### MB2: 2-10 Volt External Signal

Mixing box option MB2 includes a modulating actuator controlled by an external 2-10 volt signal. This option is appropriate for applications that call for a building automation system that will control the mixing box dampers.

### MB3: 4-20 mA External Signal

Mixing box option MB3 includes a modulating actuator that is controlled by an external 4-20 mA signal. Like option MB2, this option is appropriate for applications that call for a building automation system to control the mixing box dampers.

### MB4: Manual Quadrant

Mixing box option MB4 uses a manual quadrant to secure the outdoor and return air in the desired position. The damper remains in the secured position and maintains the minimum outside air requirements.



# Heating & Ventilating Controls

## Thermostat Options

Basic bimetal thermostats with mercury switches or fully programmable electronic thermostats are available as part of your HV system. Match your heating, staging, and operational requirements to the appropriate thermostat.

### TC1: 1-stage heating / cooling

TC1 is a coiled bimetal thermostat used for single-stage heating systems. It is also compatible with economizer cooling.



### TC2: 2-stage heating

TC2 is a coiled bimetal thermostat used for 2-stage heating systems.



### TC3: 2-stage heating / cooling

TC3 is a coiled bimetal thermostat used for 2-stage heating and is also compatible with economizer cooling. It includes an adjustable heat anticipator, stops, and a locking cover.



### TC4: Programmable

TC4 has full seven-day program capability. The thermostat can be set to four times and eight temperature settings for each day of the week. It can also control up to two stages of heating and economizer cooling.



### TC5: Deluxe Programmable

TC5 has full seven-day program capability. The thermostat can be set for two occupied and two unoccupied times with adjustable temperature settings for each day of the week. It can control up to three stages of heating and economizer cooling. The Intelligent Fan™ feature energizes the fan continuously during occupied mode and intermittently with a call for heating in unoccupied mode.



## HV Selection Guide

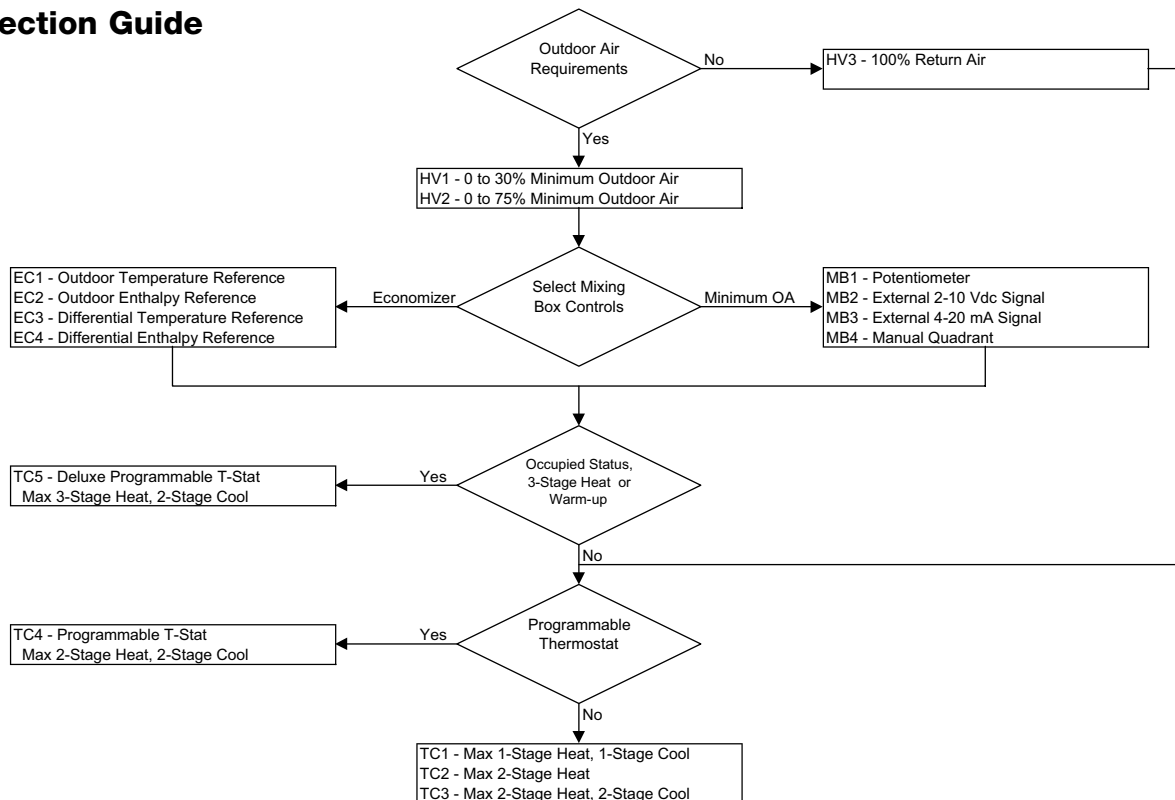



## IG Typical Specification

**General:** Make-up air unit shall be as manufactured by Greenheck Fan Corporation or approved equal provided all specifications are met. Greenheck model IG is used as the basis of design. Performance shall be as scheduled on plans.

**Furnace:** Indirect gas-fired furnace shall be 80% efficient, ETL Listed and have a blow-through fan design. Furnace shall be capable of operation with natural or LP gas and have a power venting system. The heat exchanger shall be constructed of aluminized steel or stainless steel. Standard furnace features shall include main gas pressure regulator, main gas valve, electronic staged or electronic modulating controls, direct spark ignition system, high limit and a 24 volt control transformer.

**Temperature Control:** Furnace heat output shall be controlled based on a field adjustable discharge temperature set point. Discharge temperature sensor shall be factory-mounted and wired to the unit control center. Furnace shall have electronic modulation or electronic staged control.

**Unit Casing and Frames:** Unit shall be of internal frame type construction of galvanized steel. All frames and panels shall be G90 galvanized steel. Where top panels are joined, there shall be a standing seam to ensure positive weather protection. All metal-to-metal surfaces exposed to the weather shall be sealed. All components shall be easily accessible through removable doors.

**Insulation:** Units equipped with a mixing box shall be insulated from the mixing box intake through to the supply discharge. 100% outside air units shall be insulated from the filter section intake through to the supply discharge. Insulation shall be in accordance with NFPA 90A and tested to meet UL 181 erosion requirements. Double-wall construction is standard.

**Fan Section:** Centrifugal fans shall be double-width, double-inlet. Fan and motor shall be mounted on a common base and shall be internally isolated. All blower wheels shall be statically and dynamically balanced. Ground and polished steel fan shafts shall be mounted in permanently lubricated ball bearings. Bearings shall be selected for a minimum  $L_{10}$  life in excess of 100,000 hours at maximum cataloged speeds.

**Filter Section:** Filters shall be mounted in a V-bank arrangement such that velocities across the filters do not exceed 550 ft/min. Filters shall be easily accessible through a removable access panel.

**Weatherhood:** Weatherhood shall be constructed of G90 galvanized steel with birdscreen mounted at the intake.

**Motors and Drives:** Motors shall be energy efficient, complying with EPACT standards, for single speed ODP and TE enclosures. Motors shall be permanently lubricated, heavy-duty type, matched to the fan load and furnished at the specified voltage, phase and enclosure. Drives shall be sized for a minimum of 150% of driven horsepower. Pulleys shall be cast and have machined surfaces, 10 horsepower and less shall be supplied with an adjustable drive pulley.

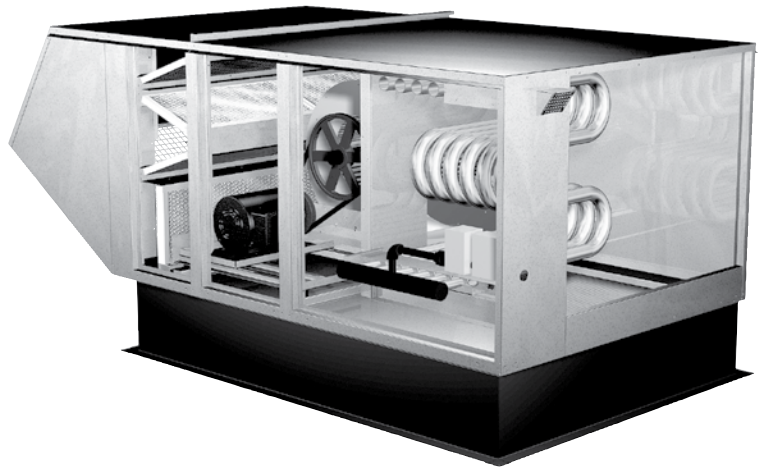

**Electrical:** All internal electrical components shall be prewired for single point power connection. All electrical components shall be UL Listed, Recognized or Classified where applicable and wired in compliance with the National Electrical Code. Control center shall include motor starter, control circuit short circuit protection, control transformer for 24 VAC circuit, integral disconnect switch and terminal strip. Contactors, Class 20 adjustable overload protection and single phase protection shall be standard.

**Mixing Box (2-Position):** Damper shall be either fully open or fully closed. Damper position shall be controlled by a remotely mounted switch. Mixing box shall provide 100% make-up air when the damper is closed and recirculate 100% return air when the damper is open.

**Mixing Box (Building Pressure):** Mixing box shall modulate outdoor and return air volumes to maintain desired building pressure. A remote control panel shall be provided by the make-up air unit manufacturer and include a photohelic gauge. Furnace shall be multi-stage or modulating and operate based on discharge temperature control.

**Mixing Box (Potentiometer):** Mixing box shall enable manual modulation of outdoor and return air volumes from a remote potentiometer. The potentiometer shall be mounted on a control panel provided by the make-up air manufacturer. Furnace shall be multi-stage or modulating and operate based on discharge temperature control.

**Mixing Box (External Signal):** Mixing box shall enable modulation of outdoor and return air volumes from external signal 4-20 mA or 0-10 VDC signal supplied by others. Damper actuator control will be factory-wired to terminal block in unit control center to receive modulation signal field wired to unit by others for easy BMS/DDC interface.

**Evaporative Cooling Section:** Evaporative cooling section shall include a galvanized steel housing with louvered intake, 2 inch aluminum mesh filters and a stainless steel evaporative cooling module all provided by the make-up air unit manufacturer. Evaporative cooling media shall be cellulose or fiberglass with a depth of 12 inches for a cooling effectiveness of 90%. Drain and overflow connections shall be piped through the side of the evaporative cooling section.



# IGX Typical Specification

**General:** Make-up air unit shall be as manufactured by Greenheck Fan Corporation or approved equal provided all specifications are met. Greenheck Model IGX is used as the basis of design. Performance shall be as scheduled on plans.

**Furnace:** Indirect gas-fired furnace shall be 80% efficient, ETL Listed and have a blow-through fan design. Furnace shall be capable of operation with natural or LP gas and have a power venting system. The heat exchanger shall be constructed of aluminized steel or stainless steel. Standard furnace features shall include main gas pressure regulator, main gas valve, electronic staged or electronic modulating controls, direct spark ignition system, high limit and a 24 volt control transformer. Furnace shall be insulated and have double-wall construction.

**Temperature Control:** Furnace heat output shall be controlled based on a field adjustable discharge temperature set point. Discharge temperature sensor shall be factory mounted and wired to the unit control center. Furnace(s) shall have electronic modulation or at least 2 stages of control.

**Unit Casing and Frames:** Unit shall be of internal frame type construction of galvanized steel. All frames and panels shall be G90 galvanized steel. Where top panels are joined, there shall be a standing seam to ensure positive weather protection. All metal-to-metal surfaces exposed to the weather shall be sealed, requiring no caulking at jobsite. All components shall be easily accessible through removable doors.

**Insulation:** Models provided with a mixing box shall be insulated from the return section through to the supply discharge. Insulation shall be in accordance with NFPA 90A and tested to meet UL 181 erosion requirements. Double-wall shall be provided if specified.

**Fan Section:** Centrifugal fans shall be double-width, double-inlet. Fan and motor shall be mounted on a common base and shall be internally isolated. All blower wheels shall be statically and dynamically balanced. Ground and polished steel fan shafts shall be mounted in permanently lubricated ball bearings (up to size 118) or ball bearing pillow blocks (size 120). Bearings shall be selected for a minimum  $L_{10}$  life in excess of 100,000 hours at maximum cataloged speeds.

**Motors and Drives:** Motors shall be energy efficient, complying with EPACT standards, for single speed ODP and TE enclosures. Motors shall be permanently lubricated, heavy-duty type, matched to the fan load and furnished at the specified voltage, phase and enclosure. Drives shall be sized for a minimum of 150% of driven horsepower. Pulleys shall be cast and have machined surfaces, 10 horsepower and less shall be supplied with an adjustable drive pulley.

**Electrical:** All internal electrical components shall be prewired for single point power connection. All electrical components shall be UL Listed, Recognized or Classified where applicable and wired in compliance with the National Electrical Code. Control center shall include motor starter, control circuit short circuit protection, control transformer for 24 VAC circuit, integral disconnect switch and terminal strip. Contactors, Class 20 adjustable overload protection and single phase protection shall be standard.

**Filter Section:** Filters shall be mounted in a V-bank arrangement such that velocities across the filters do not exceed 550 ft/min. Filters shall be easily accessible through a removable access panel.

**Weatherhood:** Weatherhood shall be constructed of G90 galvanized steel with birdscreen mounted at the intake.

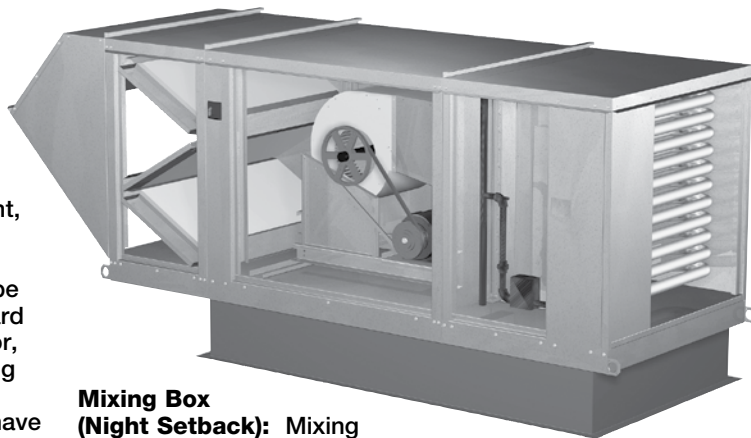

## Mixing Box

**(Night Setback):** Mixing box shall provide 100% make-up air during occupied hours and 100% recirculation air during unoccupied hours. Furnace(s) shall be multi-stage and operate based on discharge temperature control on occupied setting and space temperature control on unoccupied setting. The system shall allow for separate field adjustable temperature set points for occupied and unoccupied modes of operation.

**Mixing Box (2-Position):** Damper shall be either fully open or fully closed. Damper position shall be controlled by a remotely mounted switch. Mixing box shall provide 100% make-up air when the damper is closed and recirculate 100% return air when the damper is open.

**Mixing Box (Building Pressure):** Mixing box shall modulate outdoor and return air volumes to maintain desired building pressure. A remote control panel shall be provided by the make-up air unit manufacturer and include a photohelic gauge. Furnace(s) shall be multi-stage and operate based on discharge temperature control.

**Mixing Box (Potentiometer):** Mixing box shall enable manual modulation of outdoor air and return air volumes from a remote potentiometer. The potentiometer shall be mounted on a control panel provided by the make-up air unit manufacturer. Furnace(s) shall be multi-stage and operate based on discharge temperature control.

**Mixing Box (Building Pressure):** Mixing box shall modulate outdoor and return air volumes to maintain desired building pressure. A remote control panel shall be provided by the make-up air unit manufacturer and include a photohelic gauge. Furnace shall be multi-stage or modulating and operate based on discharge temperature control.

**Mixing Box (External Signal):** Mixing box shall enable modulation of outdoor and return air volumes from external signal 4-20 mA or 0-10 VDC signal supplied by others. Damper actuator control will be factory wired to terminal block in unit control center to receive modulation signal field wired to unit by others for easy BMS/DDC interface.

**Cooling Coil:** Direct expansion (DX) or chilled water coil shall be factory tested and rated in accordance with AHRI 410. Coils shall have copper tubes with permanently expanded aluminum fins, 12 fins per inch or less. DX coils shall be equipped with distributors to receive expansion valves at the liquid connections. Drain pans shall extend at least 12 inches downstream of coil and sloped to drain connection.

**Evaporative Cooling Section:** Evaporative cooling section shall include a galvanized steel housing with louvered intake, 2 inch aluminum mesh filters and a stainless steel evaporative cooling module all provided by the make-up air unit manufacturer. Evaporative cooling media shall be cellulose or fiberglass with a depth of 12 inches for a cooling effectiveness of 90%. Drain and overflow connections shall be piped through the side of the evaporative cooling section.

## IG-HV Typical Specification

**General:** Heating and ventilating unit shall be as manufactured by Greenheck Fan Corporation or approved equal provided all specifications are met. Greenheck Model IG-HV is used as the basis of design. Performance shall be as scheduled on plans.

**Furnace:** Indirect gas fired furnace shall be 80% efficient, ETL Listed and have a blow-through fan design. Furnace shall be capable of operation with natural or LP gas and have a power venting system with post purge cycle. The heat exchanger shall be constructed of aluminized steel or stainless steel. Standard furnace features shall include main gas pressure regulator, main gas valve, electronic staged controls, direct spark ignition system, high limit and a 24 volt control transformer. Furnace shall be insulated and have double-wall construction.

**Temperature Control:** Heating and cooling output shall be controlled by a room thermostat to maintain desired room temperature. Economizer control shall provide the first stage of cooling, where specified. Furnaces shall provide 1 or 2 stages of heat output control.

**Unit Casing and Frames:** All frames and panels shall be G90 galvanized steel. Where top panels are joined, there shall be a standing seam to ensure positive weather protection. All metal-to-metal surfaces exposed to the weather shall be sealed, requiring no caulking at jobsite. All components shall be easily accessible through removable doors.

Unit shall have double-wall construction and be insulated from the mixing box intake through to the supply discharge. Insulation shall be in accordance with NFPA 96 and tested to meet UL 181 erosion requirements.

**Intake:** The intake shall be louvered with aluminum mesh filters.

**Motors and Drives:** Motors shall be energy efficient, complying with EPACT standards, for single speed ODP and TE enclosures. Motors shall be permanently lubricated, heavy-duty type, matched to the fan load and furnished at the specified voltage, phase and enclosure. Drives shall be sized for a minimum of 150% of driven horsepower. Pulleys shall be cast and have machined surfaces, 10 horsepower and less shall be supplied with an adjustable drive pulley.



**Fan Section:** Centrifugal fans shall be double-width, double-inlet. Fan and motor shall be mounted on a common base and shall be internally isolated. All blower wheels shall be statically and dynamically balanced. Ground and polished steel fan shafts shall be mounted in permanently lubricated ball bearings (up to size 118) or ball bearing pillow blocks (size 120 and larger). Bearings shall be selected for a minimum L<sub>10</sub> life in excess of 100,000 hours at maximum cataloged speeds.

**Electrical:** All internal electrical components shall be prewired for single point power connection. All electrical components shall be UL Listed, Recognized or Classified where applicable and wired in compliance with the National Electrical Code. Control center shall include motor starter, control circuit short circuit protection, control transformer for 24 VAC circuit, integral disconnect switch and terminal strip. Contactors, Class 20 adjustable overload protection and single-phase protection shall be standard.

# IGX-HV Typical Specification

**General:** Heating and ventilating unit shall be as manufactured by Greenheck Fan Corporation or approved equal provided all specifications are met. Greenheck Model IGX-HV is used as the basis of design. Performance shall be as scheduled on plans.

**Furnace:** Indirect gas-fired furnace shall be 80% efficient, ETL Listed and have a blow-through fan design. Furnace shall be capable of operation with natural or LP gas and have a power venting system with post purge cycle. The heat exchanger shall be constructed of aluminized steel or stainless steel. Standard furnace features shall include main gas pressure regulator, main gas valve, electronic staged controls, direct spark ignition system, high limit and a 24 volt control transformer. Furnace shall be insulated and have double-wall construction.

**Temperature Control:** Heating and cooling output shall be controlled by a room thermostat to maintain desired room temperature. Economizer control shall provide the first stage of cooling, where specified. Furnaces shall provide 1 or 2 stages of heat output control.

**Unit Casing and Frames:** All frames and panels shall be G90 galvanized steel. Where top panels are joined, there shall be a standing seam to ensure positive weather protection. All metal-to-metal surfaces exposed to the weather shall be sealed, requiring no caulking at jobsite. All components shall be easily accessible through removable doors.

**Insulation:** Models provided with a mixing box shall be insulated from the return section through to the supply discharge. Insulation shall be in accordance with NFPA 90A and tested to meet UL 181 erosion requirements. Double-wall shall be provided if specified.

**Fan Section:** Centrifugal fans shall be double-width, double-inlet. Fan and motor shall be mounted on a common base and shall be internally isolated. All blower wheels shall be statically and dynamically balanced. Ground and polished steel fan shafts shall be mounted in permanently lubricated ball bearings (up to size 118) or ball bearing pillow blocks (size 120 and larger). Bearings shall be selected for a minimum  $L_{10}$  life in excess of 100,000 hours at maximum cataloged speeds.

**Motors and Drives:** Motors shall be energy efficient, complying with EPACT standards, for single speed ODP and TE enclosures.

Motors shall be permanently lubricated, heavy-duty type, matched to the fan load and furnished at the specified voltage, phase and enclosure. Drives shall be sized for a minimum of 150% of driven horsepower. Pulleys shall be cast and have machined surfaces, 10 horsepower and less shall be supplied with an adjustable drive pulley.

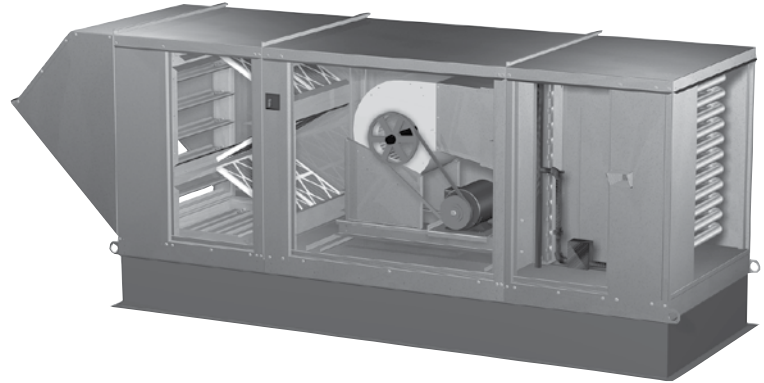

**Electrical:** All internal electrical components shall be prewired for single point power connection. All electrical components shall be UL Listed, Recognized or Classified where applicable and wired in compliance with the National Electrical Code. Control center shall include motor starter, control circuit short circuit protection, control transformer for 24 VAC circuit, integral disconnect switch and terminal strip. Contactors, Class 20 adjustable overload protection and single phase protection shall be standard.

**Filter Section:** Filters shall be mounted in a V-bank arrangement such that velocities across the filters do not exceed 550 ft/min. Filters shall be easily accessible through a removable access panel.

**Weatherhood:** Weatherhood shall be constructed of G90 galvanized steel, with stationary louvered intake with 2 inch aluminum mesh filters.

**Mixing Box:** Mixing box shall contain outside air and return air dampers with low leak, pressure activated, extruded vinyl blade seals, stainless steel jamb seals, Belimo actuator and 30% efficient pleated filters in a V-bank arrangement. The mixing box shall modulate the amount of outdoor and return air by use of dampers. Input signal for return damper shall be from potentiometer, 2-10 volt signal, 4-20 mA signal or manual quadrant controller, or economizer.

**Cooling Coil:** Direct expansion (DX) or chilled water coil shall be factory tested and rated in accordance with AHRI 410. Coils shall have copper tubes with permanently expanded aluminum fins, 12 fins per inch or less. DX coils shall be equipped with distributors to receive expansion valves at the liquid connections. Drain pans shall extend at least 12 inches downstream of coil and be sloped to drain connection.

Heating Type	Model	Airflow Range (CFM)	Max Heater Size (MBH)		Airflow Options		Max Cooling Volume (CFM)		
			Natural Gas	LP	VAV/2-Speed	Recirculation	Evaporative	DX	Chilled Water
Direct Gas	DG	800 - 15,000	1,600	1,400			12,000		
	DGK	1,000 - 8,500	800	700					
	DGX	800 - 48,000	4,800	4,200	■	■	46,000	11,000	11,000
	TSU	30,000 - 64,000	7,000	6,000	■	■	60,000		
	VSU	800 - 64,000	7,000	6,000	■	■			
Indirect Gas	IG	800 - 7,000	400 (input)			■	7,000		
	IGK	1,500 - 5,000	400 (input)						
	IGX	800 - 15,000	1,200 (input)		■	■	19,000	11,000	11,000
	IG-HV	800 - 7,000	400 (input)			■			
	IGX-HV	800 - 15,000	1,200 (input)			■	14,000	11,000	11,000
Steam	MSX	800 - 48,000	1,900 MBH		■	■	46,000	11,000	11,000
Hot Water	MSX	800 - 48,000	1,600 MBH		■	■	46,000	11,000	11,000
Electric	MSX	800 - 48,000	180 kW		■	■	46,000	11,000	11,000
Untempered	KSFD	400 - 2,100							
	KSFB	1,000 - 10,500			■				
	KSF	800 - 12,000			■				
	MSX	800 - 48,000			■	■			
	TSF	30,000 - 64,000			■				

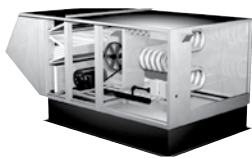

Model IG

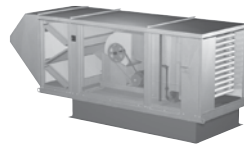

Model IGX

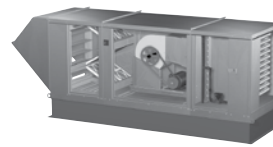

Model IGX-HV

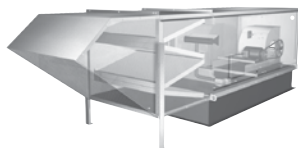

Model DG

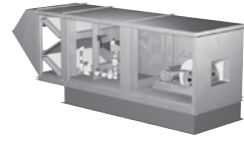

Model DGX

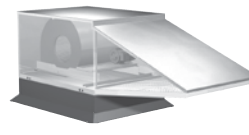

Model KSFD

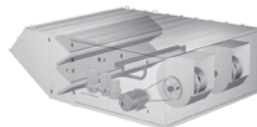

Model TSU

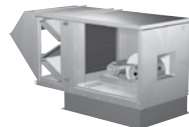

Model MSX

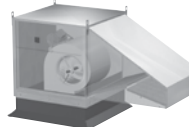

Model KSF



Model VSU

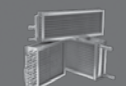
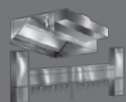
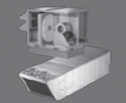
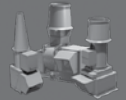

## Our Warranty

Greenheck warrants this equipment to be free from defects in material and workmanship for a period of one year from the shipment date. Any units or parts which prove defective during the warranty period will be replaced at our option when returned to our factory, transportation prepaid. Motors are warranted by the motor manufacturer for a period of one year. Should motors furnished by Greenheck prove defective during this period, they should be returned to the nearest authorized motor service station. Greenheck will not be responsible for any removal or installation costs.

*As a result of our commitment to continuous improvement, Greenheck reserves the right to change specifications without notice.*



Prepared to Support  
Green Building Efforts