

Industrial Process Fans Model IP

Radial Material Handling Wheels



BUILDING VALUE IN AIR.



March
2021

Industrial Duty Centrifugal Fans

Greenheck's radial wheel industrial process centrifugal fans are designed to provide reliable operation for a full range of applications from industrial process ventilation to material handling. Our products are manufactured with state-of-the-art laser, forming, spinning and welding equipment and endure quality control testing to ensure a trouble-free start-up. The latest computer aided design techniques were used to develop critical components. Finite Element Analysis (FEA), for instance, ensures maximum wheel strength and reliability.

Typical Applications

Greenheck's industrial products are specified to transfer or exhaust a variety of materials and for applications including:

- Dust
- Fibrous materials
- Granular materials
- Paper trimmings
- Fumes
- High temperatures
- High pressure applications



Standard with Greenheck Industrial Products:

- AMCA Air Certified Ratings Seal
- Concentric mount bearings
- Corrosion resistant, electrostatically applied baked powder coatings
- Both belt and direct drive configurations
- Three plane, six channel vibration analysis on all manufactured centrifugal models



AMCA Certified Air Performance is found in Greenheck's Computer Aided Product Selection Program (CAPS®).

Manufactured in the USA

Model IP fans are built in one of two manufacturing locations, Schofield, WI and Shelby, NC. Multiple manufacturing locations enables us to build fans and get them to you, our customer, faster.

Quick Build Availability

Model IP fans are available in as little as 10 days on our Quick Build program.

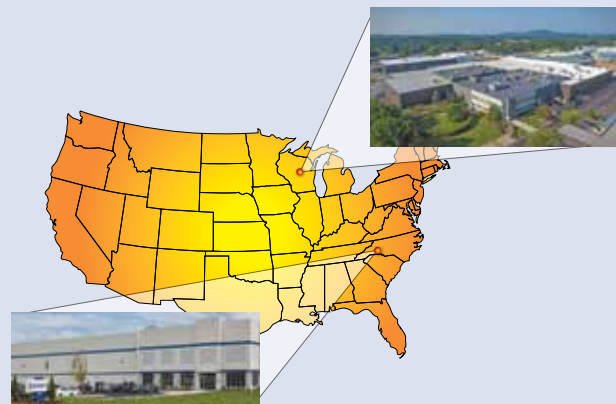

Greenheck industrial process fans are engineered and built for reliable operation in severe environments where high temperatures and static pressures, and material handling requirements are encountered.

Four Construction Levels

Capacities to 143,000 cfm and 32 in. wg.

Multiple levels of construction allow for matching the fan with the necessary performance level for its application. With four fan series to choose from, Greenheck keeps the best value in mind.

Fans are offered in inlet sizes 5-41 and are available in belt drive arrangements 1, 9 and 10 and direct drive arrangements 4 and 8. All sizes and models are available in either clockwise or counterclockwise rotation and are offered in multiple discharge positions.

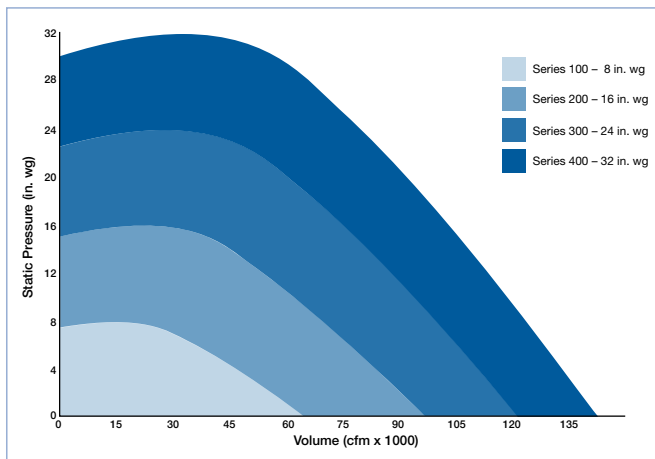

Housings

Housings are manufactured of laser cut and formed steel. Spark resistant or stainless steel construction is optional.

Electrostatic Powder Paint

All steel surfaces are coated with concrete grey (RAL 7023) Permatector™, an electrostatically applied and baked polyester, as standard. For harsher environments, see page 8 for information on other coatings offered by Greenheck.

Inlet Collars

Inlet collars are standard on all industrial process fans.

Fan Shafts

Fan shafts are turned, precision ground, polished and sized so the first critical speed is at least 25% over the maximum operating speed and horsepower.

Drive Frame



Drive frames are manufactured with heavy gauge welded steel. IP fans feature an A-frame type structural design.

Motor Mounting Plates

Motor mounting plates on arrangements 9 and 10 are provided with convenient jack-screws for belt tensioning.



Greenheck industrial process fans have wheels of the radial type. Of the three wheel types we offer, the industrial air handling wheel is the most efficient. All wheels are statically and dynamically balanced to grade G6.3 per ANSI S2.19.

	Open Radial Material Handling Wheel	Backplated/Wool Material Handling Wheel	Industrial Air Handling Wheel
Wheel Type			
Application	Abrasive dust exhaust, conveying granular materials, fume exhaust, and high temperature air handling	Conveying wood shavings, yarn, and paper trimmings	Clean air, light dust, smoke and heat exhaust, corrosives, and heavy fumes
Construction Options	Steel 316 Stainless Steel	Steel 316 Stainless Steel	Aluminum Steel 316 Stainless Steel

Premium Bearings

The industrial process series of centrifugal products are manufactured with “Air Handling Quality” self-aligning ball or roller pillow block bearings. Our standard bearings use concentric lock collars (no set screws) which ensure smooth operation and provide superior grip force between the bearing collar and fan shaft. All bearings are selected for a basic rating fatigue life of L₁₀ in excess of 40,000 hours. Our bearings include zerk fittings for relubrication.



L ₁₀ Life	Equal to L ₅₀ or Average Life
40,000 hrs.	200,000 hrs.

L₁₀ life implies 90% reliability or 10% failure rate at the stated hours.
L₅₀ life implies 50% reliability or 50% failure rate at the stated hours.



Vibration Analysis

All Greenheck industrial process products endure a complete mechanical vibration test after assembly. Our custom data acquisition system uses tri-axial accelerometers to measure vibration in three planes at the designed operating speed. A permanent record for each fan’s performance is kept on file and is available upon request.

The standard “filter-in” vibration levels attained meet the requirements of Fan Application BV-3 as defined in AMCA Standard 204-05 “Balance Quality and Vibration Levels for Fans”. The maximum allowable vibration on an industrial process fan is 0.15 in/sec peak velocity, at the fan bearings, for the specified RPM.



Alternative Materials

Greenheck offers some industrial process fans in stainless steel construction as an alternative to coated steel. Stainless steel (316L) construction is used for environments subject to continuous high heat up to 1000°F (538°C) or for severe corrosives.

Stainless steel construction is applied to the entire fan (housing, wheel, inlet cone and drive frame).

Note: Bolt on components such as weatherhoods and guards are NOT stainless construction.

Spark Resistant Construction

Greenheck centrifugal fans are available with spark resistant designs suitable for applications that involve flammable particles, fumes or vapors. Spark resistant construction options adhere to guidelines defined within AMCA Standard 99-0401.

Spark A	All parts in contact with the airstream are constructed of nonferrous material (usually aluminum).
Spark B	The fan wheel is constructed of a nonferrous material (usually aluminum). A nonferrous (aluminum) rub ring surrounds the fan shaft where it passes through the fan housing.
Spark C	The inlet cone is constructed of nonferrous material (usually aluminum). A nonferrous (aluminum) rub ring surrounds the fan shaft where it passes through the fan housing.

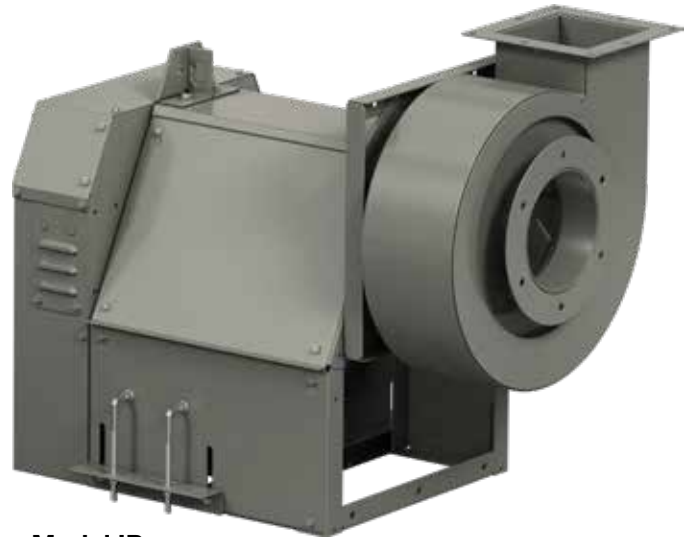

Model IP
Arrangement 10

Construction Options

High Temperature Process Construction

The industrial process fan models are available in a wide variety of configurations to meet continuous high temperature exhaust requirements. Our high temperature process packages include a heat slinger, high temperature fan bearing grease, and high temperature paint for steel housed fans.

Temperature Option	Arrangement	Material
251–500°F (121–260°C)	1, 8, 9, 10	Steel, 316 Stainless Steel
501–750°F (261–398°C)	1, 8	Steel, 316 Stainless Steel
751–1000°F (399–538°C)	1	316 Stainless Steel

Computer Aided Product Selection

All Greenheck products are supported by the industry's best product literature, electronic media and two product selection tools – our Computer Aided Product Selection program (CAPS®) and eCAPS®, our online selection tool. Electronic copies of our product literature are found online as well as storage, installation and maintenance information in our Installation and Operation Manuals.

And, of course, you can always count on the personal service and expertise of our national and international representative organization. To locate your nearest Greenheck representative call 715-359-6171 or visit our website at www.Greenheck.com



Arrangement 10* – Belt Drive

- Compact design providing space savings.
- Bearings are located out of the airstream.
- Motor is mounted beneath the drive frame.
- Available with a heat fan package up to 500°F (260°C).

*Only arrangement available with a weatherhood.

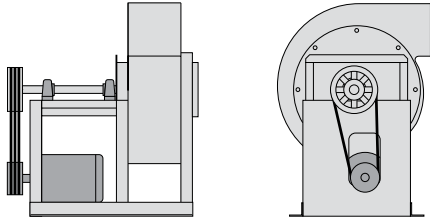

Arrangement 9 – Belt Drive

- Easy access to motors mounted on drive frame.
- Bearings are located out of the airstream.
- Available with larger motors than arrangement 10.
- Standard motor position is on the right side of the drive frame.
- Recommend belt guard and shaft guard.
- Available with a heat fan package to 500°F (260°C).

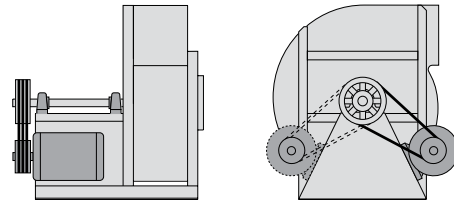

Arrangement 1 – Belt Drive

- Bearings are located out of the airstream.
- Recommended for large frame motors, easiest motor access.
- Motor is mounted on a common isolation base with fan.
- Choice of motor positions W, X/Y or Z (see page 7).
- Recommend belt guard and shaft guard.
- Recommended for high temperatures or contaminated air.
- Available with heat fan packages to 1000°F (537°C).

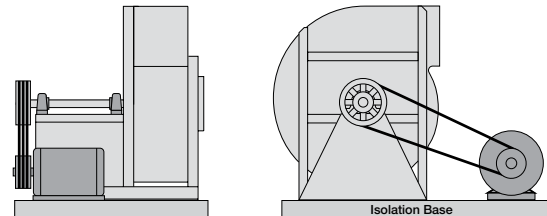

Arrangement 4 – Direct Drive

- Wheel mounted directly to motor shaft – no drive loss.
- Provides compact design with low maintenance.
- Limited to standard motor speeds, but are available with variable frequency drive compatible motors.
- Suitable for clean or contaminated air applications.
- Heat fan packages are not available.

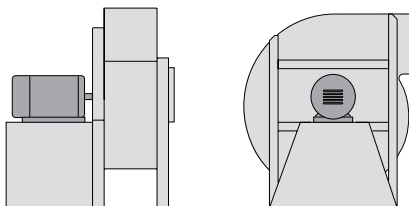

Arrangement 8 – Direct Drive

- Direct drive coupled to fan shaft.
- Bearings are located out of the airstream.
- Limited to standard motor speeds, but are available with variable frequency drive compatible motors.
- Suitable for high temperatures or contaminated air.
- Recommend shaft guard.
- Available with heat fan packages to 800°F (427°C).

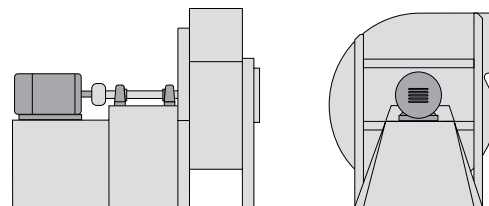

Discharge Positions and Rotatable Housings

All industrial process fans are available with clockwise (CW) or counterclockwise (CCW) rotation in all standard discharge positions. Fans sizes 5-19 feature rotatable housings as standard.

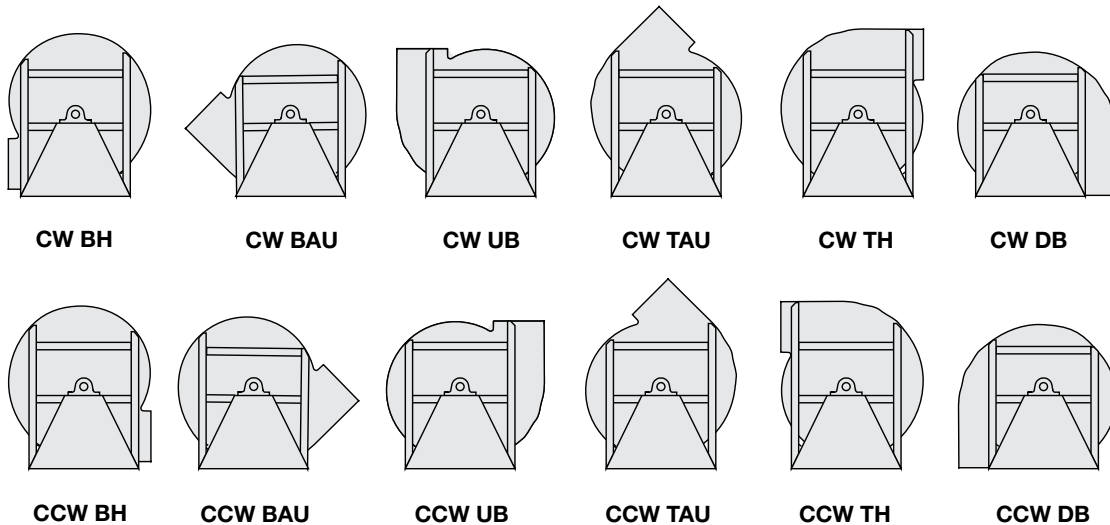

Motor Positions – Arrangement 1 Fans

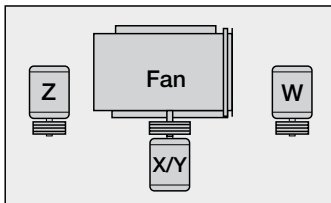

Motor position and fan rotation are determined from drive side

Fan arrangement 1 requires a structural steel base or structural platform to support the fan and motor. The motor can be located in any of three positions around the fan shaft to ensure proper alignment. Motor positions W and Z tend to make a longer footprint from end to end. Position X/Y tends to make a shorter but wider footprint.

Motors

Greenheck offers a wide variety of 50 and 60 Hz motors suitable for clean air to severe duty chemical exhaust applications. Our basic motors meet the efficiency guidelines determined by IHP (Integral Horsepower Motor rule effective June 1, 2016 from the U.S. Department of Energy). For international projects, some less efficient motor options may be available. Variable Frequency Drive (VFD) compatible motors are available for most motor duties and configurations.

Protective Coatings

Greenheck offers a wide variety of protective coatings suitable for corrosive applications. All coatings are electrostatically-applied baked powders that offer a durable, long lasting finish. For more information on our complete offering of coatings, visit the industrial centrifugal fans page on www.greenheck.com and click on the Other Product Information section at the bottom of the page to find the [Coatings Application Guide and Performance Coatings flyer](#).

Chemical Resistance Ratings						
Chemical	Bleach	Sulfuric Acid (10%)	HCl (10%)	MEK	Chlorine (0.1%)	NaOH (20%)
Permatector™	0	1	2	2	0	—
Hi-Pro Polyester	0	0	0	1	0	—
Hi-Pro-Z	0	0	0	1	0	1
RATING DESCRIPTIONS	0 - No effect 1 - Slight change in gloss or color 2 - Surface etching, severe staining, but film integrity remains 3 - Significant pitting, cratering, swelling, or erosion with obvious surface deterioration					

Two-Coat Advantage

For corrosive environments, use Greenheck’s Hi-Pro-Z two-coat coating technology. Test data demonstrates our two-coat paint system offers four times the corrosion resistance of other coatings commonly available within the fan industry.

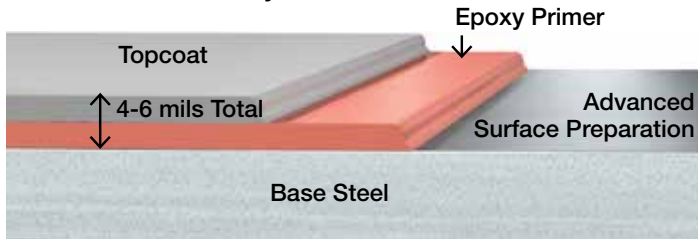

Performance Tested

When selecting a powder coating finish for heavy-gauge welded steel fans, critical information such as environment, moisture, exposure, abrasives, and chemicals should be considered.

Powder coatings are the best choice for most extreme applications. Major advantages over most vendor-applied liquid coatings include:

- Superior finish with uniform coverage and thickness
- A better coating provides better protection
- Environmentally-friendly process
- Unequaled value

	Coatings	Color	Coating Specifications	Environments						
				CLEAN AIR	COASTAL	CHEMICAL*	EXTREME WEATHER	ABRASIVE PARTICLES	SUN-UV	
One Coat Process	Permatector™ Standard coating for steel products in both indoor and outdoor applications.	Concrete Grey RAL 7023	Thickness: 2.0 - 3.0 mils Polyester powder coating	X						
	Hi-Pro Polyester Formulated for exterior durability, color and gloss retention. Excellent for chemical applications.		Thickness: 2.0 - 3.0 mils High performance polyester powder coating	X		X			X	
Two Coat Process	Hi-Pro-Z Two-coat powder paint coating is resistant to saltwater, chemical fumes and moisture in corrosive environments.		Thickness: 4.0 - 6.0 mils Hi-Pro polyester topcoat with epoxy basecoat	X	X	X	X	X	X	

Note: Hi-Pro-Z is not available on aluminum.

*Chemical Resistant Rating Above

Isolation Bases and Vibration Isolators

Greenheck offers a complete package of vibration isolators, isolation bases and inertia bases to simplify field assembly and reduce transmitted vibrations.

Refer to the catalog on www.greenheck.com/Resources/Library/Literature. Search for [Mounting Bases and Vibration Isolation](#).

Mounting Types

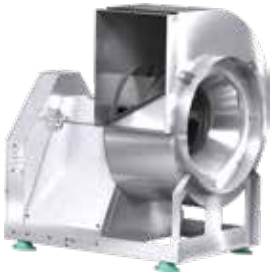

Direct Mount

No base required, isolators are attached directly to equipment. Direct isolation can be used if equipment is unitary and rigid without the use of additional support. Direct isolation is not recommended for equipment having large overhung loads (e.g. motors on arrangement 9 fans). If there is any doubt that equipment can be supported directly on isolators, use bases or consult the factory.

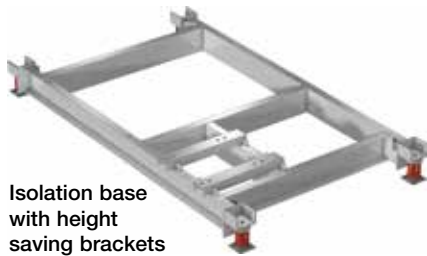

Isolation base with height saving brackets

Isolation Base

Isolation bases consist of formed steel members welded into a rigid one-piece base. A motor slide base is included where applicable. Bases are required for all arrangement 1 and 3 fans with independently mounted motors. Isolation bases are available without isolators, with rubber mounts or with spring mounts. All formed steel bases with spring mounts incorporate height saving brackets.



Inertia base

Inertia Base

Inertia bases may be desirable where isolation bases do not provide sufficient mass or where discharge velocities cause greater reaction forces. The additional weight of the concrete reduces the vibration amplitude and reduces reaction forces from fan thrust and start and stop motion. Concrete is by others.

Note: Motor slide base is included on arrangement 1 & 3 fans.

Isolator Types



Neoprene

Rubber Mount

Rubber mountings consist of a steel top plate and base plate completely embedded in colored (oil-resistant) rubber for easy identification of capacity. Rubber mountings are furnished with a tapped hole in the center. This enables the equipment to be bolted securely to the rubber mount.



Restrained

Restrained Spring Mount

Restrained spring isolators consist of laterally stable, free-standing springs assembled into a steel housing. These assemblies are designed for vertical and horizontal motion restraint. Springs provide 50% overload capacity and are color coded or identified to indicate load capacity. Restrained spring mounts are recommended for equipment subject to wind-loading or large torquing forces.



Free Standing

Free-Standing Open Spring Mount

Free-standing spring isolators are unshoused laterally stable steel springs. They provide a minimum horizontal stiffness of 0.8 times the rated vertical stiffness and provide an additional 50% overload capacity. These isolators are equipped with a top mounted adjusting bolt and an acoustical non-skid base. Springs are color coded or identified to indicate load capacity.

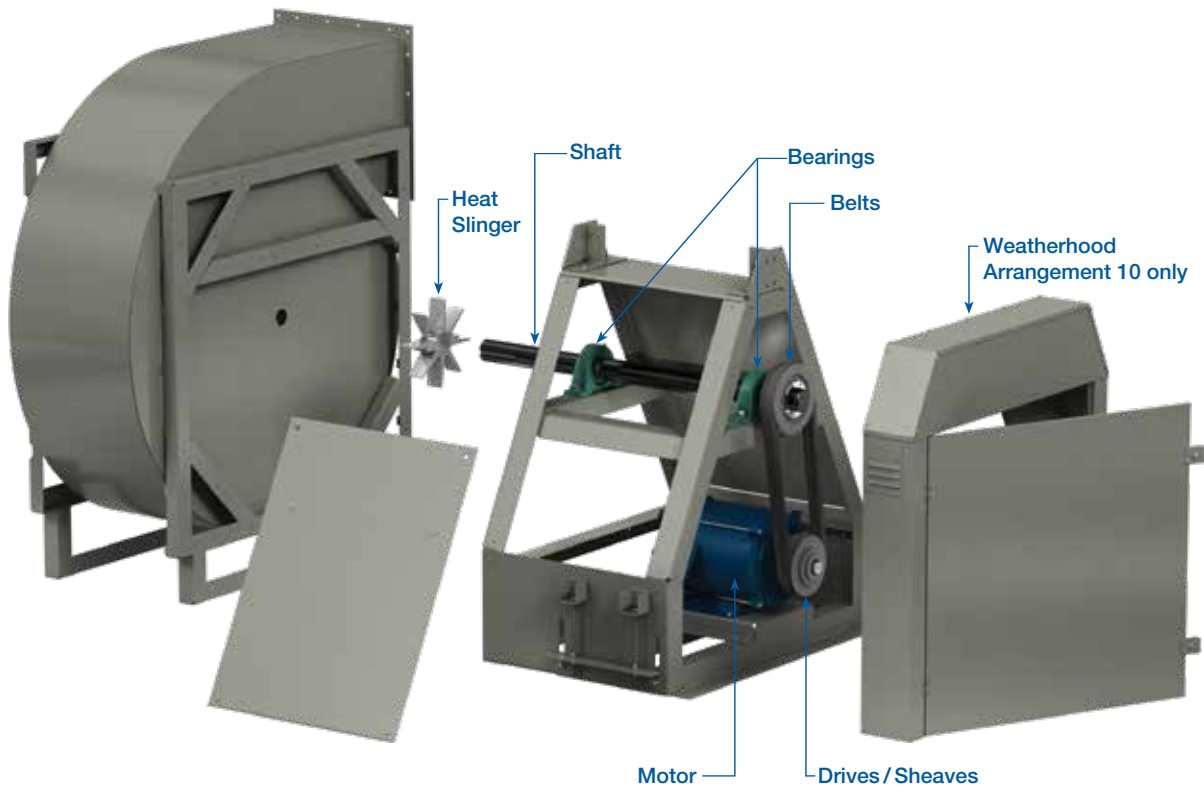
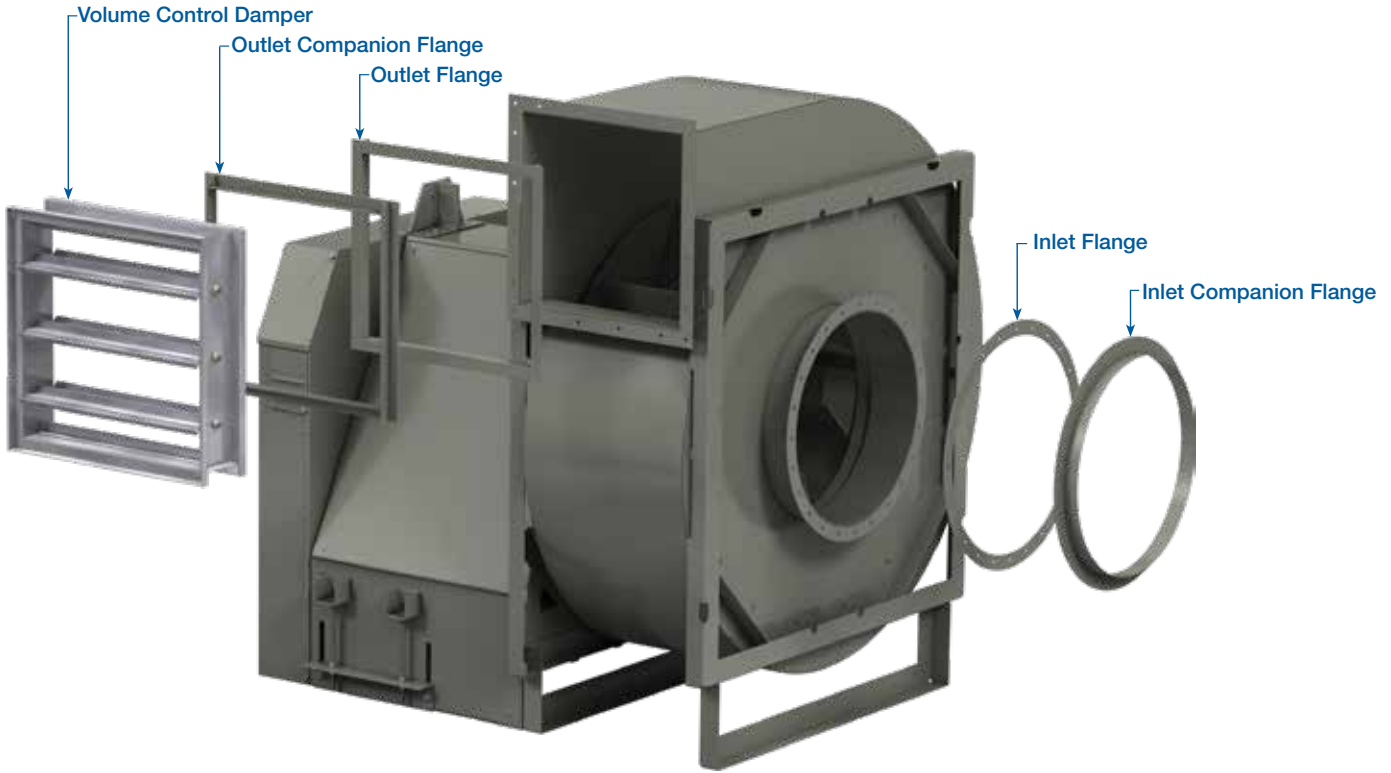

Weatherhoods (for Arr. 10 only)

Vented steel weatherhoods protect the motor and drive components from rain, moisture, dust, and dirt. Weatherhoods meet OSHA guidelines and are easily removed for service access.

Belt Guard

Belt guards are designed to allow easy access to the belts and pulleys for service. All belt guards include tachometer openings to monitor the fan speed as well as an access panel for testing belt tension. Belt guards meet OSHA guidelines.

Shaft Guard

Shaft guards are designed to cover shafts and bearings on arrangement 1, 8, 9, or 10 configurations. Extended lube lines are optional for bearing lubrication without removal of the guard. Shaft guards meet OSHA guidelines.

Inlet and Outlet Flanges*

Punched inlet flanges are available on all fan sizes and constructions. Punched outlet flanges are standard on all IP model fans.

Access Doors*

Bolted access doors provide access for cleaning or inspection.

Companion Flanges*

Punched companion inlet and outlet flanges are available for all fan sizes.

Drain Connection*

A one-inch (25 mm) threaded drain connection is located at the bottom of the fan housing to drain water that may accumulate.

Heat Slings

The heat slinger is an aluminum cooling disc mounted on the fan shaft between the inboard bearing and the blower housing to dissipate heat conducted along the fan shaft.

Shaft Seals

A shaft seal is available for operation at high temperatures or for exhausting contaminated air. Not a gas-tight seal.

Extended Lubrication Lines

Industrial process fans are available with flexible nylon or copper tubing extending from the bearings to conveniently located grease fittings mounted on the fan drive frame (or on the fan housing if a weatherhood is supplied).

Disconnect Switches

Greenheck offers a wide selection of NEMA rated fusible or non-fusible disconnect switches.

Volume Control Dampers

Volume control dampers are available for IP models constructed with the air handling wheel. Control dampers are available in painted steel only, using manual quadrant (manual lever arm) actuators.



Industrial Control Damper Model HCD

Fan Monitoring System (FMS)

The FMS package includes a preprogrammed monitor along with a wide selection of commonly applied sensors to monitor the overall equipment health, planned maintenance and monitor energy use.

Motor Starters

The fundamental function of a motor starter is to protect the motor from damage that can occur from over amping. With a Greenheck motor starter you will be provided with the best motor protection available.



**These accessories are available in aluminum or stainless steel construction.*

Specifications and Selection Support

Typical Specification

Process or material handling fans shall be of the heavy duty type with inlet diameters and outlet areas manufactured in accordance with standards adopted by AMCA for industrial process fans.

Fan housings shall be of continuously-welded plate to assure no air leakage. The housing and bearing support shall be constructed of welded steel members to support the shaft and bearings.

The fan wheel shall be fully welded and of either the open material handling, backplate material handling or air handling type. Wheels shall be statically and dynamically balanced to balance grade G6.3 per ANSI S2.19.

Turned, precision ground and polished steel shafts shall be sized so the first critical speed is at least 25% over the maximum operating speed for each construction class. Close tolerances shall be maintained where the shaft passes through the bearing.

Bearings shall be heavy duty grease lubricated, ball or roller pillow block type. Bearings shall be selected for a basic rating fatigue life L_{10} of 40,000 hours at maximum operating speed and horsepower for each construction level.

Each assembled fan shall be test run at the factory at the specified fan RPM and vibration signatures shall be taken on each bearing in the horizontal, vertical, and axial direction. The maximum allowable fan vibration shall be 0.15 in/sec peak velocity, filter in, measured at the fan RPM.

Fans shall be licensed to bear the AMCA Seal for Air Performance.

Industrial process fans shall be model IP as manufactured by Greenheck Fan Corporation of Schofield, Wisconsin, USA and shall be supplied as shown on the plans and in the fan schedule.



Enjoy Greenheck's extraordinary service, before, during and after the sale.



Greenheck offers added value to our wide selection of top performing, energy-efficient products by providing several unique Greenheck service programs.

- Our Quick Delivery Program ensures shipment of our in-stock products within 24 hours of placing your order. Our Quick Build made-to-order products can be produced in 1-3-5-10-15-20 or 25-day production cycles, depending upon their complexity.
- Greenheck's free Computer Aided Product Selection program (CAPS®), rated by many as the best in the industry, helps you conveniently and efficiently select the right products for the challenge at hand.
- Our 3D service allows you to download, at no charge, easy-to-use AutoDesk® Revit® 3D drawings for many of our ventilation products.

Find out more about these special Greenheck services at greenheck.com

Our Commitment

As a result of our commitment to continuous improvement, Greenheck reserves the right to change specifications without notice.

Product warranties can be found online at Greenheck.com, either on the specific product page or in the literature section of the website at Greenheck.com/Resources/Library/Literature.

