

# Laboratory Exhaust Systems

## Vektor®-H Performance

High Plume

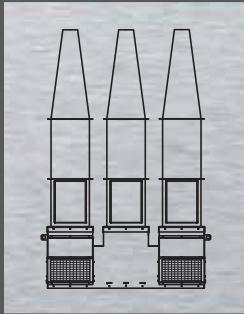
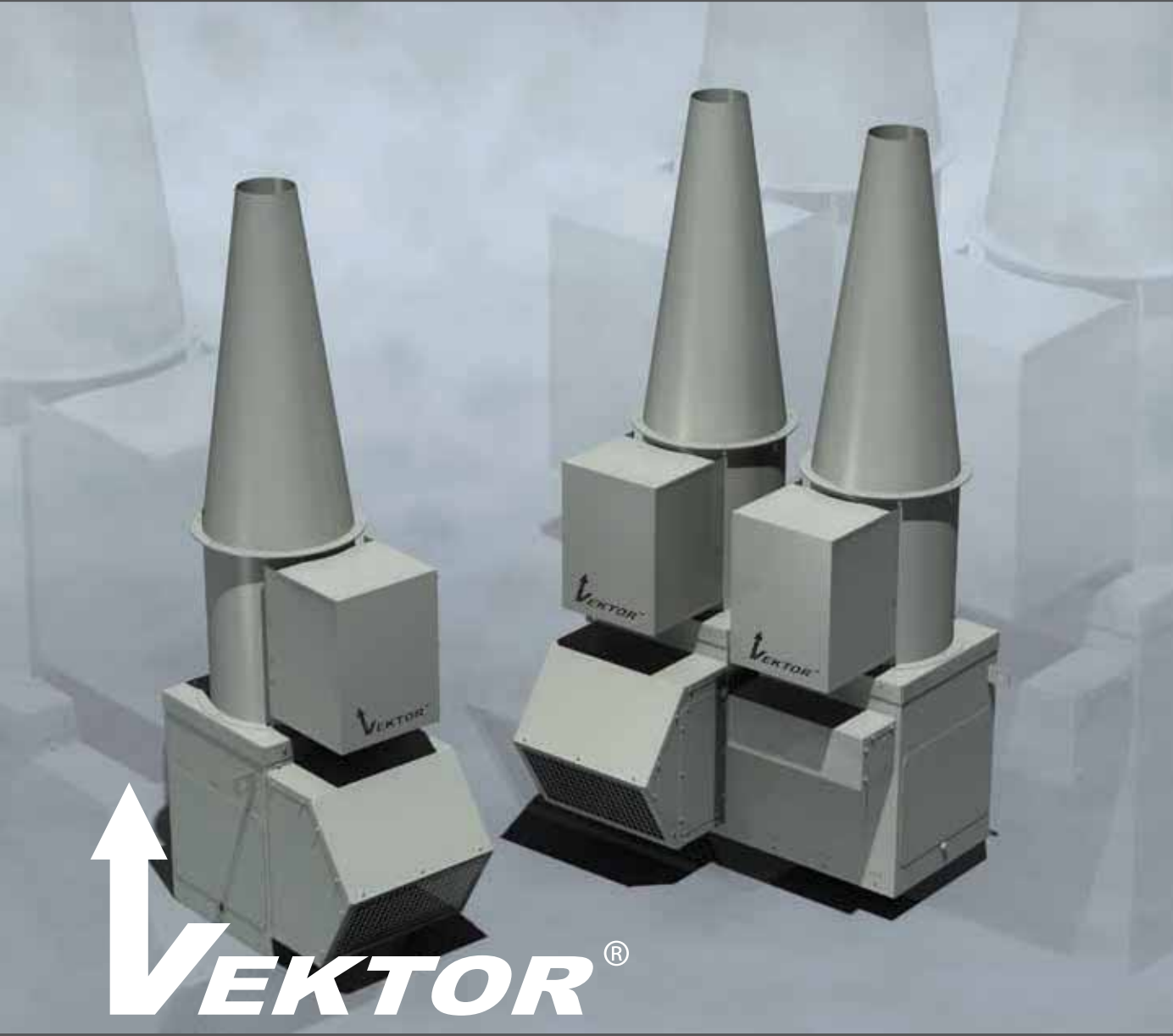

 **GREENHECK**  
Building Value in Air.

# Laboratory Exhaust Systems

## Model Vektor®-H

### Table of Contents

Vektor-H Specification Chart . . . . .	3
Plume Height Calculation . . . . .	3
Quick Select Chart . . . . .	4
Air Density Correction Factors . . . . .	4-5
Reading Fan Curves . . . . .	5
Air Data and Fan Curves. . . . .	6-21
Sound Instructions & Reading Sound Data . . . . .	22
Sound Data . . . . .	23-27



### Licenses and Certifications

#### AMCA

Greenheck Fan Corporation certifies that the Model Vektor®-H lab exhaust fans shown herein are licensed to bear the AMCA seal. The ratings shown are based on tests and procedures performed in accordance with AMCA Publication 211 and Publication 311 and comply with the requirements of the AMCA Certified Ratings Program. The AMCA Certified Ratings Seal applies to sound and air performance.



#### UL/cUL 705 Power Ventilators

Vektor-H models are available with the UL/cUL 705 Listing on a wide variety of 50 and 60 hertz motors. This listing ensures the use of UL approved electrical components. Motors are available in NEMA totally enclosed, fan cooled (TEFC), or explosion proof (EXP) designs.



Model Vektor-H is available with the UL/cUL 705 Power Ventilators File #E40001

#### UL/cUL 762 Power Ventilators for Restaurant Exhaust Appliances

UL/cUL 762 is concerned with fans designed for removal of smoke and grease laden vapors and is designed to withstand the demands of high temperature kitchen grease exhaust. The Vektor-H is an alternative for kitchen applications when the requirement for a high plume rise is deemed necessary.



Model Vektor-H is available with the UL/cUL 762 Power Ventilators for Restaurant Exhaust Appliances Maximum Operating Temperature 400°F File #MH11745

### Standards

**ANSI/AIHA Z9.5** – Laboratory Ventilation American National Standards Institute, Inc.

**NFPA 45** – Standard on Fire Protection for Laboratories using Chemicals

**NFPA 90A** – Installation of Air Conditioning and Ventilating Systems

**NFPA 91** – Exhaust Systems for Air Conveying of Materials

# Vektor-H Specifications

<b>Nozzle Diameter</b>	4	5	6	7	8	9	10	11	12	13	14	15	16	
<b>Nozzle Area (ft<sup>2</sup>)</b>	0.0873	0.1364	0.1963	0.2673	0.3491	0.4418	0.5454	0.6600	0.7854	0.9218	1.0690	1.2272	1.3963	
<b>Nozzle Diameter</b>	17	18	19	20	22	24	26	27	28	30	32	34	36	38
<b>Nozzle Area (ft<sup>2</sup>)</b>	1.5763	1.7671	1.9689	2.1817	2.6398	3.1416	3.6870	3.9761	4.2761	4.9087	5.5851	6.3050	7.0686	7.8758

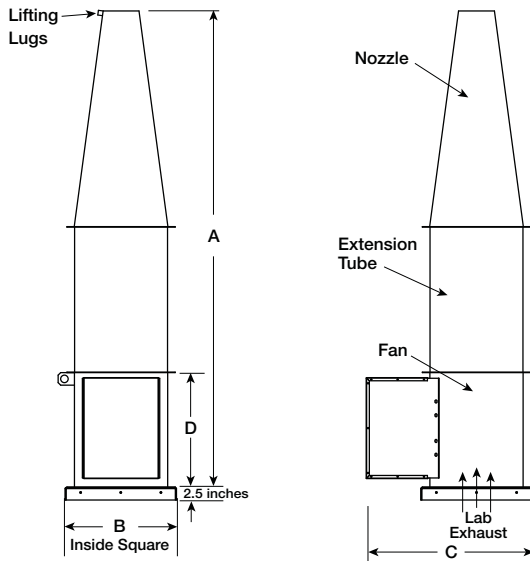

Size	A*	B	C	D	Weight (lbs)**
9	122.00	22	32.5	23.0	258
10	122.00	22	32.5	23.0	258
12	122.00	22	32.5	23.0	268
13	122.50	24	35.5	24.5	304
16	122.50	28	39.5	28.5	374
18	122.00	34	45.5	31.0	465
22	121.25	40	54.0	35.25	586
24	122.00	46	59.5	42.0	770
30	131.50	52	68.25	48.5	1039
36	143.00	58	74.5	54.0	1253

\* A dimension is for fan without bypass air plenum.

\*\* Weight does not include motor or drive pulleys.

All dimensions given on this page are in inches. Data shown on this page is for general information only and should not be used for exact installation dimensions. For detailed dimensional data please refer to the appropriate submittal drawing.

## Chemical Emission and Odor Dispersion – Plume Height Calculations

The effective plume height is an important factor in designing exhaust systems servicing laboratories. The effective plume height needs to be high enough to avoid exhaust re-entrainment into the same or adjacent buildings. Fan discharge type, concentration levels and airflow volumes all affect the needed effective plume height. The effective plume height ( $h_e$ ) is the physical height of the fan system ( $h_s$ ) plus the plume rise ( $h_r$ ).

ASHRAE 2015 Applications Handbook (Chapter 45) on laboratory design and the Greenheck CAPS program use a geometric formula called momentum flux equation to calculate plume rise ( $h_r$ ). The formula takes into account downwind distance, height of the building, prevailing wind speed and the terrain factor surrounding the building.

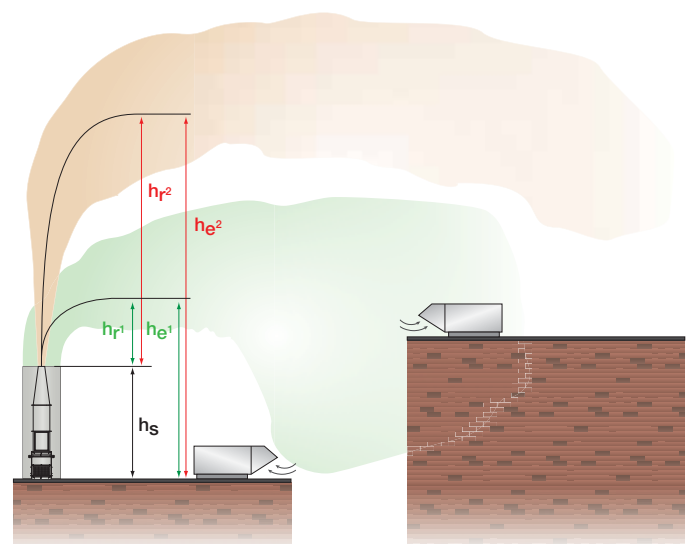

# Adjusting for Plume Height

Adjusting the fan system to have additional throw or plume height is achieved by increasing the volume of air through the discharge nozzle. Simply changing the drive pulleys will increase fan speed and volume capacity, thus boosting flow momentum. The additional air through the fan comes from an increase in lab exhaust or an increase of air through a bypass air damper. Utilizing a bypass air damper to increase both dilution and mass of the exhaust air can optimize plume rise. Increased mass improves flow momentum and carries the diluted exhaust higher.

Quick Select Chart					
Size	CFM		Plume Rise Above Roof (ft)		
			3000 ft/min.	3500 ft/min.	4000 ft/min.
9	Min	270	14	15	16
	Max	1,705	19	20	21
10	Min	420	15	16	17
	Max	1,960	19	20	21
12	Min	600	16	17	18
	Max	2,640	20	22	24
13	Min	810	17	18	19
	Max	3,160	21	23	25
16	Min	1,050	18	19	20
	Max	7,080	25	27	29
18	Min	1,320	19	20	21
	Max	7,880	26	29	31
22	Min	1,650	20	21	22
	Max	10,560	30	33	36
24	Min	2,760	22	24	26
	Max	14,760	33	37	41
30	Min	3,690	24	26	28
	Max	19,640	37	41	45
36	Min	5,310	26	29	31
	Max	24,000	42	47	52

NOTE: All plume rise values are based on 3,000 ft/min. minimum discharge velocity per ANSI Z9.5 plume rise calculation at 10 mph crosswind per ASHRAE Applications Handbook.

This chart will narrow fan selection to suit application specifications. When manually selecting a fan it is important to remember that more than one fan is available to meet the desired performance (cfm and Ps). Selection criteria such as unit size, efficiency, speed, outlet velocity, horsepower, or construction material may also dictate which fan is chosen.

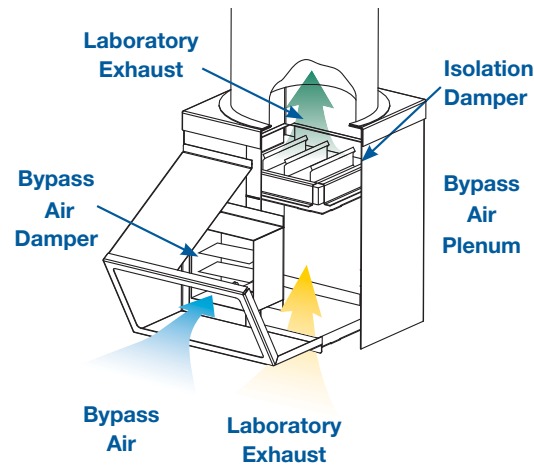

### Bypass Air Plenums

Variable volume lab exhaust systems and systems adding bypass air require a bypass air damper and plenum.

When calculating necessary pressure, 0.2 in. wg must be added to the external system to account for the damper. Systems that include an isolation damper must also add 0.15 in. wg.

# Air Density Correction Factors

Air Temp. °F	Elevation (Feet Above Sea Level)															
	0	1000	2000	3000	4000	5000	6000	7000	8000	9000	10000	11000	12000	13000	14000	15000
-20	0.83	0.86	0.89	0.93	0.96	1.00	1.03	1.07	1.11	1.15	1.19	1.24	1.28	1.33	1.38	1.43
-10	0.85	0.88	0.91	0.95	0.98	1.02	1.06	1.09	1.14	1.18	1.22	1.27	1.31	1.36	1.41	1.46
0	0.87	0.90	0.93	0.97	1.00	1.04	1.08	1.12	1.16	1.20	1.25	1.29	1.34	1.39	1.44	1.50
10	0.89	0.92	0.95	0.99	1.03	1.06	1.10	1.14	1.19	1.23	1.28	1.32	1.37	1.42	1.47	1.53
32	0.93	0.96	1.00	1.04	1.07	1.11	1.15	1.20	1.24	1.29	1.33	1.38	1.44	1.49	1.54	1.60
50	0.96	1.00	1.03	1.07	1.11	1.15	1.20	1.24	1.29	1.33	1.38	1.44	1.49	1.54	1.60	1.66
70	1.00	1.04	1.08	1.12	1.16	1.20	1.24	1.29	1.34	1.39	1.44	1.49	1.55	1.60	1.66	1.72
100	1.06	1.10	1.14	1.18	1.22	1.27	1.31	1.36	1.41	1.47	1.52	1.58	1.63	1.69	1.76	1.82
125	1.10	1.14	1.19	1.23	1.28	1.32	1.37	1.42	1.48	1.53	1.59	1.65	1.71	1.77	1.84	1.90
150	1.15	1.19	1.24	1.28	1.33	1.38	1.43	1.48	1.54	1.60	1.66	1.72	1.78	1.85	1.91	1.98
175	1.20	1.24	1.29	1.34	1.39	1.44	1.49	1.55	1.60	1.66	1.72	1.79	1.85	1.92	1.99	2.07
200	1.25	1.29	1.34	1.39	1.44	1.49	1.55	1.61	1.67	1.73	1.79	1.86	1.93	2.00	2.07	2.15

### Density Correction Factor Equation

$$DCF = ((T + 460)/530) \times 1.037(E / 1000)$$

DCF = Density Correction Factor  
T = Temperature (degrees F)

E = Elevation above sea level (feet)  
Air Density (lb/ft<sup>3</sup>) = 0.075 / DCF

## Effects of Air Density

When selecting a Vektor-H to operate at a non-standard air density using standard air density tables and curves, corrections must be made to static pressure and brake horsepower.

At higher than standard elevations and temperatures, air density will be lower than standard. Therefore, one must determine the static pressure at standard density that will equate to the specified static pressure at the operating density. Since standard air density is greater than operating air density in this instance, one would expect the corrected static pressure to be greater than the operating static pressure.

**EXAMPLE:** The following example shows how to select a Vektor-H Size 18 with a 13-inch nozzle for 3000 cfm, 1.5 in. wg, 8000 ft. elevation, and 125°F temperature.

1. Since the volume exhausted by the system is not affected by density, cfm remains 3000.
2. Select the correction factor from the chart for 8000 ft. elevation and 125°F. Correction factor is 1.48.
3. Multiply specified static pressure (1.5 in. wg) by the correction factor (1.48) to determine standard air density equivalent static pressure.  $1.5 \text{ in. wg} \times 1.48 = 2.22 \text{ in. wg}$
4. Using the performance tables, enter with 2.22 in. wg and 3000 cfm.
5. At the intersection of 2.22 in. wg and 3000 cfm the fan rpm is 1710 and Bhp is 2.6.
6. Since the horsepower selected refers to standard air density, this must be corrected to reflect actual Bhp at the lighter operating air. Remember, horsepower is less at a lower air density. Divide the Bhp required (2.6) by the correction factor (1.48) selected previously to determine the Bhp at the new operating conditions  $2.6/1.48 = 1.76 \text{ Bhp}$ . This would require a minimum motor size of 2 hp.

## Selecting a Vektor-H (Reading Fan Curves)

### Vektor-H Size 18

#### 13-INCH NOZZLE

$$\%WOV = (CFM \times 100) / (RPM \times 2.62)$$

Plume Rise	
1	3000 fpm = 22.0 ft CFM = 2760
2	3500 fpm = 24.0 ft CFM = 3220
3	4000 fpm = 26.0 ft CFM = 3680

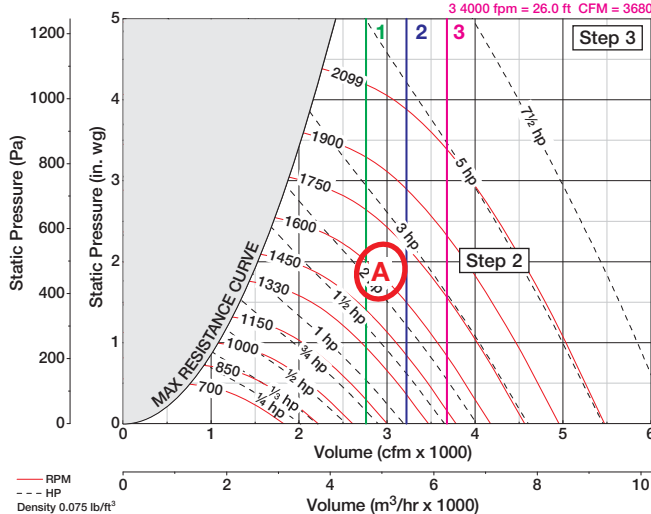

**NOTE:** All plots represent fan operation at standard air (70°C at sea level) with 10 mph crosswind. Units in the shaded area of each plot do not meet ANSI Z9.5 criteria (3,000 ft/min. minimum outlet velocity).

#### Step 1:

Identify necessary airflow (cfm) and plume rise (ft). Enter the Vektor-H Quick Select Chart located on page 4 and identify unit sizes that can accommodate application requirements.

#### Step 2:

Locate fan size that generally suits requirements. Calculate necessary system pressure including isolation damper, bypass air plenum, and system drop (refer to page 4). Enter the Fan Curve with the desired performance specifications: Airflow (cfm), Pressure (in. wg), Outlet Velocity (ft/min.) or Plume Rise (ft). This yields Horsepower (hp) and RPM at the Fan Operation Point. If the given point has a close proximity to a horsepower curve, the next larger horsepower should be selected. Plume rise is ranged by color-coded vertical lines on either side of the operation point and identified by a key in the upper right hand corner of each plot.

#### Step 3:

Calculate the exact % WOV using the equation provided with each fan curve. This value is useful when determining sound power.

#### Example A:

Lab System A requires a 3,000 cfm exhaust, 23 ft. plume rise, and 1.5 inches of wg after combining lab effluent and bypass air. From the Quick Select Chart, located on page 4, applicable unit sizes range from Vektor-H-12 to Vektor-H-24. In this example, a Vektor 18 with a 13-inch nozzle is selected to optimize unit size and required horsepower. Locating this point on the curve, a 3 hp motor operating at 1530 rpm is needed to provide a 22-24 ft. plume rise at 3,250 ft/min. Using the equation provided with the Vektor Size 18, 13-inch Nozzle Chart, the %WOV can be calculated:  $\%WOV = (3000 \times 100) / (1530 \times 262) = 75\% \text{ WOV}$

To determine Vektor-H unit sound performance, refer to page 22.

## 4-INCH NOZZLE

$$\%WOV = (CFM \times 100) / (RPM \times 0.18)$$

**Plume Rise**  
 1 3000 fpm = 14.0 ft CFM = 270  
 2 3500 fpm = 15.0 ft CFM = 315  
 3 4000 fpm = 16.0 ft CFM = 360

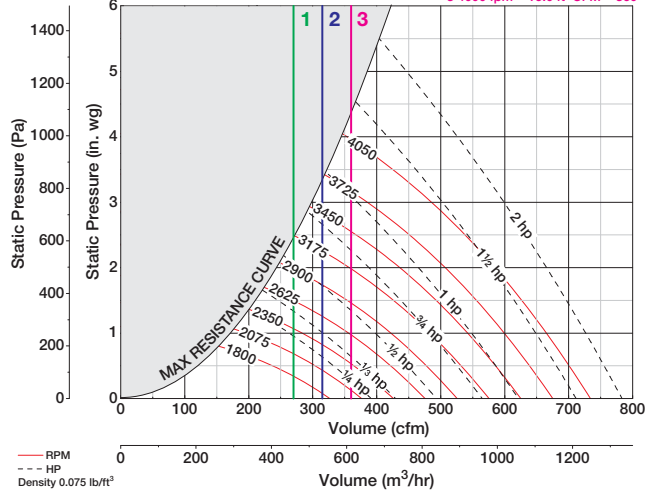

## 5-INCH NOZZLE

$$\%WOV = (CFM \times 100) / (RPM \times 0.26)$$

**Plume Rise**  
 1 3000 fpm = 15.0 ft CFM = 420  
 2 3500 fpm = 16.0 ft CFM = 490  
 3 4000 fpm = 17.0 ft CFM = 560

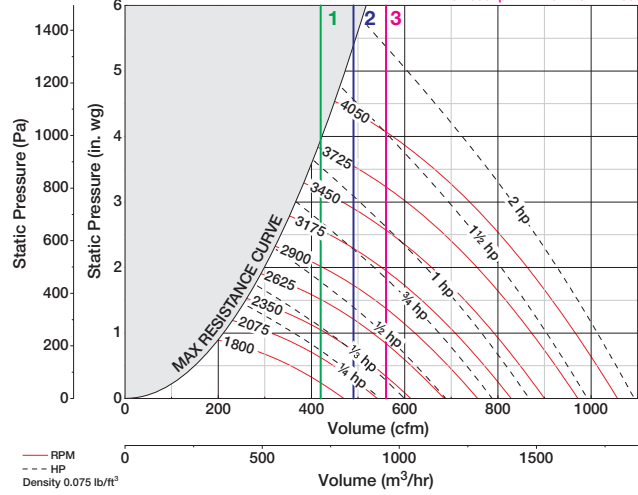

## 6-INCH NOZZLE

$$\%WOV = (CFM \times 100) / (RPM \times 0.33)$$

**Plume Rise**  
 1 3000 fpm = 16.0 ft CFM = 600  
 2 3500 fpm = 17.0 ft CFM = 700  
 3 4000 fpm = 18.0 ft CFM = 800

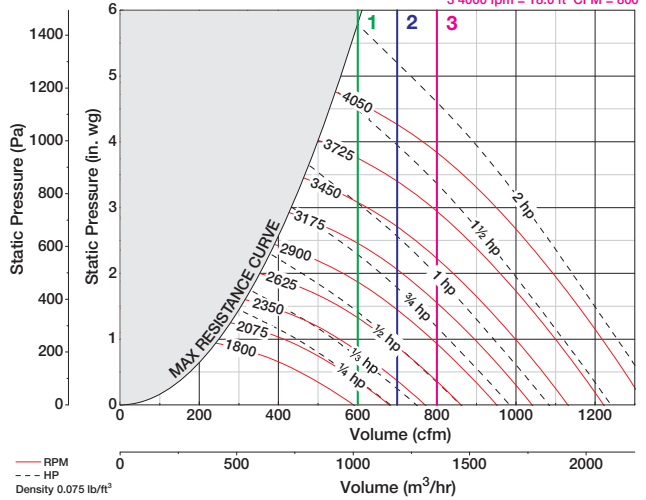

## 7-INCH NOZZLE

$$\%WOV = (CFM \times 100) / (RPM \times 0.38)$$

**Plume Rise**  
 1 3000 fpm = 17.0 ft CFM = 800  
 2 3500 fpm = 18.0 ft CFM = 945  
 3 4000 fpm = 19.0 ft CFM = 1080

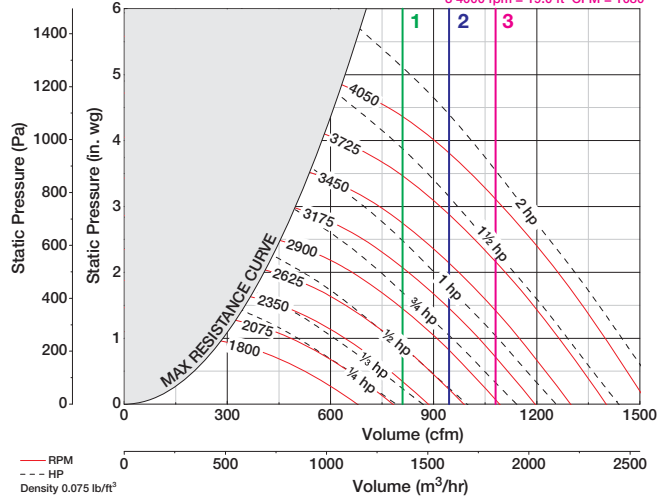

## 8-INCH NOZZLE

$$\%WOV = (CFM \times 100) / (RPM \times 0.41)$$

**Plume Rise**  
 1 3000 fpm = 18.0 ft CFM = 1050  
 2 3500 fpm = 19.0 ft CFM = 1225  
 3 4000 fpm = 20.0 ft CFM = 1400

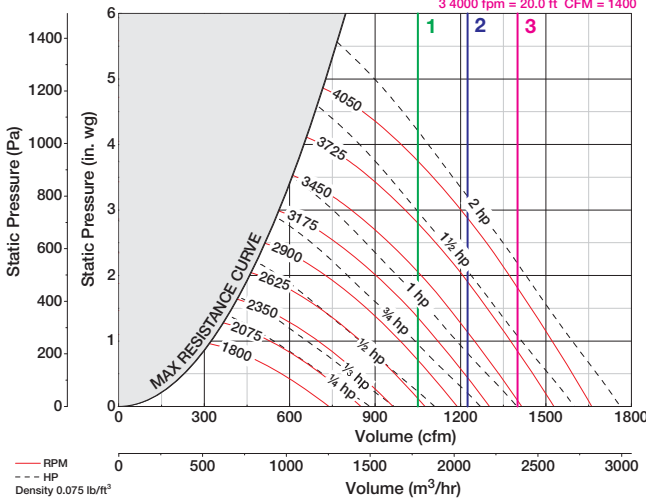

## 9-INCH NOZZLE

$$\%WOV = (CFM \times 100) / (RPM \times 0.44)$$

**Plume Rise**  
 1 3000 fpm = 19.0 ft CFM = 1320  
 2 3500 fpm = 20.0 ft CFM = 1540  
 3 4000 fpm = 21.0 ft CFM = 1760

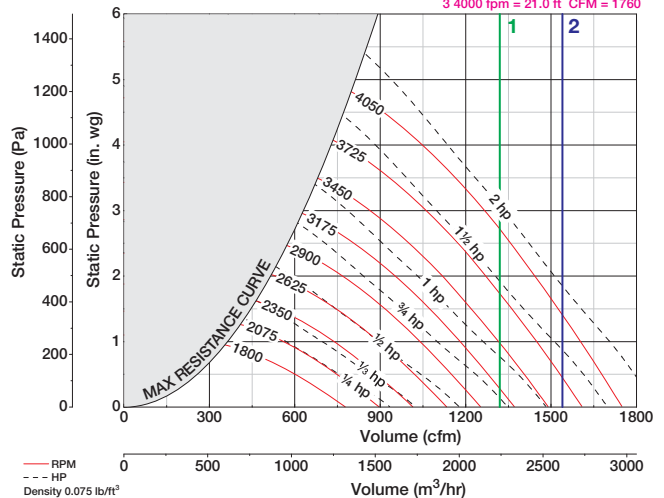

Performance certified is for installation Type A: Free inlet, Free outlet. Rating Method "A" (Constant Speed, Transmission Loss Not Included). Power rating (Bhp) does not include transmission losses. Performance ratings do not include the effects of appurtenances (accessories). Plume rise calculated assuming a 10 mph crosswind. 3,000 ft/min. is the minimum recommended outlet velocity per ANSI Z9.5.

## 5-INCH NOZZLE

$$\%WOV = (CFM \times 100) / (RPM \times 0.28)$$

### Plume Rise

- 1 3000 fpm = 15.0 ft CFM = 420
- 2 3500 fpm = 16.0 ft CFM = 490
- 3 4000 fpm = 17.0 ft CFM = 560

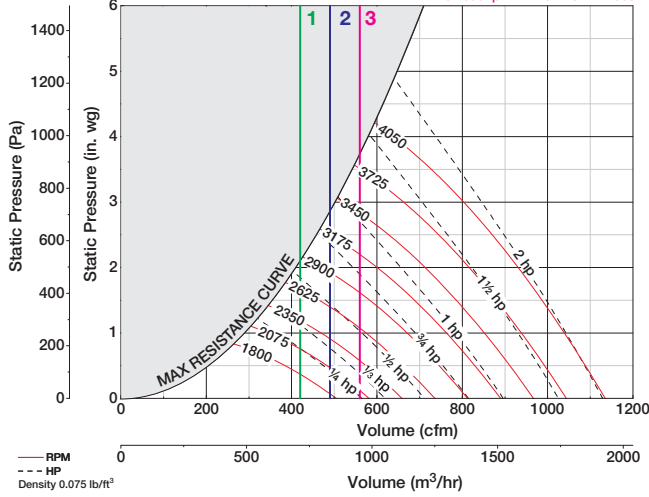

## 6-INCH NOZZLE

$$\%WOV = (CFM \times 100) / (RPM \times 0.36)$$

### Plume Rise

- 1 3000 fpm = 16.0 ft CFM = 600
- 2 3500 fpm = 17.0 ft CFM = 700
- 3 4000 fpm = 18.0 ft CFM = 800

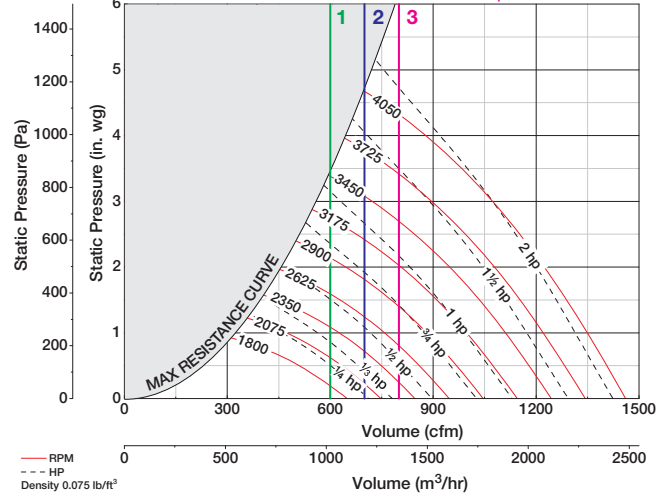

## 7-INCH NOZZLE

$$\%WOV = (CFM \times 100) / (RPM \times 0.42)$$

### Plume Rise

- 1 3000 fpm = 17.0 ft CFM = 810
- 2 3500 fpm = 18.0 ft CFM = 945
- 3 4000 fpm = 19.0 ft CFM = 1080

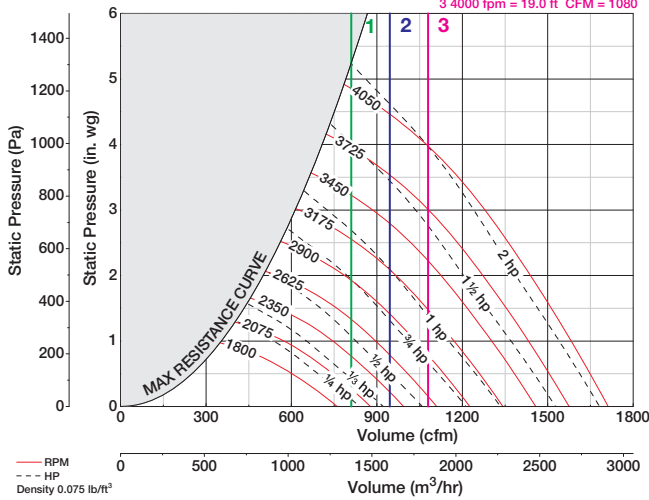

## 8-INCH NOZZLE

$$\%WOV = (CFM \times 100) / (RPM \times 0.47)$$

### Plume Rise

- 1 3000 fpm = 18.0 ft CFM = 1050
- 2 3500 fpm = 19.0 ft CFM = 1225
- 3 4000 fpm = 20.0 ft CFM = 1400

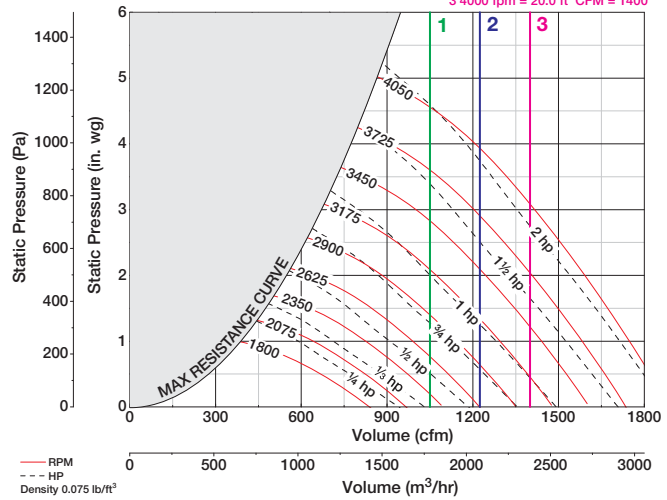

## 9-INCH NOZZLE

$$\%WOV = (CFM \times 100) / (RPM \times 0.49)$$

### Plume Rise

- 1 3000 fpm = 18.0 ft CFM = 1320
- 2 3500 fpm = 19.0 ft CFM = 1540
- 3 4000 fpm = 20.0 ft CFM = 1760

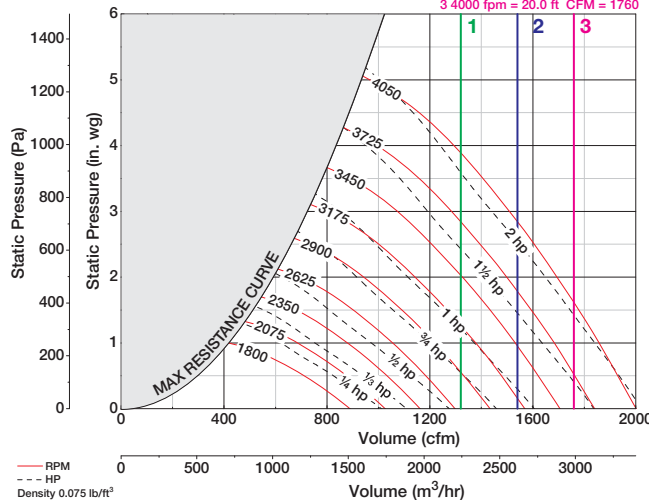

Fans are electrostatically powder coated with Labcoat™, a polyester resin electrostatically applied coating. Standard color is RAL 7023 Concrete Grey. Color match is available for non-standard colors.

Performance certified for installation Type A: Free inlet, Free outlet. Rating Method "A" (Constant Speed, Transmission Loss Not Included). Power rating (Bhp) does not include transmission losses. Performance ratings do not include the effects of appurtenances (accessories). Plume rise calculated assuming a 10 mph crosswind. 3,000 ft/min. is the minimum recommended outlet velocity per ANSI Z9.5.

## 6-INCH NOZZLE

$$\%WOV = (CFM \times 100) / (RPM \times 0.45)$$

**Plume Rise**  
 1 3000 fpm = 16.0 ft CFM = 600  
 2 3500 fpm = 17.0 ft CFM = 700  
 3 4000 fpm = 18.0 ft CFM = 800

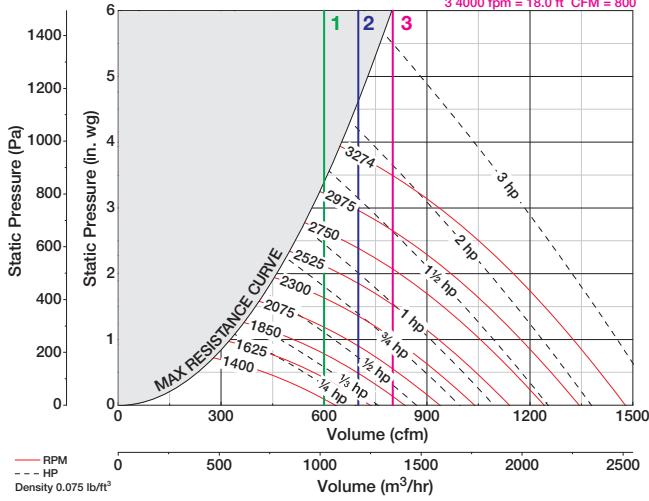

## 7-INCH NOZZLE

$$\%WOV = (CFM \times 100) / (RPM \times 0.57)$$

**Plume Rise**  
 1 3000 fpm = 18.0 ft CFM = 810  
 2 3500 fpm = 19.0 ft CFM = 945  
 3 4000 fpm = 20.0 ft CFM = 1080

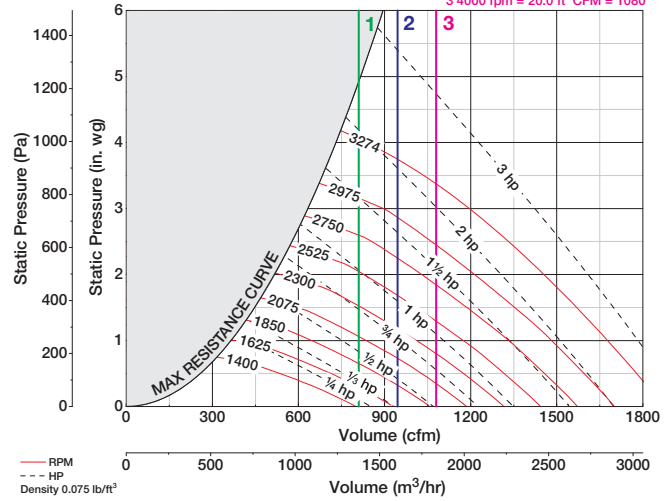

## 8-INCH NOZZLE

$$\%WOV = (CFM \times 100) / (RPM \times 0.68)$$

**Plume Rise**  
 1 3000 fpm = 18.0 ft CFM = 1050  
 2 3500 fpm = 19.0 ft CFM = 1225  
 3 4000 fpm = 20.0 ft CFM = 1400

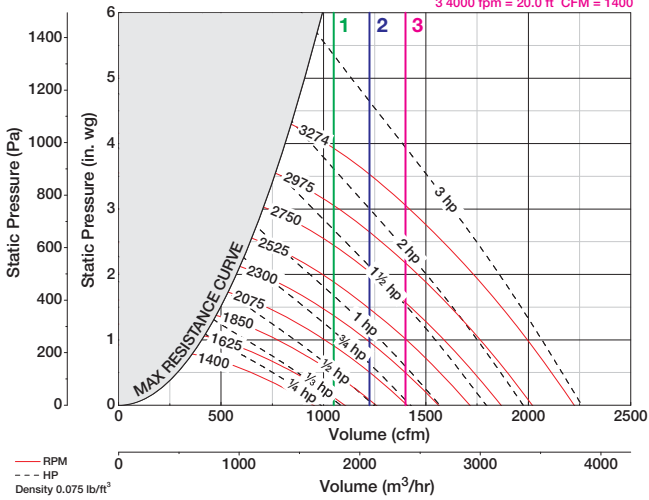

## 9-INCH NOZZLE

$$\%WOV = (CFM \times 100) / (RPM \times 0.77)$$

**Plume Rise**  
 1 3000 fpm = 19.0 ft CFM = 1320  
 2 3500 fpm = 20.0 ft CFM = 1540  
 3 4000 fpm = 21.0 ft CFM = 1760

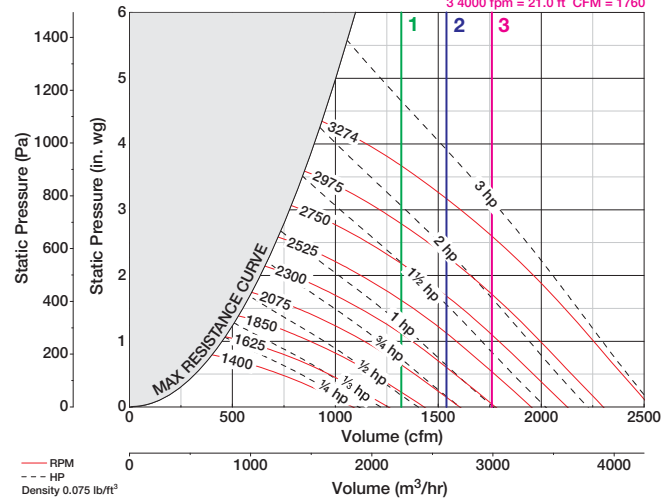

## 10-INCH NOZZLE

$$\%WOV = (CFM \times 100) / (RPM \times 0.85)$$

**Plume Rise**  
 1 3000 fpm = 20.0 ft CFM = 1650  
 2 3500 fpm = 21.0 ft CFM = 1925  
 3 4000 fpm = 22.0 ft CFM = 2200

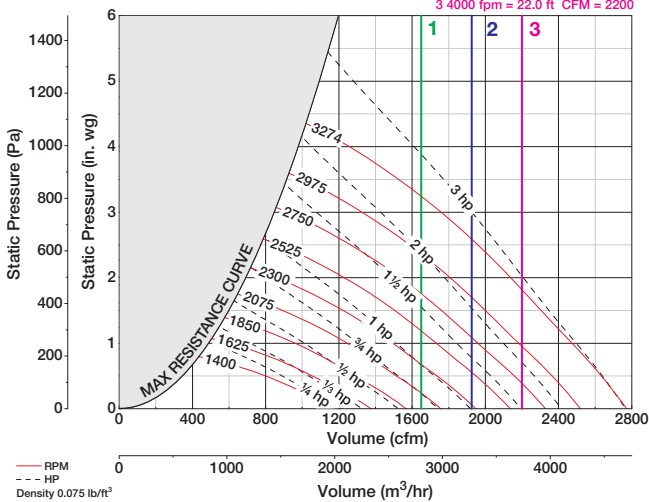

## 13-INCH NOZZLE

$$\%WOV = (CFM \times 100) / (RPM \times 0.968)$$

**Plume Rise**  
 1 3000 fpm = 22.0 ft CFM = 2760  
 2 3500 fpm = 24.0 ft CFM = 3320  
 3 4000 fpm = 26.0 ft CFM = 3680

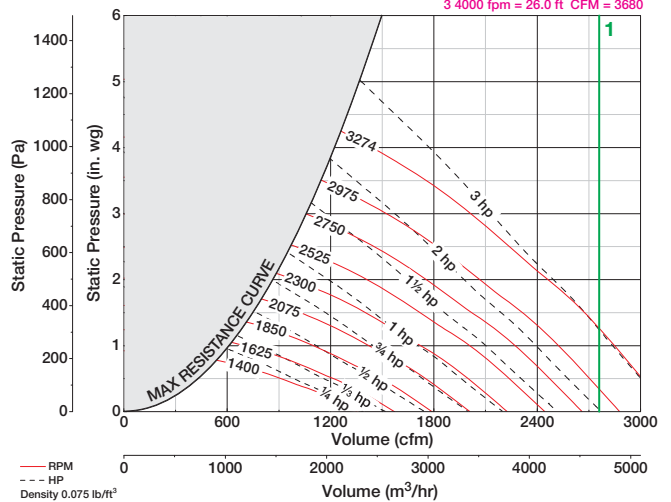

Performance certified is for installation Type A: Free inlet, Free outlet. Rating Method "A" (Constant Speed, Transmission Loss Not Included). Power rating (Bhp) does not include transmission losses. Performance ratings do not include the effects of appurtenances (accessories). Plume rise calculated assuming a 10 mph crosswind. 3,000 ft/min. is the minimum recommended outlet velocity per ANSI Z9.5.



## 7-INCH NOZZLE

$$\%WOV = (CFM \times 100) / (RPM \times 0.64)$$

### Plume Rise

- 1 3000 fpm = 18.0 ft CFM = 810
- 2 3500 fpm = 19.0 ft CFM = 945
- 3 4000 fpm = 20.0 ft CFM = 1080

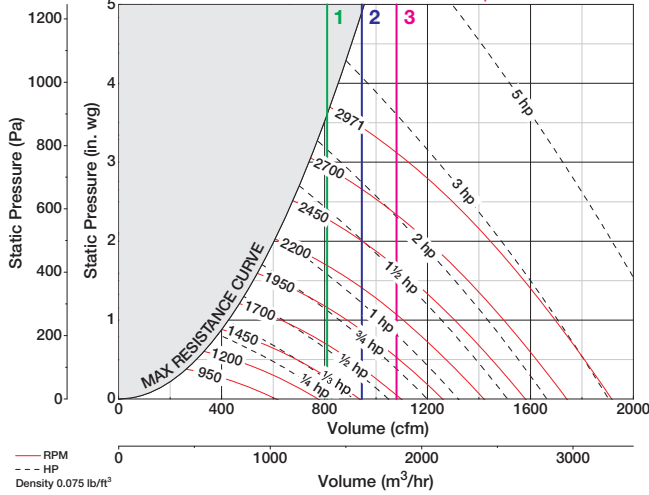

## 8-INCH NOZZLE

$$\%WOV = (CFM \times 100) / (RPM \times 0.78)$$

### Plume Rise

- 1 3000 fpm = 18.0 ft CFM = 1050
- 2 3500 fpm = 19.0 ft CFM = 1225
- 3 4000 fpm = 20.0 ft CFM = 1400

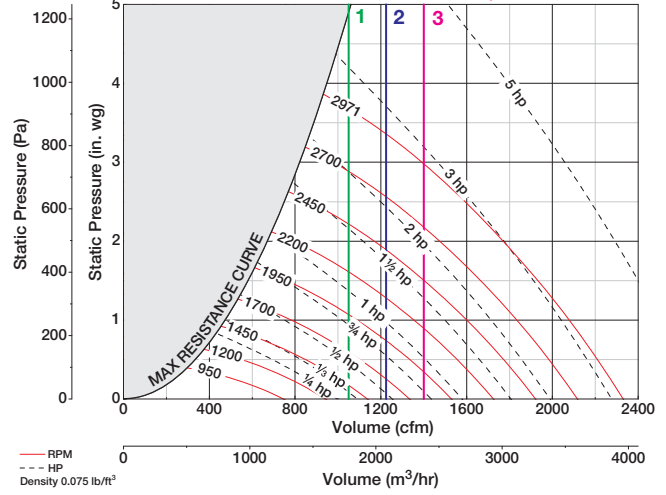

## 9-INCH NOZZLE

$$\%WOV = (CFM \times 100) / (RPM \times 0.90)$$

### Plume Rise

- 1 3000 fpm = 19.0 ft CFM = 1320
- 2 3500 fpm = 20.0 ft CFM = 1540
- 3 4000 fpm = 21.0 ft CFM = 1760

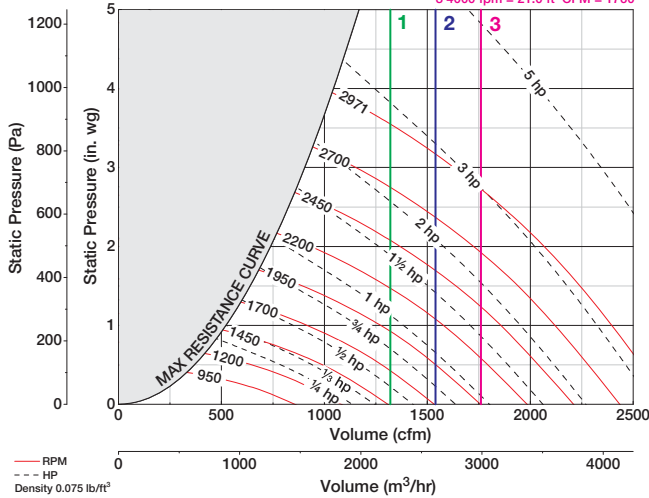

## 10-INCH NOZZLE

$$\%WOV = (CFM \times 100) / (RPM \times 0.99)$$

### Plume Rise

- 1 3000 fpm = 20.0 ft CFM = 1650
- 2 3500 fpm = 21.0 ft CFM = 1925
- 3 4000 fpm = 22.0 ft CFM = 2200

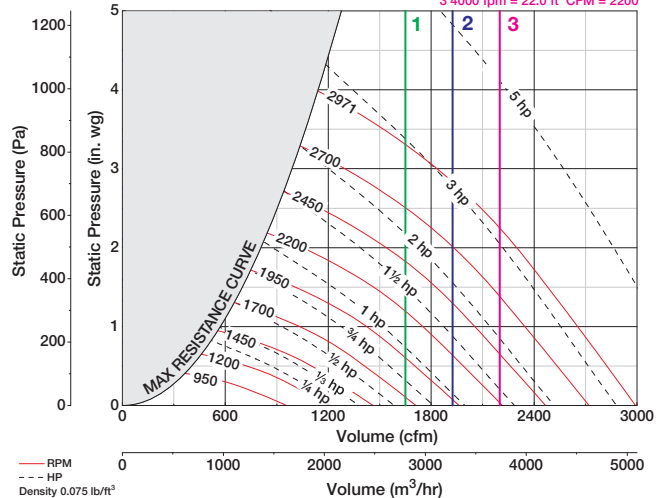

## 11-INCH NOZZLE

$$\%WOV = (CFM \times 100) / (RPM \times 1.09)$$

### Plume Rise

- 1 3000 fpm = 20.0 ft CFM = 1980
- 2 3500 fpm = 22.0 ft CFM = 2310
- 3 4000 fpm = 24.0 ft CFM = 2640

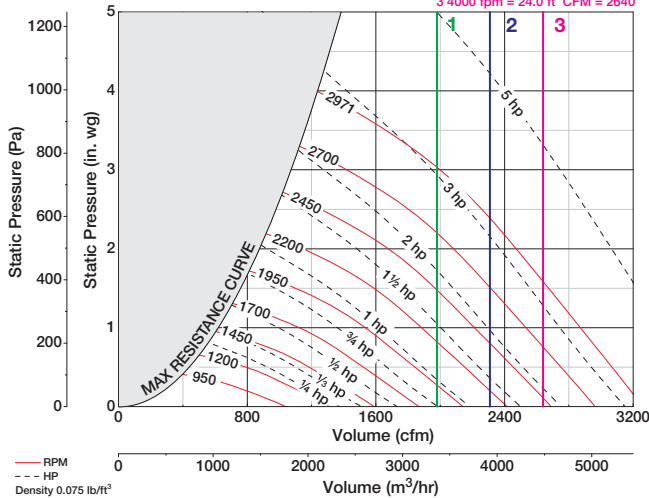

## 12-INCH NOZZLE

$$\%WOV = (CFM \times 100) / (RPM \times 1.16)$$

### Plume Rise

- 1 3000 fpm = 21.0 ft CFM = 2370
- 2 3500 fpm = 23.0 ft CFM = 2765
- 3 4000 fpm = 25.0 ft CFM = 3160

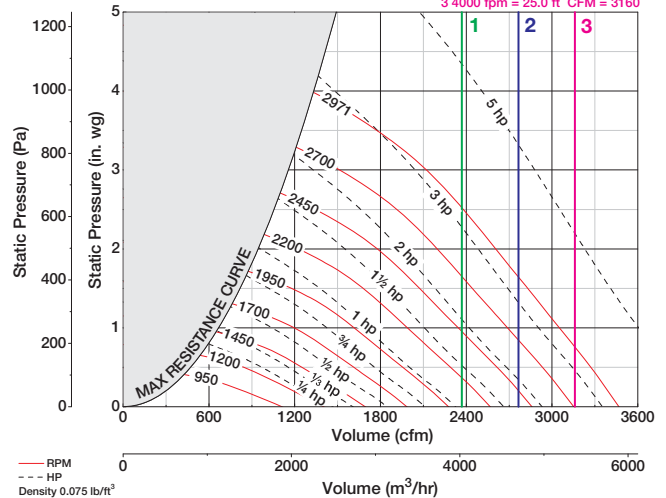

Performance certified for installation Type A: Free inlet, Free outlet. Rating Method "A" (Constant Speed, Transmission Loss Not Included). Power rating (Bhp) does not include transmission losses. Performance ratings do not include the effects of appurtenances (accessories). Plume rise calculated assuming a 10 mph crosswind, 3,000 ft/min. is the minimum recommended outlet velocity per ANSI Z9.5.

## 8-INCH NOZZLE

$$\%WOV = (CFM \times 100) / (RPM \times 1.10)$$

**Plume Rise**  
 1 3000 fpm = 18.0 ft CFM = 1050  
 2 3500 fpm = 19.0 ft CFM = 1225  
 3 4000 fpm = 20.0 ft CFM = 1400

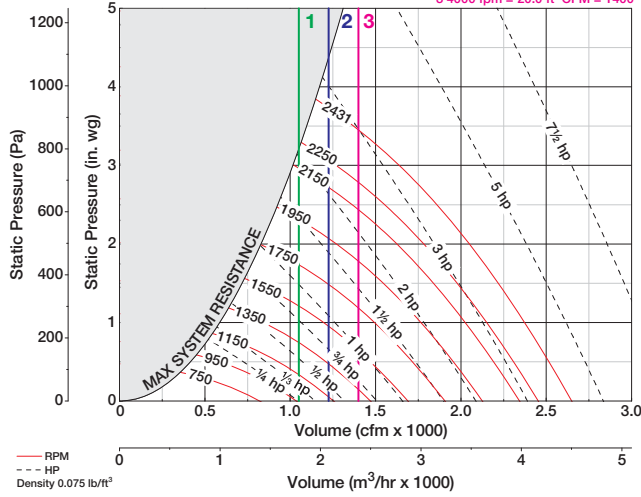

## 9-INCH NOZZLE

$$\%WOV = (CFM \times 100) / (RPM \times 1.30)$$

**Plume Rise**  
 1 3000 fpm = 19.0 ft CFM = 1320  
 2 3500 fpm = 20.0 ft CFM = 1540  
 3 4000 fpm = 21.0 ft CFM = 1760

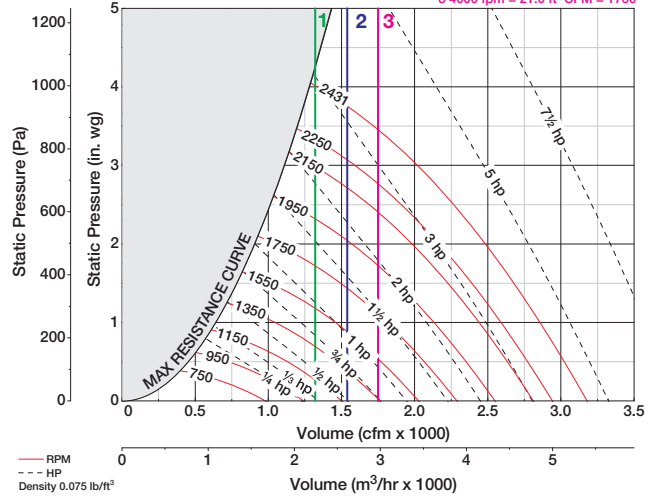

## 10-INCH NOZZLE

$$\%WOV = (CFM \times 100) / (RPM \times 1.51)$$

**Plume Rise**  
 1 3000 fpm = 20.0 ft CFM = 1650  
 2 3500 fpm = 21.0 ft CFM = 1925  
 3 4000 fpm = 22.0 ft CFM = 2200

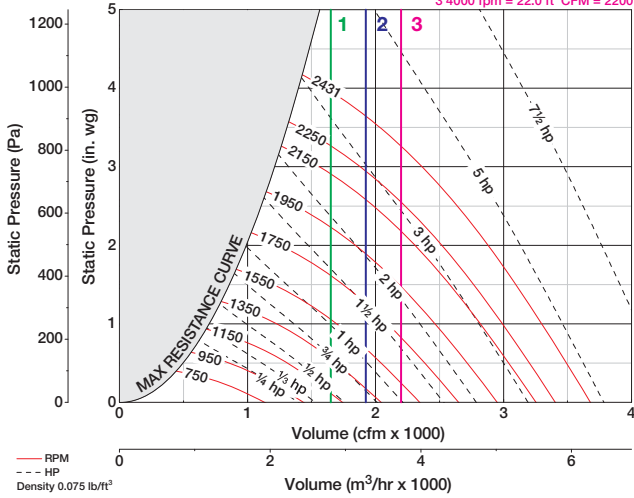

## 11-INCH NOZZLE

$$\%WOV = (CFM \times 100) / (RPM \times 1.71)$$

**Plume Rise**  
 1 3000 fpm = 20.0 ft CFM = 1950  
 2 3500 fpm = 22.0 ft CFM = 2310  
 3 4000 fpm = 24.0 ft CFM = 2640

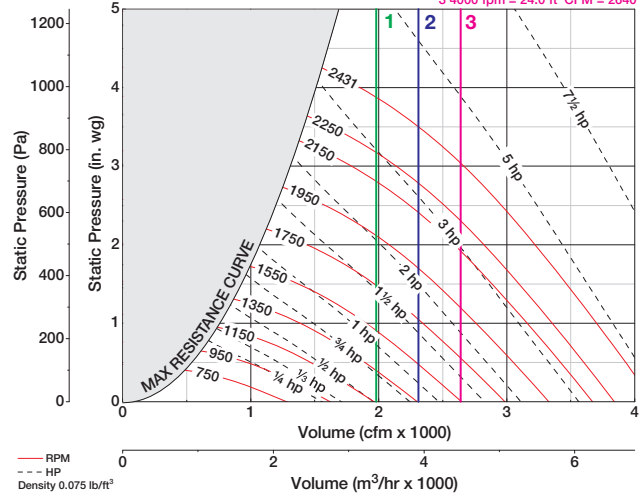

## 12-INCH NOZZLE

$$\%WOV = (CFM \times 100) / (RPM \times 1.88)$$

**Plume Rise**  
 1 3000 fpm = 21.0 ft CFM = 2370  
 2 3500 fpm = 23.0 ft CFM = 2765  
 3 4000 fpm = 25.0 ft CFM = 3160

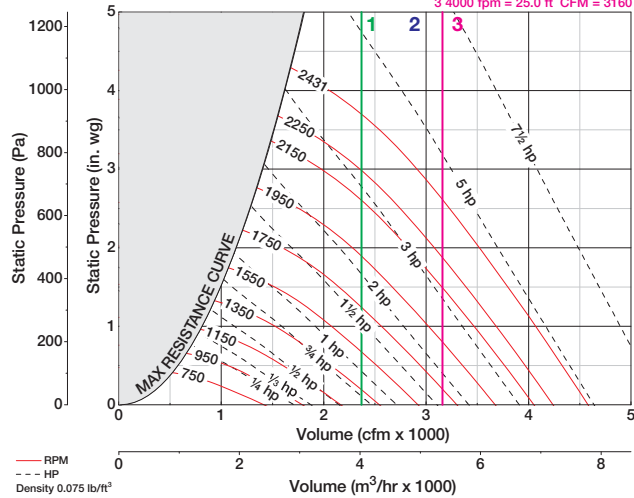

## 13-INCH NOZZLE

$$\%WOV = (CFM \times 100) / (RPM \times 2.04)$$

**Plume Rise**  
 1 3000 fpm = 22.0 ft CFM = 2760  
 2 3500 fpm = 24.0 ft CFM = 3220  
 3 4000 fpm = 26.0 ft CFM = 3680

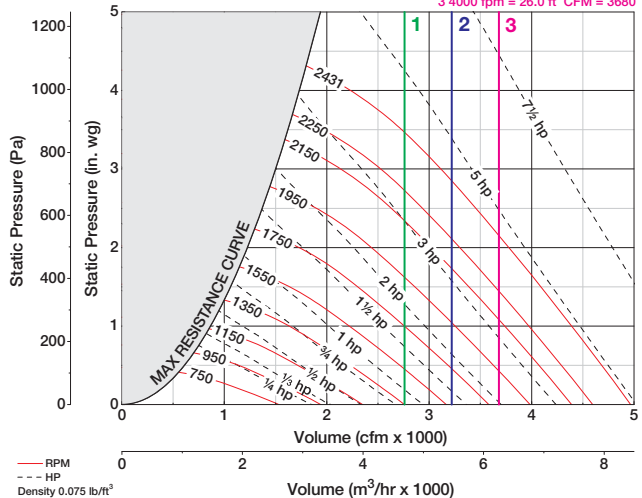

Performance certified is for installation Type A: Free inlet, Free outlet. Rating Method "A" (Constant Speed, Transmission Loss Not Included). Power rating (Bhp) does not include transmission losses. Performance ratings do not include the effects of appurtenances (accessories). Plume rise calculated assuming a 10 mph crosswind. 3,000 ft/min. is the minimum recommended outlet velocity per ANSI Z9.5.

## 14-INCH NOZZLE

$$\%WOV = (CFM \times 100) / (RPM \times 2.16)$$

Plume Rise  
 1 3000 fpm = 23.0 ft CFM = 3210  
 2 3500 fpm = 25.0 ft CFM = 3745  
 3 4000 fpm = 27.0 ft CFM = 4280

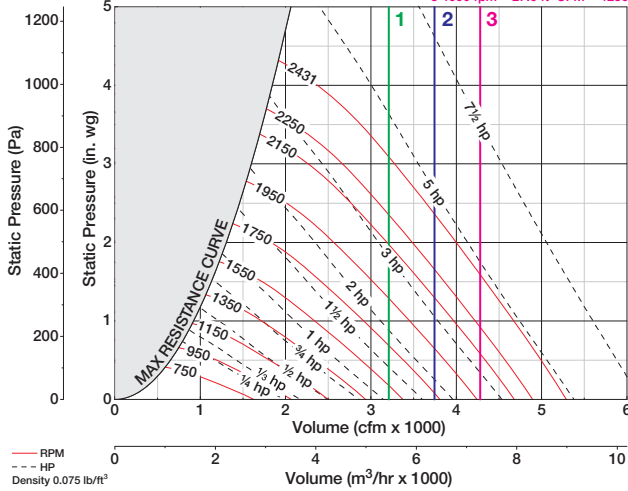

## 15-INCH NOZZLE

$$\%WOV = (CFM \times 100) / (RPM \times 2.30)$$

Plume Rise  
 1 3000 fpm = 24.0 ft CFM = 3690  
 2 3500 fpm = 26.0 ft CFM = 4305  
 3 4000 fpm = 28.0 ft CFM = 4920

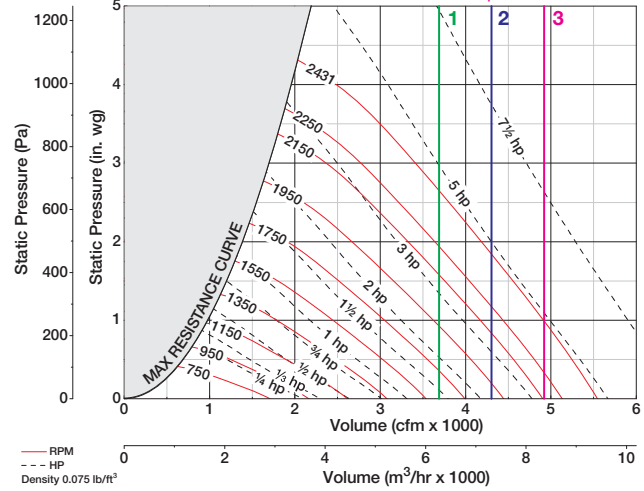

## 16-INCH NOZZLE

$$\%WOV = (CFM \times 100) / (RPM \times 2.38)$$

Plume Rise  
 1 3000 fpm = 25.0 ft CFM = 4200  
 2 3500 fpm = 27.0 ft CFM = 4900  
 3 4000 fpm = 29.0 ft CFM = 5600

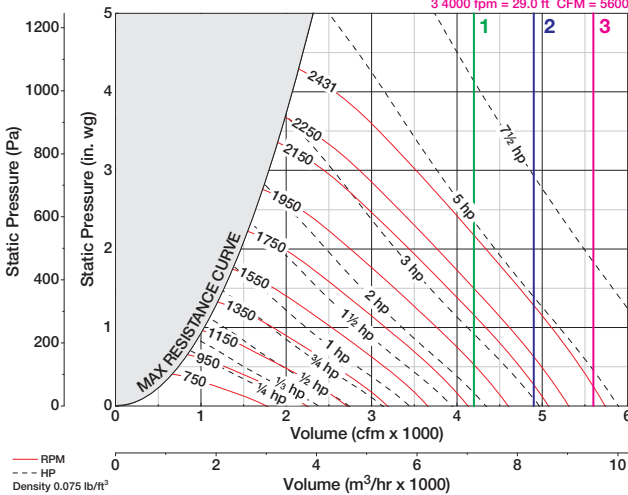

The Greenheck Vektor-H laboratory exhaust system can be applied to a single as well as multiple manifolded fume hoods, as shown below.

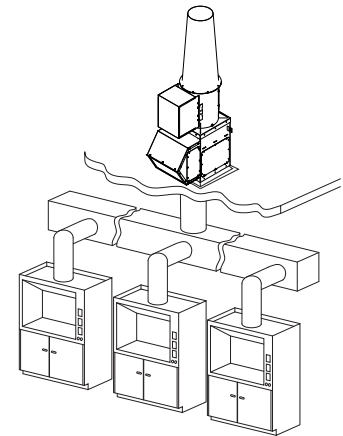

## Ease of Maintenance

The Greenheck Vektor-H laboratory exhaust system provides safe, easy inspection and maintenance of internal fan components. By removing one access panel, service to the fan wheel, shaft and bearing assembly is accomplished without removing the fan from the system.

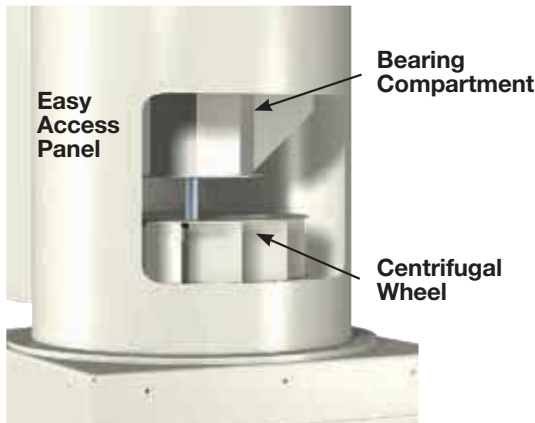

Performance certified is for installation Type A: Free inlet, Free outlet. Rating Method "A" (Constant Speed, Transmission Loss Not Included). Power rating (Bhp) does not include transmission losses. Performance ratings do not include the effects of appurtenances (accessories). Plume rise calculated assuming a 10 mph crosswind. 3,000 ft/min. is the minimum recommended outlet velocity per ANSI Z9.5.

## 9-INCH NOZZLE

$$\%WOV = (CFM \times 100) / (RPM \times 1.69)$$

**Plume Rise**  
 1 3000 fpm = 19.0 ft CFM = 1320  
 2 3500 fpm = 20.0 ft CFM = 1540  
 3 4000 fpm = 21.0 ft CFM = 1760

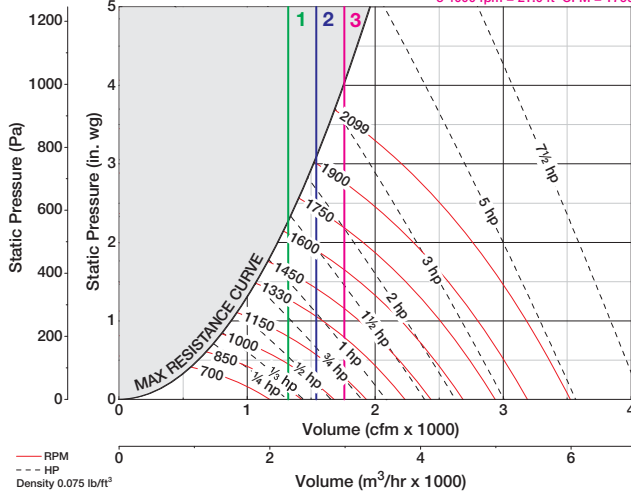

## 10-INCH NOZZLE

$$\%WOV = (CFM \times 100) / (RPM \times 1.97)$$

**Plume Rise**  
 1 3000 fpm = 20.0 ft CFM = 1650  
 2 3500 fpm = 21.0 ft CFM = 1925  
 3 4000 fpm = 22.0 ft CFM = 2200

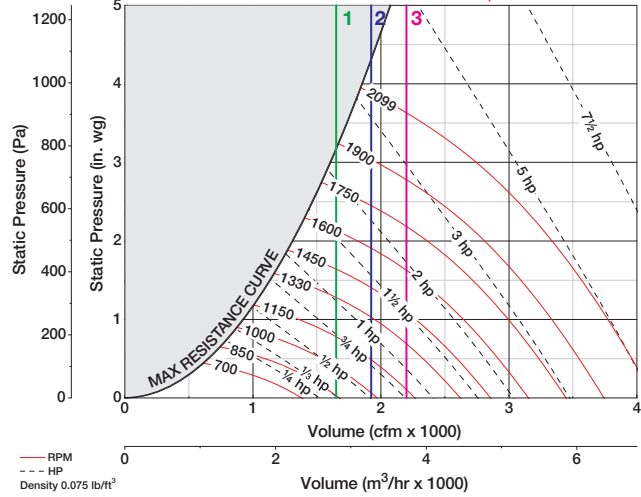

## 11-INCH NOZZLE

$$\%WOV = (CFM \times 100) / (RPM \times 2.24)$$

**Plume Rise**  
 1 3000 fpm = 20.0 ft CFM = 1980  
 2 3500 fpm = 22.0 ft CFM = 2310  
 3 4000 fpm = 24.0 ft CFM = 2640

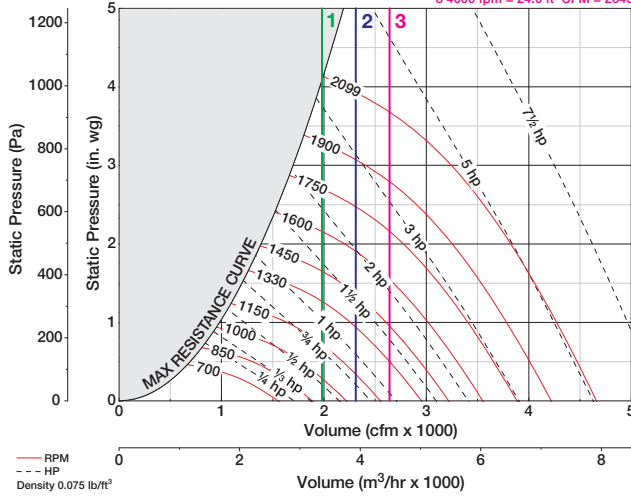

## 12-INCH NOZZLE

$$\%WOV = (CFM \times 100) / (RPM \times 2.43)$$

**Plume Rise**  
 1 3000 fpm = 21.0 ft CFM = 2370  
 2 3500 fpm = 23.0 ft CFM = 2765  
 3 4000 fpm = 25.0 ft CFM = 3160

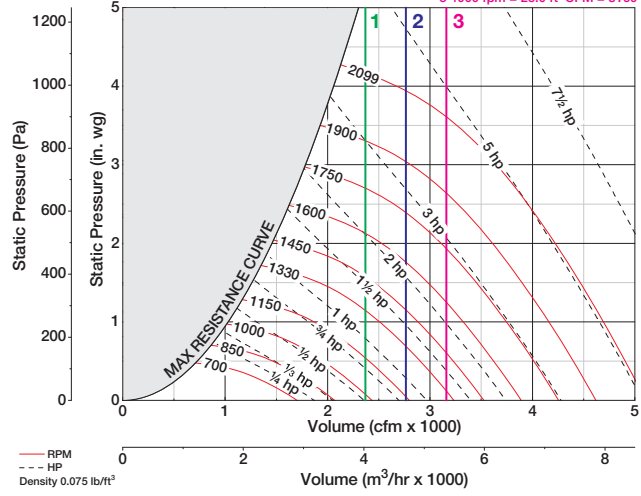

## 13-INCH NOZZLE

$$\%WOV = (CFM \times 100) / (RPM \times 2.62)$$

**Plume Rise**  
 1 3000 fpm = 22.0 ft CFM = 2760  
 2 3500 fpm = 24.0 ft CFM = 3220  
 3 4000 fpm = 26.0 ft CFM = 3680

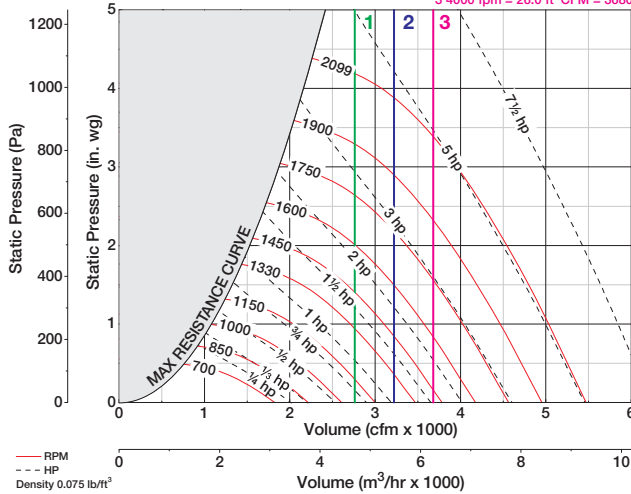

## 14-INCH NOZZLE

$$\%WOV = (CFM \times 100) / (RPM \times 2.77)$$

**Plume Rise**  
 1 3000 fpm = 23.0 ft CFM = 3210  
 2 3500 fpm = 25.0 ft CFM = 3745  
 3 4000 fpm = 27.0 ft CFM = 4280

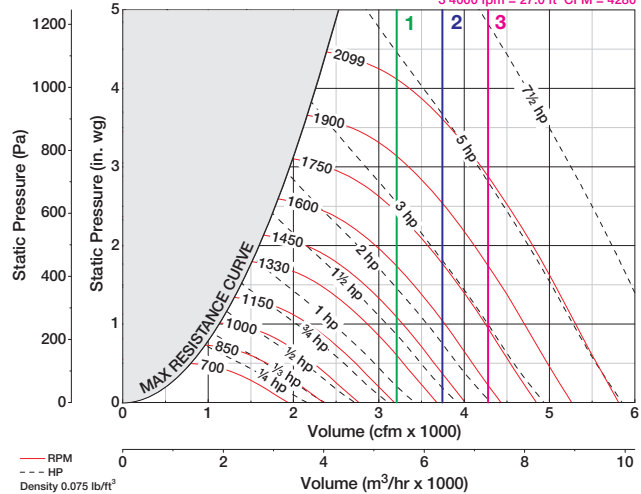

Performance certified is for installation Type A: Free inlet, Free outlet. Rating Method "A" (Constant Speed, Transmission Loss Not Included). Power rating (Bhp) does not include transmission losses. Performance ratings do not include the effects of appurtenances (accessories). Plume rise calculated assuming a 10 mph crosswind. 3,000 ft/min. is the minimum recommended outlet velocity per ANSI Z9.5.

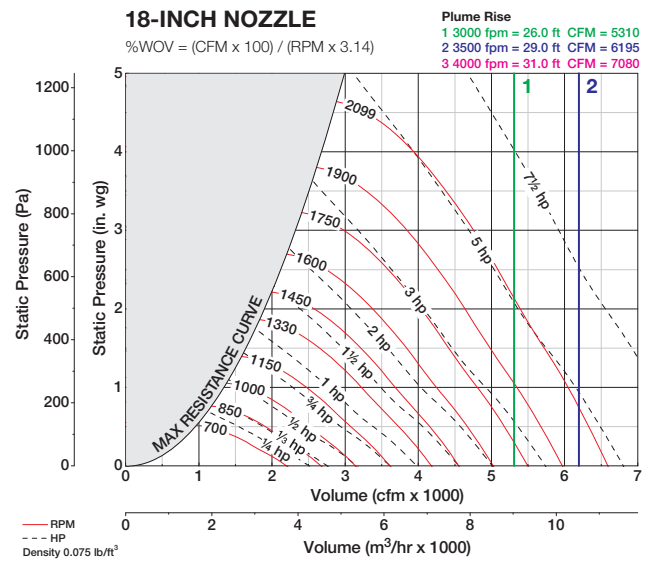
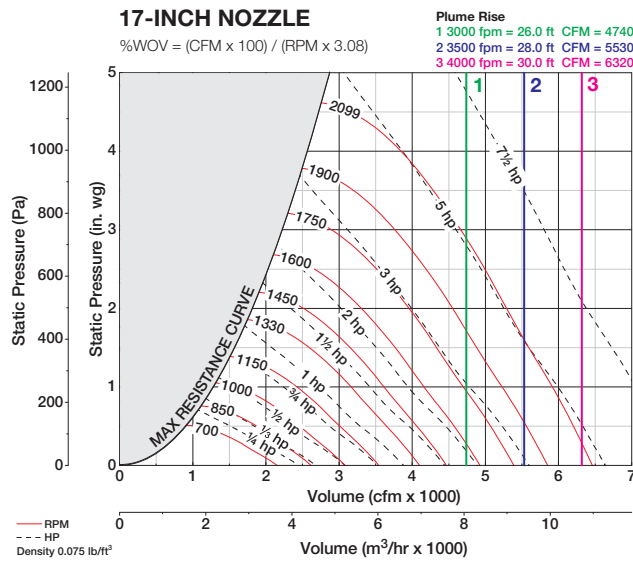
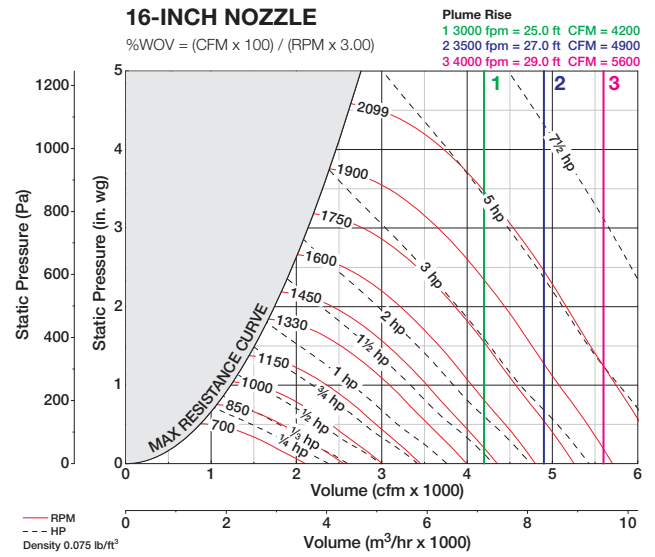
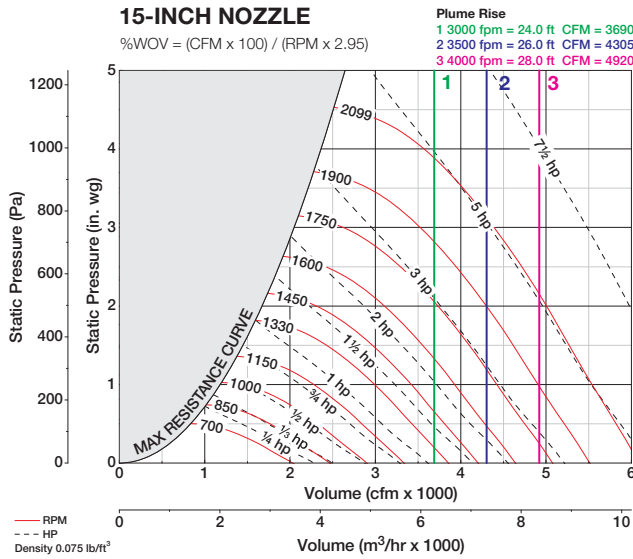

## Accessories

- Plenum
- Isolation Damper
- Bypass Air Damper
- Curb
- Disconnect
- Controls

## Vektor-H with UL 762

The Vektor-H is certified for applications where high temperature and grease are a hazard to the occupied space or outside environment. Choosing a Vektor-H with UL 762 can resolve any existing smoke or odor problems immediately.



## 10-INCH NOZZLE

$$\%WOV = (CFM \times 100) / (RPM \times 2.55)$$

**Plume Rise**  
 1 3000 fpm = 20.0 ft CFM = 1650  
 2 3500 fpm = 21.0 ft CFM = 1925  
 3 4000 fpm = 22.0 ft CFM = 2200

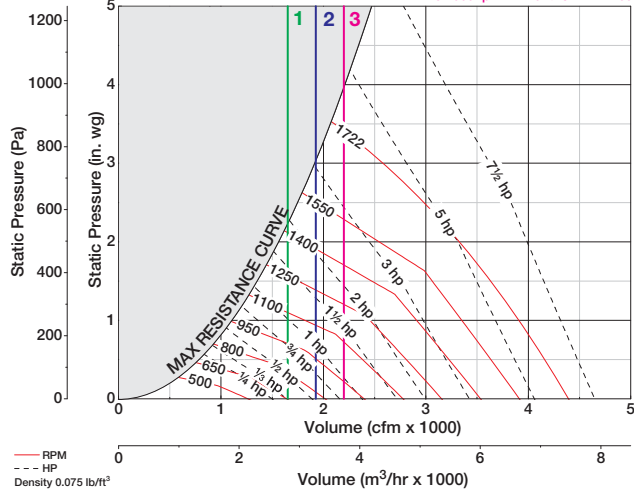

## 11-INCH NOZZLE

$$\%WOV = (CFM \times 100) / (RPM \times 3.05)$$

**Plume Rise**  
 1 3000 fpm = 20.0 ft CFM = 1980  
 2 3500 fpm = 22.0 ft CFM = 2310  
 3 4000 fpm = 24.0 ft CFM = 2640

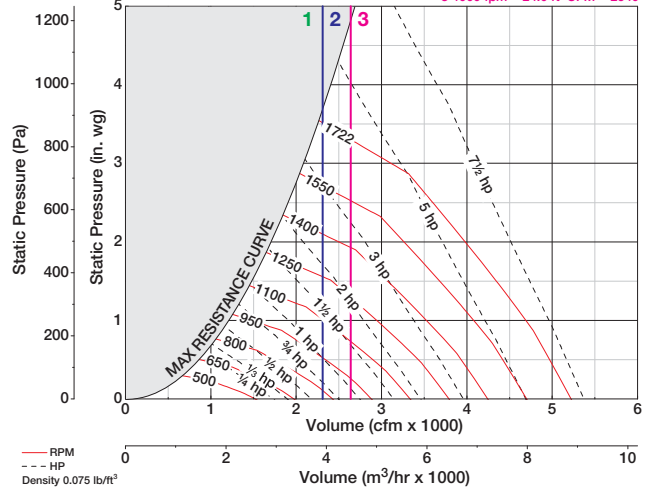

## 12-INCH NOZZLE

$$\%WOV = (CFM \times 100) / (RPM \times 3.52)$$

**Plume Rise**  
 1 3000 fpm = 21.0 ft CFM = 2370  
 2 3500 fpm = 23.0 ft CFM = 2765  
 3 4000 fpm = 25.0 ft CFM = 3160

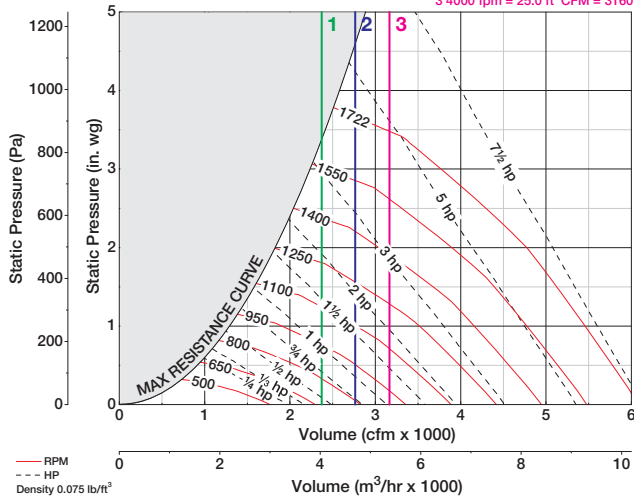

## 13-INCH NOZZLE

$$\%WOV = (CFM \times 100) / (RPM \times 4.00)$$

**Plume Rise**  
 1 3000 fpm = 22.0 ft CFM = 2760  
 2 3500 fpm = 24.0 ft CFM = 3220  
 3 4000 fpm = 26.0 ft CFM = 3680

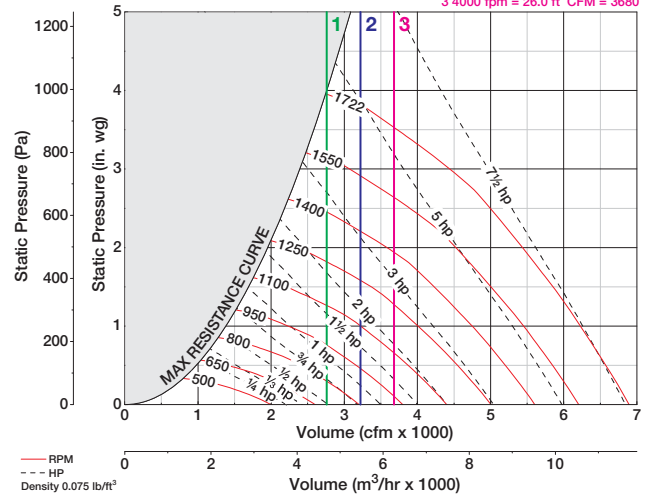

## 14-INCH NOZZLE

$$\%WOV = (CFM \times 100) / (RPM \times 4.39)$$

**Plume Rise**  
 1 3000 fpm = 23.0 ft CFM = 3210  
 2 3500 fpm = 25.0 ft CFM = 3745  
 3 4000 fpm = 27.0 ft CFM = 4280

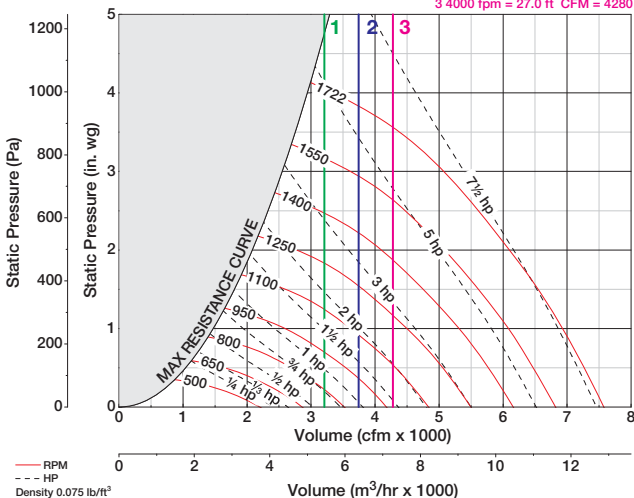

## 15-INCH NOZZLE

$$\%WOV = (CFM \times 100) / (RPM \times 4.74)$$

**Plume Rise**  
 1 3000 fpm = 24.0 ft CFM = 3690  
 2 3500 fpm = 26.0 ft CFM = 4305  
 3 4000 fpm = 28.0 ft CFM = 4920

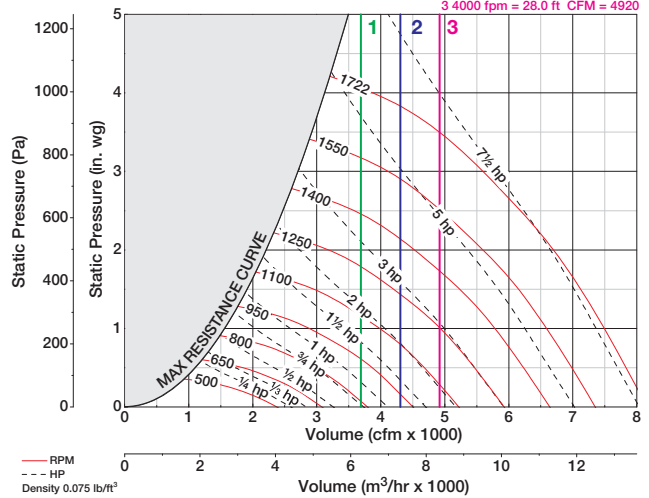

Performance certified is for installation Type A: Free inlet, Free outlet. Rating Method "A" (Constant Speed, Transmission Loss Not Included). Power rating (Bhp) does not include transmission losses. Performance ratings do not include the effects of appurtenances (accessories). Plume rise calculated assuming a 10 mph crosswind, 3,000 ft/min. is the minimum recommended outlet velocity per ANSI Z9.5.

## 16-INCH NOZZLE

$$\%WOV = (CFM \times 100) / (RPM \times 5.03)$$

### Plume Rise

- 1 3000 fpm = 25.0 ft CFM = 4200
- 2 3500 fpm = 27.0 ft CFM = 4900
- 3 4000 fpm = 29.0 ft CFM = 5600

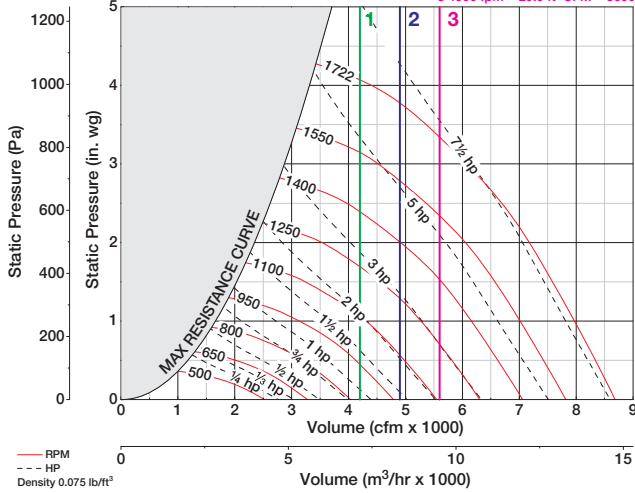

## 17-INCH NOZZLE

$$\%WOV = (CFM \times 100) / (RPM \times 5.29)$$

### Plume Rise

- 1 3000 fpm = 26.0 ft CFM = 4740
- 2 3500 fpm = 28.0 ft CFM = 5530
- 3 4000 fpm = 30.0 ft CFM = 6320

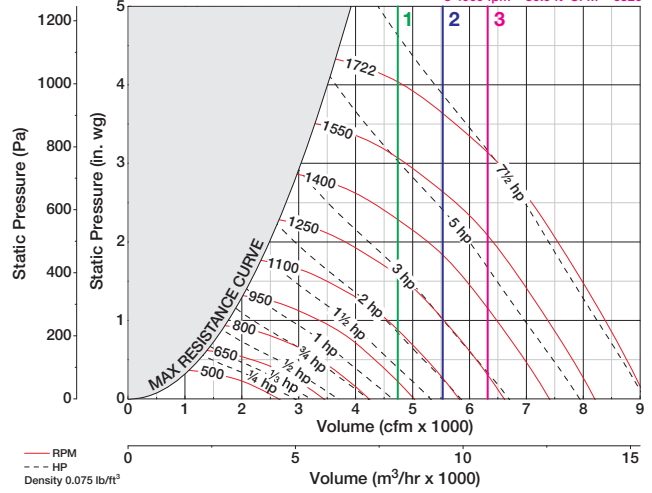

## 18-INCH NOZZLE

$$\%WOV = (CFM \times 100) / (RPM \times 5.48)$$

### Plume Rise

- 1 3000 fpm = 26.0 ft CFM = 5310
- 2 3500 fpm = 29.0 ft CFM = 6195
- 3 4000 fpm = 31.0 ft CFM = 7080

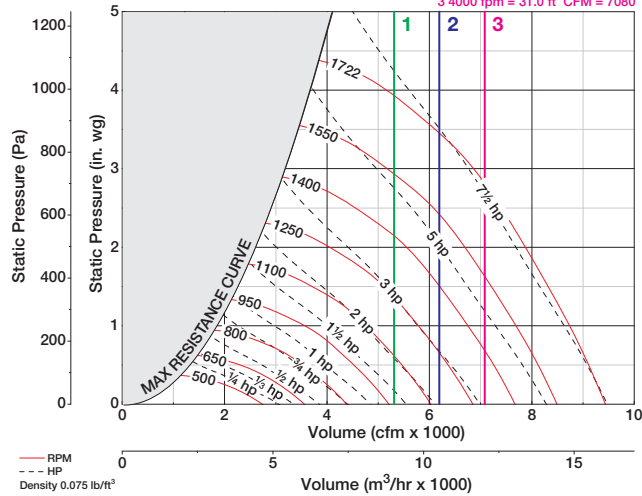

## 19-INCH NOZZLE

$$\%WOV = (CFM \times 100) / (RPM \times 5.61)$$

### Plume Rise

- 1 3000 fpm = 27.0 ft CFM = 5910
- 2 3500 fpm = 30.0 ft CFM = 6895
- 3 4000 fpm = 33.0 ft CFM = 7880

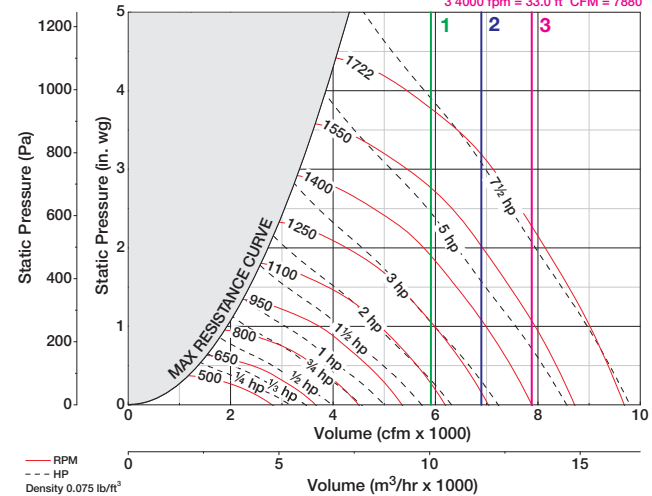

## 20-INCH NOZZLE

$$\%WOV = (CFM \times 100) / (RPM \times 5.74)$$

### Plume Rise

- 1 3000 fpm = 28.0 ft CFM = 6540
- 2 3500 fpm = 31.0 ft CFM = 7630
- 3 4000 fpm = 34.0 ft CFM = 8720

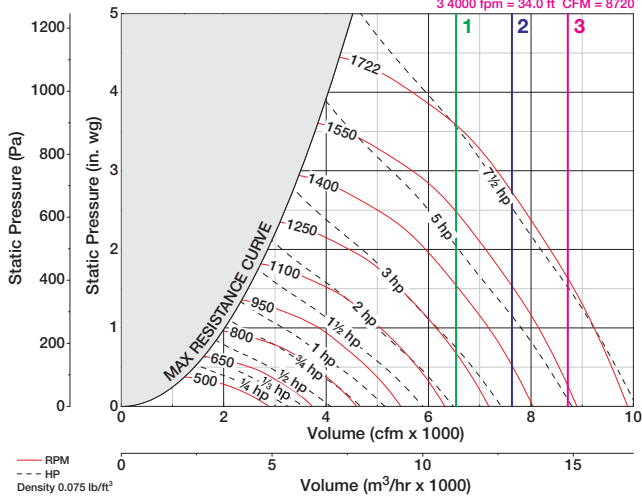

## 22-INCH NOZZLE

$$\%WOV = (CFM \times 100) / (RPM \times 5.88)$$

### Plume Rise

- 1 3000 fpm = 30.0 ft CFM = 7920
- 2 3500 fpm = 33.0 ft CFM = 9240
- 3 4000 fpm = 36.0 ft CFM = 10560

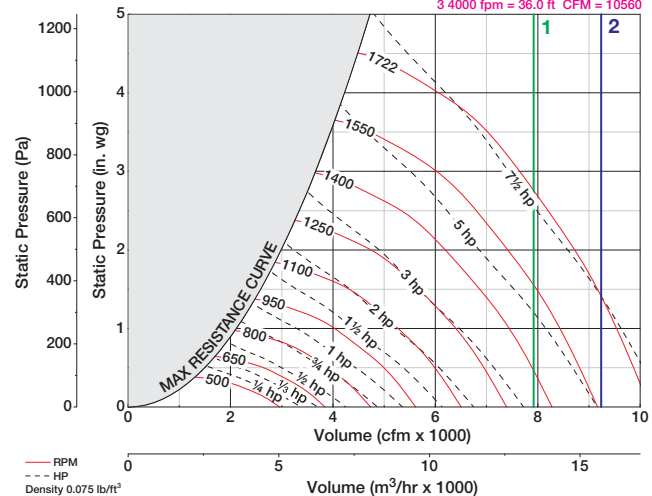

Performance certified is for installation Type A: Free inlet, Free outlet. Rating Method "A" (Constant Speed, Transmission Loss Not Included). Power rating (Bhp) does not include transmission losses. Performance ratings do not include the effects of appurtenances (accessories). Plume rise calculated assuming a 10 mph crosswind. 3,000 ft/min. is the minimum recommended outlet velocity per ANSI Z9.5.

## 13-INCH NOZZLE

$$\%WOV = (CFM \times 100) / (RPM \times 5.15)$$

**Plume Rise**  
 1 3000 fpm = 22.0 ft CFM = 2760  
 2 3500 fpm = 24.0 ft CFM = 3220  
 3 4000 fpm = 26.0 ft CFM = 3680

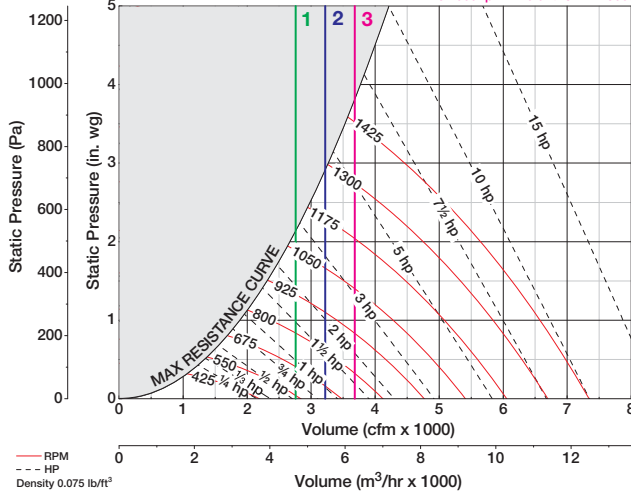

## 14-INCH NOZZLE

$$\%WOV = (CFM \times 100) / (RPM \times 5.79)$$

**Plume Rise**  
 1 3000 fpm = 23.0 ft CFM = 3210  
 2 3500 fpm = 25.0 ft CFM = 3745  
 3 4000 fpm = 27.0 ft CFM = 4280

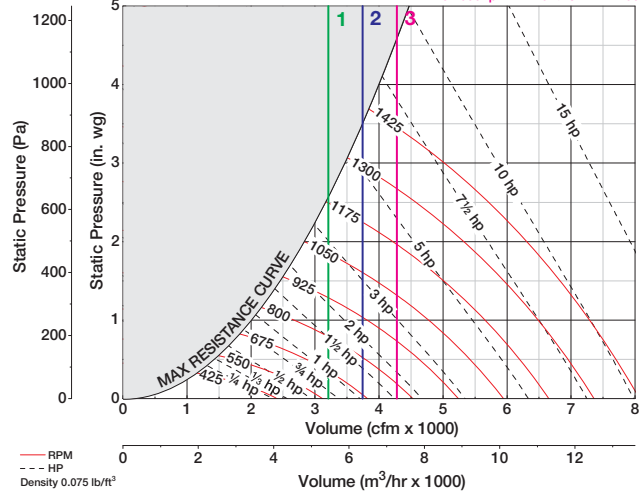

## 15-INCH NOZZLE

$$\%WOV = (CFM \times 100) / (RPM \times 6.42)$$

**Plume Rise**  
 1 3000 fpm = 24.0 ft CFM = 3690  
 2 3500 fpm = 26.0 ft CFM = 4305  
 3 4000 fpm = 28.0 ft CFM = 4920

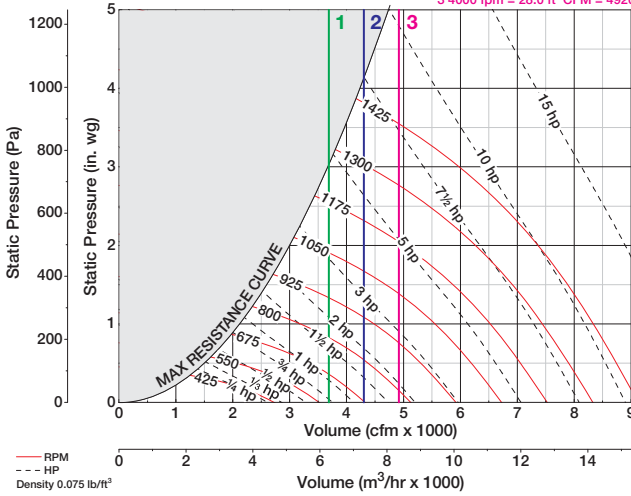

## 16-INCH NOZZLE

$$\%WOV = (CFM \times 100) / (RPM \times 6.95)$$

**Plume Rise**  
 1 3000 fpm = 25.0 ft CFM = 4200  
 2 3500 fpm = 27.0 ft CFM = 4900  
 3 4000 fpm = 29.0 ft CFM = 5600

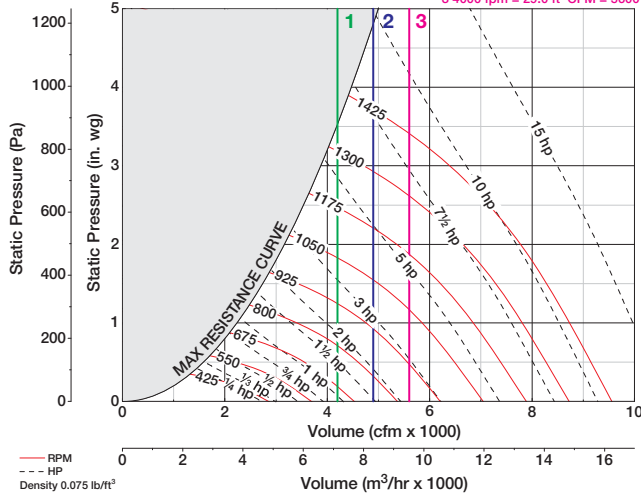

## 17-INCH NOZZLE

$$\%WOV = (CFM \times 100) / (RPM \times 7.48)$$

**Plume Rise**  
 1 3000 fpm = 26.0 ft CFM = 4740  
 2 3500 fpm = 28.0 ft CFM = 5530  
 3 4000 fpm = 30.0 ft CFM = 6320

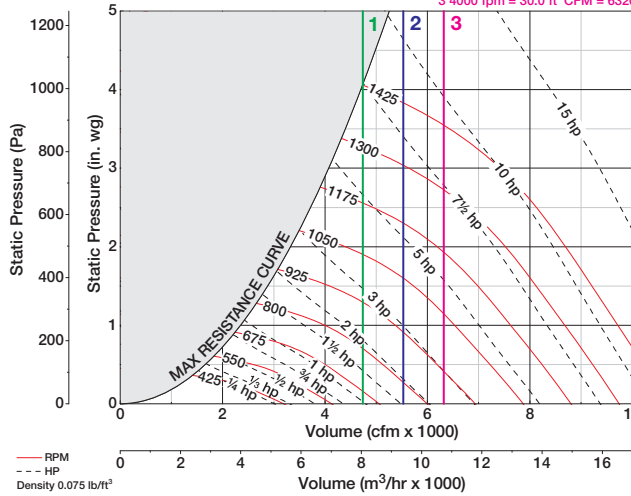

## 18-INCH NOZZLE

$$\%WOV = (CFM \times 100) / (RPM \times 8.07)$$

**Plume Rise**  
 1 3000 fpm = 26.0 ft CFM = 5310  
 2 3500 fpm = 29.0 ft CFM = 6195  
 3 4000 fpm = 31.0 ft CFM = 7080

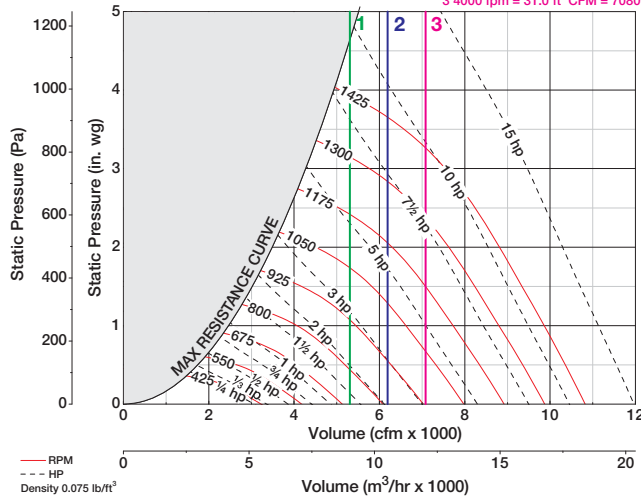



## 19-INCH NOZZLE

$$\%WOV = (CFM \times 100) / (RPM \times 8.35)$$

**Plume Rise**  
 1 3000 fpm = 27.0 ft CFM = 5910  
 2 3500 fpm = 30.0 ft CFM = 6895  
 3 4000 fpm = 33.0 ft CFM = 7880

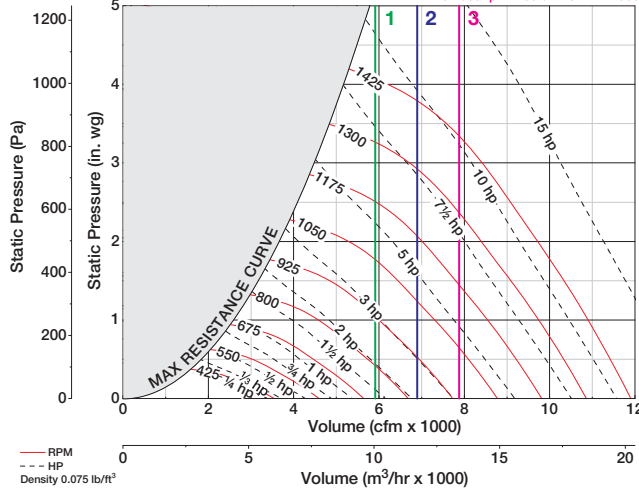

## 20-INCH NOZZLE

$$\%WOV = (CFM \times 100) / (RPM \times 8.77)$$

**Plume Rise**  
 1 3000 fpm = 28.0 ft CFM = 6540  
 2 3500 fpm = 31.0 ft CFM = 7630  
 3 4000 fpm = 34.0 ft CFM = 8720

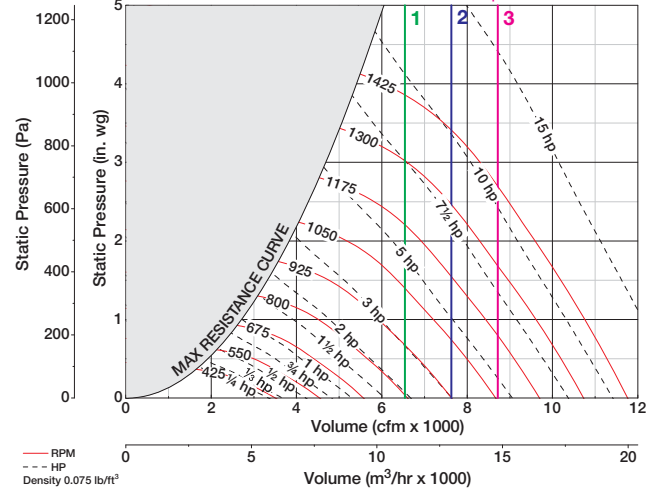

## 22-INCH NOZZLE

$$\%WOV = (CFM \times 100) / (RPM \times 9.19)$$

**Plume Rise**  
 1 3000 fpm = 30.0 ft CFM = 7920  
 2 3500 fpm = 33.0 ft CFM = 9240  
 3 4000 fpm = 36.0 ft CFM = 10560

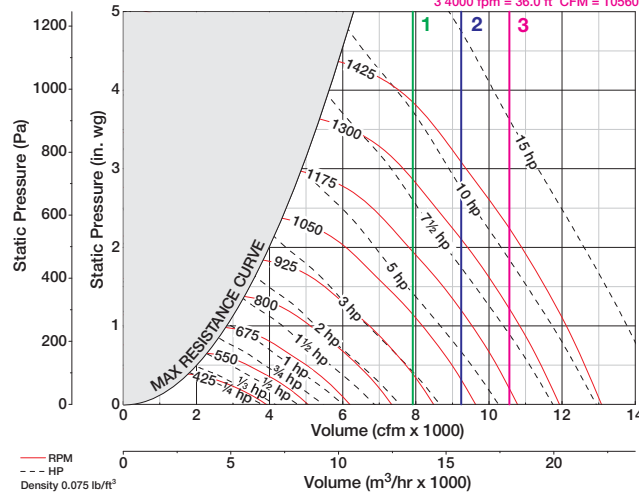

## 24-INCH NOZZLE

$$\%WOV = (CFM \times 100) / (RPM \times 9.54)$$

**Plume Rise**  
 1 3000 fpm = 31.0 ft CFM = 9420  
 2 3500 fpm = 35.0 ft CFM = 10990  
 3 4000 fpm = 38.0 ft CFM = 12560

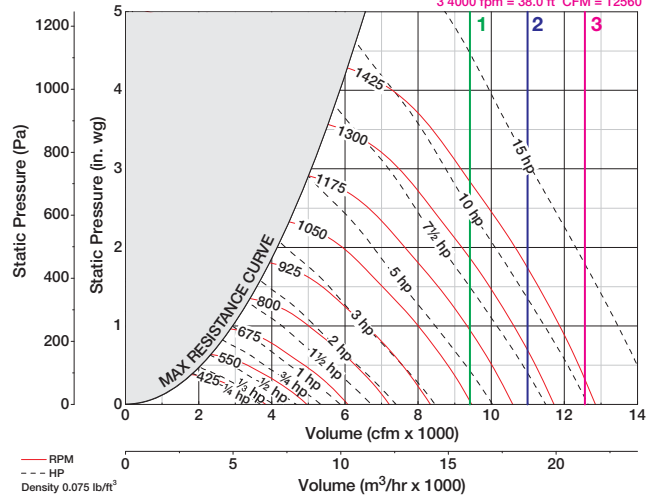

## 26-INCH NOZZLE

$$\%WOV = (CFM \times 100) / (RPM \times 9.82)$$

**Plume Rise**  
 1 3000 fpm = 33.0 ft CFM = 11070  
 2 3500 fpm = 37.0 ft CFM = 12915  
 3 4000 fpm = 41.0 ft CFM = 14760

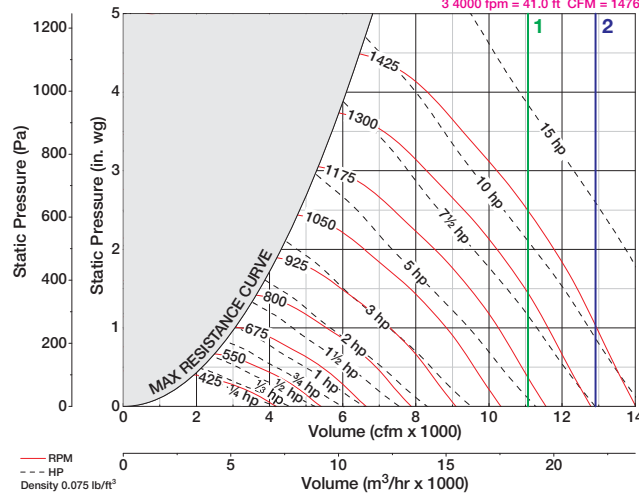

Vektor-H System Approach



Component Approach



Field fabricated duct Leaky duct seams

Performance certified for installation Type A: Free inlet, Free outlet. Rating Method "A" (Constant Speed, Transmission Loss Not Included). Power rating (Bhp) does not include transmission losses. Performance ratings do not include the effects of appurtenances (accessories). Plume rise calculated assuming a 10 mph crosswind. 3,000 ft/min. is the minimum recommended outlet velocity per ANSI Z9.5.

## 15-INCH NOZZLE

$$\%WOV = (CFM \times 100) / (RPM \times 7.51)$$

**Plume Rise**  
 1 3000 fpm = 24.0 ft CFM = 3690  
 2 3500 fpm = 26.0 ft CFM = 4305  
 3 4000 fpm = 28.0 ft CFM = 4920

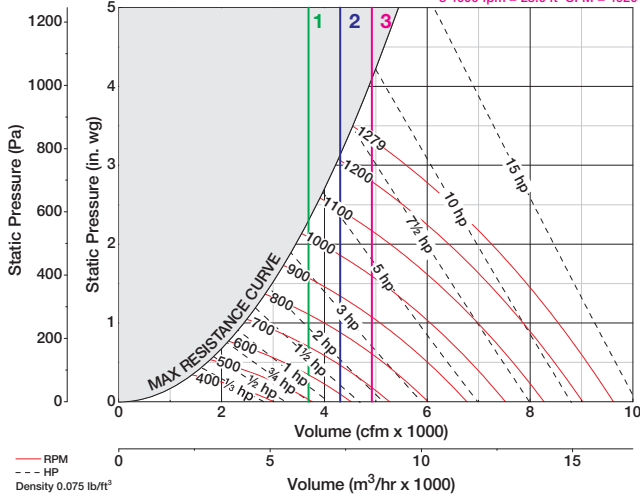

## 16-INCH NOZZLE

$$\%WOV = (CFM \times 100) / (RPM \times 8.41)$$

**Plume Rise**  
 1 3000 fpm = 25.0 ft CFM = 4200  
 2 3500 fpm = 27.0 ft CFM = 4900  
 3 4000 fpm = 29.0 ft CFM = 5600

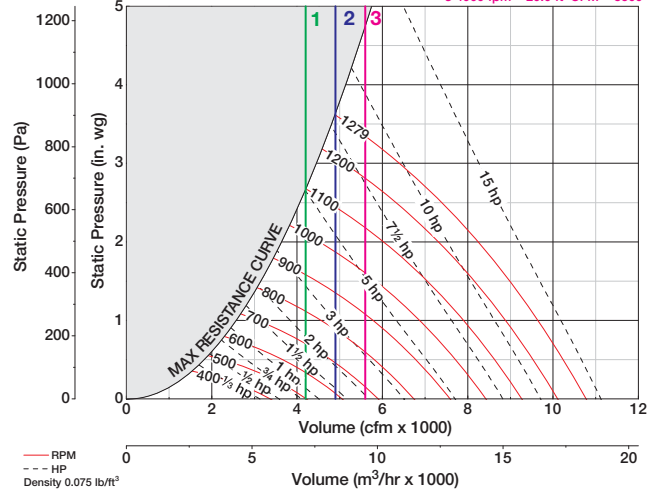

## 17-INCH NOZZLE

$$\%WOV = (CFM \times 100) / (RPM \times 9.23)$$

**Plume Rise**  
 1 3000 fpm = 26.0 ft CFM = 4740  
 2 3500 fpm = 28.0 ft CFM = 5530  
 3 4000 fpm = 30.0 ft CFM = 6320

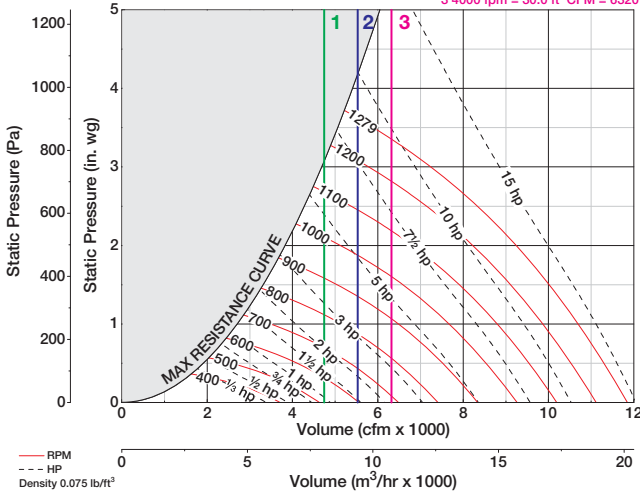

## 18-INCH NOZZLE

$$\%WOV = (CFM \times 100) / (RPM \times 10.01)$$

**Plume Rise**  
 1 3000 fpm = 26.0 ft CFM = 5310  
 2 3500 fpm = 29.0 ft CFM = 6195  
 3 4000 fpm = 31.0 ft CFM = 7080

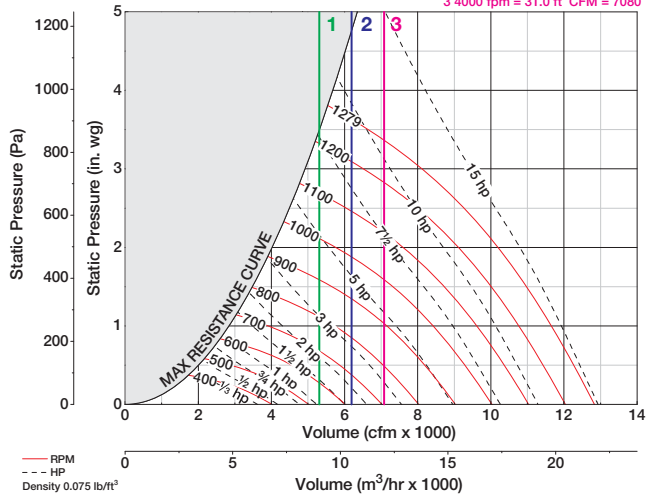

## 19-INCH NOZZLE

$$\%WOV = (CFM \times 100) / (RPM \times 10.36)$$

**Plume Rise**  
 1 3000 fpm = 27.0 ft CFM = 5910  
 2 3500 fpm = 30.0 ft CFM = 6895  
 3 4000 fpm = 33.0 ft CFM = 7880

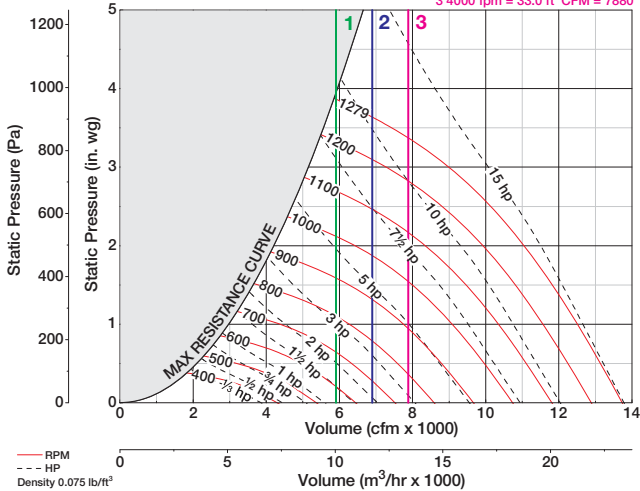

## 20-INCH NOZZLE

$$\%WOV = (CFM \times 100) / (RPM \times 11.21)$$

**Plume Rise**  
 1 3000 fpm = 28.0 ft CFM = 6540  
 2 3500 fpm = 31.0 ft CFM = 7630  
 3 4000 fpm = 34.0 ft CFM = 8720

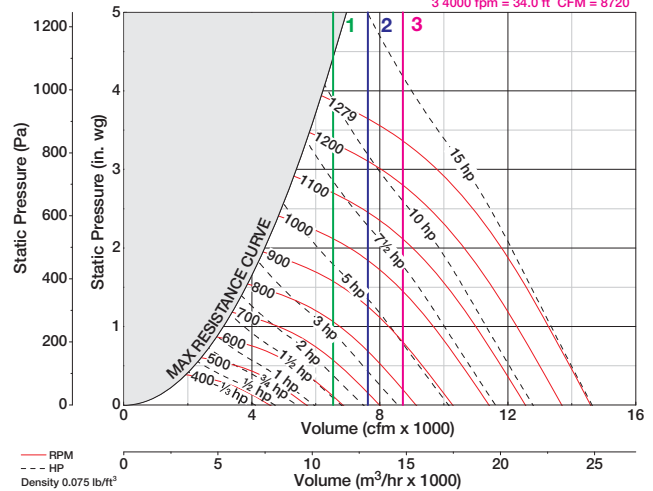

Performance certified is for installation Type A: Free inlet, Free outlet. Rating Method "A" (Constant Speed, Transmission Loss Not Included). Power rating (Bhp) does not include transmission losses. Performance ratings do not include the effects of appurtenances (accessories). Plume rise calculated assuming a 10 mph crosswind. 3,000 ft/min. is the minimum recommended outlet velocity per ANSI Z9.5.

## 22-INCH NOZZLE

$$\%WOV = (CFM \times 100) / (RPM \times 12.64)$$

**Plume Rise**  
 1 3000 fpm = 30.0 ft CFM = 7920  
 2 3500 fpm = 33.0 ft CFM = 9240  
 3 4000 fpm = 36.0 ft CFM = 10560

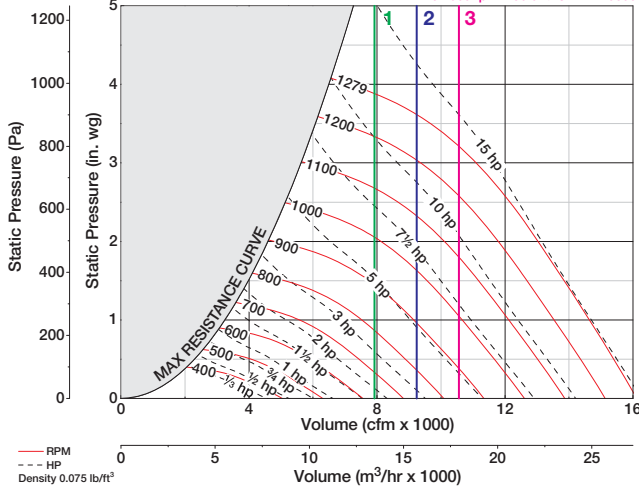

## 24-INCH NOZZLE

$$\%WOV = (CFM \times 100) / (RPM \times 13.49)$$

**Plume Rise**  
 1 3000 fpm = 31.0 ft CFM = 9420  
 2 3500 fpm = 35.0 ft CFM = 10990  
 3 4000 fpm = 38.0 ft CFM = 12560

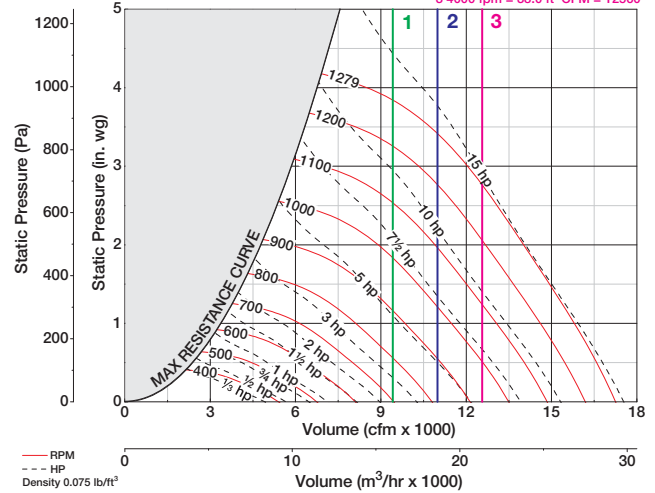

## 26-INCH NOZZLE

$$\%WOV = (CFM \times 100) / (RPM \times 14.07)$$

**Plume Rise**  
 1 3000 fpm = 33.0 ft CFM = 11070  
 2 3500 fpm = 37.0 ft CFM = 12915  
 3 4000 fpm = 41.0 ft CFM = 14760

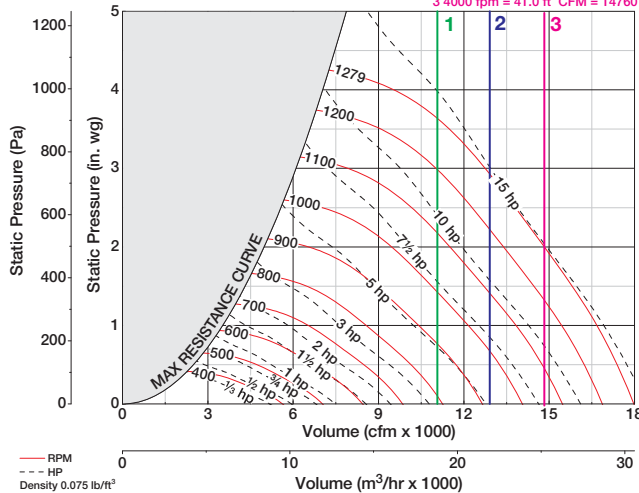

## 27-INCH NOZZLE

$$\%WOV = (CFM \times 100) / (RPM \times 14.31)$$

**Plume Rise**  
 1 3000 fpm = 34.0 ft CFM = 11940  
 2 3500 fpm = 38.0 ft CFM = 13930  
 3 4000 fpm = 42.0 ft CFM = 15920

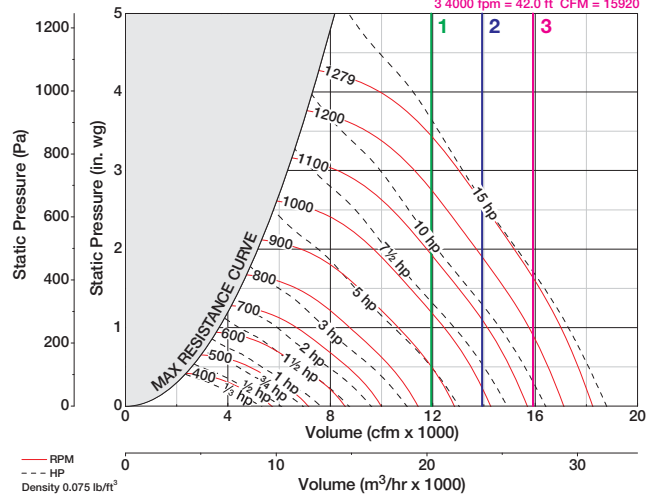

## 28-INCH NOZZLE

$$\%WOV = (CFM \times 100) / (RPM \times 14.39)$$

**Plume Rise**  
 1 3000 fpm = 35.0 ft CFM = 12840  
 2 3500 fpm = 39.0 ft CFM = 14980  
 3 4000 fpm = 43.0 ft CFM = 17120

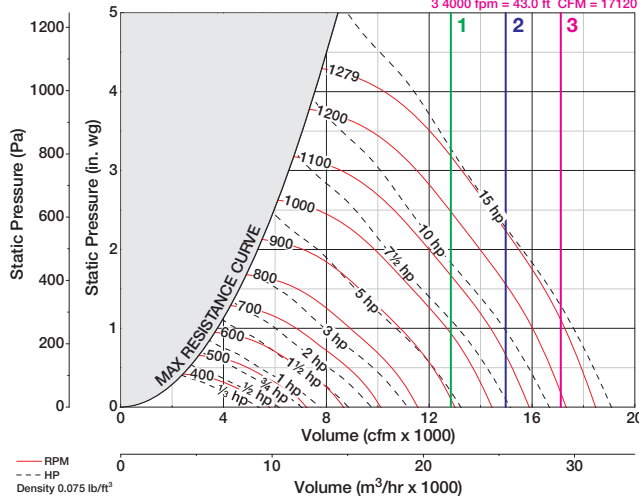

## 30-INCH NOZZLE

$$\%WOV = (CFM \times 100) / (RPM \times 14.70)$$

**Plume Rise**  
 1 3000 fpm = 37.0 ft CFM = 14730  
 2 3500 fpm = 41.0 ft CFM = 17185  
 3 4000 fpm = 45.0 ft CFM = 19640

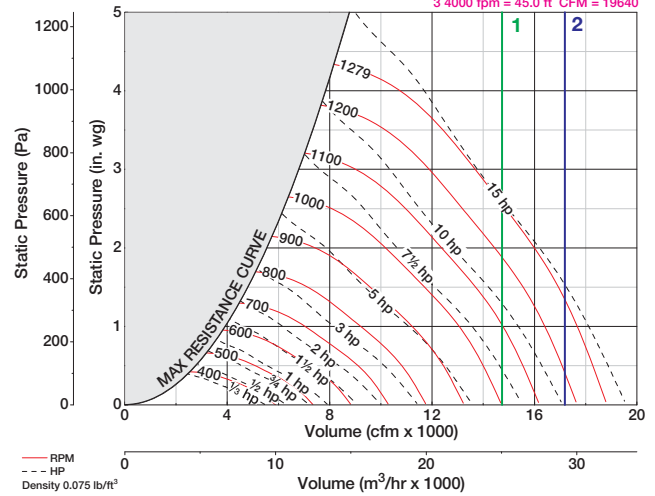

Performance certified is for installation Type A: Free inlet, Free outlet. Rating Method "A" (Constant Speed, Transmission Loss Not Included). Power rating (Bhp) does not include transmission losses. Performance ratings do not include the effects of appurtenances (accessories). Plume rise calculated assuming a 10 mph crosswind. 3,000 ft/min. is the minimum recommended outlet velocity per ANSI Z9.5.

## 18-INCH NOZZLE

$$\%WOV = (CFM \times 100) / (RPM \times 12.94)$$

**Plume Rise**  
 1 3000 fpm = 26.0 ft CFM = 5310  
 2 3500 fpm = 29.0 ft CFM = 6195  
 3 4000 fpm = 31.0 ft CFM = 7080

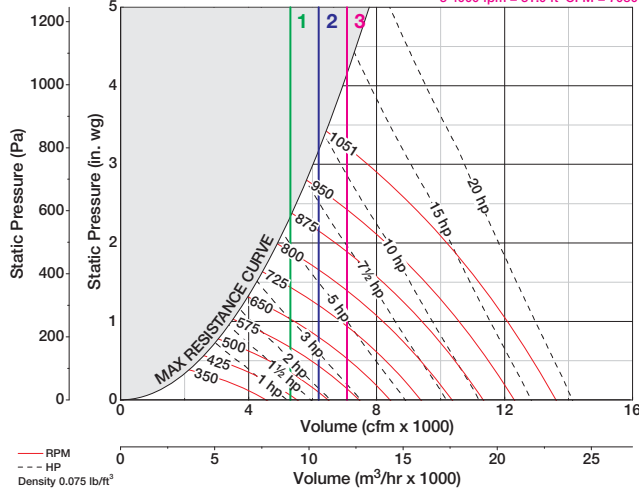

## 19-INCH NOZZLE

$$\%WOV = (CFM \times 100) / (RPM \times 15.03)$$

**Plume Rise**  
 1 3000 fpm = 27.0 ft CFM = 5910  
 2 3500 fpm = 30.0 ft CFM = 6895  
 3 4000 fpm = 33.0 ft CFM = 7880

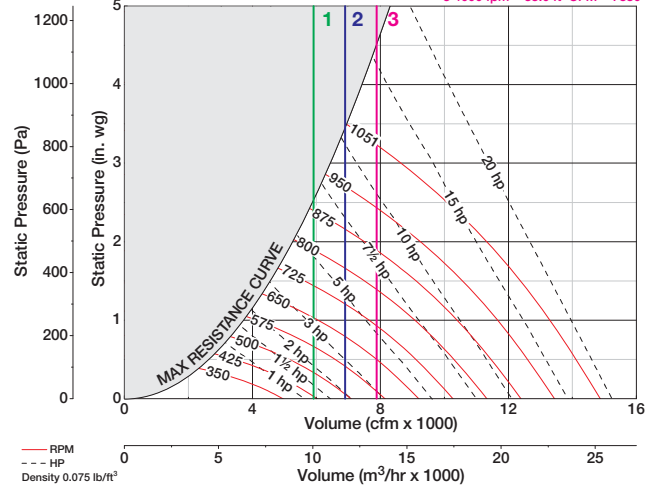

## 20-INCH NOZZLE

$$\%WOV = (CFM \times 100) / (RPM \times 15.41)$$

**Plume Rise**  
 1 3000 fpm = 28.0 ft CFM = 6540  
 2 3500 fpm = 31.0 ft CFM = 7630  
 3 4000 fpm = 34.0 ft CFM = 8720

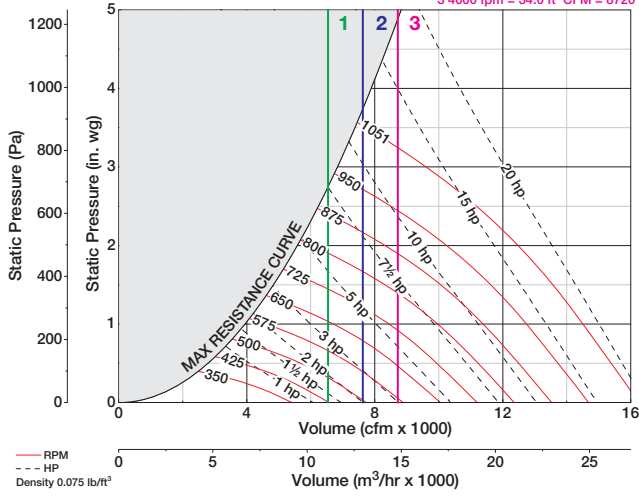

## 22-INCH NOZZLE

$$\%WOV = (CFM \times 100) / (RPM \times 17.89)$$

**Plume Rise**  
 1 3000 fpm = 30.0 ft CFM = 7920  
 2 3500 fpm = 33.0 ft CFM = 9240  
 3 4000 fpm = 36.0 ft CFM = 10560

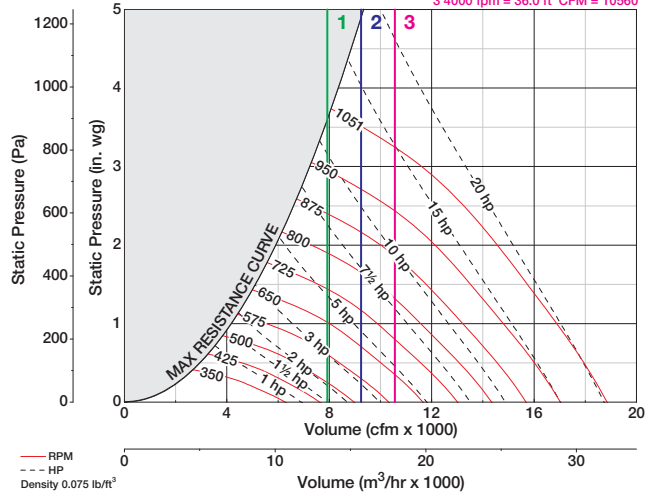

## 24-INCH NOZZLE

$$\%WOV = (CFM \times 100) / (RPM \times 19.79)$$

**Plume Rise**  
 1 3000 fpm = 31.0 ft CFM = 9420  
 2 3500 fpm = 35.0 ft CFM = 10990  
 3 4000 fpm = 38.0 ft CFM = 12560

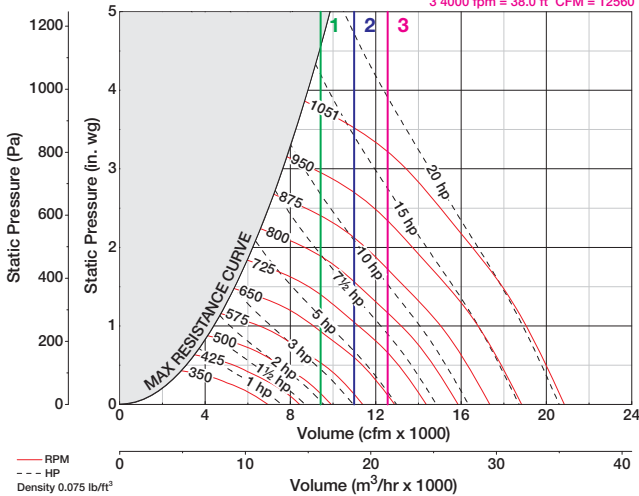

## 26-INCH NOZZLE

$$\%WOV = (CFM \times 100) / (RPM \times 21.65)$$

**Plume Rise**  
 1 3000 fpm = 33.0 ft CFM = 11070  
 2 3500 fpm = 37.0 ft CFM = 12915  
 3 4000 fpm = 41.0 ft CFM = 14760

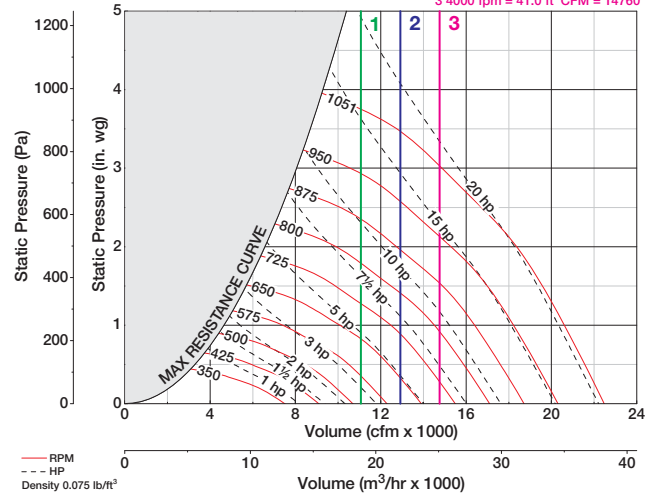

Performance certified is for installation Type A: Free inlet, Free outlet. Rating Method "A" (Constant Speed, Transmission Loss Not Included). Power rating (Bhp) does not include transmission losses. Performance ratings do not include the effects of appurtenances (accessories). Plume rise calculated assuming a 10 mph crosswind. 3,000 ft/min. is the minimum recommended outlet velocity per ANSI Z9.5.

## 27-INCH NOZZLE

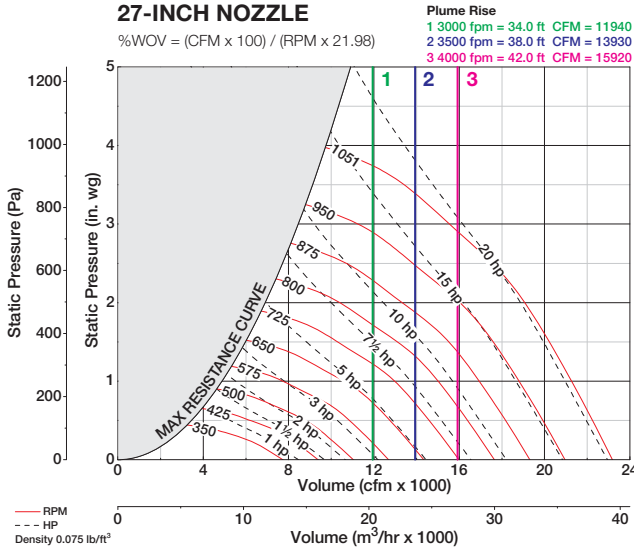

## 28-INCH NOZZLE

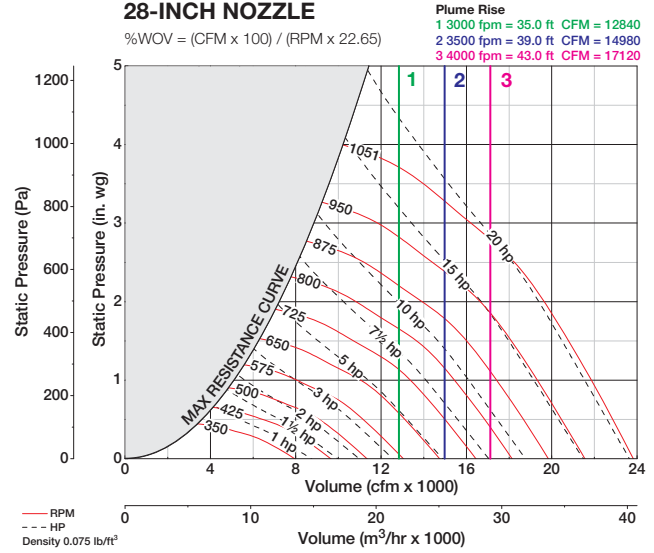

## 30-INCH NOZZLE

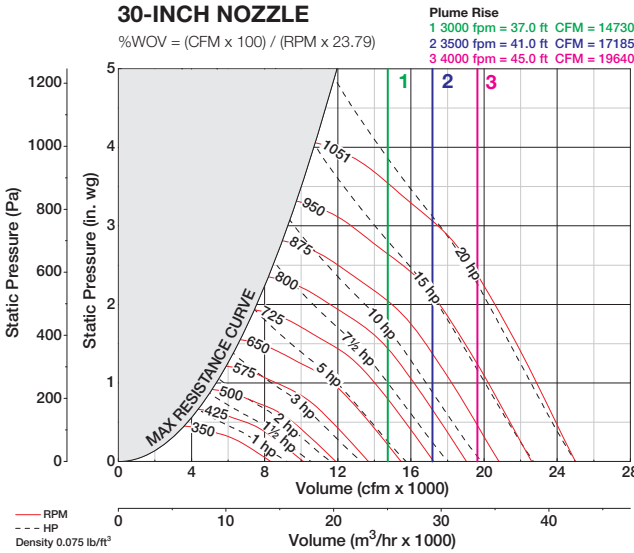

## 32-INCH NOZZLE

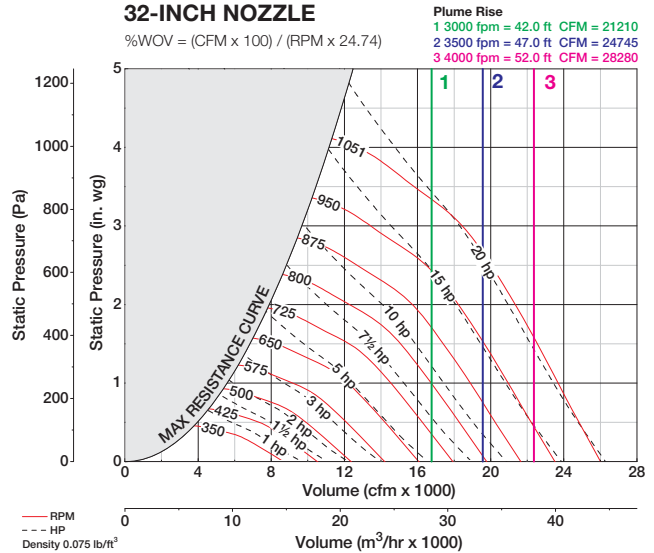

## 34-INCH NOZZLE

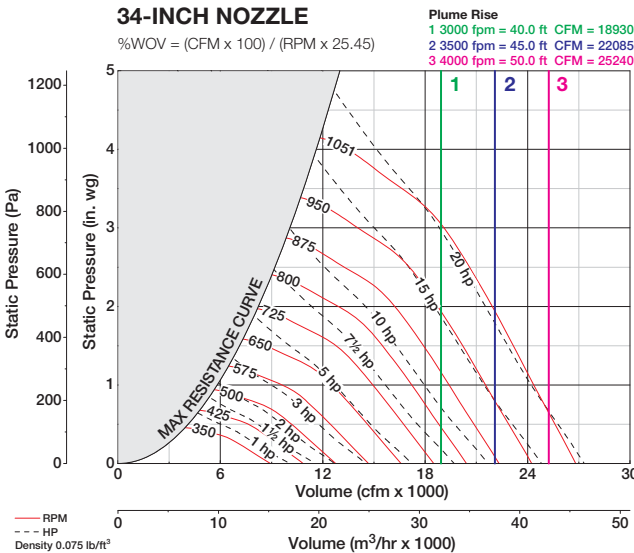

## 36-INCH NOZZLE

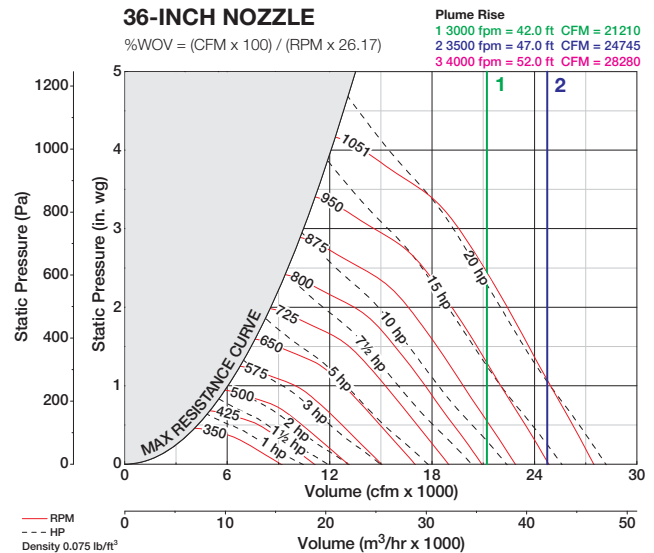

Performance certified for installation Type A: Free inlet, Free outlet. Rating Method "A" (Constant Speed, Transmission Loss Not Included). Power rating (Bhp) does not include transmission losses. Performance ratings do not include the effects of appurtenances (accessories). Plume rise calculated assuming a 10 mph crosswind. 3,000 ft/min. is the minimum recommended outlet velocity per ANSI Z9.5.

# Sound Performance Data

Once a Vektor®-H unit has been selected that meets performance specifications, use the following procedure to attain sound data for the specific fan RPM and % WOV. Interpolation will be used to determine the eight sound power levels and decibel rating.

The Vektor-H Size 18, 13-inch nozzle is operating at 1530 rpm and 75% WOV. Viewing the Size 18 Sound Power Table, interpolation between 60 and 80% WOV is needed to find values for 75% WOV. Also note that interpolation between 1450 and 1750 rpm will be used to find sound power at 1530 rpm. Finally, an interpolation using nozzle outlet area will be performed to provide final sound power using the Nozzle Outlet Area Chart provided on page 3.

## Vektor-H Size 18

Inlet Sound Power by Octave Band																						
Nozzle Size		9 in. Nozzle										19 in. Nozzle										
RPM	%WOV	1	2	3	4	5	6	7	8	L <sub>wA</sub>	dBA	1	2	3	4	5	6	7	8	L <sub>wA</sub>	dBA	
1150	40	81	77	72	73	67	64	57	49	74	62	82	76	73	74	68	64	57	51	74	63	
1450	100	81	75	76	77	78	73	67	60	81	70	82	78	82	83	81	78	71	62	85	74	
<b>Example</b>	1450	80	85	78	77	76	73	71	65	58	79	67	79	76	82	81	80	75	68	61	84	72
	1450	60	88	81	79	78	73	71	65	57	80	68	78	78	78	77	73	67	59	81	69	
	1450	50	88	81	79	77	72	71	64	57	79	67	83	79	78	78	74	72	65	58	80	68
	1450	40	87	81	78	77	72	70	64	57	79	67	87	80	78	77	72	70	64	57	79	67
	1750	100	84	78	82	80	81	78	72	65	85	73	86	82	86	86	85	82	77	67	89	78
<b>Example</b>	1750	80	88	81	82	80	77	76	70	63	83	71	84	79	85	84	83	80	73	66	87	76
	1750	60	90	84	84	82	77	76	70	62	84	72	84	78	82	81	81	78	71	64	85	73
	1750	50	90	84	84	82	77	75	69	62	84	72	87	81	83	81	78	76	70	64	84	72

### EXAMPLE: Calculations for a Vektor-H Size 18

First, interpolate the 19-inch nozzle data at 1450 rpm between 80% and 60% WOV to find 75% WOV:

$$1450 \text{ rpm at } 75\% \text{ WOV, dBA} = \left[ 72 \text{ dB} - \left\{ \left( \frac{80\% - 75\%}{80\% - 60\%} \right) \times (72 \text{ dB} - 69 \text{ dB}) \right\} \right] = 71.58 \text{ dBA}$$

Perform a similar interpolation with data at 1750 rpm to find the dB level for 75% WOV:

$$1750 \text{ rpm at } 75\% \text{ WOV, dBA} = \left[ 76 \text{ dB} - \left\{ \left( \frac{80\% - 75\%}{80\% - 60\%} \right) \times (76 \text{ dB} - 73 \text{ dB}) \right\} \right] = 75.19 \text{ dBA}$$

Interpolate between the 1450 and 1750 rpm values at 75% WOV by replacing the percent WOV in the equation with the RPM values and use the calculated dB from the 75% WOV steps.

$$1530 \text{ rpm at } 75\% \text{ WOV, dBA} = \left[ 75.19 \text{ dB} - \left\{ \left( \frac{1750 - 1530}{1750 - 1450} \right) \times (75.19 \text{ dB} - 71.58 \text{ dB}) \right\} \right] = 72.54 \text{ dBA}$$

Perform the same interpolation procedures for the 9-inch nozzle which provides the dBA for 75% WOV at 1530 rpm (= 68.45 dBA). Using the values calculated for 75% WOV at 1530 rpm, interpolation by nozzle outlet area should be used between small and large nozzles to find the sound power of the 13-inch nozzle.

$$13\text{-inch nozzle} \\ 1530 \text{ rpm at } 75\% \text{ WOV, dBA} = \left[ 72.54 \text{ dB} - \left\{ \left( \frac{1.97 \text{ in}^2 - 0.92 \text{ in}^2}{1.97 \text{ in}^2 - 0.44 \text{ in}^2} \right) \times (72.54 \text{ dB} - 68.45 \text{ dB}) \right\} \right] = 69.73 \text{ dBA}$$

### AMCA Licensed Ratings

Sound tests of Vektor-H Laboratory Exhaust Systems were conducted in Greenheck's AMCA Accredited Laboratory in accordance with AMCA Standard 300. Inlet sound ratings comply with AMCA Publication 311, qualifying these models to bear the AMCA seal for sound and air performance. The sound power levels published here can be compared directly with those of other similarly rated fans, or used as a baseline to determine sound levels in occupied spaces.

### Test Methods

The sound data in this brochure is the result of extensive testing, which included inlet sound tests on Vektor-H Laboratory Exhaust Systems. AMCA Standard 300 clearly defines methods used to test fans in a reverberant sound test room. The reverberant room is specifically designed to allow sound waves to be dispersed evenly throughout the room. The walls have a hard surface that reflects sound and are positioned to prevent resonances which could result in quiet areas within the room.

Inlet Sound Power by Octave Band																					
Nozzle Size		4 in. Nozzle										9 in. Nozzle									
RPM	%WOV	1	2	3	4	5	6	7	8	L <sub>wiA</sub>	dBA	1	2	3	4	5	6	7	8	L <sub>wiA</sub>	dBA
1800	100	81	81	73	69	65	63	58	53	73	61	79	81	74	74	69	65	60	54	75	64
1800	80	82	80	74	69	65	63	58	53	73	61	80	81	73	72	67	64	58	54	74	62
1800	60	81	80	74	69	65	63	58	53	73	61	81	80	73	70	66	63	58	53	73	61
1800	50	79	79	74	70	65	63	58	53	73	61	82	80	73	69	65	63	57	53	72	61
1800	40	77	78	73	70	65	63	58	53	72	61	83	80	73	69	65	63	57	53	72	61
2350	100	82	84	80	75	72	68	63	58	78	67	81	84	81	80	78	71	67	60	82	71
2350	80	84	84	81	76	72	67	63	58	79	67	81	84	81	80	75	69	65	59	81	69
2350	60	85	84	82	77	73	68	63	58	80	68	82	84	80	78	73	68	64	59	79	68
2350	50	86	84	82	77	73	68	63	58	80	68	83	83	79	76	72	68	63	59	78	67
2350	40	87	84	83	77	73	68	63	58	80	68	83	84	79	76	72	68	63	59	78	67
2900	100	85	88	85	81	78	72	68	63	84	72	81	87	87	84	82	76	73	65	87	75
2900	80	85	88	85	82	78	72	68	62	84	72	82	87	87	83	82	74	70	64	86	75
2900	60	90	90	85	83	79	72	68	63	85	73	82	87	87	82	78	73	69	63	84	73
2900	50	93	90	85	83	80	72	68	63	85	74	84	87	86	81	78	72	68	63	84	72
2900	40	96	91	86	83	80	72	69	63	85	74	84	87	87	82	78	72	68	63	84	73
3450	100	89	90	87	86	82	76	73	66	87	76	84	91	89	88	86	80	77	70	90	79
3450	80	91	91	88	87	83	76	72	66	88	77	85	91	90	88	86	79	75	68	90	79
3450	60	95	91	88	88	84	76	73	66	89	78	87	90	90	86	83	77	73	67	88	77
3450	50	98	91	88	88	84	76	73	66	89	78	89	90	89	86	82	77	73	67	88	76
3450	40	100	91	88	88	85	77	73	66	90	78	90	90	90	86	82	77	73	67	88	77
4050	100	94	94	90	90	86	81	77	70	91	80	86	94	92	93	91	86	82	75	95	84
4050	80	98	94	91	92	87	81	77	70	93	81	89	95	92	92	89	83	81	72	94	82
4050	60	101	92	91	93	88	81	77	70	93	82	93	93	93	91	87	82	78	71	93	81
4050	50	103	91	91	94	89	81	78	70	94	83	95	93	93	90	87	81	78	71	92	81
4050	40	104	90	91	95	89	81	78	70	95	83	97	93	93	90	86	81	78	71	92	80

# Vektor-H Size 10

Inlet Sound Power by Octave Band																					
Nozzle Size		5 in. Nozzle										10 in. Nozzle									
RPM	%WOV	1	2	3	4	5	6	7	8	L <sub>wiA</sub>	dBA	1	2	3	4	5	6	7	8	L <sub>wiA</sub>	dBA
1800	100	77	77	70	69	67	64	62	55	72	61	77	77	72	74	71	66	62	55	76	64
1800	80	79	77	71	67	65	64	62	55	72	60	76	78	72	72	68	64	61	54	74	62
1800	60	82	78	73	66	64	63	61	55	72	60	76	78	70	69	67	63	61	55	72	61
1800	50	83	79	73	67	65	63	61	55	72	61	78	76	71	68	66	63	61	55	72	60
1800	40	84	80	74	67	65	63	61	55	73	61	82	77	71	66	64	63	61	55	71	60
2350	100	81	79	74	75	72	67	65	60	77	65	82	79	79	80	78	71	68	61	82	70
2350	80	84	81	76	73	71	66	65	60	76	65	80	79	76	78	75	68	65	60	79	68
2350	60	86	82	79	73	70	66	64	60	77	65	80	78	73	75	73	67	65	60	77	66
2350	50	86	83	81	74	71	66	64	60	78	66	81	80	74	74	72	67	64	60	77	65
2350	40	87	84	83	75	71	67	64	61	79	68	82	81	76	74	71	66	64	60	77	65
2900	100	83	80	78	79	77	73	70	64	82	70	86	81	82	84	83	77	73	66	87	75
2900	80	85	82	79	78	75	71	69	64	80	69	83	80	80	82	80	74	70	64	84	72
2900	60	86	85	83	79	76	71	68	64	82	70	83	79	77	80	77	72	69	65	82	70
2900	50	87	87	86	80	77	71	68	64	83	72	84	82	79	79	76	71	68	64	81	69
2900	40	89	89	88	82	77	72	68	64	85	73	86	84	80	78	75	71	68	64	81	69
3450	100	84	82	81	83	80	77	74	68	85	74	88	84	84	87	87	83	79	71	91	79
3450	80	86	85	83	83	79	76	73	68	85	73	86	84	83	85	84	79	75	68	88	76
3450	60	88	87	87	86	80	75	72	67	87	75	86	83	80	83	80	77	73	68	85	74
3450	50	91	90	88	87	81	76	72	67	88	76	87	84	82	83	79	76	72	68	85	73
3450	40	93	92	90	88	82	76	72	68	89	77	89	86	84	84	79	75	71	67	85	74
4050	100	85	84	85	87	84	82	79	72	89	78	90	89	85	91	90	90	84	76	95	84
4050	80	87	87	87	88	83	80	77	71	89	78	90	89	85	90	88	85	80	73	92	81
4050	60	91	90	90	93	85	80	77	71	92	81	89	87	84	87	84	82	78	72	89	78
4050	50	95	92	91	94	87	80	77	71	93	82	90	88	85	87	83	80	77	71	89	77
4050	40	98	94	92	95	88	81	77	71	94	83	92	89	88	90	83	79	76	70	90	78

Values shown are for inlet L<sub>wiA</sub> sound power levels for Installation Type A: Free inlet, Free outlet. The sound power level ratings shown are in decibels, referred to 10<sup>-12</sup> watts, calculated per AMCA Standard 301. The A-weighted sound ratings shown have been calculated per AMCA International Standard 301. The sound ratings shown are loudness values at a distance of 5 ft. (1.5 m) in a hemispherical free field calculated per AMCA International Standard 301. Values shown are for Installation Type A: free inlet hemispherical sone levels. dBA levels are not licensed by AMCA International. The AMCA Certified Ratings Seal applies to L<sub>wiA</sub> values only.

Inlet Sound Power by Octave Band																					
Nozzle Size		6 in. Nozzle										13 in. Nozzle									
RPM	%WOV	1	2	3	4	5	6	7	8	L <sub>wiA</sub>	dBA	1	2	3	4	5	6	7	8	L <sub>wiA</sub>	dBA
1400	100	85	76	68	65	60	59	54	50	69	57	75	79	72	67	63	66	58	50	72	60
1400	80	86	75	69	65	61	59	54	49	69	57	76	79	72	66	61	61	54	50	70	59
1400	60	87	76	70	66	61	59	54	49	70	58	81	78	71	64	60	59	53	49	69	58
1400	50	85	76	70	65	61	59	54	49	69	58	83	78	71	65	60	59	53	49	69	58
1400	40	84	76	70	65	61	59	54	49	69	57	86	78	70	65	60	59	53	49	69	58
1850	100	90	82	74	70	66	65	61	56	74	63	78	80	76	74	69	71	69	59	78	66
1850	80	91	82	75	72	68	64	59	54	75	64	81	81	76	73	68	67	62	56	76	64
1850	60	90	83	76	73	68	64	59	54	76	64	86	81	74	71	65	64	59	54	74	62
1850	50	89	82	76	73	68	64	59	54	75	64	88	82	74	71	66	64	59	54	74	63
1850	40	87	81	76	72	68	64	59	54	75	63	91	83	75	72	67	64	58	54	75	64
2300	100	91	87	80	77	72	68	64	59	79	68	83	82	81	80	76	71	78	66	83	72
2300	80	92	87	79	78	74	69	64	59	80	69	85	83	80	78	74	70	70	61	80	69
2300	60	92	86	81	79	74	69	64	59	81	69	89	84	79	77	72	68	64	59	79	67
2300	50	90	85	81	79	74	69	64	59	80	69	90	86	79	77	72	68	64	59	79	68
2300	40	89	84	81	78	74	69	64	59	80	69	91	87	79	78	72	68	63	59	80	68
2750	100	93	90	85	81	77	72	68	63	84	72	86	85	84	85	80	75	79	72	87	75
2750	80	94	90	84	83	78	73	69	63	84	73	88	86	83	84	78	74	73	67	85	73
2750	60	93	90	86	84	79	74	69	63	85	74	92	88	83	82	76	72	68	63	83	72
2750	50	93	89	85	84	79	74	69	63	85	74	93	89	84	82	77	72	68	63	84	72
2750	40	93	88	85	83	78	74	69	63	85	73	94	90	84	82	77	73	68	63	84	72
3274	100	95	93	91	87	82	77	73	68	89	77	90	89	86	91	85	81	80	80	91	80
3274	80	96	93	91	88	83	79	74	68	90	78	93	89	87	91	84	79	77	74	91	79
3274	60	96	94	91	90	85	79	74	68	91	79	95	93	89	89	82	77	74	68	89	78
3274	50	96	94	90	89	84	79	74	68	90	79	96	93	89	88	82	77	74	68	89	77
3274	40	97	94	89	89	84	79	74	69	90	79	97	93	89	88	82	78	74	68	89	78

# Vektor-H Size 13

Inlet Sound Power by Octave Band																					
Nozzle Size		7 in. Nozzle										14 in. Nozzle									
RPM	%WOV	1	2	3	4	5	6	7	8	L <sub>wiA</sub>	dBA	1	2	3	4	5	6	7	8	L <sub>wiA</sub>	dBA
950	100	76	74	67	61	57	54	50	46	65	54	76	72	66	71	63	56	51	47	70	59
950	80	77	73	66	60	57	54	50	47	65	53	74	71	67	70	60	55	51	47	69	57
950	60	78	73	66	61	57	54	50	47	65	53	74	71	67	65	57	54	50	47	66	54
950	50	79	73	67	61	57	54	50	47	65	54	74	71	66	63	56	53	50	48	65	53
950	40	80	73	67	60	57	54	51	48	65	54	75	71	66	60	55	53	50	48	64	52
1450	100	87	77	71	70	65	63	58	54	72	61	87	78	74	74	71	69	62	55	77	65
1450	80	87	77	72	70	64	62	57	53	72	61	82	79	73	74	71	66	60	54	76	64
1450	60	88	78	72	71	65	62	57	53	73	61	85	78	75	73	66	63	58	53	74	63
1450	50	88	79	73	71	65	62	57	53	73	61	85	77	74	72	64	62	57	52	73	61
1450	40	88	79	74	70	65	62	57	53	73	61	85	76	73	70	63	61	56	52	72	60
1950	100	89	80	77	76	71	69	65	60	78	66	83	80	80	78	75	76	72	63	82	70
1950	80	90	81	78	77	72	68	64	59	78	67	80	80	76	77	74	74	68	61	80	69
1950	60	91	83	79	78	73	68	64	59	79	68	84	80	78	77	72	70	65	60	79	67
1950	50	92	84	80	78	73	68	64	59	80	68	86	80	77	76	71	68	64	59	78	66
1950	40	92	84	80	77	73	68	64	59	79	68	87	80	77	76	70	67	63	59	77	66
2450	100	93	86	80	81	77	74	70	65	83	71	86	83	82	84	80	79	78	71	87	75
2450	80	93	86	81	82	77	73	69	64	83	72	85	84	80	82	78	78	74	68	85	73
2450	60	94	88	83	84	79	74	69	64	85	73	88	83	80	82	77	74	70	65	83	72
2450	50	94	88	84	84	78	74	69	64	85	73	90	84	80	81	76	73	69	64	82	71
2450	40	94	88	84	83	78	74	69	64	84	73	91	84	81	80	75	72	68	64	82	70
2971	100	97	91	83	86	82	79	75	70	88	76	89	86	84	89	85	82	85	79	92	80
2971	80	97	91	84	87	83	78	74	69	88	77	91	87	83	86	83	81	80	74	89	77
2971	60	97	93	87	89	85	80	75	69	90	79	93	87	82	87	82	79	76	70	88	76
2971	50	96	93	88	89	84	80	75	69	90	78	94	88	84	86	82	78	75	70	87	76
2971	40	96	93	89	89	84	79	75	69	90	78	95	89	85	85	81	77	74	69	87	75

Values shown are for inlet L<sub>wiA</sub> sound power levels for Installation Type A: Free inlet, Free outlet. The sound power level ratings shown are in decibels, referred to 10<sup>-12</sup> watts, calculated per AMCA Standard 301. The A-weighted sound ratings shown have been calculated per AMCA International Standard 301. The sound ratings shown are loudness values at a distance of 5 ft. (1.5 m) in a hemispherical free field calculated per AMCA International Standard 301. Values shown are for Installation Type A: free inlet hemispherical sone levels. dBA levels are not licensed by AMCA International. The AMCA Certified Ratings Seal applies to L<sub>wiA</sub> values only.



Inlet Sound Power by Octave Band																					
Nozzle Size		8 in. Nozzle										18 in. Nozzle									
RPM	%WOV	1	2	3	4	5	6	7	8	L <sub>wiA</sub>	dBA	1	2	3	4	5	6	7	8	L <sub>wiA</sub>	dBA
750	100	73	69	65	59	57	52	44	38	63	51	72	69	66	69	62	56	47	40	68	57
750	80	74	69	64	59	58	52	44	38	63	51	73	69	65	65	59	53	46	39	65	54
750	60	76	69	65	59	58	52	44	38	63	52	72	68	65	61	56	52	44	38	63	52
750	50	77	69	65	58	58	52	44	38	63	52	73	68	65	60	56	51	44	38	63	51
750	40	77	69	64	58	58	52	44	38	63	51	73	68	65	58	56	51	43	38	62	51
1350	100	84	78	74	71	71	66	59	52	75	64	83	79	76	76	75	76	67	57	81	69
1350	80	86	79	75	72	71	66	58	51	75	64	83	77	75	74	73	70	62	54	77	66
1350	60	88	80	76	74	71	66	58	51	76	65	82	77	75	73	71	67	60	52	76	64
1350	50	87	80	76	73	71	66	58	51	76	64	83	79	75	72	71	66	59	52	75	64
1350	40	86	80	76	72	71	65	58	51	76	64	84	80	74	71	70	65	58	51	75	63
1750	100	88	82	79	77	74	71	66	60	80	68	87	80	80	80	79	85	78	65	88	76
1750	80	91	83	80	79	75	71	65	59	81	69	86	79	79	79	76	77	70	62	82	71
1750	60	93	85	82	81	76	71	65	59	82	71	87	80	78	78	74	73	66	60	80	69
1750	50	92	84	82	80	75	71	65	59	81	70	88	81	78	78	73	71	65	59	79	68
1750	40	91	84	82	79	75	71	65	59	81	70	90	83	78	77	73	70	64	58	79	68
2150	100	91	86	82	82	78	76	71	65	84	73	86	82	84	86	83	85	83	72	90	79
2150	80	94	87	84	84	80	76	71	64	86	74	86	83	85	86	80	80	79	68	88	76
2150	60	96	90	86	86	81	77	71	65	87	76	87	82	81	83	79	77	72	65	85	73
2150	50	94	88	86	85	81	77	71	65	87	75	90	84	82	82	78	76	71	65	84	72
2150	40	93	87	86	84	80	76	71	64	86	74	93	86	82	82	77	75	70	64	84	72
2431	100	94	88	85	85	81	79	75	69	87	76	86	84	87	90	86	86	87	76	93	82
2431	80	95	90	86	87	83	80	75	68	89	77	86	85	89	90	83	83	85	72	92	80
2431	60	97	93	89	89	85	81	75	69	91	79	87	84	84	86	82	80	75	69	88	76
2431	50	96	91	89	88	84	80	75	69	90	78	91	86	84	86	81	79	74	68	87	76
2431	40	95	90	89	88	84	80	75	68	90	78	95	88	85	85	81	78	73	68	87	75

# Vektor-H Size 18

Inlet Sound Power by Octave Band																					
Nozzle Size		9 in. Nozzle										19 in. Nozzle									
RPM	%WOV	1	2	3	4	5	6	7	8	L <sub>wiA</sub>	dBA	1	2	3	4	5	6	7	8	L <sub>wiA</sub>	dBA
700	100	82	71	64	67	58	53	45	37	67	55	76	72	69	68	60	55	47	39	68	57
700	80	81	71	64	63	57	52	44	36	65	53	78	72	68	67	58	54	46	38	67	56
700	60	77	70	63	60	57	52	44	35	63	52	77	71	67	68	57	53	46	37	67	56
700	50	77	71	63	60	56	52	44	35	63	52	77	71	66	68	56	53	45	37	67	56
700	40	77	71	63	59	56	52	44	35	63	51	77	71	65	67	56	52	45	37	66	55
1150	100	75	76	72	75	71	66	60	52	76	64	77	77	77	80	74	71	62	55	80	69
1150	80	78	76	72	73	69	65	58	51	74	63	76	79	76	78	71	67	60	53	78	66
1150	60	82	77	73	74	68	64	57	50	74	63	75	76	73	75	70	66	59	52	76	64
1150	50	82	77	72	73	67	64	57	50	74	62	78	76	73	74	69	65	58	51	75	63
1150	40	81	77	72	73	67	64	57	49	74	62	82	76	73	74	68	64	57	51	74	63
1450	100	81	75	76	77	78	73	67	60	81	70	82	78	82	83	81	78	71	62	85	74
1450	80	85	78	77	76	73	71	65	58	79	67	79	76	82	81	80	75	68	61	84	72
1450	60	88	81	79	78	73	71	65	57	80	68	78	76	78	78	77	73	67	59	81	69
1450	50	88	81	79	77	72	71	64	57	79	67	83	79	78	78	74	72	65	58	80	68
1450	40	87	81	78	77	72	70	64	57	79	67	87	80	78	77	72	70	64	57	79	67
1750	100	84	78	82	80	81	78	72	65	85	73	86	82	86	86	85	82	77	67	89	78
1750	80	88	81	82	80	77	76	70	63	83	71	84	79	85	84	83	80	73	66	87	76
1750	60	90	84	84	82	77	76	70	62	84	72	84	78	82	81	81	78	71	64	85	73
1750	50	90	84	84	82	77	75	69	62	84	72	87	81	83	81	78	76	70	64	84	72
1750	40	89	84	84	81	77	74	69	62	83	72	90	84	83	82	76	75	69	63	83	72
2099	100	88	82	88	83	84	84	78	71	89	78	91	86	91	90	88	88	83	74	94	82
2099	80	93	85	87	85	82	82	76	69	88	77	89	82	90	88	87	87	80	72	92	81
2099	60	93	88	89	87	83	81	75	69	89	78	91	80	87	83	84	84	77	70	89	78
2099	50	92	89	90	87	82	80	75	69	89	77	92	85	88	85	83	82	76	70	89	77
2099	40	92	89	90	87	82	79	74	69	89	77	93	88	88	86	81	80	75	69	88	76

Values shown are for inlet L<sub>wiA</sub> sound power levels for Installation Type A: Free inlet, Free outlet. The sound power level ratings shown are in decibels, referred to 10<sup>-12</sup> watts, calculated per AMCA Standard 301. The A-weighted sound ratings shown have been calculated per AMCA International Standard 301. The sound ratings shown are loudness values at a distance of 5 ft. (1.5 m) in a hemispherical free field calculated per AMCA International Standard 301. Values shown are for Installation Type A: free inlet hemispherical sone levels. dBA levels are not licensed by AMCA International. The AMCA Certified Ratings Seal applies to L<sub>wiA</sub> values only.

Inlet Sound Power by Octave Band																					
Nozzle Size		10 in. Nozzle										22 in. Nozzle									
RPM	%WOV	1	2	3	4	5	6	7	8	L <sub>wiA</sub>	dBA	1	2	3	4	5	6	7	8	L <sub>wiA</sub>	dBA
500	100	72	69	62	60	57	50	43	35	62	51	75	69	68	64	60	53	44	37	66	54
500	80	72	70	61	60	57	50	42	35	62	51	73	69	66	63	59	52	43	36	65	53
500	60	72	70	61	60	57	50	42	34	62	51	71	67	63	62	58	51	43	36	63	52
500	50	73	71	60	59	57	50	42	34	62	51	71	67	62	61	58	51	42	35	63	51
500	40	73	71	60	59	57	50	42	34	62	51	73	67	61	59	56	49	42	34	61	50
800	100	79	73	69	69	67	63	54	48	71	60	79	81	79	77	73	68	58	51	78	67
800	80	80	74	69	68	65	61	53	46	70	59	76	77	75	74	71	66	57	50	76	64
800	60	81	74	69	68	64	61	53	46	70	58	74	74	70	71	69	64	56	49	73	62
800	50	81	74	68	68	64	60	53	46	70	58	80	74	69	69	66	61	54	47	71	59
800	40	81	74	68	68	64	60	52	46	70	58	82	74	69	68	64	60	53	47	70	58
1100	100	87	82	79	75	74	71	63	57	79	67	82	87	88	83	81	78	69	61	86	75
1100	80	86	81	77	74	71	69	62	55	77	66	79	84	85	80	80	75	66	59	84	73
1100	60	87	82	77	74	71	68	61	55	77	65	77	81	81	76	77	73	65	58	81	69
1100	50	86	82	77	74	71	68	61	55	77	65	85	81	79	74	74	70	63	57	78	67
1100	40	87	82	77	74	70	68	61	55	77	65	87	81	78	74	72	69	62	56	78	66
1400	100	92	88	86	81	79	77	70	64	85	73	86	88	92	86	84	81	75	67	90	78
1400	80	91	87	84	80	77	75	69	62	83	72	84	85	89	83	82	79	72	65	87	76
1400	60	91	87	83	79	76	74	68	62	82	71	84	83	87	79	81	78	71	64	85	74
1400	50	90	87	84	80	76	74	68	62	83	71	89	83	85	78	78	76	69	64	83	72
1400	40	90	88	84	80	76	74	68	62	83	71	91	84	84	78	77	75	69	63	83	71
1722	100	97	93	91	86	84	82	77	70	90	78	90	86	94	89	85	83	80	72	92	80
1722	80	96	93	91	86	83	81	75	69	89	78	90	83	92	85	82	81	76	70	89	77
1722	60	95	92	90	85	82	80	75	69	88	77	92	82	91	83	83	82	76	70	89	77
1722	50	94	92	90	85	82	80	75	69	88	77	93	85	89	82	82	81	75	70	88	76
1722	40	94	93	91	86	82	80	75	68	89	78	94	87	89	83	82	81	75	69	88	76

# Vektor-H Size 24

Inlet Sound Power by Octave Band																					
Nozzle Size		13 in. Nozzle										27 in. Nozzle									
RPM	%WOV	1	2	3	4	5	6	7	8	L <sub>wiA</sub>	dBA	1	2	3	4	5	6	7	8	L <sub>wiA</sub>	dBA
425	100	69	70	65	63	56	51	47	38	64	52	72	71	74	63	59	53	47	39	68	57
425	80	70	71	62	62	56	51	46	37	63	52	70	70	73	63	58	53	46	38	67	56
425	60	70	69	61	62	55	51	45	37	63	51	66	69	68	63	56	51	45	37	65	53
425	50	70	69	61	62	55	51	45	37	63	51	67	69	66	62	55	51	45	37	63	52
425	40	70	69	61	62	55	50	45	36	62	51	69	69	63	61	55	50	44	36	62	51
675	100	72	75	74	69	68	63	57	50	73	61	76	79	81	73	72	67	59	52	77	66
675	80	78	75	75	68	68	62	55	48	73	61	73	77	79	72	70	64	58	51	76	64
675	60	78	76	75	67	67	62	55	47	72	61	72	75	75	69	68	62	56	50	73	61
675	50	79	76	75	67	67	62	55	47	72	61	75	75	74	68	67	61	56	48	72	60
675	40	79	75	75	67	67	61	55	47	72	60	78	75	74	66	66	60	55	47	71	60
925	100	77	77	78	72	72	69	65	59	77	66	78	85	85	78	75	75	68	60	82	71
925	80	84	81	81	75	74	70	64	57	79	68	76	84	82	74	74	71	66	58	80	68
925	60	85	82	81	74	73	69	64	56	79	67	75	82	79	71	73	69	64	58	78	66
925	50	85	82	81	74	73	69	64	56	79	67	81	80	79	72	72	68	64	57	77	66
925	40	85	82	81	74	73	69	64	56	79	67	83	81	80	72	72	68	64	57	77	66
1175	100	81	81	84	77	77	75	71	65	82	71	82	86	92	83	81	80	76	66	88	77
1175	80	89	86	86	80	79	76	71	64	84	73	80	84	89	80	79	77	73	64	85	74
1175	60	89	87	86	80	79	75	71	63	84	73	78	82	85	76	77	75	71	64	83	71
1175	50	89	87	86	80	79	75	70	63	84	73	85	84	85	78	78	74	70	64	83	72
1175	40	89	87	86	80	79	75	70	63	84	73	88	86	86	79	78	74	70	63	84	72
1425	100	86	85	90	82	81	80	77	70	88	76	86	87	98	89	86	85	83	72	94	82
1425	80	94	91	91	85	84	81	77	70	89	78	84	84	96	86	84	82	79	71	91	80
1425	60	92	91	92	86	84	81	77	70	90	78	82	82	91	81	81	79	77	70	88	76
1425	50	93	92	92	86	84	81	77	70	90	78	90	89	92	84	83	80	76	70	89	77
1425	40	93	92	92	86	84	81	76	70	90	78	93	91	92	85	84	80	76	70	89	78

Values shown are for inlet L<sub>wiA</sub> sound power levels for Installation Type A: Free inlet, Free outlet. The sound power level ratings shown are in decibels, referred to 10<sup>-12</sup> watts, calculated per AMCA Standard 301. The A-weighted sound ratings shown have been calculated per AMCA International Standard 301. The sound ratings shown are loudness values at a distance of 5 ft. (1.5 m) in a hemispherical free field calculated per AMCA International Standard 301. Values shown are for Installation Type A: free inlet hemispherical sone levels. dBA levels are not licensed by AMCA International. The AMCA Certified Ratings Seal applies to L<sub>wiA</sub> values only.

Inlet Sound Power by Octave Band																					
Nozzle Size		15 in. Nozzle										30 in. Nozzle									
RPM	%WOV	1	2	3	4	5	6	7	8	L <sub>wiA</sub>	dBA	1	2	3	4	5	6	7	8	L <sub>wiA</sub>	dBA
400	100	67	71	66	63	62	57	47	40	66	55	74	74	71	64	63	57	47	40	68	57
400	80	68	71	67	63	62	57	47	40	67	55	72	74	69	63	61	57	47	39	67	56
400	60	69	72	65	62	62	57	48	40	66	55	69	73	67	62	61	57	47	39	66	55
400	50	69	72	65	62	61	57	47	40	66	54	69	73	67	62	60	56	47	39	66	54
400	40	69	72	65	62	61	57	47	40	66	54	69	72	67	62	60	56	46	39	66	54
700	100	76	80	75	70	70	65	58	52	75	63	80	85	82	75	70	60	52	80	68	68
700	80	81	80	78	72	71	66	58	51	76	65	77	82	79	72	72	66	58	51	77	65
700	60	83	78	78	71	71	65	58	50	76	64	76	80	76	69	70	65	58	50	75	63
700	50	83	78	78	71	70	65	58	50	75	64	80	80	77	70	70	65	58	51	75	63
700	40	84	78	78	71	70	65	57	50	75	64	83	80	78	71	71	65	58	51	76	64
900	100	79	81	79	74	74	72	66	61	79	68	82	87	86	81	82	77	70	60	86	74
900	80	87	83	83	77	76	72	65	60	81	70	79	86	84	78	78	74	66	58	83	71
900	60	87	85	84	78	77	73	66	58	82	71	76	81	80	74	74	71	65	58	79	67
900	50	88	85	84	78	76	72	65	58	82	70	83	82	82	75	75	71	65	58	80	68
900	40	89	86	86	78	76	72	65	58	82	71	86	83	83	76	76	71	65	58	81	69
1100	100	84	85	86	79	79	76	71	65	84	73	85	89	93	86	88	84	76	66	92	80
1100	80	91	88	88	82	81	77	71	64	86	75	82	87	90	83	82	79	72	64	87	76
1100	60	91	89	89	82	81	78	71	64	87	75	79	84	86	78	78	76	70	63	84	72
1100	50	92	89	89	82	81	77	71	64	86	75	88	86	88	80	80	76	70	63	85	74
1100	40	93	90	90	82	81	77	70	63	87	75	91	87	88	81	80	76	70	63	85	74
1279	100	88	89	91	83	82	80	75	68	88	77	89	90	99	92	93	90	81	72	97	86
1279	80	95	91	93	86	85	81	75	68	90	79	85	88	96	87	86	84	77	68	92	81
1279	60	95	92	93	86	85	82	76	69	91	79	82	87	91	82	82	80	75	68	88	76
1279	50	95	93	93	87	85	82	76	69	91	79	93	90	92	85	84	80	75	68	89	78
1279	40	96	93	94	86	85	81	75	68	91	79	95	91	93	86	85	81	75	68	90	79

# Vektor-H Size 36

Inlet Sound Power by Octave Band																					
Nozzle Size		17 in. Nozzle										38 in. Nozzle									
RPM	%WOV	1	2	3	4	5	6	7	8	L <sub>wiA</sub>	dBA	1	2	3	4	5	6	7	8	L <sub>wiA</sub>	dBA
350	100	70	67	66	66	60	53	44	39	66	55	75	71	71	68	62	53	44	38	69	57
350	80	71	69	67	66	60	53	44	39	66	55	73	70	68	67	60	53	42	37	67	56
350	60	71	71	66	65	60	53	43	39	66	54	72	68	67	66	59	52	43	38	66	55
350	50	72	71	66	65	59	53	43	39	66	54	71	68	67	66	58	52	43	38	66	54
350	40	71	71	66	64	59	53	43	39	65	54	71	68	66	66	58	52	43	38	66	54
500	100	79	74	74	71	68	61	54	48	73	61	87	80	78	74	71	64	54	47	76	65
500	80	80	75	75	71	69	61	53	47	74	62	85	78	76	72	68	61	53	46	74	63
500	60	79	74	75	70	68	61	53	46	73	61	81	74	72	69	67	60	53	46	72	60
500	50	79	74	75	70	68	61	53	46	73	61	80	74	73	70	67	60	53	46	72	60
500	40	79	74	74	69	68	60	53	46	72	61	80	74	73	70	66	60	53	46	72	60
650	100	86	81	80	75	74	68	61	55	79	67	89	88	84	78	79	72	63	55	83	71
650	80	86	82	81	76	75	69	61	54	80	68	87	86	83	76	76	69	61	54	81	69
650	60	86	81	81	75	74	68	61	54	79	67	84	81	78	73	73	67	60	54	77	66
650	50	86	81	81	75	74	68	61	54	79	67	86	81	79	74	72	67	60	54	77	66
650	40	86	81	81	75	74	68	61	54	79	67	86	81	80	74	73	67	60	54	78	66
875	100	92	88	87	82	79	76	70	63	85	74	87	95	92	86	88	82	73	66	91	80
875	80	92	90	88	83	81	77	70	64	86	75	84	93	90	83	84	79	71	64	88	77
875	60	92	89	88	83	80	77	70	63	86	75	82	88	86	79	79	76	69	63	84	73
875	50	93	90	88	83	80	76	70	63	86	75	88	88	86	80	79	75	69	63	84	73
875	40	93	90	88	83	80	76	70	63	86	75	91	88	87	81	79	75	69	63	85	73
1051	100	95	93	92	86	84	81	76	69	90	78	91	99	96	91	94	88	81	74	97	85
1051	80	96	94	93	87	86	83	76	70	91	80	86	97	93	87	89	85	77	69	93	81
1051	60	95	94	93	87	86	82	76	70	91	80	86	92	89	82	83	81	75	69	88	77
1051	50	96	94	93	87	85	82	76	69	91	79	90	92	90	84	83	81	75	69	89	77
1051	40	97	94	93	87	85	82	75	69	91	79	94	92	92	85	84	80	75	69	89	78

Values shown are for inlet L<sub>wiA</sub> sound power levels for Installation Type A: Free inlet, Free outlet. The sound power level ratings shown are in decibels, referred to 10<sup>-12</sup> watts, calculated per AMCA Standard 301. The A-weighted sound ratings shown have been calculated per AMCA International Standard 301. The sound ratings shown are loudness values at a distance of 5 ft. (1.5 m) in a hemispherical free field calculated per AMCA International Standard 301. Values shown are for Installation Type A: free inlet hemispherical sone levels. dBA levels are not licensed by AMCA International. The AMCA Certified Ratings Seal applies to L<sub>wiA</sub> values only.

# VEKTOR® Family of Lab Exhaust Systems

**High Plume** - Effective means of creating a discharge plume height to prevent re-entrainment of chemical exhaust fumes into make-up air systems.



### Vektor-H

- High Plume Discharge Nozzle
- Centrifugal wheel
- Compact design / sealed airstream components
- Up to 26,000 cfm and 4 in. wg



### Vektor-MH

- High Plume Nozzle
- Mixed flow wheel / bifurcated housing
- Compact design
- Up to 47,000 cfm and 11 in. wg



### Vektor-CH

- High Plume Nozzle
- Centrifugal wheel
- Up to 56,000 cfm and 12 in. wg

**High Plume Dilution** - Fan design that entrains and mixes outside ambient air into the exhaust airstream prior to exiting out the windband discharge. Potentially hazardous exhaust or exhaust fumes is diluted and dispersed quickly.



### Vektor-MD

- High Plume Discharge Nozzle with Entrainment and Dilution
- Mixed flow wheel / bifurcated housing
- Compact design
- Up to 83,000 cfm and 11.5 in. wg



### Vektor-CD

- High Plume Discharge Nozzle with Entrainment and Dilution
- Centrifugal wheel
- Highest efficiency / easy service design
- Up to 122,000 cfm and 13.5 in. wg

**High Plume Variable Geometry Nozzle (VGN)** - The discharge area automatically adjusts to maintain a constant discharge velocity and remain compliant to design codes. VGN maximizes effective plume heights during periods of reduced flow and lower discharge velocity fixed nozzles.



### Vektor-HS

- VGN discharge nozzle technology
- Variable volume flow – constant velocity discharge
- Centrifugal wheel
- Up to 26,000 cfm and 3.5 in. wg



### Vektor-MS

- VGN discharge nozzle technology
- Variable volume flow – constant velocity discharge
- Mixed flow wheel / bifurcated housing
- Up to 32,000 cfm and 10 in. wg



### Vektor-CS

- VGN discharge nozzle technology
- Variable volume flow – constant velocity discharge
- Centrifugal wheel
- Up to 32,000 cfm and 10 in. wg

## Our Commitment

*As a result of our commitment to continuous improvement, Greenheck reserves the right to change specifications without notice.*

Specific Greenheck product warranties are located on [greenheck.com](http://greenheck.com) within the product area tabs and in the Library under Warranties.



Prepared to Support  
Green Building Efforts

