

These instructions apply to the external field installation of Siemens actuators on Greenheck control dampers. These models are direct drive actuators that rotate to their energized position when power is applied and spring return to their fail position when power is disconnected.

Model	Volts	Running	Holding
GRD221.1U	120	8W	2W
GRD226.1U	120	8W	2W
GRD121.1U	24	8W	2W
GRD126.1U	24	8W	2W

### Galvanized Steel Kit

Item	Part #	Description	Qty
1	723089	Anti-rotation bracket	1
2	815027	Extension pin support bracket	1
3	415455	¼ - 20 splinlock ZP nut	8
4	417279	#10-24x 1.068 ZP stud	1
5	415934	#10-24 HH Nylock ZP nut	1
6	-	Siemens actuator	1
7	415264	¼ - 20 x ½ ZP bolt	8

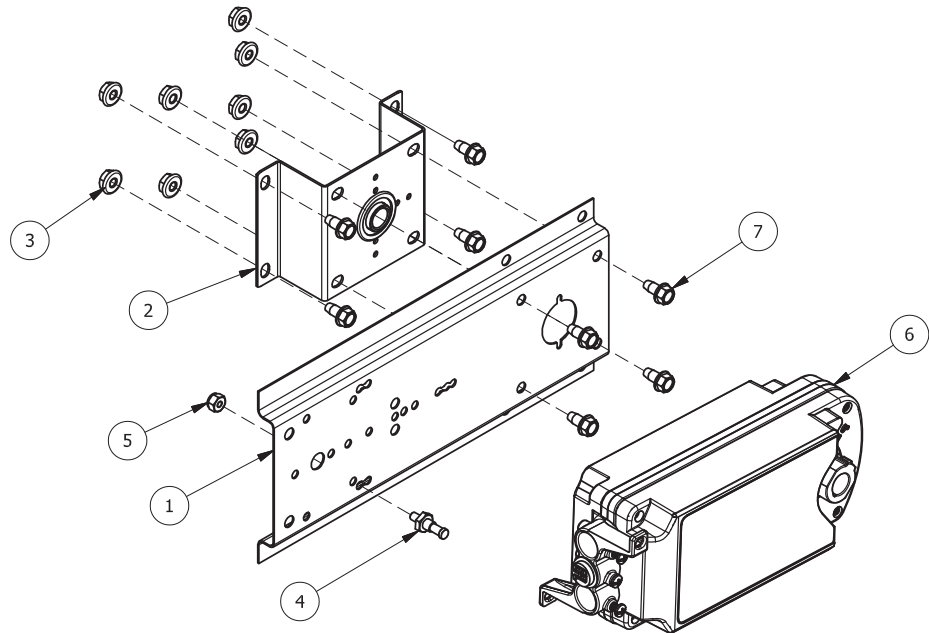

## Instructions for Galvanized Steel Kit

1. Determine actuator fail position and change actuator clamp location if necessary.
2. Install anti-rotation screws/nut opposite the actuator clamp.

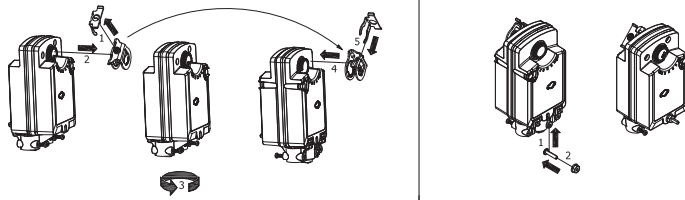

3. Remove the bearing from the stand-off bracket (jackshaft only).
4. Install stand-off bracket. Mark and drill  $\frac{9}{32}$  in. holes (extension pin only).

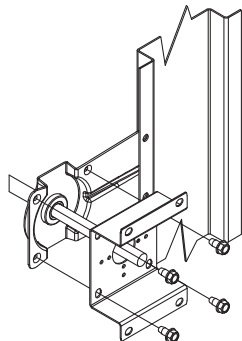

Damper with jackshaft

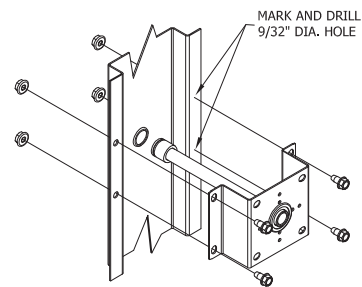

Damper with extension pin

5. Install anti-rotation bracket and actuator. Anti-rotation bracket may be attached (a) perpendicular up, (b) perpendicular down or (c) parallel from duct (shown).

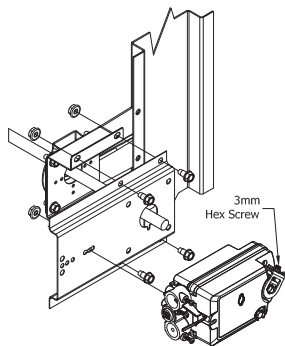

Damper with jackshaft

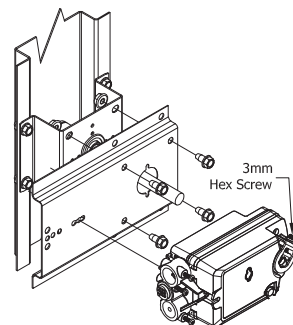

Damper with extension pin

6. Rotate damper blades to desired fail position (open) or (closed, ensure blade seals are compressed). Tighten 3mm hex screw to allow 95 degrees of actuator rotation.
7. Wiring should be per an approved project or job wiring diagram and must comply with all applicable wiring codes.
8. Apply power to the actuator. Damper blades should fully open or close and return to the fail position when power is disconnected.

### 316 Stainless Steel Kit

Item	Part #	Description	Qty
1	687784	316SS standoff bracket	1
2	687405	316SS standoff bracket	1
3	689986	Anti-rotation bracket	1
4	417305	¼-20 316SS spinlock nut	8
5	415868	¼-20x½ 316SS bolt	8
6	415702	#10-32 316SS nut	1
7	416204	¼ 316SS lock washer	1
8	463888	316SS mounting stud	1
9	-	actuator	1

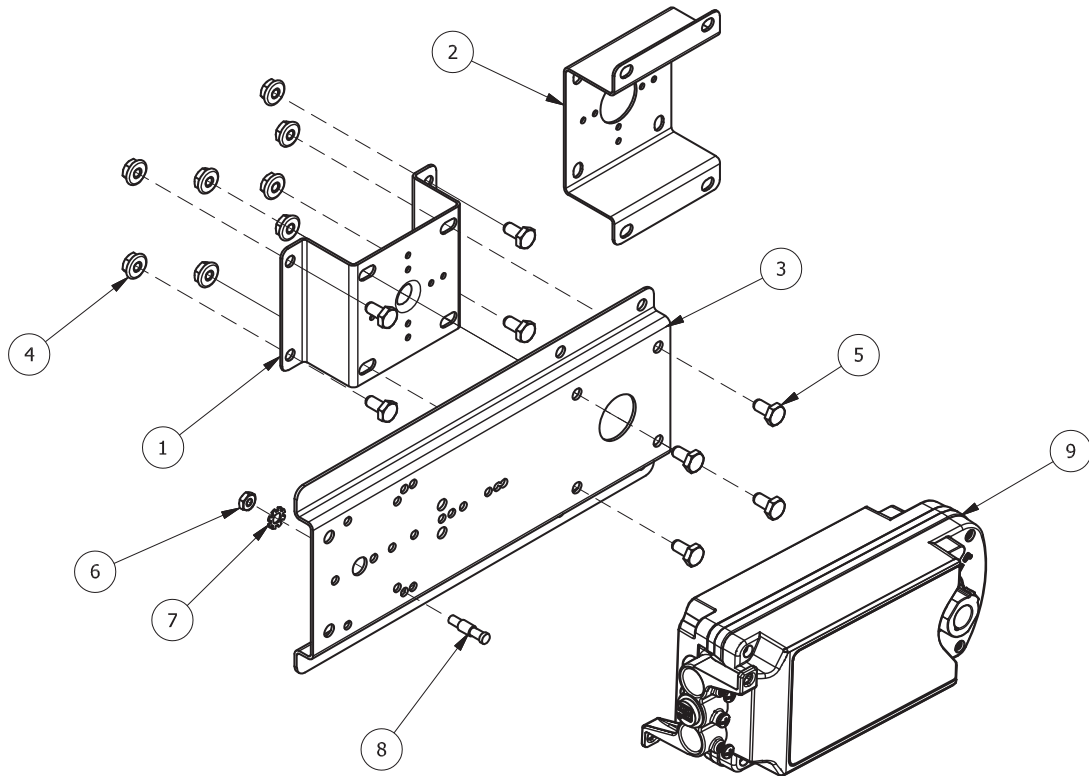

### Instructions for 316SS Kit

1. Determine actuator fail position and change actuator clamp location if necessary.
2. Install anti-rotation screws/nut opposite the actuator clamp.

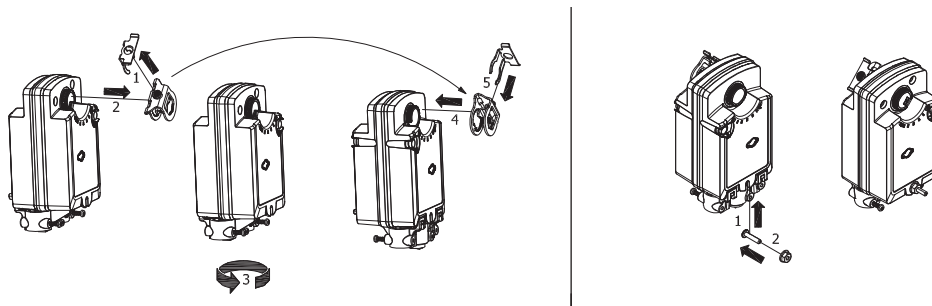

3. Remove the bearing from the stand-off bracket (jackshaft only).
4. Install stand-off bracket. Mark and drill  $\frac{9}{32}$  in. holes (extension pin only).

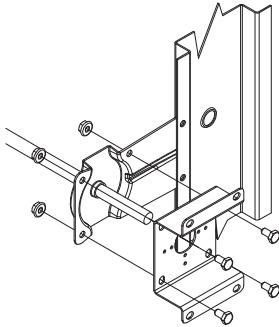

Damper with jackshaft

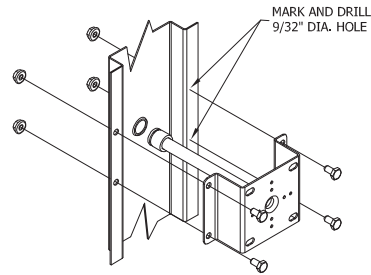

Damper with extension pin

5. Install anti-rotation bracket and actuator. Anti-rotation bracket may be attached (a) perpendicular up, (b) perpendicular down or (c) parallel from duct (shown).

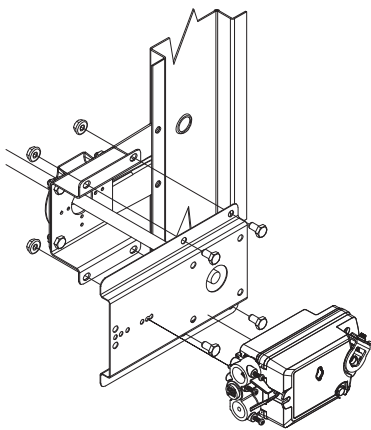

Damper with jackshaft

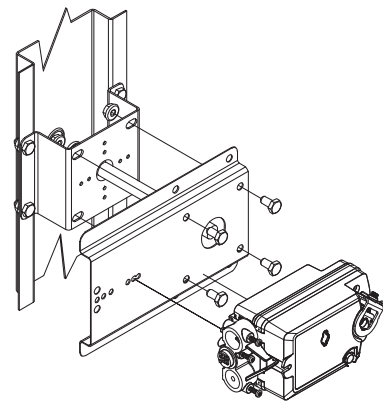

Damper with extension pin

6. Rotate damper blades to desired fail position (open) or (closed, ensure blade seals are compressed). Tighten 3mm hex screw to allow 95 degrees of actuator rotation.
7. Wiring should be per an approved project or job wiring diagram and must comply with all applicable wiring codes.
8. Apply power to the actuator. Damper blades should fully open or close and return to the fail position when power is disconnected.

## Our Commitment

*As a result of our commitment to continuous improvement, Greenheck reserves the right to change specifications without notice.*

Product warranties can be found online at [Greenheck.com](http://Greenheck.com), either on the specific product page or in the literature section of the website at [Greenheck.com/Resources/Library/Literature](http://Greenheck.com/Resources/Library/Literature).

