

Installation, Operation and Maintenance Manual

Please read and save these instructions for future reference. Read carefully before attempting to assemble, install, operate or maintain the product described. Protect yourself and others by observing all safety information. Failure to comply with these instructions will result in voiding of the product warranty and may result in personal injury and/or property damage.

Centrifugal Supply Fans

Fans are specifically designed for filtered roof supply applications. Fans feature permanent washable aluminum filters for years of reliable use and double-width forward-curved wheels for high efficiency and low sound. Available with straight-sided hood.

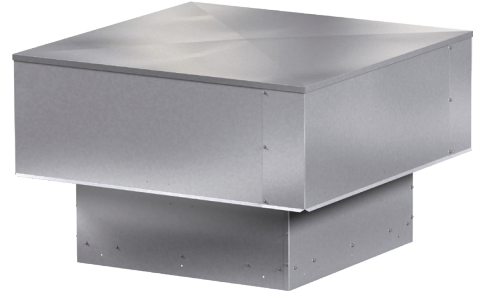

General Safety Information

Only qualified personnel should install this fan. Personnel should have a clear understanding of these instructions and should be aware of general safety precautions. Improper installation can result in electric shock, possible injury due to coming in contact with moving parts, as well as other potential hazards. Other considerations may be required if high winds or seismic activity are present. If more information is needed, contact a licensed professional engineer before moving forward.

1. Follow all local electrical and safety codes, as well as the National Electrical Code (NEC) and the National Fire Protection Agency (NFPA), where applicable. Follow the Canadian Electric Code (CEC) in Canada.
2. The rotation of the wheel is critical. It must be free to rotate without striking or rubbing any stationary objects.
3. Motor must be securely and adequately grounded.
4. Do not spin fan wheel faster than max cataloged fan RPM. Adjustments to fan speed significantly affect motor load. If the fan RPM is changed, the motor current should be checked to make sure it is not exceeding the motor nameplate amps.
5. Do not allow the power cable to kink or come in contact with oil, grease, hot surfaces or chemicals. Replace cord immediately if damaged.
6. Verify that the power source is compatible with the equipment.
7. Never open access doors to a duct while the fan is running.

DANGER

Always disconnect, lock and tag power source before installing or servicing. Failure to disconnect power source can result in fire, shock or serious injury.

CAUTION

When servicing the fan, motor may be hot enough to cause pain or injury. Allow motor to cool before servicing.

CAUTION

Precaution should be taken in explosive atmospheres.

DANGER

Pour écarter les risques d'incendie, de choc électrique ou de blessure grave, veiller à toujours débrancher, verrouiller et étiqueter la source de courant avant l'installation ou l'entretien.

ATTENTION

Lors de toute intervention sur la soufflante, le moteur peut être suffisamment chaud pour provoquer une douleur voire une blessure. Laisser le moteur refroidir avant toute maintenance.

ATTENTION

Faire preuve de précaution dans les atmosphères explosives.

Receiving

Upon receiving the product, check to ensure all items are accounted for by referencing the delivery receipt or packing list. Inspect each crate or carton for shipping damage before accepting delivery. Alert the carrier of any damage detected. The customer will make notification of damage (or shortage of items) on the delivery receipt and all copies of the bill of lading which is countersigned by the delivering carrier. If damaged, immediately contact your Representative. Any physical damage to the unit after acceptance is not the responsibility of the manufacturer.

Unpacking

Verify that all required parts and the correct quantity of each item have been received. If any items are missing, report shortages to your local representative to arrange for obtaining missing parts. Sometimes it is not possible that all items for the unit be shipped together due to availability of transportation and truck space. Confirmation of shipment(s) must be limited to only items on the bill of lading.

Handling

Fans are to be rigged and moved by the lifting brackets provided or by the skid when a forklift is used. Location of brackets varies by model and size. Handle in such a manner as to keep from scratching or chipping the finish. Damaged finish may reduce the ability of the fan to resist corrosion.

Fans should never be lifted by the shaft, fan housing, motor, belt guard, windband or accessories.

Lifting

Lifting the fans must be done with care to avoid damaging the housing. Attach four lifting devices under the outer housing, each device beneath the vertical row of fasteners as depicted in Figure 1.

Lifting devices should be a minimum of 3 inches wide to avoid damaging the sheet metal housing.

Do not lift this model near the center of the outer housing.

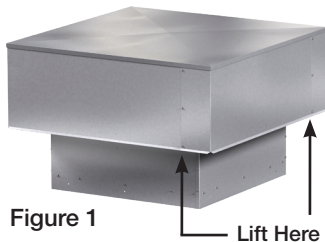

Storage

Fans are protected against damage during shipment. If the unit cannot be installed and operated immediately, precautions need to be taken to prevent deterioration of the unit during storage. The user assumes responsibility of the fan and accessories while in storage. The manufacturer will not be responsible for damage during storage. These suggestions are provided solely as a convenience to the user.

Storage Environment

The ideal environment for the storage of fans and accessories is indoors, above grade, in a low humidity atmosphere which is sealed to prevent the entry of blowing dust, rain or snow. Temperatures should be evenly maintained between 30° to 110°F (-1° to 43°C). Wide temperature swings may cause condensation and “sweating” of metal parts. All accessories must be stored indoors in a clean, dry atmosphere.

Remove any accumulations of dirt, water, ice or snow and wipe dry before moving to indoor storage. To avoid “sweating” of metal parts allow cold parts to reach room temperature. To dry parts and packages use a portable electric heater to get rid of any moisture buildup. Leave coverings loose to permit air circulation and to allow for periodic inspection.

The unit should be stored at least 3-1/2 inch off the floor on wooden blocks covered with moisture proof paper or polyethylene sheathing. Aisles between parts and along all walls should be provided to permit air circulation and space for inspection.

Fans designed for outdoor applications may be stored outdoors, if absolutely necessary. Roads or aisles for portable cranes and hauling equipment are needed.

The fan should be placed on a level surface to prevent water from leaking into the fan. The fan should be elevated on an adequate number of wooden blocks so that it is above water and snow levels and has enough blocking to prevent it from settling into soft ground. Locate parts far enough apart to permit air circulation, sunlight and space for periodic inspection. To minimize water accumulation, place all fan parts on blocking supports so that rain water will run off.

Do not cover parts with plastic film or tarps as these cause condensation of moisture from the air passing through heating and cooling cycles.

Fan wheels should be blocked to prevent spinning caused by strong winds.

Inspection and Maintenance During Storage

While in storage, inspect fans once per month. Keep a record of inspection and maintenance performed. If moisture or dirt accumulations are found on parts, the source should be located and eliminated. At each inspection, rotate the wheel by hand ten to fifteen revolutions to distribute lubricant on motor. If paint deterioration begins, consideration should be given to touch-up or repainting. Fans with special coatings may require special techniques for touch-up or repair.

Machined parts coated with rust preventive should be restored to good condition promptly if signs of rust occur. Immediately remove the original rust preventive coating with petroleum solvent and clean with lint-free cloths. Polish any remaining rust from surface with crocus cloth or fine emery paper and oil. Do not destroy the continuity of the surfaces. Thoroughly wipe clean with Tectyl® 506 (Ashland Inc.) or the equivalent. For

hard to reach internal surfaces or for occasional use, consider using Tectyl® 511M Rust Preventive, WD-40® or the equivalent.

Removing From Storage

As fans are removed from storage to be installed in their final location, they should be protected and maintained in a similar fashion until the fan equipment goes into operation.

Dimensional Data

Housing

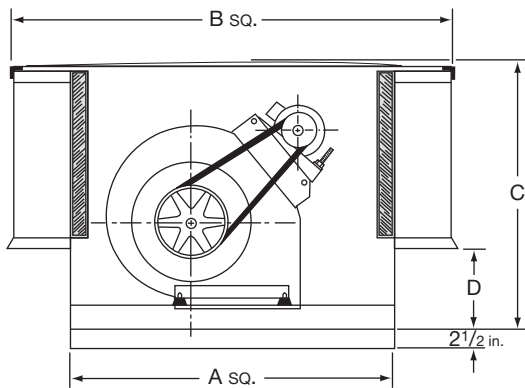

Base of Unit

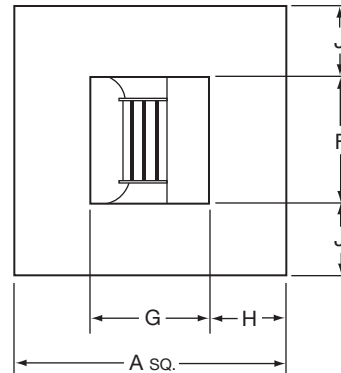

Optional Duct Adapter

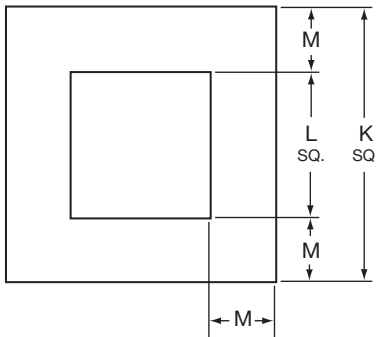

Fan Size	A SQ.	B SQ.	C	D	F	G	H	J	K SQ.	L SQ.	M	Nominal Filter	Weight
90	26	35-1/8	23-1/4	10-1/4	12-1/4	10-3/4	7-5/8	6-7/8	24-1/2	12-1/4	6-1/8	(4) 12 x 20	145
100	30	41-1/8	23-1/4	10-1/4	13-5/8	11-7/8	9-1/16	8-3/16	28-1/2	14-1/4	7-1/8	(4) 12 x 25	173
120	34	47-1/8	27-1/4	10-1/4	16-1/8	13-7/8	10-1/16	8-15/16	32-1/2	18-1/4	7-1/8	(4) 16 x 25	225
150	40	53-1/8	31-1/4	10-1/4	19-1/8	16-1/2	11-1/4	10-7/16	38-1/2	20-1/4	9-1/8	(8) 16 x 20	336
180	46	61-1/8	34-1/4	12-1/4	22-1/2	19-1/2	10-1/8	11-3/4	44-1/2	26-1/4	9-1/8	(4) 16 x 20 (4) 20 x 20	400
200	52	73-1/8	39-1/4	12-1/4	23-1/4	25-1/4	13-3/8	14-3/8	50-1/2	30-1/4	10-1/8	(8) 20 x 25	620

All dimensions in inches and weight is shown in pounds.

Typical Installation

Move the fan to its intended location and fasten it securely through mounting holes provided in the fan base. Shims may be necessary depending upon thickness of the roofing material.

For ducted applications, an optional duct adapter (if provided) is attached and holds the ductwork in place prior to installing the unit. The diagram below shows a typical installation with prefab roof curb and ductwork.

Access to the motor compartment is made by releasing the fasteners which secure the cover. The cover should be placed in an area where wind will not blow it off the roof.

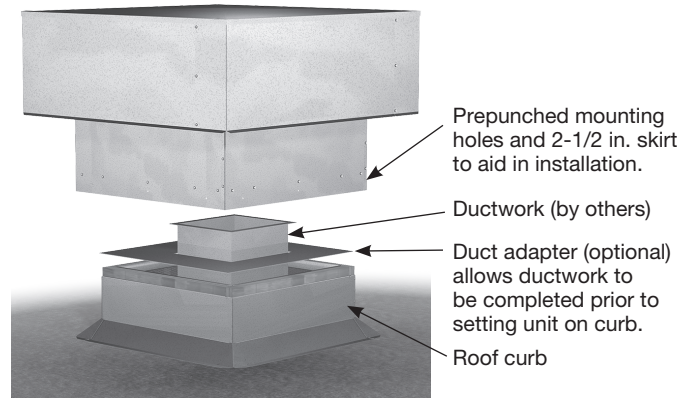

Electrical Connection

The electrical supply must be compatible with the fan motor with regard to voltage, phase and amperage capacity. Moreover, the electrical supply line must be properly fused and conform to local and national electrical codes.

Electrical lead-in wires should be routed through the pre-punched hole in the optional duct adapter (if provided) and the punched hole in the bottom of the fan housing. Electrical wires must be located so as not to rub on moving components. The electrical supply line is connected to an optional safety disconnect switch (if provided) or wired directly to the motor.

Wiring should be secured inside the fan to prevent interference with the drive components. All wiring must conform to local and national codes.

Fan Size	Recommended		Duct Size ID	Nominal Damper Size
	Curb Size*	Roof Opening		
90	24-1/2 x 24-1/2	15 x 15	12	12 x 12
100	28-1/2 x 28-1/2	17 x 17	14	14 x 14
120	32-1/2 x 32-1/2	21 x 21	18	18 x 18
150	38-1/2 x 38-1/2	23 x 23	20	20 x 20
180	44-1/2 x 44-1/2	29 x 29	26	26 x 26
200	50-1/2 x 50-1/2	33 x 33	30	30 x 30

All dimensions in inches.

* Recommended curb size shown is outside curb dimension without roofing and flashing.

Note: In cases where extreme snow depths may be encountered, taller roof curbs may be required to raise unit or condensation pans may be required in ductwork.

Mounting for Seismic Installation

IMPORTANT

Installation instructions for seismic ratings are only recommendations. Final design must be determined by Structural Engineer of Record (SEOR) including requirements for curb construction, mounting of unit to curb and mounting of curb to structure.

	Fan Size	Fasteners per side	Total Fasteners
Steel	90, 100, 120	3	6
	150	4	8
	180, 200	5	10
Concrete	90, 100, 200	3	6
	150	4	8
	180, 200	5	10
Timber	90, 100, 120	3	6
	150	4	8
	180, 200	5	10

All dimensions are in inches.

Mounting for High Wind Installation

Fan to Curb: Three (3) fasteners are required per side on all sides. Must be equally spaced.

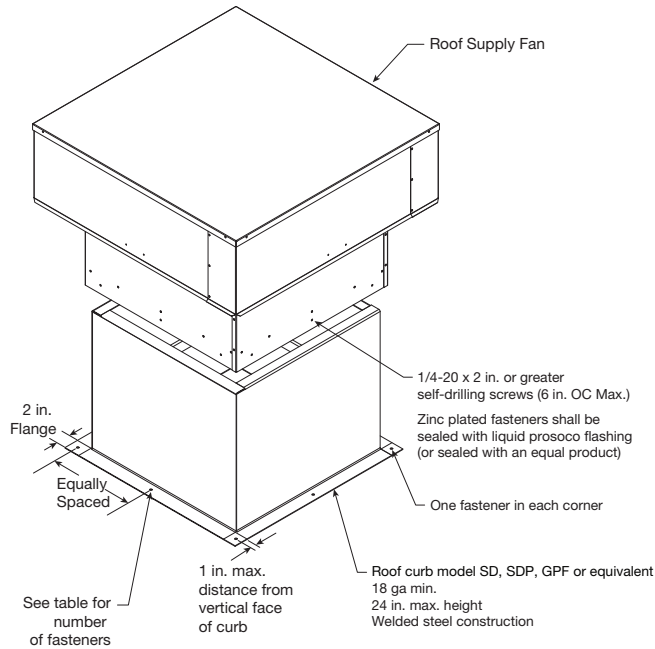

Curb to Deck:

STEEL ANCHORING

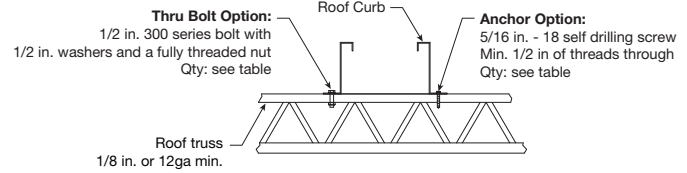

CONCRETE DECK ANCHORING

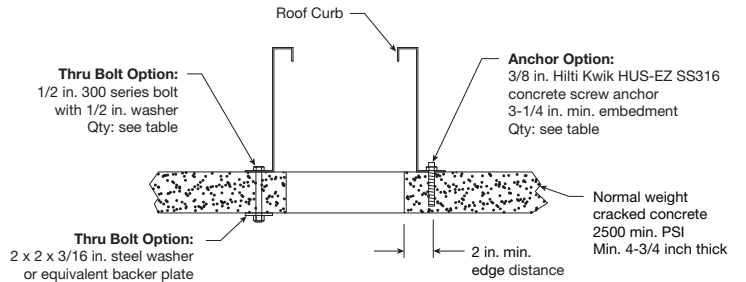

TIMBER ANCHORING

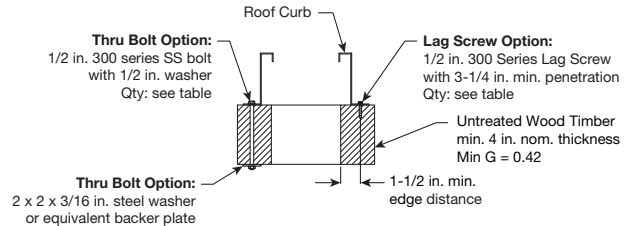

High Wind Rating Anchoring

	Fan Size	Lag Screws/Anchors					Thru Bolts				
		Min. Edge Distance	Fastener Type	Fastener Size	Fasteners Per Side*	Fasteners Total	Min. Edge Distance	Fastener Type	Fastener Size	Fasteners Per Side	Fasteners Total
Steel	90, 100, 120	0.625	300 Series SS Self-Drilling Screw with a min. of 1/2 inch Threads Through	5/16-18	0	4	1	300 Series SS Bolt with 1/2 inch Washer	1/2	0	4
	150, 180, 200				1	8					
Concrete	90, 100, 120, 150	2	Hilti HUS-EZ SS316 Concrete Screw Anchor	3/8	0	4	2	300 Series SS Bolt with 1/2 inch Washer	1/2	0	4
	180, 200				1	8					
Timber	90, 100, 120	1.5	300 Series SS Lag Screw with 3.25 inch min. penetration into wood	1/2	0	4	1.5	300 Series SS Bolt with 1/2 inch Washer	1/2	0	4
	150, 180, 200				1	8					

All dimensions are in inches.

*Fasteners must be placed in all 4 corners in all applications. Zinc Plated Grade 2 Steel fasteners can be used in place of SS fasteners but they must be sealed with liquid Prosoco flashing (or an equal product). All fasteners to be installed per the manufacturer recommendations.



Pre-Start-Up Checks

DANGER

Disconnect and secure to the “off” position all electrical power to the fan prior to inspection or servicing. Failure to comply with this safety precaution could result in serious injury or death.

DANGER

Pour écarter les risques de blessure grave ou de mort, débrancher et verrouiller l’alimentation électrique en position « Arrêt » avant tout contrôle ou entretien.

Units with motor and drives shipped separate, refer to Motor Mounting Instructions included in hardware bag.

Check all fasteners and set screws for tightness. Rotate the fan wheel by hand to assure it turns freely and is centered between the inlets. Check pulleys and belts for proper alignment to avoid premature belt wear, noise, vibration and power loss. Motor and fan pulleys must be parallel and in alignment, see Figure 2.

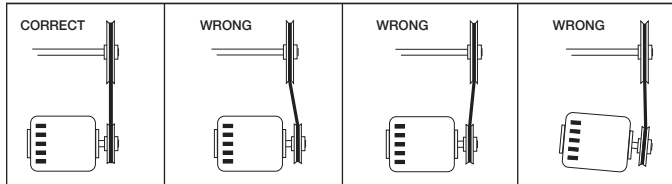

Figure 2

Adjustable motor pulley is set at the factory for the fan RPM specified. Fan speed can be increased by closing or decreased by opening the adjustable motor pulley. Two groove variable pitch pulleys must be adjusted an equal number of turns open. Any increase in fan speed results in an increase in horsepower required for the motor. Motor amperage should always be checked and compared to nameplate rating when changing fan speed.

Direction of fan wheel rotation is critical. A fan wheel rotating in the wrong direction will result in reduced airflow, motor overloading and possible burnout. Check wheel rotation by momentarily turning the fan on.

Rotation should be in the same direction as airflow at the outlet. See housing and wheel example in Figure 3.

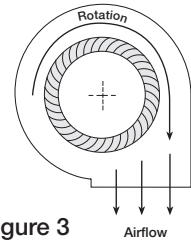

Figure 3

IMPORTANT

Supply fans should be operated only when attached to the completed system. Without proper static pressure loading, the motor may be overloaded and burnout may occur.

Maintenance

DANGER

Disconnect and secure to the “off” position all electrical power to the fan prior to inspection or servicing. Failure to comply with this safety precaution could result in serious injury or death.

DANGER

Pour écarter les risques de blessure grave ou de mort, débrancher et verrouiller l'alimentation électrique en position « Arrêt » avant tout contrôle ou entretien.

To preserve the reliability and performance designed into the fan, regularly scheduled maintenance should be performed. Items to be checked at each maintenance interval are filters, belts, bearings, fasteners, lubrication and removal of dust and dirt.

Filters

One-inch washable aluminum mesh filters are standard on both models. Optional two-inch filters may be supplied on some fans. Filters should be cleaned on a regular basis for optimum efficiency.

To remove the filters, first remove the fan cover by removing the hex head 5/16 inch bolts. Place the cover in an area where wind will not blow it off the roof. The filters can be lifted out and washed in a mild detergent solution. If desired, an adhesive spray available at most filter distributors can be applied to increase filter efficiency.

Belts

Belt tension should be checked two times during the first 24 hours of operation and during each scheduled maintenance thereafter. Premature belt failures are frequently caused by improper belt tension, either too tight or loose. The proper belt tension for operating a V-belt is the lowest tension at which the belt will not slip at peak load conditions. For initial tensioning, belt deflection should be 1/64 inch for each inch of belt span, determined by using moderate thumb pressure half way between pulley centers. For example, the belt deflection should be 1/2 inch if the belt span is 32 inches, see Figure 4.

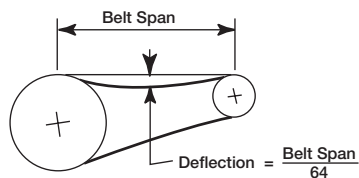

Figure 4

Belt tension can be adjusted by loosening the motor plate hinge bolts and adjusting the jack screws as required. All units are supplied with either a painted steel motor bracket or a galvanized motor plate for

larger motor frames. To adjust belt tension on units equipped with the painted steel motor bracket, simply adjust the single jack screw.

For units equipped with a galvanized motor plate, both jack screws must be adjusted equally. Check pulley and belt alignment after adjusting belt tension; Figure 2.

Lubrication

Fan bearings on all models are permanently lubricated. Motor bearings equipped with grease fittings should be lubricated in accordance with instructions on the motor nameplate. Motors without grease fittings are lubricated for life.

Cleaning

Motors and fan wheels require periodic cleaning to remove dust and dirt which may accumulate. Motor cleaning should be limited to the exterior surface only. Removing dust and dirt from the motor housing assists in motor cooling and prolongs motor life. Motors should never be sprayed with steam, water or solvents.

Fan wheels which are left to accumulate dust and dirt will have poor air performance, loss of efficiency and possible damaging vibration due to an unbalanced condition.

Periodic cleaning is a good investment in preserving the reliability and performance designed into the fan.

Parts List

Each fan bears a manufacturer's nameplate with model number and serial number embossed. This information will assist the local representative and the factory in providing service and replacement parts. Before taking any corrective action, make certain unit is not capable of operation during repairs.

CAUTION

A fan manufactured with an explosion resistant motor does not certify the entire unit to be explosion proof. Refer to UL Listing Mark for the fans approved usage.

CAUTION

La présence d'un moteur antidéflagrant sur un ventilateur ne garantit pas que tout l'appareil est antidéflagrant. Pour connaître les emplois autorisés de l'appareil, voir son marquage de conformité UL.

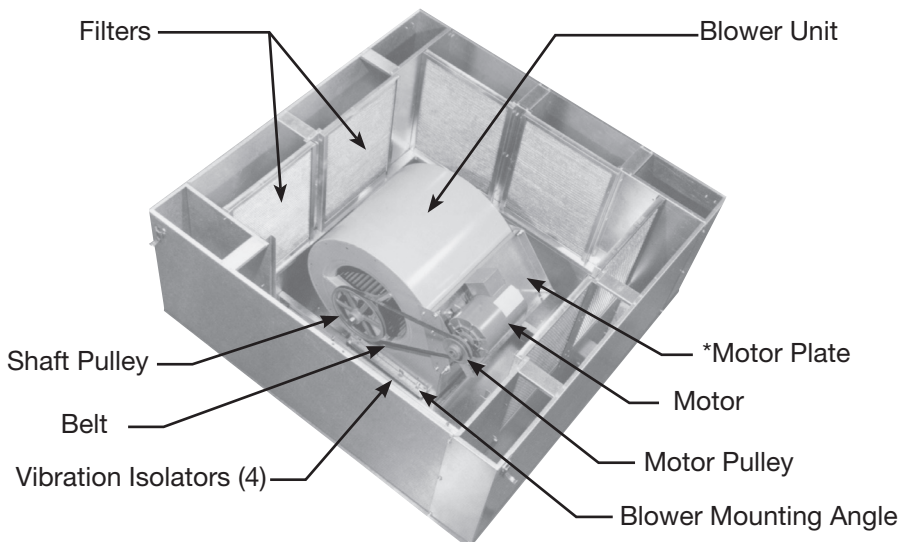

*Galvanized motor plate shown. Painted steel motor bracket used on units with smaller motor frame sizes.

Our Commitment

As a result of our commitment to continuous improvement, Greenheck reserves the right to change specifications without notice.

Product warranties can be found online at Greenheck.com, either on the specific product page or in the literature section of the website at Greenheck.com/Resources/Library/Literature.

Greenheck's Centrifugal Roof Supply Fans catalog provides additional information describing the equipment, fan performance, available accessories, and specification data.

AMCA Publication 410-96, Safety Practices for Users and Installers of Industrial and Commercial Fans, provides additional safety information. This publication can be obtained from AMCA International, Inc. at www.amca.org.

