

Installation, Operation and Maintenance Manual

Please read and save these instructions for future reference. Read carefully before attempting to assemble, install, operate or maintain the product described. Protect yourself and others by observing all safety information. Failure to comply with these instructions will result in voiding of the product warranty and may result in personal injury and/or property damage.

Low Silhouette Exhaust Fans

These belt drive centrifugal roof exhaust fans provide the industry's best performance and durability for general clean air applications. Fans are available in hinged fabra hood style.



General Safety Information

Only qualified personnel should install this fan. Personnel should have a clear understanding of these instructions and should be aware of general safety precautions. Improper installation can result in electric shock, possible injury due to coming in contact with moving parts, as well as other potential hazards. Other considerations may be required if high winds or seismic activity are present. If more information is needed, contact a licensed professional engineer before moving forward.

1. Follow all local electrical and safety codes, as well as the National Electrical Code (NEC) and the National Fire Protection Agency (NFPA), where applicable. Follow the Canadian Electrical Code (CEC) in Canada.
2. The rotation of the wheel is critical. It must be free to rotate without striking or rubbing any stationary objects.
3. Motor must be securely and adequately grounded.
4. Do not spin fan wheel faster than max cataloged fan RPM. Adjustments to fan speed significantly affects motor load. If the fan RPM is changed, the motor current should be checked to make sure it is not exceeding the motor nameplate amps.
5. Do not allow the power cable to kink or come in contact with oil, grease, hot surfaces, or chemicals. Replace cord immediately if damaged.
6. Verify that the power source is compatible with the equipment.
7. Never open access doors to a duct while the fan is running.

DANGER

Always disconnect, lock and tag power source before installing or servicing. Failure to disconnect power source can result in fire, shock or serious injury.

CAUTION

When servicing the fan, motor may be hot enough to cause pain or injury. Allow motor to cool before servicing.

CAUTION

Precaution should be taken in explosive atmospheres.

DANGER

Pour écarter les risques d'incendie, de choc électrique ou de blessure grave, veiller à toujours débrancher, verrouiller et étiqueter la source de courant avant l'installation ou l'entretien.

ATTENTION

Lors de toute intervention sur la soufflante, le moteur peut être suffisamment chaud pour provoquer une douleur voire une blessure. Laisser le moteur refroidir avant toute maintenance.

ATTENTION

Faire preuve de précaution dans les atmosphères explosives.

Receiving

Upon receiving the product, check to ensure all items are accounted for by referencing the delivery receipt or packing list. Inspect each crate or carton for shipping damage before accepting delivery. Alert the carrier of any damage detected. The customer will make notification of damage (or shortage of items) on the delivery receipt and all copies of the bill of lading which is countersigned by the delivering carrier. If damaged, immediately contact your Representative. Any physical damage to the unit after acceptance is not the responsibility of the manufacturer.

Unpacking

Verify that all required parts and the correct quantity of each item have been received. If any items are missing, report shortages to your local representative to arrange for obtaining missing parts. Sometimes it is not possible that all items for the unit be shipped together due to availability of transportation and truck space. Confirmation of shipment(s) must be limited to only items on the bill of lading.

Handling

When lifting the unit to the roof, securely fasten straps to the drive frame located in the motor compartment. Access to the motor compartment is accomplished by removing bolts securing the hood to the base. The hood cover will need to be removed for access to the drive frame. The cover can then be removed and placed on a flat surface in an area protected from strong winds.

When unit is on the roof, move fan to desired location and fasten securely through mounting holes in base. Shims may be necessary depending upon roof material thickness.

The motor amperage and voltage ratings must be checked for compatibility to supply voltage prior to final electrical connection. Electrical lead-in wires should be run through the conduit provided between the curb and the bottom of the motor compartment. Wiring must conform to local and national codes.

IMPORTANT

Do not lift by the fan hood. Avoid lifting fans in a way that will bend or distort fan parts. Never pass slings or timbers through the venturi of fan. Fans with special coatings or paints must be protected in handling to prevent damage.

Storage

Fans are protected against damage during shipment. If the unit cannot be installed and operated immediately, precautions need to be taken to prevent deterioration of the unit during storage. The user assumes responsibility of the fan and accessories while in storage. The manufacturer will not be responsible for damage during storage. These suggestions are provided solely as a convenience to the user.

Indoor

The ideal environment for the storage of fans and accessories is indoors, above grade, in a low humidity atmosphere which is sealed to prevent the entry of blowing dust, rain or snow. Temperatures should be evenly maintained between 30° to 110°F (-1° to 43°C), wide temperature swings may cause condensation and “sweating” of metal parts. All accessories must be stored indoors in a clean, dry atmosphere.

Remove any accumulations of dirt, water, ice, or snow and wipe dry before moving to indoor storage. To avoid “sweating” of metal parts allow cold parts to reach room temperature. To dry parts and packages, use a portable electric heater to remove any moisture build up. Leave coverings loose to permit air circulation and to allow for periodic inspection.

The unit should be stored at least 3½ inches (89 mm) off the floor on wooden blocks covered with moisture proof paper or polyethylene sheathing. Aisles between parts and along all walls should be provided to permit air circulation and space for inspection.

Outdoor

Fans designed for outdoor applications may be stored outdoors, if absolutely necessary. Roads or aisles for portable cranes and hauling equipment are needed.

The fan should be placed on a level surface to prevent water from leaking into the fan. The fan should be elevated on an adequate number of wooden blocks so it is above water and snow levels and has enough blocking to prevent it from settling into soft ground. Locate parts far enough apart to permit air circulation, sunlight and space for periodic inspection. To minimize water accumulation, place all fan parts on blocking supports so rain water will run off.

Do not cover parts with plastic film or tarps as these cause condensation of moisture from the air passing through heating and cooling cycles. Fan wheels should be blocked to prevent spinning caused by strong winds.

Inspection and Maintenance During Storage

While in storage, inspect fans once per month. Keep a record of inspection and maintenance performed.

If moisture or dirt accumulations are found on parts, the source should be located and eliminated. At each inspection, rotate the wheel by hand ten to fifteen revolutions to distribute lubricant on motor. If paint deterioration begins, consideration should be given to touch-up or repainting. Fans with special coatings may require special techniques for touch-up or repair.

Machined parts coated with rust preventive should be restored to good condition promptly if signs of rust occur. Immediately remove the original rust preventive coating with petroleum solvent and clean with lint-free cloths. Polish any remaining rust from surface with crocus cloth or fine emery paper and oil. Do not destroy the continuity of the surfaces. Thoroughly wipe clean

with Tectyl® 506 (Ashland Inc.) or the equivalent. For hard to reach internal surfaces or for occasional use, consider using Tectyl® 511M Rust Preventive, WD-40® or the equivalent.

Removing From Storage

As fans are removed from storage to be installed in their final location, they should be protected and maintained in a similar fashion until the fan equipment goes into operation.

Dimensional Data

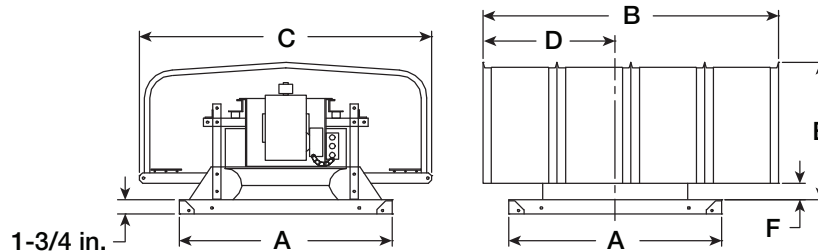

Fan Size	A	B	C	D	E	F	Damper Size	Recommended Roof Opening	Max. Fan Weight [^]
14	26	39	35	17-1/2	18	4	16	18-1/2	81
18	30	39	40	17-1/2	21	4-1/2	18	20-1/2	135
21	30	51	43	23	23	6	18	20-1/2	145
24	34	51	45-1/2	20-1/2	23-1/2	6-3/4	24	26-1/2	188
30	40	63	50	29-1/2	26-5/8	8-1/2	30	32-1/2	249
36	46	63	60	27	32-5/8	9-3/4	36	38-1/2	338
42	52	75	70-5/8	33-1/2	37-3/8	11-1/2	42	44-1/2	396
48	58	87	70-3/8	41	41-1/2	11-5/8	48	50-1/2	430
54	64	87	79-1/2	38	45-3/8	12-1/2	54	56-1/2	596

All dimensions in inches and weight is shown in pounds. [^]Weight shown is standard galvanized construction and largest cataloged totally enclosed motor.

Pre Start-Up Checks

1. Check all fasteners for tightness. The wheel should rotate freely and be aligned as shown in Figure 1.

Fan Sizes	G - Overlap (in.)
14	1/4
18-24	3/8
30-54	1/2

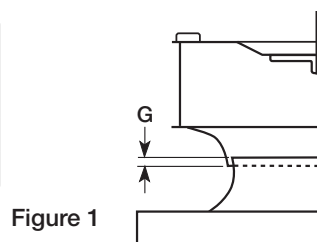

Figure 1

2. Wheel position is preset and the unit is test run at the factory. Movement may occur during shipment and realignment may be necessary.
3. Centering can be accomplished by loosening the bolts holding the drive frame to the shock mounts and repositioning the drive frame.
4. Wheel and inlet cone overlap can be adjusted by movement of the wheel. See Tapered Bushing Hub Installation and Removal (page 5) for directions on repositioning.

5. Check wheel rotation by momentarily energizing the unit. Rotation should be clockwise as shown in Figure 2 and correspond to the rotation decal on the unit. Rotation is determined when the unit is viewed from the motor or shaft pulley side.

Fans have clockwise (CW) wheel rotation when viewed from top of fan.

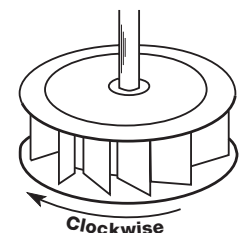

Figure 2

WARNING

Correct direction of wheel rotation is critical. Reversed rotation will result in poor air performance, motor overloading and possible motor burnout.

AVERTISSEMENT

La turbine doit impérativement tourner dans le bon sens. Une rotation en sens inverse entraînerait de mauvaises performances de soufflage, une surcharge du moteur voire un grillage du moteur.

Prestart-up Belt Tension Checks

1. Always loosen tension enough to install belt without stretching, see Figure 3.

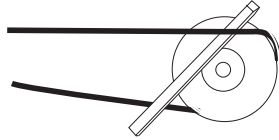

Do not force belt(s). Forcing the belt(s) will break the cords and cause belt failure

Figure 3

2. If adjustments are made, it is very important to check the pulleys for proper alignment. Misaligned pulleys lead to excessive belt wear vibration, noise and power loss, see Figure 4.

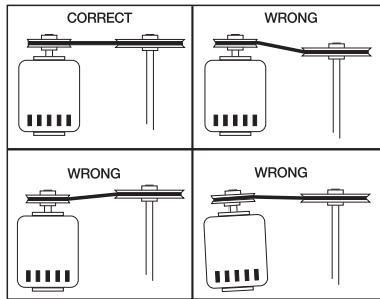

Figure 4

3. Belt tension can be adjusted by loosening four fasteners (marked “R” in Figure 5) on the drive frame. This allows the motor plate to slide on the drive frame angles for proper positioning.

Identical fasteners on opposing side must also be loosened.

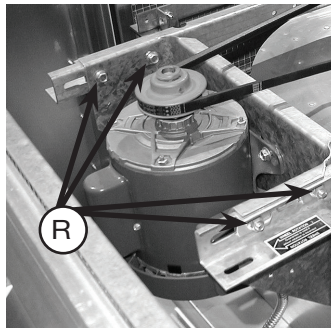

Figure 5

4. Belt tension should be adjusted to allow 1/64 inch of deflection per inch of belt span. For example, a 15 inch (381 mm) belt span should have 15/64 inch (or about 1/4 inch) of deflection with moderate thumb pressure at mid-point between pulleys, see Figure 6.

IMPORTANT

The fan has been checked for mechanical noises at the factory prior to shipment. If mechanical noise should develop, suggested corrective actions are offered in the Troubleshooting section.

IMPORTANT

Over tightening will cause excessive bearing wear and noise. Too little tension will cause slippage at start-up and uneven wear.

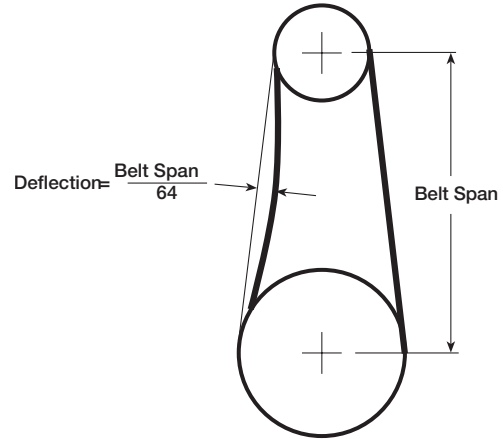

Figure 6

5. The adjustable motor pulley is factory set for the RPM specified. Speed can be increased by closing or decreased by opening the adjustable motor sheave.
6. Two groove variable pitch pulleys must be adjusted an equal number of turns open or closed.
7. Any increase in speed represents a substantial increase in the horsepower required by a unit.
8. Motor amperage should always be checked to avoid serious damage to the motor when speed is varied.

IMPORTANT

Adjust (tighten) belt tension after the first 24-48 hours of operation.

Maintenance

WARNING

Always disconnect, lock and tag power source before servicing. Failure to disconnect power source can result in fire, shock or serious injury.

AVERTISSEMENT

Pour écarter les risques d'incendie, de choc électrique ou de blessure grave, veiller à toujours débrancher, verrouiller et étiqueter la source de courant avant l'entretien.

IMPORTANT

Uneven cleaning of the wheel will produce an out of balance condition that will cause vibration in the fan.

WARNING

This unit should be made non-functional when cleaning the wheel or housing (fuses removed, disconnect locked off).

AVERTISSEMENT

L'appareil doit être rendu non opérationnel lors du nettoyage de la turbine ou du caisson (fusibles retirés, sectionneur verrouillé).

Motor maintenance is generally limited to cleaning and lubrication (where applicable). Cleaning should be limited to exterior surfaces only. Removing dust buildup on motor housing ensures proper motor cooling.

Greasing of motors is only intended when fittings are provided. Many fractional hp motors are permanently lubricated and should not be lubricated further. Motors supplied with grease fittings should be greased in accordance with manufacturers' recommendations. Where motor temperatures do not exceed 104°F (40°C), the grease should be replaced after 2000 hours of running time as a general rule.

Wheels require very little attention when moving clean air. Occasionally, oil and dust may accumulate causing imbalance. When this occurs, the wheel and housing should be cleaned to ensure smooth and safe operation.

All fasteners should be checked for tightness each time maintenance checks are performed prior to restarting unit.

A proper maintenance program will help these units deliver years of dependable service.

Tapered Bushing Hub Installation and Removal

All For wheel hubs and shaft pulleys utilizing a tapered bushing interface, follow this procedure for installation and removal. There are two possible set ups for the tapered bushing, both have the same procedure, but orientation of the hub varies.

Tapered Bushing Removal

1. (If present): Loosen the setscrew holding the bushing and shaft key in place.
2. Loosen and remove the socket head cap screws fastening the bushing to the hub as shown in the section views and examples of Figures 7-10

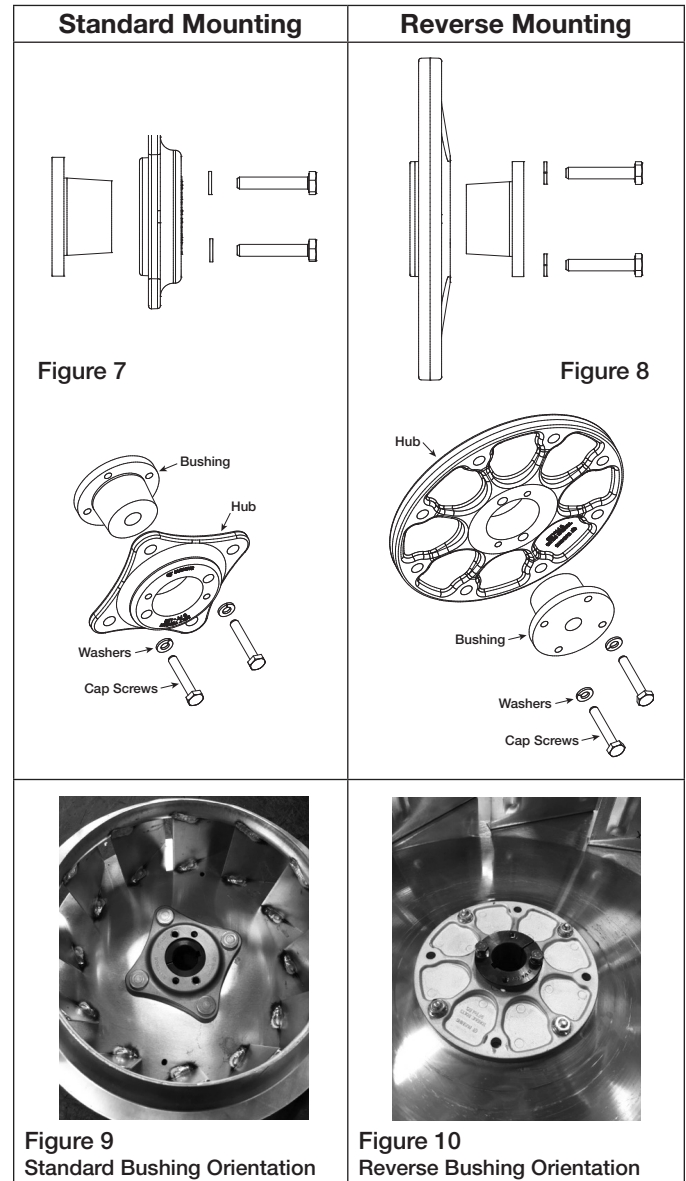

3. **Standard Mounting:** Take the two socket head cap screws that were removed and install into the visibly threaded holes on the wheel hub.

Reverse Mounting: Install the two socket head cap screws into the visibly threaded holes of the bushing flange.

4. Once both socket head cap screws are installed, tighten them an eighth of a turn at a time, alternating between the two until the hub loosens from the bushing.

Bushing Installation

1. Clean all surfaces of hub and bushing to remove any oil or residue present and do not use any lubricant to install bushing into the hub. For both standard and reverse mounting styles, the socket head cap screws are adjustable from the inlet of the fan.
2. **Standard Mounting:** Slide the bushing and shaft key onto the fan shaft followed by the wheel and hub assembly. If present, use the keyway setscrew to hold the shaft key and bushing in place but **DO NOT** overtighten as this can damage the bushing. Align the unthreaded holes of the hub with the threaded holes of the tapered bushing.
Reverse Mounting: Slide the wheel and hub assembly onto the fan shaft followed by the bushing and shaft key. If present, use the keyway setscrew to hold the shaft key and bushing in place but **DO NOT** overtighten as this can damage the bushing. Align the unthreaded holes of the tapered bushing with the threaded holes of the hub.
3. Install the two bushing socket head cap screws into the aligned holes by hand (or without excessive torque) until the heads of the socket head cap screws are seated against the mating surface.
4. Adjust the height of the wheel in the fan relative to the inlet venturi then tighten the two socket head cap screws an eighth turn at a time in an alternating fashion and to a torque of 10 ft-lbs.

Belt/Bearing Maintenance

1. Belts tend to stretch after a period of time. They should be checked periodically for wear and tightness. When replacing belts, use the same type as supplied with the unit.
2. Matched belts should always be used on units with multi-groove pulleys.
3. For belt replacement, loosen the tensioning device far enough to allow removal of the belt by hand. Do not force belts on or off. This may cause cords to break, leading to premature belt failure.
4. Once installed, adjust belts as shown in “Pre-Starting Checks.”
5. Shaft bearings can be classified in two groups: relubricating and non-relubricating. All bearings are factory lubricated and require no further lubrication under normal use (between -20°F and 180°F (-29° to 82°C) in a relatively clean environment).
6. Units installed in hot, humid, or dirty locations should be equipped with special bearings. These bearings will require frequent lubrication. Caution should be employed to prevent overpacking or contamination.
7. Grease fittings should be wiped clean. The unit should be in operation while lubricating. Use extreme care around moving parts.
8. Grease should be pumped in very slowly until a slight bead forms around the seal. A high-grade lithium base grease is recommended.

Troubleshooting

WARNING

Before taking any corrective action, make certain unit is not capable of operation during repairs.

AVERTISSEMENT

Avant d'entreprendre toute action corrective, s'assurer que l'appareil ne pourra pas fonctionner durant les réparations.

PROBLEM	CAUSE	CORRECTIVE ACTION
Reduced Airflow	System resistance too high	Check system for proper operation of backdraft or control dampers; remove obstructions in ductwork, etc.
	Unit running backwards	See Pre-Starting Checks.
	Fan speed too low	Increase fan speed.
	Excessive dirt buildup on wheel	Clean wheel.
	Improper wheel alignment	Center wheel on inlets.
Excessive Noise or Vibration	Bearings	Replace defective bearing(s). Lubricate bearing(s)
	Belts too tight or too loose	Refer to Figure 6 and adjust tension.
	Wheel improperly aligned and rubbing	Center wheel on inlets, see Figure 1.
	Loose drive or motor pulleys	Align and tighten. See Pre-Starting Checks.
	Foreign objects in wheel or housing	Remove objects, check for damage or unbalance.
	Unbalance of wheel caused by excessive dirt and grease buildup	Remove buildup.

Parts List

Each fan bears a manufacturer's nameplate with model number and serial number embossed. This information will assist the local representative and the factory in providing service and replacement parts. Before servicing, assure unit is not capable of operation during repairs.

CAUTION
 A fan manufactured with an explosion resistant motor does not certify the entire unit to be explosion proof. Refer to UL Listing Mark for the fans approved usage.

CAUTION
 La présence d'un moteur antidéflagrant sur un ventilateur ne garantit pas que tout l'appareil est antidéflagrant. Pour connaître les emplois autorisés de l'appareil, voir son marquage de conformité UL.

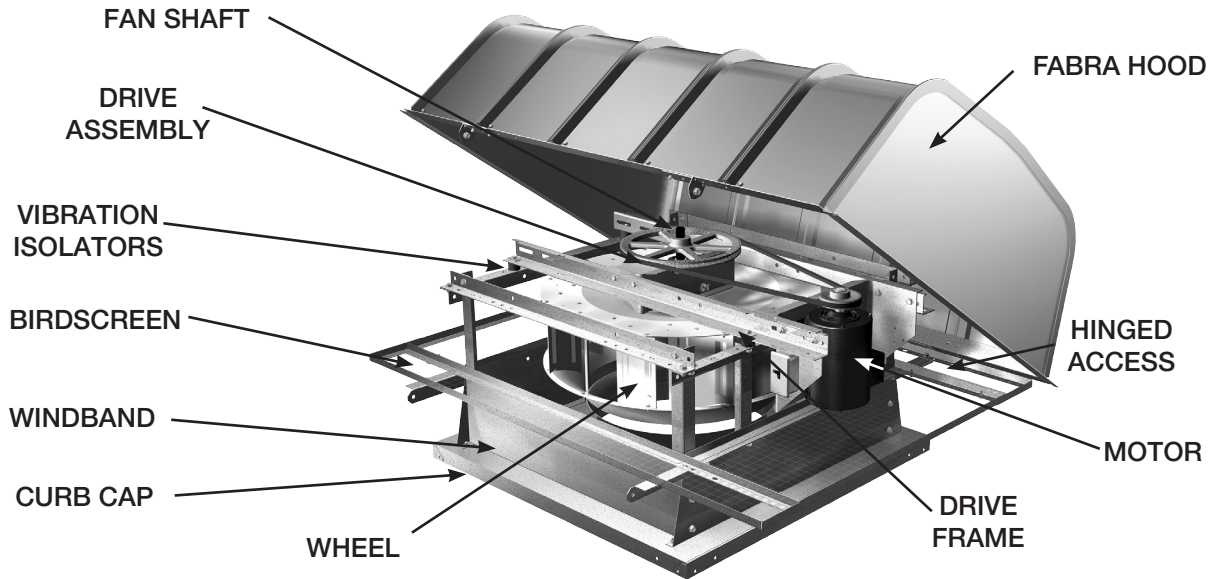

Maintenance Log

Date _____ Time _____ AM/PM
 Notes: _____

Date _____ Time _____ AM/PM
 Notes: _____

Date _____ Time _____ AM/PM
 Notes: _____

Date _____ Time _____ AM/PM
 Notes: _____

Our Commitment

As a result of our commitment to continuous improvement, Greenheck reserves the right to change specifications without notice.

Specific Greenheck product warranties are located on greenheck.com within the product area tabs and in the Library under Warranties.

Greenheck Centrifugal Roof Exhaust Fans catalog provides additional information describing the equipment, fan performance, available accessories, and specification data.

AMCA Publication 410-96, Safety Practices for Users and Installers of Industrial and Commercial Fans, provides additional safety information. This publication can be obtained from AMCA International, Inc. at www.amca.org.

