

Installation, Operation and Maintenance Manual

Please read and save these instructions for future reference. Read carefully before attempting to assemble, install, operate or maintain the product described. Protect yourself and others by observing all safety information. Failure to comply with these instructions will result in voiding of the product warranty and may result in personal injury and/or property damage.



TAUB

General Safety Information

Only qualified personnel should install this fan. Personnel should have a clear understanding of these instructions and should be aware of general safety precautions. Improper installation can result in electric shock, possible injury due to coming in contact with moving parts, as well as other potential hazards. Other considerations may be required if seismic activity is present. If more information is needed, contact a licensed professional engineer before moving forward.

1. Follow all local electrical and safety codes, as well as the National Electrical Code (NEC) and the National Fire Protection Agency (NFPA), where applicable. Follow the Canadian Electric Code (CEC) in Canada.
2. The rotation of the propeller is critical. It must be free to rotate without striking or rubbing any stationary objects.
3. Motor must be securely and adequately grounded.
4. Do not spin fan propeller faster than max cataloged fan RPM. Adjustments to fan speed with a Variable Frequency Drive (VFD) may affect motor load. If the fan RPM is changed, the motor current should be checked to make sure it is not exceeding the motor nameplate amps.
5. Do not allow the power cable to kink or come in contact with oil, grease, hot surfaces or chemicals. Replace cord immediately if damaged.
6. Verify that the power source is compatible with the equipment.

7. Never open access doors to a duct while the fan is running.

DANGER

Always disconnect, lock and tag power source before installing or servicing. Failure to disconnect power source can result in fire, shock or serious injury.

CAUTION

When servicing the fan, motor may be hot enough to cause pain or injury. Allow motor to cool before servicing.

CAUTION

Precaution should be taken in explosive atmospheres.

DANGER

Pour écarter les risques d'incendie, de choc électrique ou de blessure grave, veiller à toujours débrancher, verrouiller et étiqueter la source de courant avant l'installation ou l'entretien.

ATTENTION

Lors de toute intervention sur la soufflante, le moteur peut être suffisamment chaud pour provoquer une douleur voire une blessure. Laisser le moteur refroidir avant toute maintenance.

ATTENTION

Faire preuve de précaution dans les atmosphères explosives.

Receiving

Upon receiving the product, check to ensure all items are accounted for by referencing the delivery receipt or packing list. Inspect each crate or carton for shipping damage before accepting delivery. Alert the carrier of any damage detected. The customer will make a notation of damage (or shortage of items) on the delivery receipt and all copies of the bill of lading which is countersigned by the delivering carrier. If damaged, immediately contact your local representative. Any physical damage to the unit after acceptance is not the responsibility of manufacturer.

Unpacking

Verify that all required parts and the correct quantity of each item have been received. If any items are missing, report shortages to your local representative to arrange for obtaining missing parts. Sometimes it is not possible that all items for the unit be shipped together due to availability of transportation and truck space. Confirmation of shipment(s) must be limited to only items on the bill of lading.

Handling

Fans are to be rigged and moved by the lifting brackets provided or by the skid when a forklift is used. Location of brackets varies by model and size. Handle in such a manner as to keep from scratching or chipping the coating. Damaged finish may reduce the ability of the fan to resist corrosion. Fans should never be lifted by the fan housing, motor, motor cover, windband or accessories.

Storage

- Rotate propeller monthly and purge bearings once every three months.
- Energize fan motor once every three months.
- Store belts flat to keep them from warping and stretching.
- Store unit in a location which does not have vibration.
- After storage period, purge grease before putting fan into service.

If storage of fan is in a humid, dusty or corrosive atmosphere, rotate the fan and purge the bearings once a month. Improper storage which results in damage to the fan will void the warranty.

Fans are protected against damage during shipment. If the unit cannot be installed and operated immediately, precautions need to be taken to prevent deterioration of the unit during storage. The user assumes responsibility of the fan and accessories while in storage. The manufacturer will not be responsible for damage during storage. These suggestions are provided solely as a convenience to the user.

INDOOR - The ideal environment for the storage of fans and accessories is indoors, above grade, in a low humidity atmosphere which is sealed to prevent the entry of blowing dust, rain or snow. Temperatures should be evenly maintained between 30° to 110°F (-1° to 43°C), wide temperature swings may cause condensation and “sweating” of metal parts. All accessories must be stored indoors in a clean, dry atmosphere.

Remove any accumulations of dirt, water, ice, or snow and wipe dry before moving to indoor storage. To avoid “sweating” of metal parts allow cold parts to reach room temperature. To dry parts and packages use a portable electric heater to remove any moisture buildup. Leave coverings loose to permit air circulation and to allow for periodic inspection.

The unit should be stored at least 3½ inches (89 mm) off the floor on wooden blocks covered with moisture proof paper or polyethylene sheathing. Aisles between parts and along all walls should be provided to permit air circulation and space for inspection.

OUTDOOR - Fans designed for outdoor applications may be stored outdoors, if absolutely necessary. Roads or aisles for portable cranes and hauling equipment are needed.

The fan should be placed on a level surface to prevent water from leaking into the fan. The fan should be elevated on an adequate number of wooden blocks so it is above water and snow levels and has enough blocking to prevent it from settling into soft ground.

Locate parts far enough apart to permit air circulation, sunlight and space for periodic inspection. To minimize water accumulation, place all fan parts on blocking supports so rain water will run off.

Do not cover parts with plastic film or tarps as these cause condensation of moisture from the air passing through heating and cooling cycles.

Inspection and Maintenance During Storage

While in storage, inspect fans once per month. Keep a record of inspection and maintenance performed.

If moisture or dirt accumulations are found on parts, the source should be located and eliminated. At each inspection, rotate the fan propeller by hand ten to fifteen revolutions to distribute lubricant in motor and bearings. Every three months, the fan motor should be energized. If paint deterioration begins, consideration should be given to touch-up or repainting. Fans with special coatings may require special techniques for touch-up or repair.

Machined parts coated with rust preventive should be restored to good condition promptly if signs of rust occur. Immediately remove the original rust preventive coating with petroleum solvent and clean with lint-free cloths. Polish any remaining rust from surface with crocus cloth or fine emery paper and oil. Do not destroy the continuity of the surfaces. Thoroughly

wipe clean with Tectyl® 506 (Ashland Inc.) or the equivalent. For hard to reach internal surfaces or for occasional use, consider using Tectyl® 511M Rust Preventive, WD-40® or the equivalent.

Removing from Storage

As fans are removed from storage to be installed in their final location, they should be protected and maintained in a similar fashion until the fan equipment goes into operation.

Prior to assembly and installation of the unit and system components, inspect the fan assembly to make sure it is in working order.

1. Check all fasteners, set screws on the fan, propeller, bearings, drive, motor base and accessories for tightness.
2. Rotate the fan propeller by hand and assure no parts are rubbing.
3. Fans should not be lifted by the fan housing, motor, motor cover, windband or accessories.

Table of Contents

General Safety Information	1
Receiving, Unpacking, Handling, Storage	2
Inspection and Maintenance During Storage	2-3
Removing from Storage	3
General Information	
Unit and System Identification Tags	4
Pre-Installation Information	4
Electrical Disconnects	4
Moving Parts	4
Guards - Motor Cover or Inlet Guard	4
Inspection Door	4
Air Pressure and Suction	4
Fans - Rigging and Lifting	5
Electrical Connections	5
UL/cUL Listed Smoke Exhaust	6
Unit Start-Up	
Visual Inspection of Equipment	7
Check	7
Additional Steps for Initial Start-Up	7
Electrical Connections	7
Routine Maintenance and Operation	
Fan Operation	8
Motors	8
Fasteners and Set Screws	8
Direct Drive Fans	8
Belt Drive Fans	8-9
V-Belt Replacement	9
Alignment of Pulleys and Belts	9
Field Coating Touch-Up Procedure for Scratched Areas	10
Variable Frequency Drive Operation	10
Parts List	11
Maintenance Log	Backcover
Our Commitment	Backcover

General Information

To ensure a successful installation, the instructions in this manual should be read and adhered to. Failure to comply with proper installation procedures may void the warranty.

Unit and System Identification Tags

Each fan has a permanently affixed manufacturer's engraved metal nameplate containing the model number and individual serial number.

The tag shown is an example of an identification nameplate on the fan. The information provides general details about the fan, as well as containing specific information unique to the unit.

When contacting your local manufacturer's representative with future needs or questions, have the information on this label available. Tags are mounted in an area which is clearly visible, usually on the side of the fan housing.

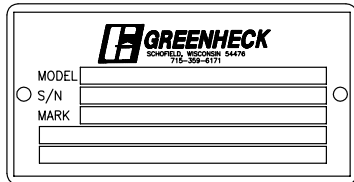

Pre-Installation Information

Before installation, it is important to be certain the mounting surface will bear the operating weight of the fan. For proper fan operation, it is also important that it be operated in a completely level position.

For further details on safety practices involving industrial and commercial fans, please refer to AMCA Publication 410.

Electrical Disconnects

All fan motors should have disconnects located in close visual proximity to turn off electrical service. Service disconnects shall be locked-out when maintenance is being performed.

Moving Parts

All moving parts must have guards to protect personnel. Refer to local codes for requirements as to the number, type and design. Fully secure fan propeller before performing any maintenance. The fan propeller may start "free wheeling" even if all electrical power has been disconnected. Before the initial start-up or any restart, check the following items to make sure that they are installed and secure.

- Do not spin fan propeller faster than the maximum cataloged fan RPM.
- Adjustments to fan speed significantly affects motor load. If the fan RPM is changed, the motor current should be checked to make sure it is not exceeding the motor nameplate amps.

Guards – Motor Cover or Inlet Guard

Do not operate fans without proper protective devices in place. Failure to do so may result in serious bodily injury and property damage. Check local codes to ensure compliance for all protective devices.

Inspection Door

Before opening the inspection door, ensure the fan propeller has stopped moving and that the propeller has been secured from being able to rotate. Do not operate fan without inspection door in its fully closed position.

Air Pressure and Suction

In addition to the usual hazards associated with rotating machinery, fans also create a dangerous suction at the inlet. Special caution needs to be used when moving around a fan, whether it is in operation or not. Before start-up, make sure the inlet area is clear of personnel and loose objects.

NOTE

For curb mounted exhaust or supply systems using "Bottom Inlet" duct connections, installation of drain locations within the ductwork is recommended to allow for safe removal of any water that enters the duct system. This requires the installing contractor to determine whether insulation, watertight construction, or sloped and drained ductwork are required. For curb mounted exhaust or supply systems with "Free Inlet Bottom Intake" connections (free air inlet conditions), it is recommended to install a moisture collecting drip pan at least one housing diameter below the inlet of the fan.

For units supplied or used with a Variable Frequency Drive (VFD), reference the VFD documentation for installation requirements, start-up settings, parameter adjustments and trouble shooting. VFDs provided by Greenheck are factory programmed for basic motor parameters, incoming voltage parameters and maximum operating speed (Hz). Follow NEC and local codes for VFD wiring and installation. If the wire length between the VFD and the controlled motor exceeds 100 ft (30.5 m), DV/DT filters or VFD cabling may be required. Calculations and proper application of DV/DT filters and VFD cabling is by others; failing to do so may result in premature motor failure.

Fans – Rigging and Lifting

IMPORTANT

Fans should never be lifted by the housing, motor, motor cover, windband or accessories.

1. Before lifting, be sure that all shipping materials have been removed from the fan.
2. Use standard lifting and rigging practices.
3. ALL lifting brackets on each fan must be utilized at the same time.
4. Fan to be kept level during lifting and installation.
5. Spreader bars are recommended and must span the fan to prevent damage to the damper section of the fan by the lifting cables.
6. Always test-lift the fan to check for proper balance and rigging before hoisting to desired location.
7. Never lift fan in windy conditions.
8. Preparation of roof opening should be completed prior to lifting fan to the roof.
9. Carefully lift the fan to the roof curb and install fasteners in all holes provided in the unit base. The windband need not be removed for the lifting operation.

Fans are to be rigged and moved by the lifting brackets shown in Figure 1 or by the skid when a forklift is used. Location of brackets varies by model and size.

Handle in such a manner as to keep from scratching or chipping the coating. Damaged finish may reduce ability of fan to resist corrosion. See coating repair section of this manual for details regarding touch-up of damaged surfaces.

Figure 1

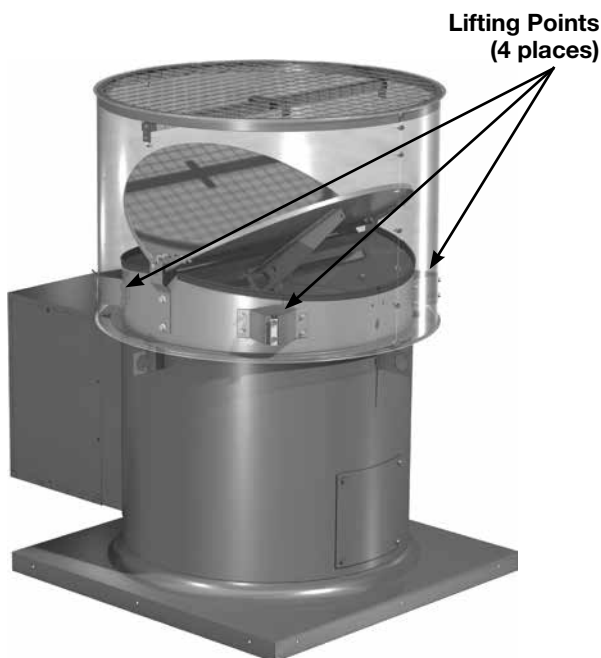

Electrical Connections

The electrical supply must be compatible with the fan motor voltage, phase and amperage capacity. The electrical supply line must be properly fused and conform to local and national electrical codes.

For belt drive units in continuous high temperature installations, the electrical supply must be kept out of the airstream. This means bringing the supply lines off the roof deck not through the fan. The electrical supply line should then be either: (1) connected to an optional service disconnect switch, or (2) wired directly to the motor.

For belt drive units in emergency smoke removal installations, the electrical supply must be kept out of the airstream. They may also require an isolated power supply so that if power is cut to the building in the event of a fire, the fan will continue to operate. Check the local and national electrical codes for emergency smoke removal fans.

 LISTED Power Ventilator For Smoke Control Systems 76Y9	–Important–
	ELECTRICAL – If fan motor is NOT thermally protected, remote overload protection must be installed having adequate rating as to voltage, frequency, horsepower, and full load current per phase. Where connected to a circuit protected by fuses, use time delay fuses. For supply connection use wires rated for at least 90°C (194°F).
	INSTALLATION – When connecting electrical power to this fan, do not restrict motor movement for possible future belt or wheel adjustment.
	CAUTION – Mount with the lowest moving part at least 8 ft (2.5m) above floor or grade level. Not required on roof mounted ventilators or duct mounted ventilators provided with belt guards.
	ATTENTION – Monter la pièce mobile la plus basse à au moins 2,5 m au-dessus du niveau du sol. Non requis pour les ventilateurs montés sur un toit ou pour les ventilateurs montés sur gaine avec protège-courroie.
	454975

Models TAUB with UL Emergency Smoke Listing will bear the label shown.

For fan sizes 42, 48, 54 and 60, see additional warnings related to the damper lifter on page 6.

Model TAUB (Sizes 42-60) UL Listed Power Ventilator for Smoke Control Systems

WARNING

Disconnect and secure to the "off" position all electrical power to the fan prior to inspection or service.

Caution must be used when working around the fusible link damper lifters. They may release the dampers unexpectedly.

All models may have fusible link damper lifters and all belt drive models with high temperature options have fusible link damper lifters under spring tension. Belt drive fans UL Listed as "Power Ventilators For Smoke Control Systems" in sizes 42, 48, 54 and 60 have extra heavy duty fusible link damper lifters under high spring tension that, for safety reasons, must be pinned to prevent accidental release. See Figure 2 below for details on how to secure the lifter arms.

Failure to comply with these safety precautions may result in serious injury or death!

WARNING

These fans have extra heavy duty fusible link damper lifters under very high spring tension that must be pinned so they cannot be accidentally tripped when servicing the fan. The fusible link damper lifters are located under the butterfly damper blades.

Figure 2A shows where the two safety pins will be located when shipped from the factory.

When maintenance is being performed on the fan, the pins **MUST** be moved from Figure 2A position to Figure 2B position. Figure 2A shows where the two safety pins are placed when the fan is in service.

Fan sizes 20, 24, 30 and 36 do not have the ability to be pinned when servicing due to differences in lifter designs.

In all cases, extreme care must be taken when working around the damper lifter assemblies or serious bodily injury or death may result.

DANGER

Débrancher et verrouiller l'alimentation électrique en position « Arrêt » avant tout contrôle ou entretien.

Faire preuve de précaution pour travailler au voisinage des lève-registres à liaison fusible. Ils peuvent libérer les registres de façon intempestive.

Les ventilateurs peuvent comporter des lève-registres à liaison fusible et tous les modèles à courroie à options haute température comportent des lève-registres à liaison fusible sous tension de ressort. Les ventilateurs à courroie homologués UL en tant que ventilateurs électriques pour systèmes d'extraction de fumée dans les tailles 42, 48, 54 et 60 comportent de robustes lève-registres à liaison fusible placés sous une forte tension de ressort qui, pour des raisons de sécurité, doivent être bloqués pour empêcher tout déclenchement accidentel. Voir comment fixer les bras de lève-registre à la Figure 2.

Toute infraction à ces mesures de précaution peut entraîner des blessures graves ou la mort.

DANGER

Ces ventilateurs comportent de robustes lève-registres à liaison fusible placés sous une très forte tension de ressort et qui doivent être bloqués pour empêcher tout déclenchement accidentel durant l'entretien du ventilateur. Les lève-registres à liaison fusible sont placés sous les clapets du registre à papillon.

La Figure 2A indique où sont placées les deux goupilles de sécurité lors de l'expédition de l'usine.

Durant les travaux d'entretien sur le ventilateur, les goupilles doivent **IMPÉRATIVEMENT** être déplacées de leur position à la Figure 2A à celle de la Figure 2B. La Figure 2A indique où les deux goupilles de sécurité doivent être placées lorsque le ventilateur est en service.

Les ventilateurs de tailles 20, 24, 30 et 36 ne peuvent pas être bloqués par une goupille durant l'entretien en raison de différences de configuration des lève-registres.

Dans tous les cas, veiller à faire preuve d'une très grande prudence pour travailler au voisinage des lève-registres, en raison du danger de blessures corporelles graves, voire de mort.

Figure 2

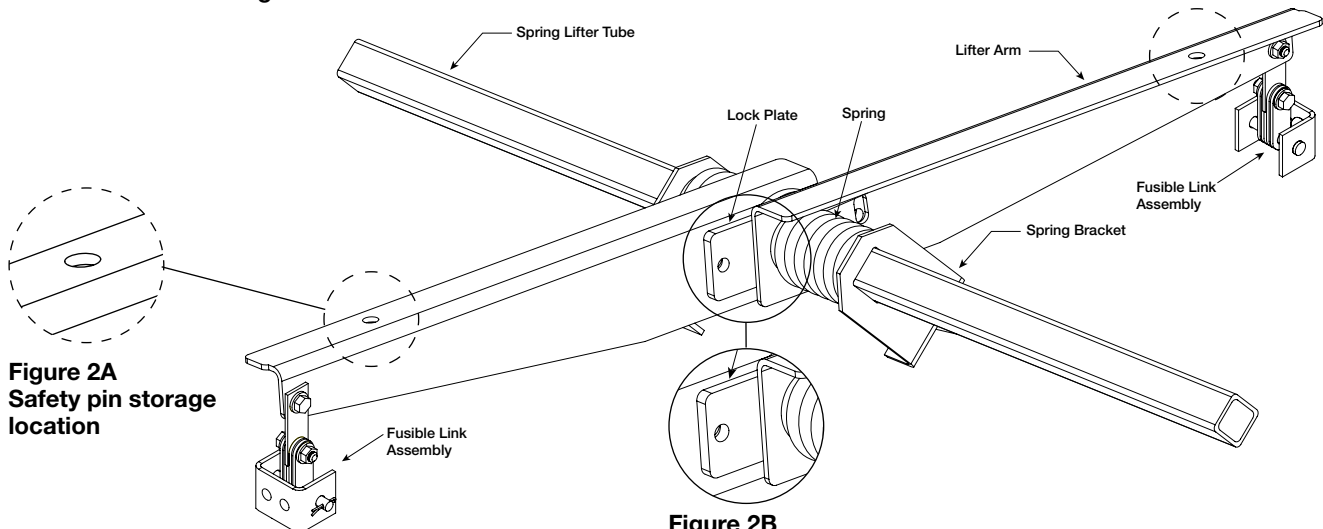

Figure 2B
Install pin here to lockout damper lifters while servicing fan

Unit Start-Up

WARNING

Disconnect and secure to the **OFF** position all electrical power to the fan prior to inspection or servicing. Failure to comply with this safety precaution could result in serious injury or death.

DANGER

Pour écarter les risques de blessure grave ou de mort, débrancher et verrouiller l'alimentation électrique en position « Arrêt » avant tout contrôle ou entretien.

Visual Inspection of Equipment

The equipment type and arrangement should be verified as ordered at once when it arrives at the jobsite. When a discrepancy is found, the local representative must be notified immediately so that corrective action may be investigated. Verify electrical conformance to specifications. Unauthorized alterations and unauthorized backcharges will not be recognized by manufacturer.

After the fan has been installed and all utilities have been hooked up, the unit is ready for operation.

Check

Before starting the fan, check the following:

1. Confirm that building supply voltage matches the voltage for which the unit is wired.
2. Check all piping and wiring penetrations made by contractors for water tightness. All penetrations must be made watertight to prevent water damage to the unit and building.
3. Rotate the fan propeller manually to be sure that it is free to operate. Remove any dirt or debris that may have accumulated during installation.
4. Check the fan bearing setscrews for tightness.
5. Check alignment of sheaves and V-belts. See Belt Drive Maintenance section.
6. Inspect all fasteners to ensure that none have loosened during shipment.
7. Check flex coupling for proper alignment and connect between motor shaft and fan shaft (direct drive).
8. Check all guarding to ensure that it is securely attached and not interfering with rotating parts.
9. Check all electrical connections for proper attachment.
10. Check housing and ductwork, if accessible, for obstructions and foreign material that may damage the fan propeller.

Additional Steps for Initial Start-Up

FASTENERS - Check all fasteners and set screws for tightness. This is especially important for bearings and propellers. Rotate the propeller by hand to assure it turns freely and does not rub on the fan tube. Also, lift the butterfly dampers to check if they open and close without binding.

PROPELLER ROTATION - Direction of propeller rotation should be checked by turning the unit on momentarily. Rotation should be in the same direction shown on the rotation

decal affixed to the unit. To reverse rotation on three phase installations, simply interchange two of the three electrical leads. For single phase installations, follow the wiring diagram located on the motor nameplate.

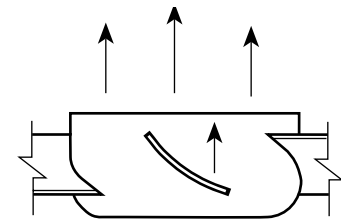

Actual direction of rotation will vary by model

FAN RPM - For belt drive units, the adjustable motor pulley is preset at the factory to the customer specified RPM. Fan speed can be increased or decreased by the adjusting the pitch diameter of the motor pulley. Multi-groove variable pitch pulleys must be adjusted an equal number of turns open. Always check the motor amperage reading and compare it to the amperage rating shown on the motor nameplate when changing fan RPM.

Electrical Connections

Before electrical connections are made, the supply voltage, phase and ampere capacity must be checked for compatibility with the fan motor. In addition, the supply wiring must be properly fused and conform to local and national electrical codes. If the unit is supplied with a safety disconnect switch, ensure proper wiring to the fan motor. Be sure the disconnect is switched to the "OFF" position before connecting supply wires. If no disconnect is supplied, ensure the supply wire is not live before connection. Supply wires are then connected to the optional safety disconnect switch (if supplied) or motor.

Routine Maintenance and Operation

WARNING

Disconnect and secure to the "OFF" position all electrical power to the fan prior to inspection or servicing. Failure to comply with this safety precaution could result in serious injury or death.

DANGER

Pour écarter les risques de blessure grave ou de mort, débrancher et verrouiller l'alimentation électrique en position « Arrêt » avant tout contrôle ou entretien.

Fan Operation

All fans should be run every thirty (30) days, or at least "bumped" every thirty days. It is preferred that each fan is run as this causes all electrical and mechanical components to get up to temperature, displacing any formed condensation, redistributes load on bearings, and redistributes grease in the motor and shaft bearings.

IMPORTANT

When operating conditions of the fan are to be changed (speed, pressure, temperature, etc.), consult manufacturer to determine if the unit can operate safely at the new condition.

Once the fan has been put into operation, periodic maintenance should be scheduled to assure reliability and performance. The following items should be checked as a part of this maintenance schedule:

Motors

Motor maintenance is generally limited to cleaning and lubrication. Cleaning should be limited to exterior surfaces only. Removing dust and grease buildup on the motor housing assists proper motor cooling. Never wash down motor with high pressure spray.

Greasing of motors is only intended when fittings are provided. Many fractional motors are permanently lubricated for life and require no further lubrication. Motors supplied with grease fittings should be greased in accordance with the manufacturer's recommendations. When motor temperature does not exceed 104°F (40°C), the grease should be replaced after 2000 hours of running time.

Direct drive systems have extended grease lines to lubricate the motor without removal of any guarding.

Fasteners and Set Screws

Normal fan vibration has a tendency to loosen mechanical fasteners. Periodic inspection should include checking all fasteners and set screws, including the propeller fasteners, for tightness.

Direct Drive Fans

LUBRICATION - Lubrication of motors is intended only when fittings are provided. Many fractional horsepower motors are permanently lubricated and require no further lubrication. Motors supplied with grease fittings should be greased in accordance with the manufacturers directions on the motor nameplate.

Belt Drive Fans

BEARINGS - Bearings are one of the most critical parts of a fan and should be inspected at regular intervals. Locking collars, set screws and fasteners attaching the bearings to the fan should also be checked.

LUBRICATION - Bearings operating in a clean environment and temperatures between 32°F and 200°F should be lubricated semiannually using a high quality lithium based grease. Those operating outside these temperatures require special high or low temperature grease. If contamination or high moisture conditions exist, more frequent lubrication is required.

Models TAUB-CA and TAUB are equipped with extended lubrication lines as standard. The grease fittings are located on the exterior of the fan housing next to the motor cover and should be wiped clean before adding grease.

When adding grease to the fan bearings, rotate the fan shaft while slowly operating the manual grease gun. **Be careful not to unseat the bearing seals by over lubricating or using excessive pressure.** Stop pumping when a very slight resistance is felt at the grease gun.

Lubrication of motors is intended only when fittings are provided. Many fractional horsepower motors are permanently lubricated for life and require no further lubrication. Motors supplied with grease fittings should be greased in accordance with the manufacturer's directions on the motor nameplate.

BELTS - V-belt drives must be checked on a regular basis for wear, tension, alignment and dirt accumulation. Premature or frequent belt failures can be caused by improper belt tension (either too loose or too tight), misaligned pulleys or by prying belts on and off pulleys. Abnormally high belt tension or drive misalignment will cause excessive bearing loads and may result in failure of the fan and/or motor bearings. Conversely, loose belts will cause squealing on start-up, excessive belt flutter, slippage and overheated sheaves. Either excessively loose or tight belts may cause fan vibration.

When replacing V-belts on multiple groove drives, all belts should be changed to provide uniform drive loading. Do not pry belts on or off the sheave. Loosen belt tension until belts can be removed by simply lifting the belts off the sheaves. After replacing belts, ensure that slack in each belt is on the same side of the drive. Belt dressing should never be used.

Do not install new belts on worn sheaves. If the sheaves have grooves worn in them, they must be replaced before new belts are installed.

The proper tension for operating a V-belt is the lowest tension at which the belts will not slip at peak load conditions. Belts are adjusted by raising or lowering the motor pivot plate. For initial tensioning, the proper belt deflection is 1/64 in. for each inch of belt span, measured half way between the pulley centers. For example, if the belt span is 64 inches, the belt deflection should be 1 inch using moderate thumb pressure at mid-point of the drive.

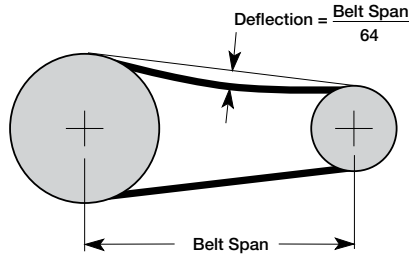

Check belt tension two times during the first 24 hours of operation and periodically thereafter.

NOTE

Model TAUB may require high temperature belts.

REMOVAL OF DUST AND DIRT - Models TAUB-CA and TAUB fans require very little attention when moving clean air. If exhausting dirty or contaminated air, the propeller and butterfly damper assembly should be cleaned periodically. Accumulations of dirt and debris on the propeller blades may cause an unbalanced condition resulting in excessive vibration and premature failure of the propeller and bearings. Excessive buildup of dirt on the damper blades may cause binding and sticking blade hinges resulting in loss of fan performance.

Periodically, the motor cover on TAUB-CA and TAUB fans should be removed and the motor cleaned of dirt and debris. Cleaning of the motor on all fans should be limited to the exterior. Removal of dust and dirt from the motor will assist in motor cooling. Motors should never be sprayed directly with water, steam or solvents.

V-Belt Replacement

The V-belt drive components, when supplied by Greenheck, have been carefully selected for this unit's specific operating condition. Changing V-belt drive components could result in unsafe operating conditions which may cause personal injury or failure of fan components.

1. Remove the protective coating from the end of the fan shaft using mineral spirits or another similar solvent. Check to ensure that the shaft is free of nicks and burrs.
2. Slide sheaves on shafts. Do not drive sheaves on as this may result in bearing damage.
3. Align fan and motor sheaves with a laser, straight-edge or string and tighten.
4. Place belts over sheaves. Do not pry or force belts, as this could result in damage to the cords in the belts.
5. Adjust the tension until the belts appear snug. Run the unit for a few minutes (refer to unit start-up section) and allow the belts to "set" properly.
6. With the fan off, adjust the belt tension by moving the adjustable motor plate. (Belts are adjusted by raising or lowering the motor plate). When in operation, the tight side of the belts should be in a straight line from sheave to sheave with a slight bow on the slack side.

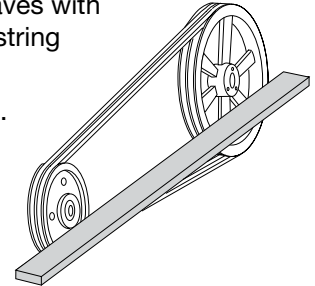

Aligning Sheaves with a Straight Edge

Alignment of Pulleys and Belts

Check pulleys and belts for proper alignment to avoid unnecessary belt wear, noise, vibration and power loss. Motor and drive shafts must be parallel and pulleys in line as shown.

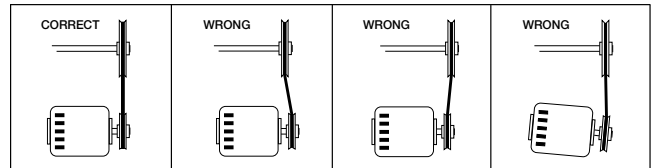

The adjustable motor pulley is set at the factory for the fan RPM specified by the customer. Fan RPM can be increased by closing or decreased by opening the adjustable motor pulley. Multi-groove variable pitch pulleys must be adjusted an equal number of turns open or closed. Any increase in fan speed represents a substantial increase in load on the motor.

To avoid motor overheating and possible burnout, motor load amperes should always be checked and compared to nameplate rating when fan speed is increased.

Field Coating Touch-Up Procedure for Scratched Areas

Standard coating and color is RAL 7023 Concrete Grey. This procedure outlines the correct method for repairing minor scratches in the coating.

TOUCH-UP PAINT REPAIR KIT CONTENTS

- One pint of Kem Kromik® primer
 - including a technical data sheet
- One pint of industrial enamel
 - including a technical data sheet
- Four disposable foam brushes
- One sheet sandpaper
- Repair procedure details

1. Scuff affected area to be repaired using medium sandpaper (provided) or medium Scotch Brite™ pad. Feather the edges.
2. Clean affected area to be touched up using an alkaline based cleaner and rinse.
3. Apply Kem Kromik® primer using 1 inch foam brush (provided). Follow technical data sheet instructions.
4. Allow primer to dry a minimum of 2-1/2 hours before top coating.
5. Apply topcoat with industrial enamel using 1 inch foam brush (provided). Follow technical data sheets instructions. Allow painted units to air-dry and cure before putting into service. See Technical Data sheets (included with kit) for detailed drying and cure schedules at different temperatures.

NOTE

While the manufacturer provides heavy-duty, quality products for marine environments, routine paint touch-ups may be required in coastal regions where salt or marine air could damage the coating. The severe environment will accelerate the damage from any scratches or chips and it is recommended that those be repaired immediately.

To order coating repair kits please reference part number HAZ2597 PNT FIELD REPAIR KIT, RAL 7023 CONCRETE GREY. Please contact factory with your fan's serial number for colors other than our standard.

Variable Frequency Drive Operation

For operation with a variable frequency drive (VFD) always check motor amps when adjusting the operating frequency. Motor may be sized for the original selected operating speed under 60 Hz. Bypassing the VFD or increasing the speed from this original selection, even if less than 60 Hz, may cause motor to overload or fail. Consult factory with fan serial number before increasing the upper limiting frequency.

Always check the fan RPM when adjusting the operating frequency. Do not exceed maximum class fan RPM of the propeller.

NOTE

It is the responsibility of the installing body to perform coast-down tests and identify any resonant frequencies after the equipment is fully installed. These resonant frequencies are to be removed from the operating range of the fan by using the "skip frequency" function in the VFD programming. Failure to remove resonant frequencies from the operating range will decrease the operating life of the fan and void the warranty.

Parts List

Each fan bears a manufacturer's nameplate with model number and serial number embossed. This information will assist the local manufacturer's representative and the factory in providing service and replacement parts. Before taking any corrective action, make certain unit is not capable of operation during repairs.

CAUTION

A fan manufactured with an explosion resistant motor does not certify the entire unit to be explosion proof. Refer to UL Listing Mark for the fans approved usage.

CAUTION

La présence d'un moteur antidéflagrant sur un ventilateur ne garantit pas que tout l'appareil est antidéflagrant. Pour connaître les emplois autorisés de l'appareil, voir son marquage de conformité UL.

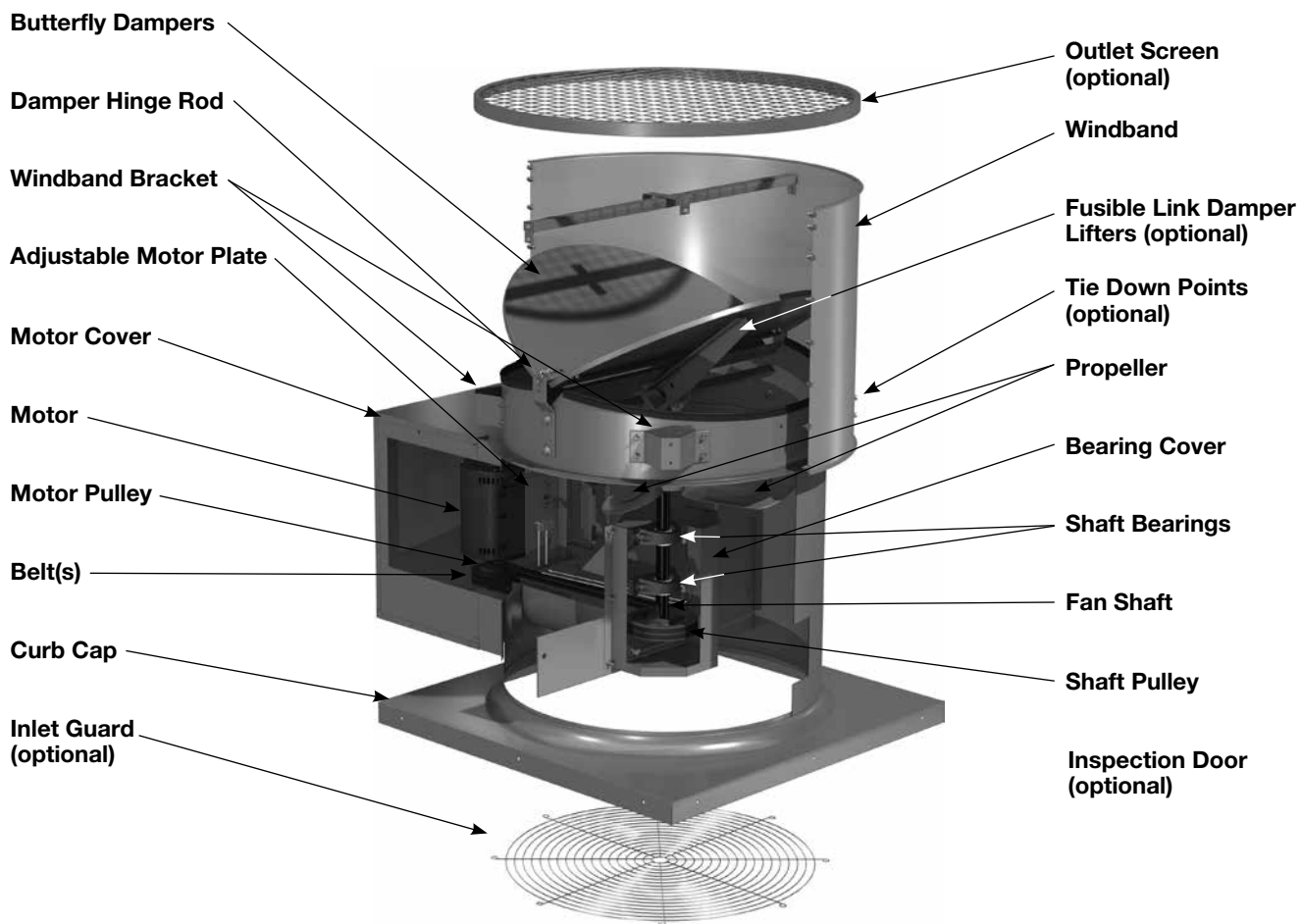

Maintenance Log

Date _____ Time _____ AM/PM
Notes: _____

Date _____ Time _____ AM/PM
Notes: _____

Date _____ Time _____ AM/PM
Notes: _____

Date _____ Time _____ AM/PM
Notes: _____

Date _____ Time _____ AM/PM
Notes: _____

Date _____ Time _____ AM/PM
Notes: _____

Date _____ Time _____ AM/PM
Notes: _____

Date _____ Time _____ AM/PM
Notes: _____

Our Commitment

As a result of our commitment to continuous improvement, Greenheck reserves the right to change specifications without notice.

Product warranties can be found online at Greenheck.com, either on the specific product page or in the literature section of the website at Greenheck.com/Resources/Library/Literature.

Greenheck Tube Axial Roof Upblast catalogs provides additional information describing the equipment, fan performance, available accessories, and specification data.

AMCA Publication 410-96, Safety Practices for Users and Installers of Industrial and Commercial Fans, provides additional safety information. This publication can be obtained from AMCA International, Inc. at www.amca.org.

