

Installation, Operation and Maintenance Manual

Please read and save these instructions. Read carefully before attempting to assemble, install, operate or maintain the product described. Protect yourself and others by observing all safety information. Failure to comply with instructions could result in personal injury and/or property damage! Retain instructions for future reference.

Model VSU



Optional Service Platform Shown

2. The rotation of the wheel is critical. It must be free to rotate without striking or rubbing any stationary objects.
3. Motor must be securely and adequately grounded.
4. Do not spin fan wheel faster than the maximum cataloged fan rpm. Adjustments to fan speed significantly affects motor load. If the fan RPM is changed, the motor current should be checked to make sure it is not exceeding the motor nameplate amps.
5. Do not allow the power cable to kink or come in contact with oil, grease, hot surfaces, or chemicals. Replace cord immediately if damaged.
6. Verify that the power source is compatible with the equipment.
7. Never open blower access doors while the fan is running.

General Safety Information

Only qualified personnel should install this unit. Personnel should have a clear understanding of these instructions and should be aware of general safety precautions. Improper installation can result in electric shock, possible injury due to coming in contact with moving parts, as well as other potential hazards. Other considerations may be required if high winds or seismic activity are present. If more information is needed, contact a licensed professional engineer before moving forward.

1. Follow all local electrical and safety codes, as well as the National Electrical Code (NEC), the National Fire Protection Agency (NFPA), where applicable. Follow the Canadian Electric Code (CEC) in Canada.

DANGER

Always disconnect power before working on or near a unit. Lock and tag the disconnect switch or breaker to prevent accidental power up.

CAUTION

When servicing the unit, motor may be hot enough to cause pain or injury. Allow motor to cool before servicing.

FOR YOUR SAFETY

If you smell gas:

1. Open windows.
2. Do not touch electrical switches.
3. Extinguish any open flame.
4. Immediately call your gas supplier.

FOR YOUR SAFETY

The use and storage of gasoline or other flammable vapors and liquids in open containers in the vicinity of this appliance is hazardous.

WARNING

Improper installation, adjustment, alteration, service or maintenance can cause property damage, injury or death. Read the installation, operating and maintenance instructions thoroughly before installing or servicing this equipment.

Receiving

Upon receiving the product check to make sure all items are accounted for by referencing the bill of lading to ensure all items were received. Inspect each crate for shipping damage before accepting delivery. Notify the carrier if any damage is noticed. The carrier will make notification on the delivery receipt acknowledging any damage to the product. All damage should be noted on all the copies of the bill of lading which is countersigned by the delivering carrier. A Carrier Inspection Report should be filled out by the carrier upon arrival and the Traffic Department. If damaged upon arrival, file claim with carrier. Any physical damage to the unit after acceptance is not the responsibility of Greenheck Fan Corporation.

Unpacking

Verify that all required parts and the correct quantity of each item have been received. If any items are missing, report shortages to your local representative to arrange for obtaining missing parts. Sometimes it is not possible that all items for the unit be shipped together due to availability of transportation and truck space. Confirmation of shipment(s) must be limited to only items on the bill of lading.

Handling

Units are to be rigged and moved by the lifting brackets provided or by the skid when a forklift is used. Location of brackets varies by model and size. Handle in such a manner as to keep from scratching or chipping the coating. Damaged finish may reduce ability of unit to resist corrosion.

Storage

Units are protected against damage during shipment. If the unit cannot be installed and operated immediately, precautions need to be taken to prevent deterioration of the unit during storage. The user assumes responsibility of the unit and accessories while in storage. The manufacturer will not be responsible for damage during storage. These suggestions are provided solely as a convenience to the user.

OUTDOOR — Units designed for outdoor applications may be stored outdoors, if absolutely necessary. Roads or aisles for portable cranes and hauling equipment are needed.

The fan should be placed on a level surface to prevent water from leaking into the unit. The unit should be elevated on an adequate number of wooden blocks so that it is above water and snow levels and has enough blocking to prevent it from settling into soft ground. Locate parts far enough apart to permit air circulation, sunlight, and space for periodic inspection. To minimize water accumulation, place all unit parts on blocking supports so that rain water will run off.

Do not cover parts with plastic film or tarps as these cause condensation of moisture from the air passing through heating and cooling cycles.

Inspection and Maintenance during Storage

While in storage, inspect fans once per month. Keep a record of inspection and maintenance performed.

If moisture or dirt accumulations are found on parts, the source should be located and eliminated. At each inspection, rotate the fan wheel by hand ten to fifteen revolutions to distribute lubricant on motor. Every three months, the fan motor should be energized. If paint deterioration begins, consideration should be given to touch-up or repainting. Fans with special coatings may require special techniques for touch-up or repair.

Machined parts coated with rust preventive should be restored to good condition promptly if signs of rust occur. Immediately remove the original rust preventive coating with petroleum solvent and clean with lint-free cloths. Polish any remaining rust from surface with crocus cloth or fine emery paper and oil. Do not destroy the continuity of the surfaces. Wipe thoroughly clean with Tectyl® 506 (Ashland Inc.) or the equivalent. For hard to reach internal surfaces or for occasional use, consider using Tectyl® 511M Rust Preventive or WD-40® or the equivalent.

REMOVING FROM STORAGE — As units are removed from storage to be installed in their final location, they should be protected and maintained in a similar fashion, until the equipment goes into operation. Prior to installing the unit and system components, inspect the unit assembly to make sure it is in working order.

1. Check all fasteners, set screws on the fan, wheel, bearings, drive, motor base, and accessories for tightness.
2. Rotate the fan wheel(s) by hand and assure no parts are rubbing.

Table of Contents

Installation
 Filter/Stand Section3-4
 Burner/Blower Section 4
 Ductwork 4
 Dimensional Data 5
 Direct Gas Piping6-7

Start-Up
 Blower8-9
 Direct Gas10-12

Operation
 Electrical 13

Troubleshooting
 Blower 14
 Heater15-17

Maintenance
 Routine18-19
 Fall 19

Reference
 Typical Control Center Layout 20
 Typical Gas Train Layout..... 20
 Start-Up Check List 21
 Maintenance Log22-23
 WarrantyBackcover

Installation

1. Filter/Stand Section

The unit should be mounted on a concrete slab four inches thick with a proper gravel drainage bed. Allow one foot on each side of the unit as shown in the Concrete Slab and Unit Footprint drawing below.

Concrete Slab Dimensions	
Housing Size	40
A	78
B	135
C	43
D	54
E	111

All dimensions are shown in inches.

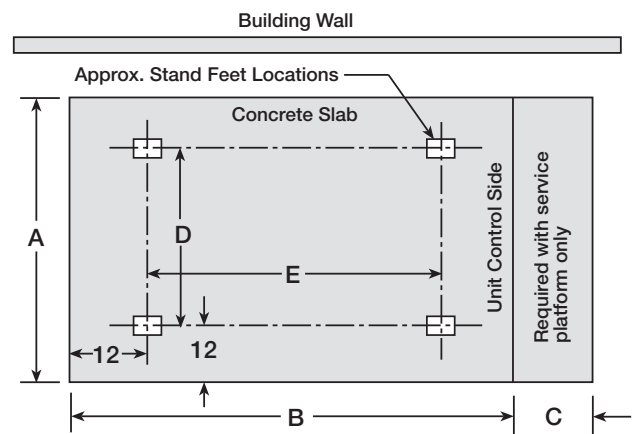

Concrete Slab and Unit Footprint

The filter section ships inside the stand (see drawing on next page). After the unit is set on the slab, it can be anchored through the stand feet. The unit footprint of the unit is shown above.

Greenheck recommends having a three foot clearance on the controls side and a two foot clearance on the other three sides of the unit for serviceability.

The following statement pertains to direct gas units only. When ordered with insulation, this unit has a zero-inch clearance tolerance to any combustibles, on all sides and top. Without insulation, the clearance tolerance is six inches.

Installation *continued*

2. Burner/Blower Section

Use a crane and a spreader bar hooked to the factory lifting lugs (shown below) to lift and center the unit onto the filter stand section. The sections can be caulked together, but it is not needed with the water kickouts provided with this section.

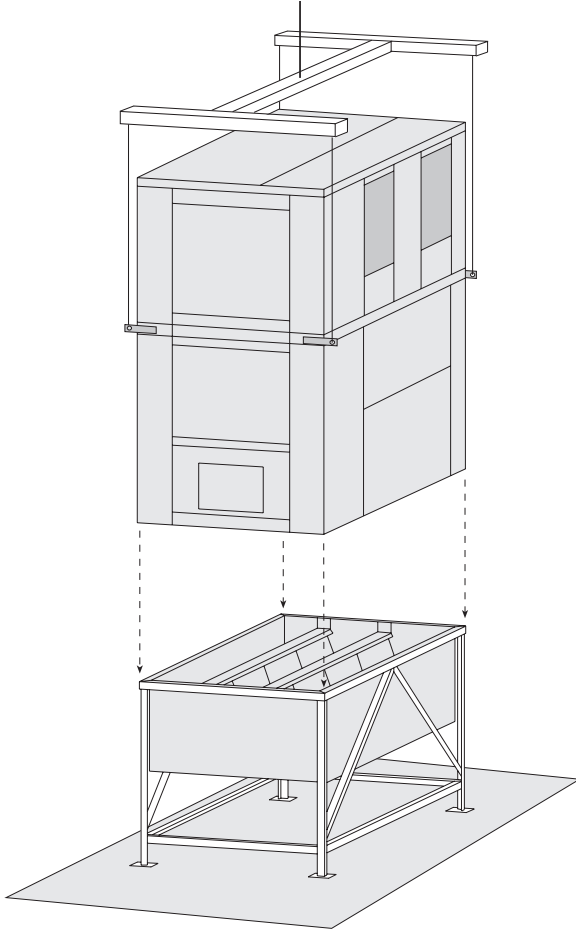

4. Complete Installation

A typical horizontal discharge installation is shown. Gas and/or electrical lines can be connected at this time.

For upblast units, a duct elbow may be needed to turn the ductwork into the building. Follow proper ductwork methods recommended by AMCA to make this elbow to minimize duct losses.

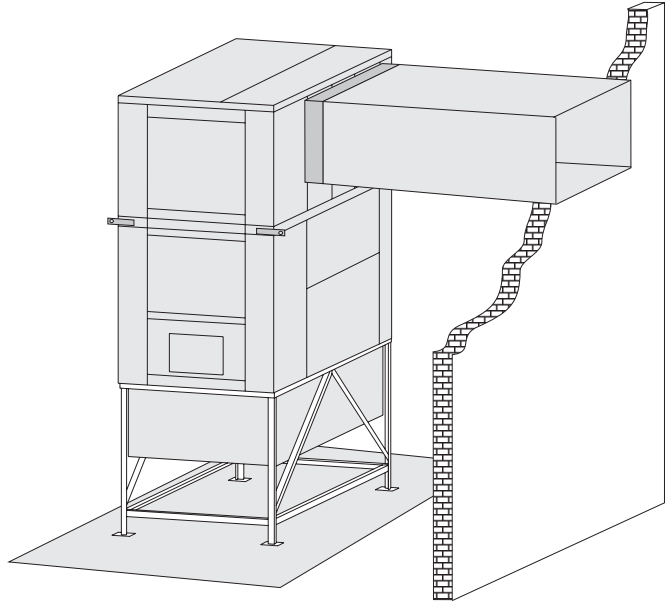

3. Install Ductwork

This table shows the duct sizes and straight lengths recommended for optimal performance (AMCA Publication 201-90). Using duct sizes less than recommended will affect fan performance. Good duct installation practices should be followed for the remaining ductwork. See the drawings in the Dimensional Data section for duct locations.

Recommended Supply Ductwork Sizes		
VSU Blower Size	Duct Size	Straight Duct Length
220	68 x 26 inches	117 inches

Dimensional Data

Upblast Discharge

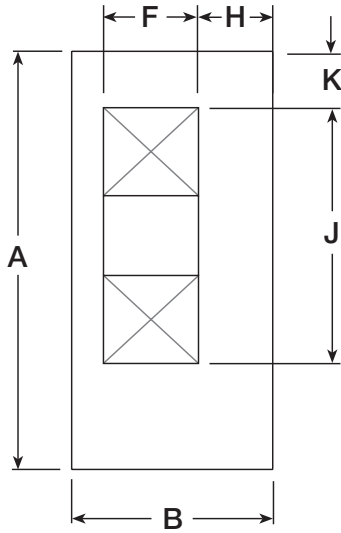

Elevation View

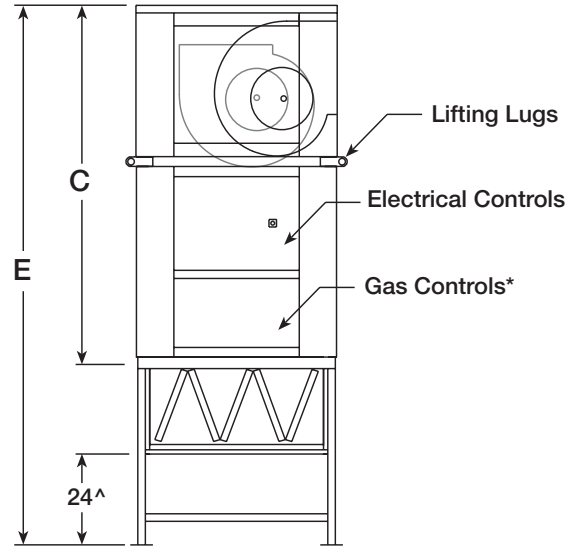

*Direct Gas units only

^Standard factory clearance. Additional stand heights are available from the factory.

Unit Dimensional Data						Blower Dimensional Data					Unit Weight	
Housing Size	A	B	C	E	Filters	Blower Size	F	H	J	K	Blower/Heater*	Stand/Filter
40	111	54	95	144	(20) 20x25	220	26	20	68	12	2000 lbs.	700 lbs.

All dimensions are shown in inches.

* Weights will vary with blower and horsepower.

Installation of Direct Gas Piping

IMPORTANT

All gas piping must be installed in accordance with the latest edition of the National Fuel Gas Code ANSI/Z223.1 and any local codes that may apply. In Canada, the equipment shall be installed in accordance with the Installation Code for Gas Burning Appliances and Equipment (CGA B149) and Provincial Regulations for the class. Authorities having jurisdiction should be consulted before installations are made.

WARNING

All components of this or any other gas-fired heating unit must be leak tested prior to placing the unit into operation. A soap and water solution should be used to perform this test. NEVER test for gas leaks with an open flame.

WARNING

If pressure testing in excess of 1/2 psig (3.5 kPa), the heater and manual shutoff valve must be disconnected from the supply gas line.

WARNING

If pressure testing at or below 1/2 psig (3.5 kPa), the heater must be isolated from the supply gas line by closing its manual shutoff valve.

IMPORTANT

All piping should be clean and free of any foreign matter. Foreign material entering the gas train can damage the valves, regulators and burner.

IMPORTANT

Do NOT connect the unit to gas types other than what is specified and do NOT connect the unit to gas pressures that are outside of the pressure range shown on the label.

NOTE

When connecting the gas supply, the length of the run must be considered in determining the pipe size to avoid excessive pressure drop. Refer to a Gas Engineer's Handbook for gas pipe capacities.

1. Determine the Supply Gas Requirements

The unit's direct gas nameplate states the requirements for the gas being supplied to the unit. The direct gas nameplate is located on the outside of the unit on the control center side.

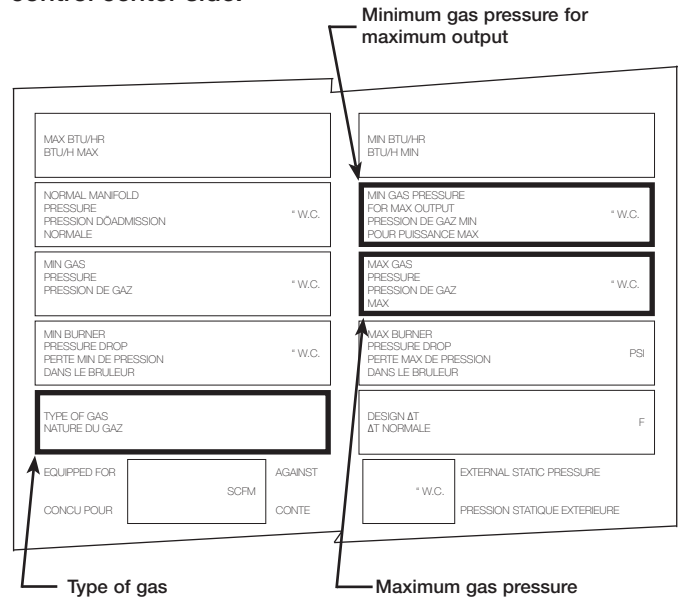

Direct Gas Nameplate

2. Install Additional Regulator if Required

When the supply gas pressure exceeds the maximum gas pressure shown on the direct gas nameplate, an additional regulator (by others) is required to reduce the pressure. The regulator must have a listed leak limiting device or it must be vented to the outdoors.

NOTE

The regulator located inside the unit is used to adjust the unit's maximum output temperature.

3. Connect the Supply Gas Line

A manual shut off valve (gas cock), 1/8 in. plugged test port and 6 in. drip leg must be installed prior to the gas train. The valve and the test port must be accessible for the connection of a test gauge. Supply gas connections must be made by a qualified installer and are not furnished by Greenheck.

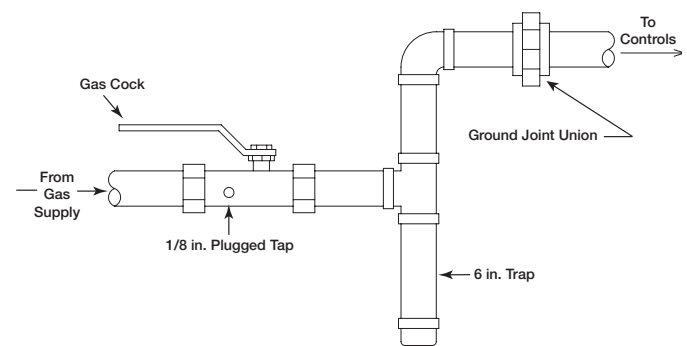

Supply Gas Line

4. Pipe the Optional Vent Line

If an optional vent line is located between the safety shutoff valves it must be piped to the outdoors.

WARNING

Reference the National Fuel Gas Code for additional vent line requirements.

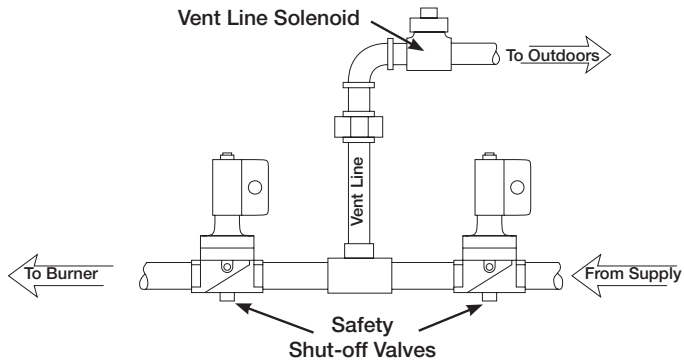

Optional Vent Line

5. Test the System for Leaks

Check both the supply lines and the factory piping for leaks. Apply a soap and water solution to all piping and watch for bubbling which indicates a leak.

WARNING

NEVER test for a gas leak with an open flame.

NOTE

The factory piping has been checked for leaks, but should be rechecked due to shipping and installation.

Start-Up - Blower

Refer to the Start-Up Checklist in the Reference section before proceeding further!

Pre Start-Up Check

Rotate the fan wheel by hand and make sure no parts are rubbing. Check the V-belt drive for proper alignment and tension (a guide for proper belt tension and alignment is provided in the Belt Maintenance section). Check fasteners, set screws and locking collars on the fan, bearings, drive, motor base, and accessories for tightness.

WARNING

Disconnect and lock-out all power and gas before performing any maintenance or service to the unit. Failure to do so could result in serious injury or death and damage to equipment.

SPECIAL EQUIPMENT REQUIRED

Required and recommended tools. Equivalent products may be used.

Voltage & Amperage Meter	Manufacturer: Fluke Model: 177 Phone: 1-800-44-FLUKE www.fluke.com
Thermometer	Manufacturer: Fluke Model: 50 Phone: 1-800-44-FLUKE www.fluke.com
Micro Amp Meter	Manufacturer: Fluke Model: 116 Phone: 1-800-44-FLUKE www.fluke.com
U-Tube Manometer	Manufacturer: Dwyer Model: Slack Tube Phone: 1-219-897-8000 www.dwyer-inst.com
Tachometer	Manufacturer: Monarch Model: Pocket Tach 100 Phone: 1-800-999-3390 www.monarchinstrument.com

WARNING

Check the housing, blower, and ductwork for any foreign objects before running the blower.

1. Check the Voltage

Before starting the unit, compare the supplied voltage, hertz, and phase with the unit and motor's nameplate information.

Voltage, Hertz, Phase

VOLTS	[]	HZ	[]	PH	[]
SUP HP	[]	EXH HP	[]		
MCA	[]	MOP	[]		

Electrical Nameplate

2. Check the Blower Rotation

Open the blower access door and run the blower momentarily to determine the rotation. Arrows are placed on the blower scroll to indicate the proper direction or reference the example shown to the right.

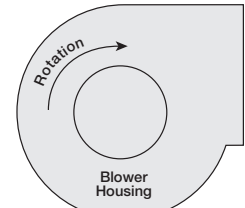

Blower Rotation

NOTE

To reverse the rotation on three phase units, disconnect and lock-out the power, then interchange any two power leads.

NOTE

To reverse the rotation on single phase units, disconnect and lock-out the power, then rewire the motor per the manufacturer's instructions.

IMPORTANT

If the blower is rotating in the wrong direction, the unit will move some air, but will not perform as designed. Be sure to perform a visual inspection to guarantee the correct blower rotation.

3. Check for Vibration

Check for unusual noise, vibration or overheating of the bearings. Reference the Troubleshooting section for corrective actions.

IMPORTANT

Excessive vibration may be experienced during the initial start-up. Left unchecked, it can cause a multitude of problems including structural and/or component failure.

IMPORTANT

Generally, fan vibration and noise is transmitted to other parts of the building by the ductwork. To minimize this undesirable effect, the use of heavy canvas duct connectors is recommended.

4. Motor Check

Measure the motor's voltage, amps and RPM. Compare to the specifications. Motor amps can be reduced by lowering the motor RPM or increasing system static pressure.

5. Air Volume Measurement & Check

Measure the unit's air volume (cfm) and compare it with its rated air volume. If the measured air volume is off, adjust the fan's RPM by changing/adjusting the drive.

NOTE

The most accurate way to measure the air volume is by using a pitot traverse method downstream of the blower. Other methods can be used, but should be proven and accurate.

IMPORTANT

Changing the air volume can significantly increase the motor's amps. If the air volume is changed, the motor's amps must be checked to prevent overloading the motor.

NOTE

To ensure accuracy, the dampers are to be open when measuring the air volume.

6. Set-up Optional Components

Adjust the settings on the optional components. See the Control Center Layout in the Reference section for location of optional components.

- Heating Inlet Air Sensor
Typical setting: 60-70°F

Start-Up Direct Gas

IMPORTANT

For proper unit function and safety, follow the start-up procedure in the exact order that it is presented.

IMPORTANT

This start-up should begin after all of the installation procedures and the blower start-up have been completed.

1. Check the Supply Gas Pressure

Check the supply gas pressure and compare it with the unit's nameplate pressure requirements. Adjust the supply regulator as needed until the supply gas pressure is within the specified range. The direct gas nameplate is located on the outside of the unit on the control center side.

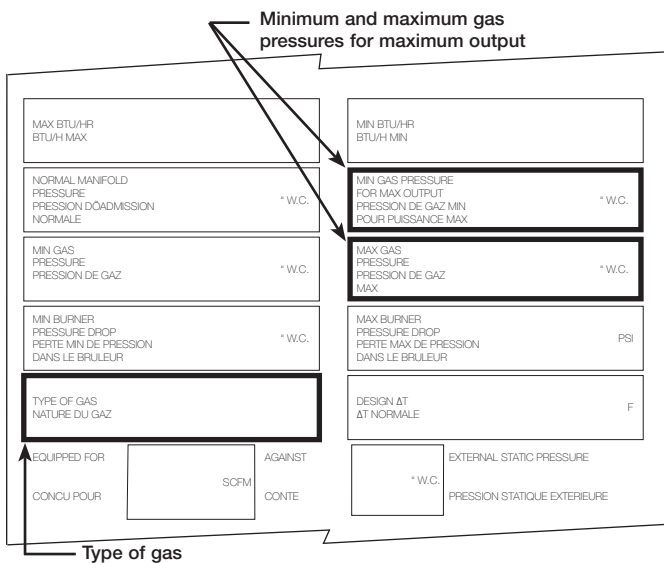

Direct Gas Nameplate

2. Check the Pilot Gas Pressure

Check the pilot gas pressure. The recommended gas pressure is 3 in. wc. Adjust the pilot regulator as needed. See the Gas Train Layout in the Reference section for the location of the pilot pressure test port and pilot regulator.

IMPORTANT

Proper air velocity over the burner is critical on direct fired gas units. If the air velocity is not within the unit specifications, the unit will not operate efficiently, may have sporadic shutdowns, and may produce excessive carbon monoxide (CO) or other gases.

3. Set the Burner Air Pressure Differential

With the fan running and discharging 70°F (21°C) air, connect a U-Tube manometer to the outer sensing probes (see below) and measure the static pressure across the burner.

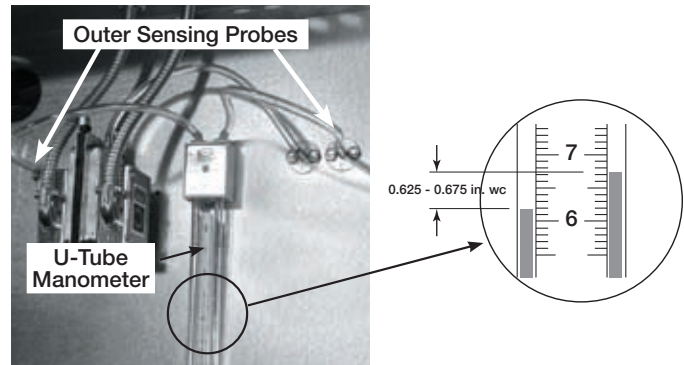

Measuring the Pressure Drop

The proper static pressure should be between 0.625 and 0.675 inches wc (155.68 and 168.64 Pa). If needed, evenly adjust the baffles on both sides of the burner, keeping the burner centered in the opening until the required pressure is obtained.

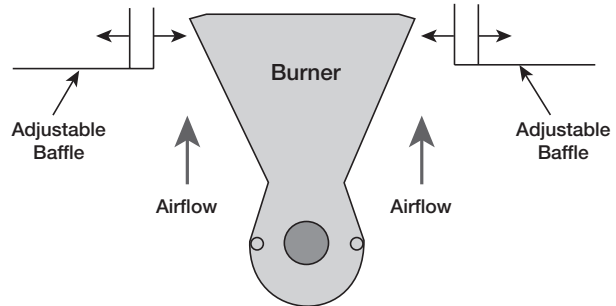

Burner and Baffles

NOTE

The pressure drop was set at the factory and may not need adjustment.

NOTE

When required pressure is obtained, be sure to reconnect the outer sensing probes.

IMPORTANT

This process may need to be repeated until the proper pressure is achieved. This adjustment will change the air quantity delivered by the unit and therefore the air quantity delivered should be rechecked. Refer to the Blower Start-Up section.

NOTE

To increase the static pressure decrease the opening. To decrease the static pressure increase the opening.

4. Set the Maximum Firing Rate

Monitor the unit's actual temperature rise by placing a thermocouple in the unit's inlet and a second in the discharge, three duct diameters downstream of the burner.

Send the unit to maximum fire by disconnecting and isolating the wire connected to Terminal 4 on the Maxitrol 14.

While monitoring the units temperature rise, set the maximum firing rate by adjusting the regulator until the designed temperature rise is achieved. After setting the maximum firing rate, reconnect the wire to the amplifier.

NOTE
Do not set the burner maximum firing rate based on gas pressure. It should be set based on the unit's designed temperature rise shown on the direct gas label.

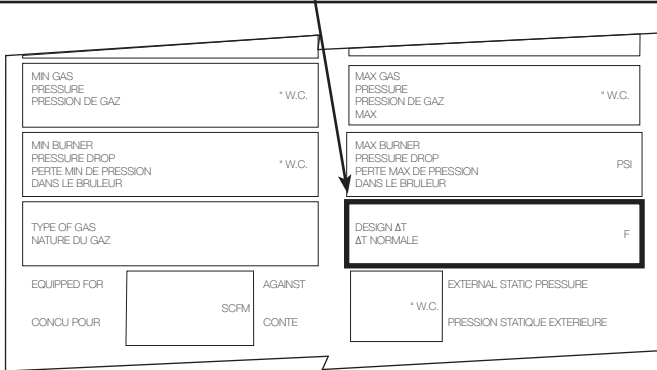

Direct Gas Nameplate

Maxitrol Series 14 — 7 terminals

Remove the wire from terminal #4 to send the unit to maximum fire

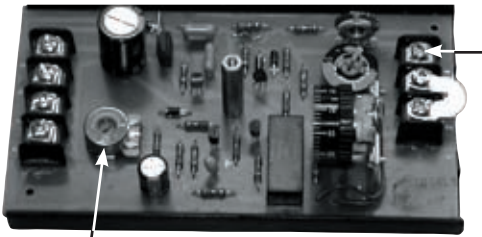

Low fire time delay setting (75% of maximum)

IMPORTANT

Setting the maximum firing rate during mild weather conditions may cause the high limit to trip out during extreme conditions requiring manual resetting.

NOTE

Gas trains are equipped with either separate regulators and modulating valves or with a combined modulating valve.

NOTE

Clockwise rotation increases the temperature rise, counterclockwise rotation decreases the temperature rise.

Regulators and Modulating Valves

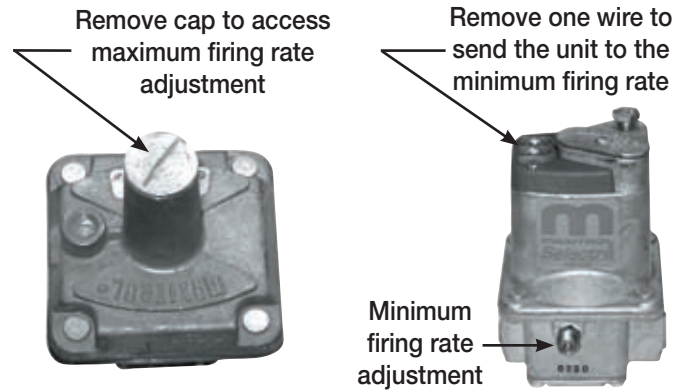

Separate Regulator and Modulating Valves

5. Set the Minimum Firing Rate

Disconnect and isolate one of the wires running to the modulating valve to send the unit to its minimum firing rate. Set the minimum firing rate by adjusting the needle valve shown above.

After setting the minimum firing rate, shut off the pilot to ensure that the flame safeguard can still read the main flame signal. Reconnect the wire to the modulation valve and open the pilot shut-off valve.

NOTE
The minimum setting for the maximum firing rate may be higher than required. This is acceptable. The burner will modulate as needed.

IMPORTANT
The proper minimum firing rate setting results in a small ribbon of continuous flame which covers the flame road and runs across the entire burner.

IMPORTANT
Do not allow the disconnected wire to come in contact with a potential ground. Damage to the amplifier or transformer could result.

NOTE
Gas trains are equipped with separate regulators and modulating valves.

NOTE
Adjusting the maximum and minimum firing rate requires the inlet air sensor to be set higher than the outdoor air temperature in order to start the burner(s). Once high and low fire have been set, the inlet air sensor should be set to the desired temperature.

NOTE
Counterclockwise rotation increases the minimum fire rate setting, clockwise rotation decreases the setting.

6. Set the Unit's Operating Temperature

Set the operating temperature. The operating temperature setting depends on which Maxitrol controller is used.

Maxitrol Series 14

The Maxitrol Series 14 should be set to the desired discharge temperature. The temperature selector is built into the amplifier.

Set the discharge temperature
Typical: 65°F

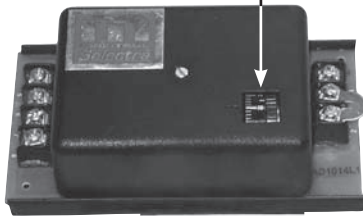

Series 14 Discharge Temperature Setting

7. Flame Signal Check

To measure the flame signal connect a standard DC voltmeter to the flame amplifier test jacks + and - (com) as shown to the right. The flame signal should be above 1.25 VDC and steady.

Check the flame signal with the burner at pilot only, minimum fire, mid fire and high fire.



**DC Voltmeter and
Flame Amplifier**

IMPORTANT

If the flame signal is not above 1.25 VDC and steady, consult the troubleshooting section.

Operation - Electrical

Electrical Sequence

1. Supply Fan Contact (S2) Closed

- Power passes to damper which opens
- When damper is fully opened, damper relay (D1) is energized an optional N.O. damper limit switch (DL1) closes
- Power passes through a N.C. fault contact on soft starter (PST(FAULT))
- Power passes to and energizes supply fan relay (RI)
- Supply fan starts

2. Heat Contact (S4) Closed

- Power passes to N.O. fan relay which is energized and closed
- Power passes to inlet air sensor contact (TS) which is energized and closed if the inlet air temperature is below the set point
- Power passes to and energizes the heat relay (RH)
- N.O. heat relay contact (RH) closes
- Power passes to and energizes terminal 5 of the Flame Safeguard (FSG).
- Power passes to N.C. high limit control contact (HLC) which is closed if temperature has remained below the high limit set point
- Power passes to terminal 6 of the Flame Safeguard (FSG)
- Flame Safeguard (FSG) begins direct gas burner sequence (see Direct Gas Burner sequence)

Direct Gas Burner Sequence

1. Supply Fan Contact Closed

- Power passes to the supply fan and heat switch

2. Heat Contact Closed

- Power passes to the heat relay then to the Flame Safeguard

3. Flame Safeguard (FSG) Sequence

- Checks for proper airflow
- Verifies no flame present at burner
- Initiates 10 second prepurge
- Sends power to open pilot gas valve (V1) and energizes the spark generator (SG) (clicking of the spark generator may be heard)
- Tries for up to 10 seconds to light pilot and confirm flame
- Powers the main gas valves open
- Shuts down spark generator
- Continuously monitors the flame and airflow
- Performs self-diagnostic check every five seconds

Troubleshooting

Blower Does Not Operate

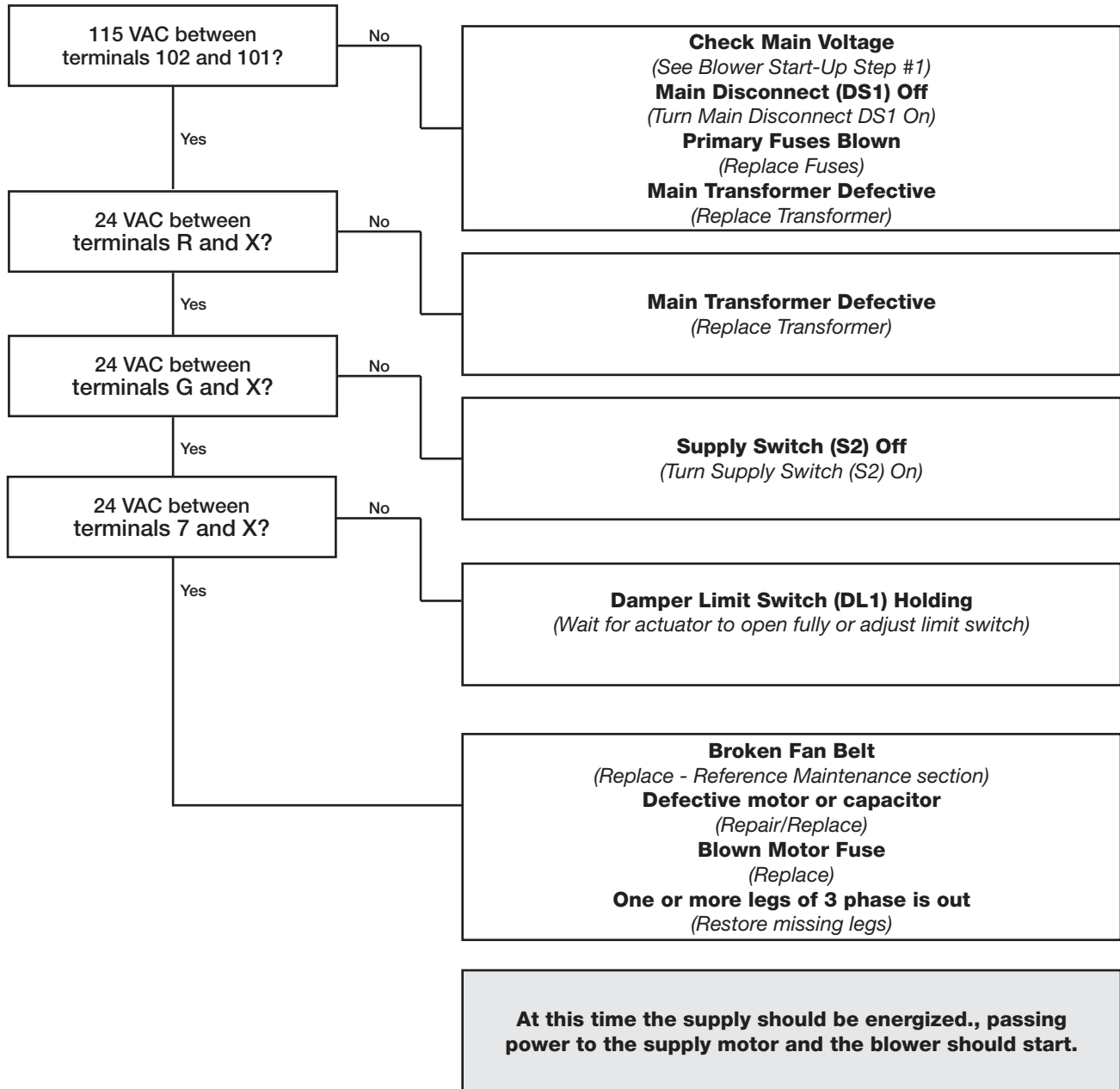

Troubleshooting

Heater Does Not Operate

Does not attempt to light (No visible spark)

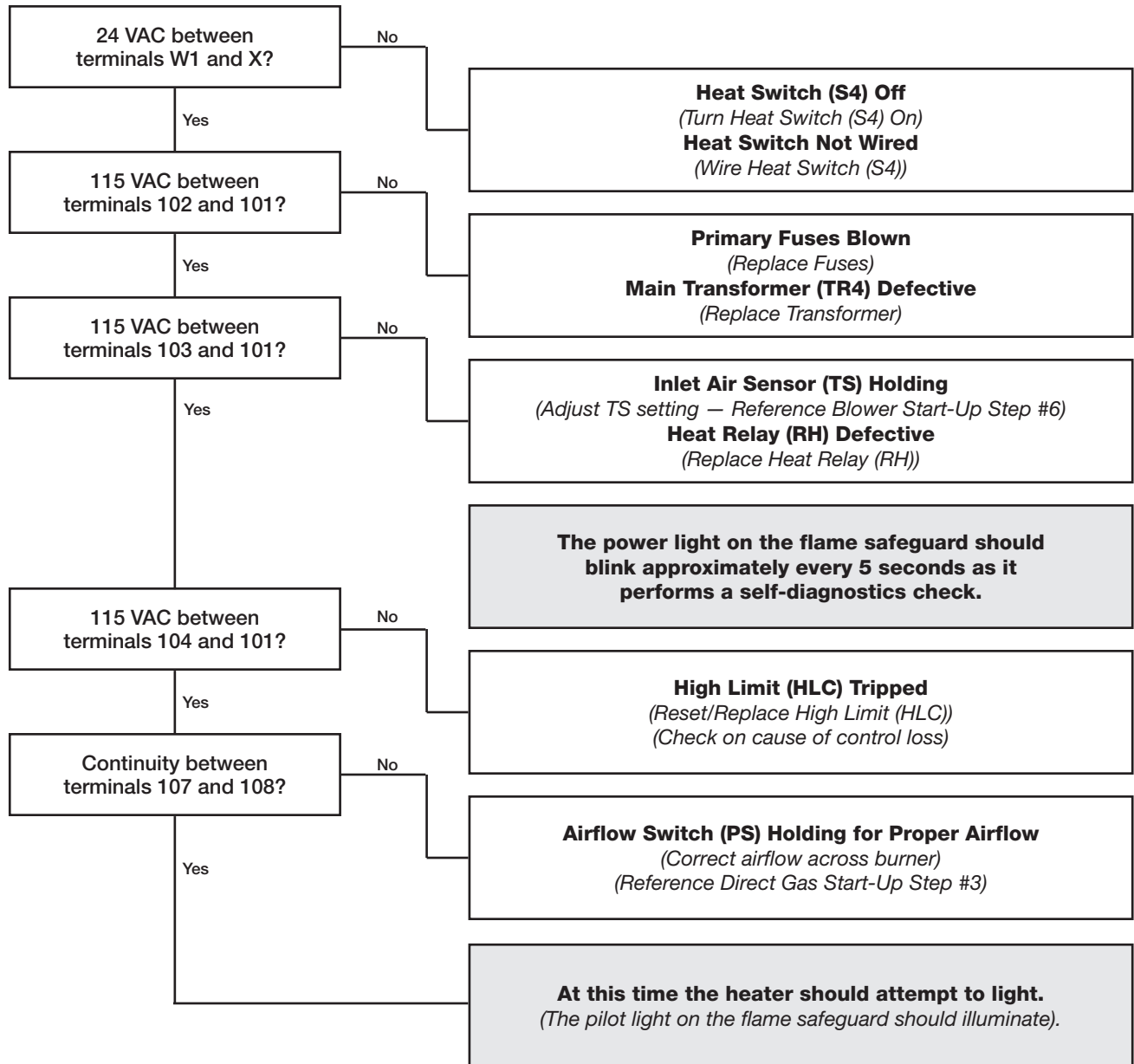

Troubleshooting

Heater Does Not Operate

Attempts to light, but no pilot (visible spark)

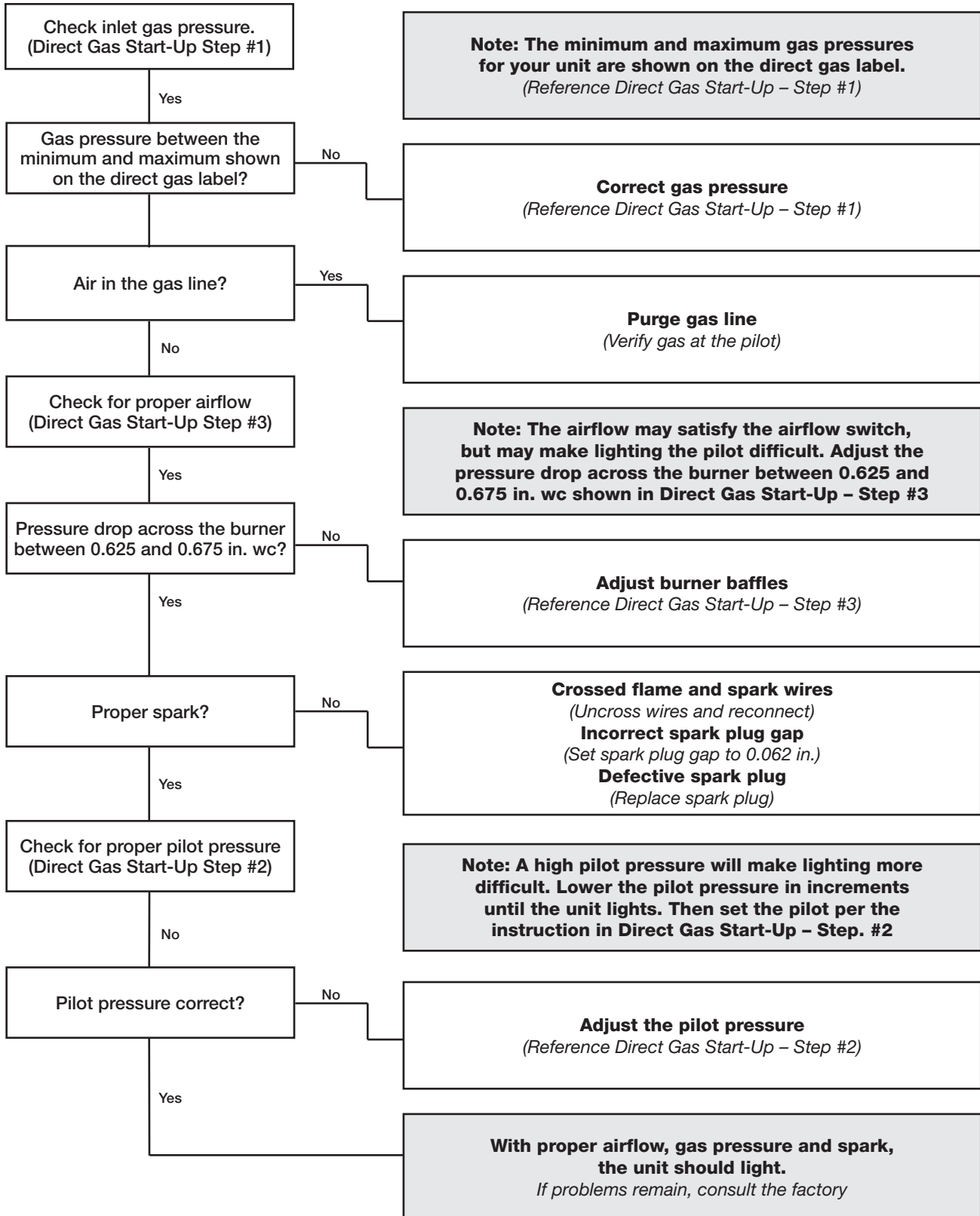

Troubleshooting

Heater Does Not Operate

Visible pilot

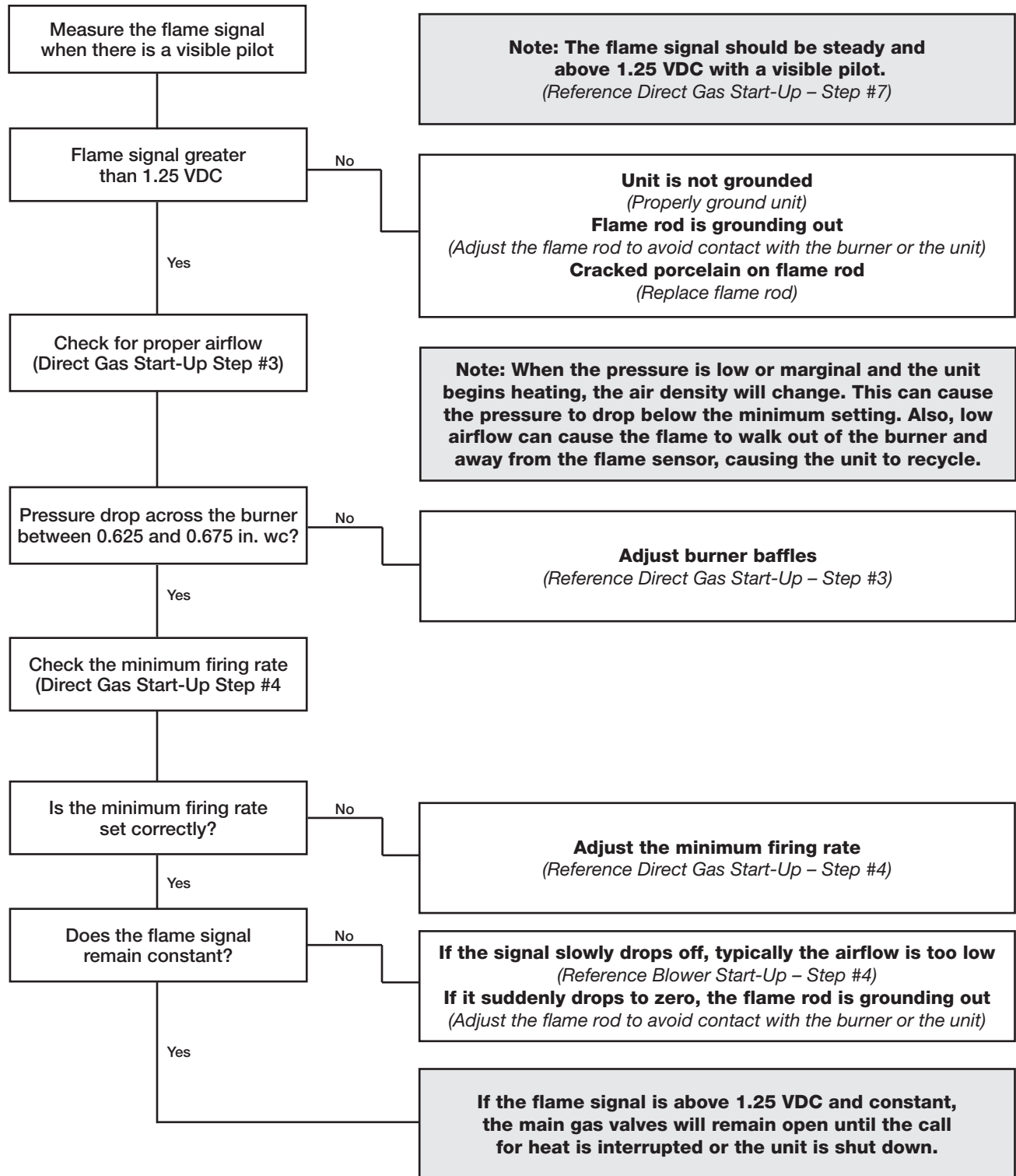

Maintenance - Routine

CAUTION

Lock-out the gas and the electrical power to the unit before performing any maintenance or service operations to this unit.

V-Belt Drives

V-belt drives must be checked on a regular basis for wear, tension, alignment, and dirt accumulation.

Check the tension by measuring the deflection in the belt as shown below.

Check the alignment by using a straight edge across both sheaves as shown below.

IMPORTANT

Premature or frequent belt failures can be caused by improper belt tension or misaligned sheaves.

- Abnormally high belt tension or drive misalignment will cause excessive bearing loads and may result in failure of the fan and/or motor bearings.
- Abnormally low belt tension will cause squealing on start-up, excessive belt flutter, slippage, and overheated sheaves.

IMPORTANT

Do not pry belts on or off the sheave. Loosen belt tension until belts can be removed by simply lifting the belts off the sheaves.

IMPORTANT

When replacing V-belts on multiple groove drives, all belts should be changed to provide uniform drive loading.

IMPORTANT

Do not install new belts on worn sheaves. If the sheaves have grooves worn in them, they must be replaced before new belts are installed.

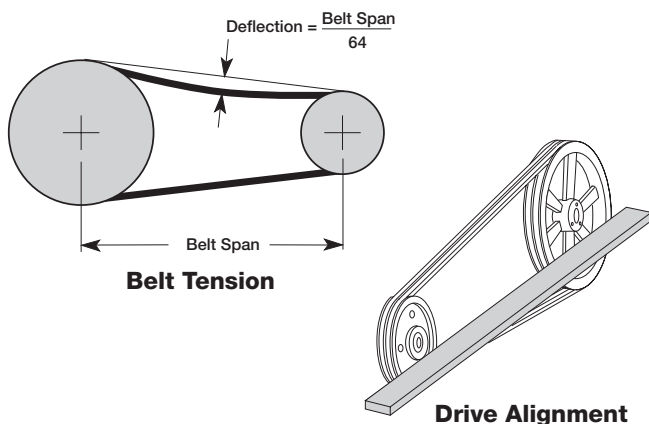

Motors

Motor maintenance is generally limited to cleaning and lubrication (where applicable).

Cleaning should be limited to exterior surfaces only. Removing dust and grease build-up on the motor assures proper motor cooling.

Motors supplied with grease fittings should be greased in accordance with the manufacturer's recommendations.

IMPORTANT

Do not allow water or solvents to enter the motor or bearings. Motors and bearings should never be sprayed with steam, water or solvents.

IMPORTANT

Greasing motors is only intended when fittings are provided. Many motors are permanently lubricated, requiring no additional lubrication.

Wheels

Wheels require little attention when moving clean air. Occasionally oil and dust may accumulate on the wheel causing imbalance. When this occurs the wheel and housing should be cleaned to assure proper operation.

Filters

Filter maintenance is generally limited to cleaning and replacement.

Aluminum mesh filters can be washed in warm soapy water.

An adhesive spray can be added to aluminum mesh filters to increase their efficiency.

IMPORTANT

When reinstalling filters, be sure to install them with the airflow in the correct direction. An airflow direction arrow is located on the side of the filters.

IMPORTANT

Replacement filters should be from the same manufacturer and the same size as the original filters provided with the unit.

Bearings

The bearings for Greenheck fans are carefully selected to match the maximum load and operating conditions of the specific class, arrangement and fan size. The instructions provided in this manual and those provided by the bearing manufacturer will minimize any bearing problems.

IMPORTANT

Lubricate bearings prior to periods of extended shutdowns or storage and rotate shaft monthly to aid in corrosion prevention. If the fan is stored more than three months, purge the bearings with new grease prior to start-up.

Recommended Bearing Lubrication Schedule (in Months*)

Fan RPM	Bearing Bore Size (inches)				
	½ - 1	1 ⅛ - 1 ½	1 ⅝ - 1 ¾	1 ¹⁵⁄₁₆ - 2 ³⁄₁₆	2 ⁷⁄₁₆ - 3
750	6	5	4	3	3

*Suggested initial greasing interval is based on 12 hour per day operation and 150°F maximum housing temperature. For continuous (24 hour) operation, decrease greasing interval by 50%

- If extended grease lines are present, relubricate while in operation, only without endangering personnel.
- For ball bearings (operating) relubricate until clean grease is seen purging at the seals. Be sure not to unseat the seal by over lubricating.
- For ball bearings (idle) add 1-2 shots of grease up to 2 inch bore size, and 4-5 shots above 2 inch bore sizes with a hand grease gun.
- For roller bearings add 4 shots of grease up to 2 inch bore size, and 8 shots for 2-5 inch bore size with a hand grease gun.
- Adjust relubrication frequency based on condition of purged grease.
- A high quality lithium based grease conforming to NLGI Grade 2 consistency, such as those listed here:

Mobil 532	Texaco Multifak #2	B Shell Alavana #2
Mobilux #2	Texaco Premium #2	Exxon Unirex #2

Maintenance - Fall

Start-Up

Repeat the Blower Start-Up Step #5 and Direct Gas Start-Up Steps #1 through #4. This will ensure that the gas and air are set properly before the heating season begins and should lead to trouble free operation all winter.

High Limit

The high limit switch may have tripped over the summer; it should be checked and reset if necessary.

Burner

Inspect the burner for accumulation of scales on both the upstream and downstream sides of the mixing plates. Any scaling or foreign material should be removed with a wire brush.

Visually check that all holes in the mixing plates are clear. If any burner ports are plugged (even partially), clear them with a piece of wire or another appropriate tool.

Replace or tighten any loose or missing fasteners on the mixing plates. Always use zinc plated or stainless steel fasteners.

Inspect and clean the flame and spark rod. Occasional replacement of the flame rod and spark rod may be necessary to ensure optimum unit performance.

WARNING

Do not enlarge burner ports when clearing a blockage, performance could be affected.

NOTE

Flame rods can last many years, but because of thermal expansion of the porcelain, flame rods can fail over time.

Reference

Typical Control Center Layout

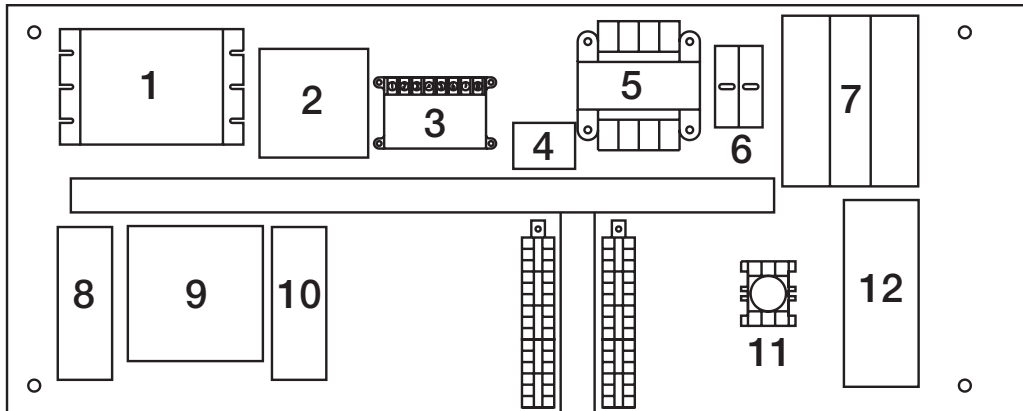

- | | |
|-------------------------|-----------------------------|
| 1. Spark Generator | 7. Motor Fuses |
| 2. Temperature Selector | 8. Heating Inlet Air Switch |
| 3. Amplifier | 9. Flame Safeguard |
| 4. 24V Transformer | 10. High Limit Switch |
| 5. 120V Transformer | 11. Disconnect |
| 6. Transformer Fuses | 12. Soft Start |

Typical Gas Train Layout

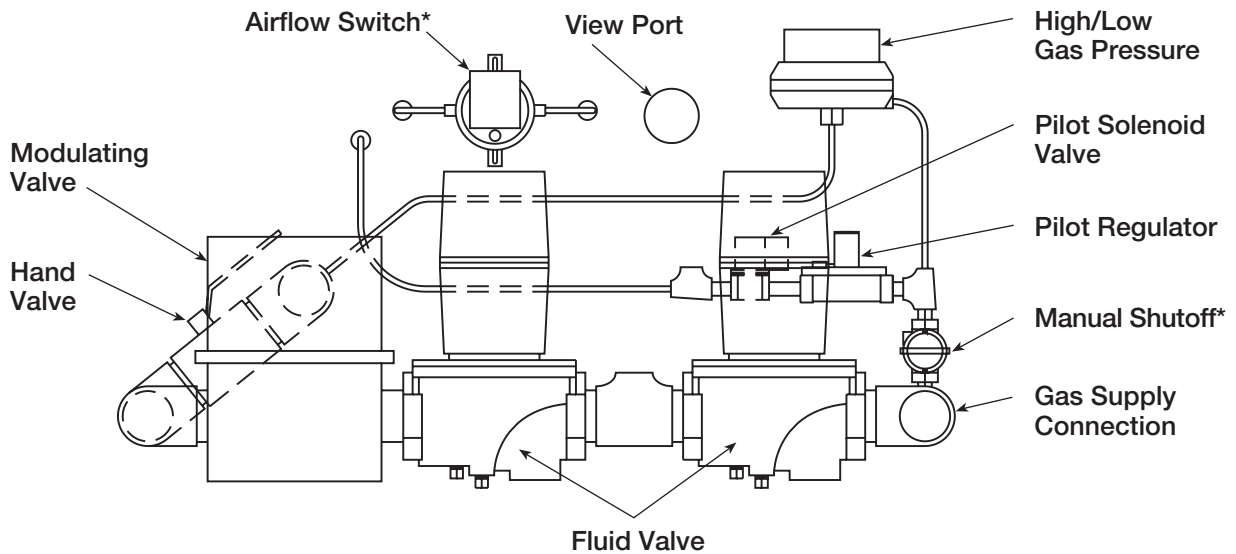

*Two are provided on Canadian units.

Maintenance Log

Date _____ Time _____ AM/PM

Notes: _____

Date _____ Time _____ AM/PM

Notes: _____

Date _____ Time _____ AM/PM

Notes: _____

Date _____ Time _____ AM/PM

Notes: _____

Date _____ Time _____ AM/PM

Notes: _____

Date _____ Time _____ AM/PM

Notes: _____

Date _____ Time _____ AM/PM

Notes: _____

Date _____ Time _____ AM/PM

Notes: _____

Date _____ Time _____ AM/PM

Notes: _____

Date _____ Time _____ AM/PM

Notes: _____

Date _____ Time _____ AM/PM

Notes: _____

Date _____ Time _____ AM/PM

Notes: _____



Maintenance Log

Date _____ Time _____ AM/PM

Notes: _____

Date _____ Time _____ AM/PM

Notes: _____

Date _____ Time _____ AM/PM

Notes: _____

Date _____ Time _____ AM/PM

Notes: _____

Date _____ Time _____ AM/PM

Notes: _____

Date _____ Time _____ AM/PM

Notes: _____

Date _____ Time _____ AM/PM

Notes: _____

Date _____ Time _____ AM/PM

Notes: _____

Date _____ Time _____ AM/PM

Notes: _____

Date _____ Time _____ AM/PM

Notes: _____

Date _____ Time _____ AM/PM

Notes: _____

Date _____ Time _____ AM/PM

Notes: _____

Warranty

Greenheck warrants this equipment to be free from defects in material and workmanship for a period of one year from the shipment date. Any units or parts which prove defective during the warranty period will be replaced at our option when returned to our factory, transportation prepaid. Motors are warranted by the motor manufacturer for a period of one year. Should motors furnished by Greenheck prove defective during this period, they should be returned to the nearest authorized motor service station. Greenheck will not be responsible for any removal or installation costs.

As a result of our commitment to continuous improvement, Greenheck reserves the right to change specifications without notice.

Greenheck's Model VSU catalog provides additional information describing the equipment, fan performance, available accessories, and specification data.

AMCA Publication 410-96, Safety Practices for Users and Installers of Industrial and Commercial Fans, provides additional safety information. This publication can be obtained from AMCA International, Inc. at: www.amca.org.



Phone: (715) 359-6171 • Fax: (715) 355-2399 • E-mail: gfcinfo@greenheck.com • Web site: www.greenheck.com