

Installing an OCI External Mount on a Damper:

1. Using a hole saw to drill a 3 $\frac{5}{8}$ in. (92 mm) diameter hole in the sleeve (**Figure 1**). See charts on page 3 for location of hole.
2. Attach indicator bracket to the blade. For an airfoil blade damper, use existing holes in blade (**Figure 2**). For a 3V blade damper, drill two 0.166 in. (4 mm) diameter holes (**Figure 3**). Fasten bracket to blade with #10 x $\frac{1}{2}$ in. (13 mm) self-drilling screws or equivalent.
3. Fit indicator link into the blade bracket (**Figure 4**).
4. Insert OCI unit through the hole in the sleeve (round end inside). See **Figure 5**.

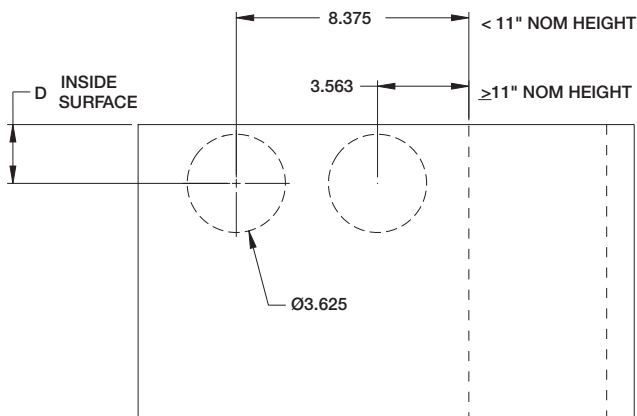

Figure 1: OCI hole location. See table on page 3 for D dimension. (All dimensions shown in inches).

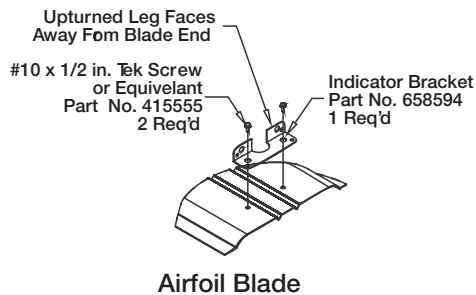
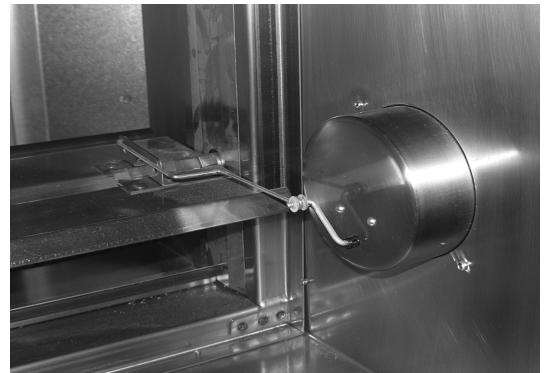

Figure 2:

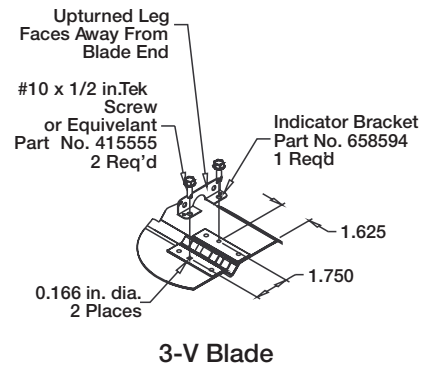
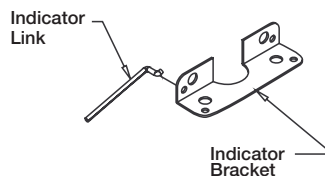

Figure 3:



Note: Indicator Link Part Nos
For Standard Sleeve (short): 457808
For Extended Sleeve (long): 457801

Figure 4

External Mount continued....

5. Place 4 in. x 4 in. (102 mm x 102 mm) J-box over the flange of the OCI unit and align holes.
6. Mount OCI/J-box assembly to the sleeve/sideplate with #10 - 16 x 3/4 in. (19 mm) self-drilling screw (or equivalent) (Figure 5).
7. Place one push nut on the switch wire. Place indicator link on switch wire and secure with a second push nut (Figure 6).
8. Complete wiring and install J-box cover (Figure 7).

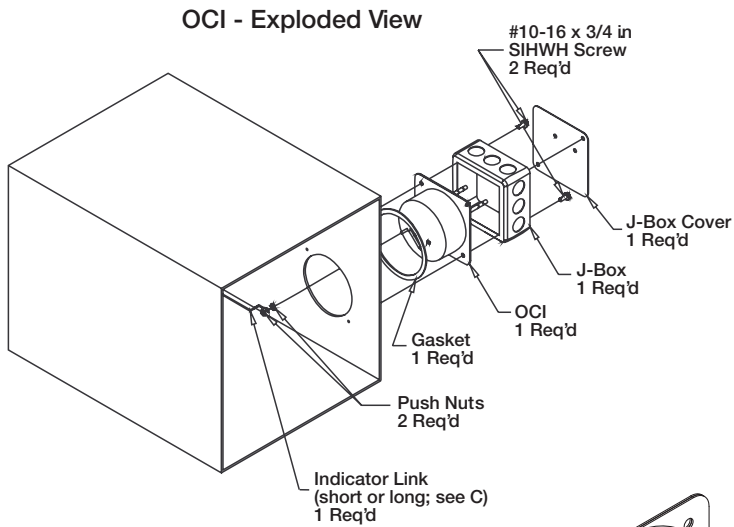

Figure 5: OCI -Exploded View

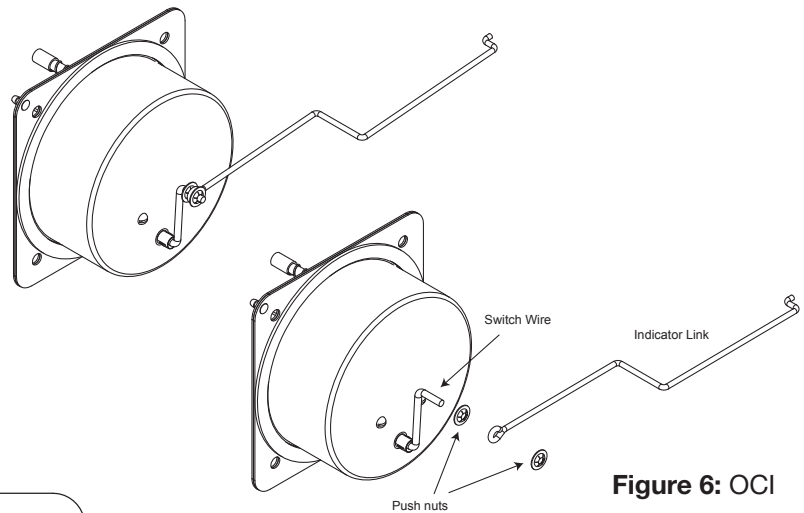

Figure 6: OCI

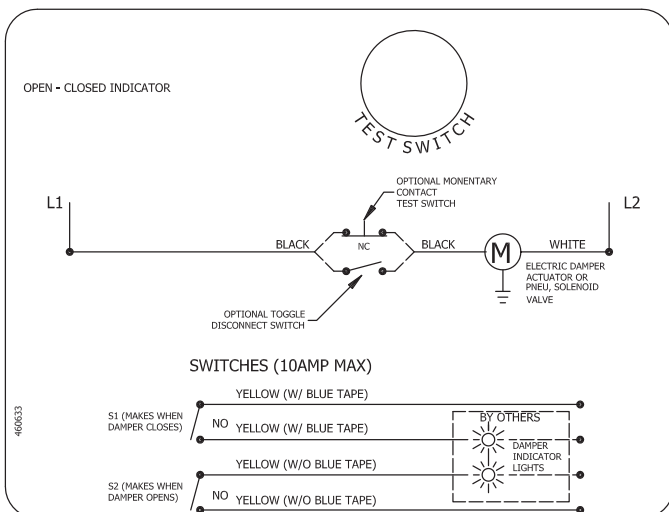

Figure 7: OCI Wiring Diagram

Mounting Hole Location

Top of Frame to Center of Hole

Nominal Section Height	FSD/SMD Series		VCD (except VCD-40)	
	In Inches	3V Style (D)	Steel Airfoil Style (D)	Parallel Blade (D)
6-7	2.625	2.625	Consult Factory	
8	3.125	3.125		
9	3.625	3.625		
10-11*	2.625	3.625		
12-13*	2.625	4.125	4.125	2.625
14-15*	3.125	4.625	4.625	3.125
16*	3.625	5.125	5.125	3.625
17*	4.125	5.625	5.625	4.125
18	13.125		14.625	
19	14.125		15.625	
20	14.625		16.125	
21	15.625		17.125	
22	16.625		18.125	
23	17.125		18.625	
24	18.125		19.625	
25	19.625		21.125	
26	20.625		22.125	
27	21.625		23.125	
28	22.125		23.625	
29	23.125		24.625	
30	24.125		25.625	
31	25.125		26.625	
32	26.625		4.625	
33	27.625		5.125	
34	28.625		5.625	
35	29.125		5.125	
36	30.625		5.625	
37	31.125		5.125	
38	32.125		5.625	
39	21.625		11.125	
40	21.625		11.125	
41	21.625		11.125	
42	22.125		11.125	
43	23.125		11.125	
44	24.125		11.625	
45	25.125		12.625	
46	28.625		18.125	

Nominal Section Height	FSD/SMD Series		VCD (except VCD-40)	
	In Inches	3V Style (D)	Steel Airfoil Style (D)	Parallel Blade (D)
47	27.625		17.125	
48	30.625		19.625	
49	29.125		17.125	
50	32.125		19.625	
51	31.125		18.625	
52	32.125		19.625	
53	23.625		25.125	
54	24.625		26.125	
55	25.125		26.625	
56	25.125		26.625	
57	23.125		24.625	
58	24.125		25.625	
59	25.125		26.625	
60	4.125		4.125	
61	-		29.125	
62	-		33.625	
63	-		30.625	
64	-		33.625	
65	-		32.625	
66	-		33.625	
67	-		35.125	
68	-		35.625	
69	-		36.625	
70	-		37.625	
71	-		38.625	
72	-		39.625	
73	-		40.625	
74	-		46.125	

***Note:** Operator mounted upside down on steel airfoil units from 10 in. to 17 in. (254 mm to 432 mm)

Installing an OCI in the Airstream (Internal Mount):

1. Attach indicator bracket to the blade. For an airfoil blade damper, use existing holes in blade (**Figure 2**). For a 3V blade damper, drill two 0.166 in. (4 mm) diameter holes (**Figure 3**). Fasten bracket to blade with #10 x ½ in. (13 mm) self-drilling screws or equivalent.
2. Fit indicator link into the blade bracket (**Figure 4**).
3. Mount opposite actuator on VCD and SMD series (control and smoke dampers). On FSD series (combination fire smoke dampers), use existing mounting bracket. Drill (2) ½ in. (7 mm) holes in the frame. Fasten the bracket (Item 11) to the frame using thread studs and nuts. Skip this step if RRL exists.
4. Assemble OCI as shown (**Figure 8**).
5. Mount bracket (Item 10) to bracket (Item 11).
6. Place one push nut on the switch wire. Place indicator link on switch wire and secure with a second push nut (**Figure 6**).
7. Complete wiring and install J-box cover.

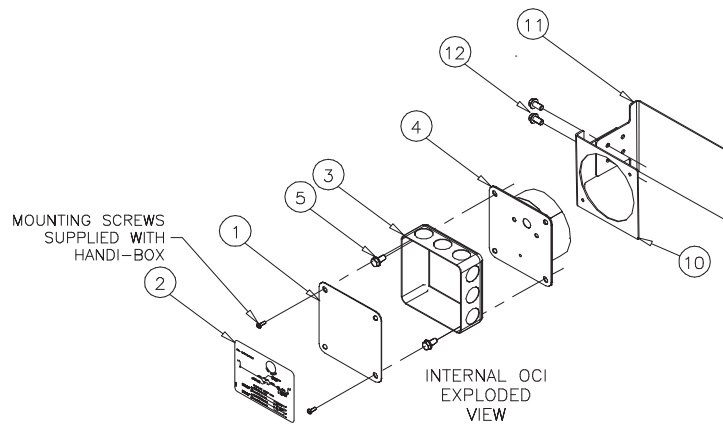
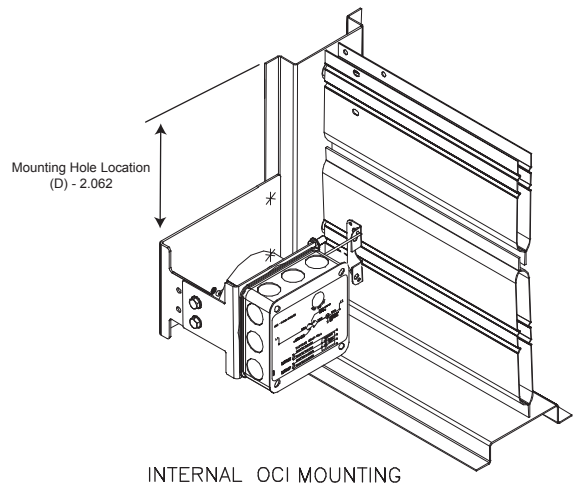

Figure 8

Item	Qty	Description
1	1	J-box cover plate w/o holes
2	1	OCI wiring label
3	1	4x4 ext box
4	1	OCI assembly
5	2	#10-16 x ¾ self drilling screw
6	1	wire
7	2	push on retainer
8	2	#10-½ self drilling screw
9	1	Indicator link blade bracket
10	1	Internal mounting bracket
11	1	Internal mounting bracket
12	2	1/4-20 x ½ screws

Our Commitment

As a result of our commitment to continuous improvement, Greenheck reserves the right to change specifications without notice.

Product warranties can be found online at Greenheck.com, either on the specific product page or in the literature section of the website at Greenheck.com/Resources/Library/Literature.

