

Exhaust Weatherhood Assembly Instructions

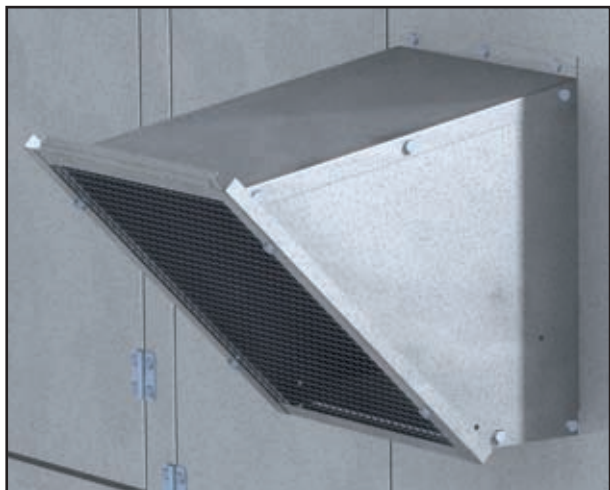

Unpack, inspect, and verify receipt of the correct weatherhood pieces for your unit. Some energy recovery units will require two exhaust weatherhoods. The exhaust weatherhood provided with your energy recovery unit is based on the exhaust blower model size.

To determine the weatherhood you have received, measure the exhaust blower scroll (see drawing below) and locate the corresponding “Blower Model” from the table.

Then refer to the Weatherhood Parts List table on the back of this document. Locate the Blower Model and compare the parts listed with the weatherhood you have received.

Once the parts are verified, continue with the weatherhood assembly procedures on Page 2.

Blower Scroll Measurements

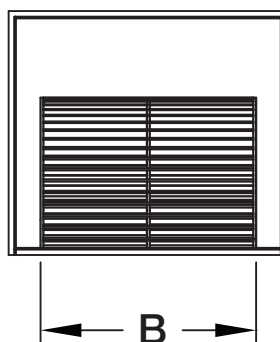
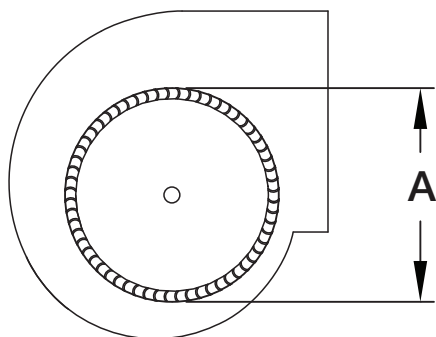

| Blower Model | A | B |
|--------------|------|------|
| A9-9A | 9.9 | 9.5 |
| A10-4A | 11.1 | 4.5 |
| A10-6A | 11.1 | 6 |
| A10-10A | 11.1 | 10.6 |
| A12-8A | 13.2 | 8 |
| A12-12A | 13.2 | 12.6 |
| A15-15A | 15.5 | 15 |
| A18-18A | 18.5 | 18 |
| A20-18A | 20.5 | 18 |

All dimensions shown in inches

| Weatherhood Parts List | | | Blower Model | | | | | | | | |
|------------------------|------------------------|-----|--------------|---------|---------|---------|---------|---------|---------|---------|---------|
| Part Description | | Qty | A10-4A | A10-6A | A9-9A | A12-8A | A10-10A | A12-12A | A15-15A | A18-18A | A20-18A |
| | | | Part #* | Part #* | Part #* | Part #* | Part #* | Part #* | Part #* | Part #* | Part #* |
| Item 1 | Weatherhood Right Side | 1 | 712526 | 712519 | 711210 | 711178 | 712519 | 711178 | 711165 | 711076 | 711221 |
| Item 2 | Damper Assembly | 1 | - | - | - | - | - | - | - | - | - |
| Item 3 | Weatherhood Top | 1 | 712525 | 712518 | 711209 | 712544 | 727644 | 711177 | 711164 | 711074 | 711217 |
| Item 4 | Weatherhood Left Side | 1 | 712527 | 712520 | 711213 | 711179 | 712520 | 711179 | 711166 | 711075 | 711220 |
| Item 5 | Weatherhood Bottom | 1 | 712528 | 712521 | 712542 | 712541 | 727646 | 712540 | 711231 | 711230 | 711232 |
| Item 6 | Cutoff | 1 | 712524 | 712517 | 711208 | 712543 | 727645 | 711176 | 711163 | 711073 | 711216 |
| Item 7 | Birdscreen Assembly | 1 | 852277 | 852275 | 852235 | 852279 | 852872 | 852233 | 852232 | 852231 | 852236 |

NOTE: Some energy recovery units require two exhaust weatherhoods.

*Part numbers are for non-painted units. Consult factory for replacement parts on painted units.

| Hardware Kit Part Number 852259 | | |
|------------------------------------|-----|--------|
| Part Description | Qty | Part # |
| Screws, SMS (A) 12 x 5/8 (IHH) | 34 | 415180 |
| Assembly Instructions | 1 | 462844 |

| Tools Required |
|--|
| <ul style="list-style-type: none"> • Cordless drill (electric or pneumatic) • 5/16 inch nut setter |

Assembly Instructions

The following steps explain how to assemble and attach the exhaust weatherhood to the energy recovery unit. Prepunched holes and sheet metal screws are provided for your convenience.

1. Attach weatherhood sides (Items 1 and 4) to energy recovery unit.
2. Attach bottom (Item 5) and cutoff (Item 6).
3. Attach damper assembly (Item 2). Damper should be sealed against cutoff.
4. Attach top (Item 3) and birdscreen (Item 7).
5. Caulk the unit/weatherhood seams on the top, bottom and sides.

After completing these steps, check to make sure the damper blade (Item 2) seals against the magnetic strips on the weatherhood sides (Items 1 and 4) and along the 45° cutoff plate (Item 5). Adjust as necessary.

Contact your local representative if replacement parts are required.

