

## Installation, Operation and Maintenance Manual

Please read and save these instructions for future reference. Read carefully before attempting to assemble, install, operate or maintain the product described. Protect yourself and others by observing all safety information. Failure to comply with these instructions will result in voiding of the product warranty and may result in personal injury and/or property damage.

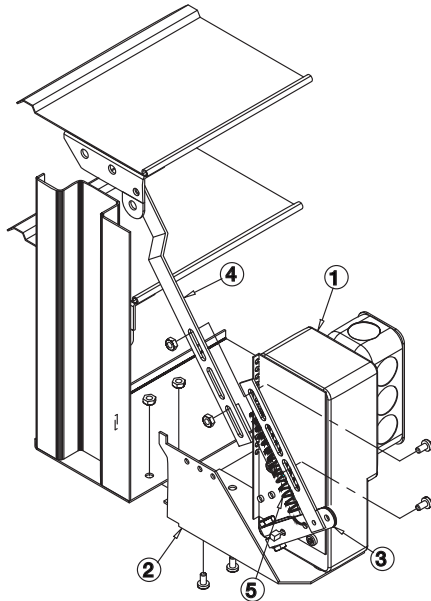

Single Panel

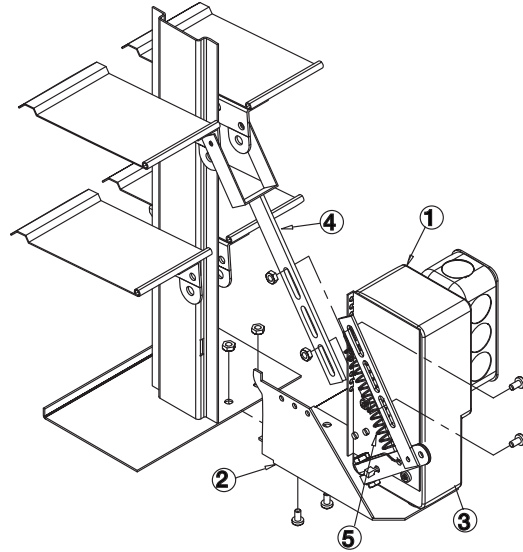

Double Panel

### Motor Pack Contents

1. Actuator
  2. Actuator Bracket
  3. Actuator Arm Assembly
  4. Connecting Links
  5. Actuator Spring
- All necessary hardware included

### Electrical Guidelines

All wiring shall be done in accordance with the National Electrical Code ANSI/NFPA-70 latest edition, any local codes that may apply, and wiring diagrams developed in compliance with the job or project design and specifications.

### Attention

Electrical input may be needed for this equipment. This work should be performed by a qualified electrician. Verify power before wiring actuator. Greenheck is not responsible for any damage to, or failure of the unit caused by incorrect field wiring. To avoid causing death or serious bodily harm to building occupants, follow all instructions carefully. Dampers must close completely to preserve the integrity of the fire smoke separation.

## Installation Instructions

1. The MP-210 motor pack is designed for installation on model WD-200 series backdraft dampers only.
2. For single panel damper, insert tab of motor bracket into the slot on the side of the frame. For dampers with center bars, the tab of the motor bracket should be inserted into the slot on the bottom of the center bearing rail. Position bracket over the two holes on the bottom of the frame and secure with the hardware provided.
3. Loosely connect the actuator arm assembly to the connecting link using the provided hardware. Fasteners should be placed as far apart as possible to provide greater stability to the linkage. The connecting links may need to be modified or shortened on some dampers sizes. To make the adjustment easier, release the spring from the spring adjustment bracket.

**Note:** The connecting link(s) have been installed on the damper at the factory.

4. To adjust the actuator linkage, position the actuator arm (attached to the damper) approximately  $\frac{1}{8}$  in. away from the rubber bumper. While holding the damper blades closed, tighten the fasteners between the connecting link and actuator arm assembly. Place the spring onto the first hook of the adjustment bracket (see **figure on page 1**). Operate the damper manually. Verify that the linkage and fasteners do not interfere with any components of the assembly and that the damper blades close completely when released. To increase spring tension, move the spring to the next hook as shown on page 1.

**Note:** It is important to avoid too much spring tension; use just enough tension to close the damper. Too much tension could impair opening of the damper or cause damage to the components as the crank arm impacts the rubber bumper.

5. Actuators are supplied with junction box and cover. When wiring, make sure the supply voltage agrees with the actuator voltage. On dual voltages motor packs, be sure to connect the proper motor leads for the correct voltage and insulate any unused wire. The voltage of each specific model is indicated on a label that is affixed to the actuator (see typical wiring diagrams).
6. Applications where airflow could be uneven, such as a discharge fan, it is imperative to verify that at no point the maximum velocity exceeds the damper cataloged velocity
7. If the damper fails to open properly, check for one of the following causes:
  - Check for an 'out of square' or racked damper
  - Check for mounting screws interfering with the blade and linkage rotation
  - Spring tension too great
  - Excessive voltage drop
  - Excessive negative pressure in the building

If actuator fails to function:

- Check for correct voltage
- Check for proper wiring

### Motor Pack Quantity

More than one motor pack may be required depending on damper size:

- On single panel dampers, the actuator is installed as shown on page 1 in the single panel view
- On double or triple panel dampers, the actuator(s) is installed as shown on page 1 in the multiple panel view.

### Actuator Specifications

MP-210 motor pack uses a single phase shaded pole stall type impedance protected electric actuators and are supplied in various voltages (see chart). For 277, 380, 575, or 600 volt operation a transformer and 120V motor pack is required.

Motor Packs	Stall Amps	Spec ID#
24V (50/60 Hz)	.66	G24
110 - 120V (50/60 Hz)	.15	G110-240
208 - 240V (50/60 Hz)	.07	G110-240
460V (60 Hz)	.041	G460

# Typical Wiring Diagrams

Wiring diagrams are shown for motor packs and dampers installed with power ventilator fan equipment with single speed motor. The damper will open when the fan is on and close when the fan is off. For connection to two-speed fan motors or for other control sequences consult the factory. The wiring diagrams shown with end switches are for applications where it is desirable to have the damper fully open before fan start-up.

## Single Phase

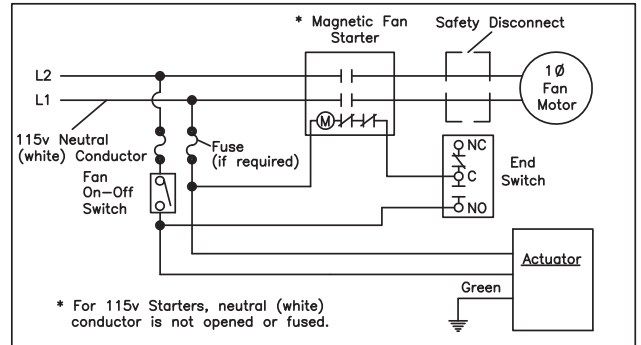
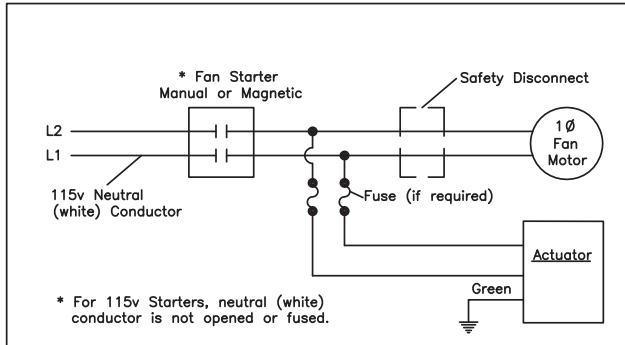

## Three Phase

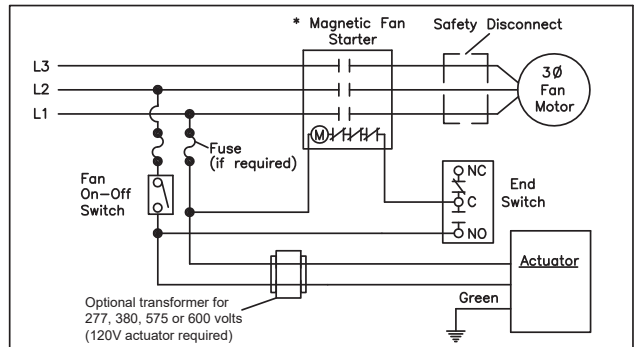
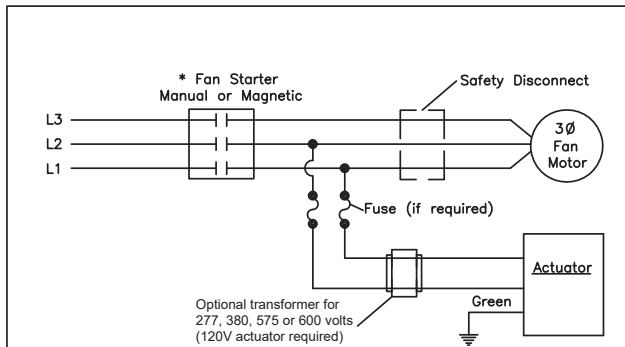

## Actuator Wiring Diagrams

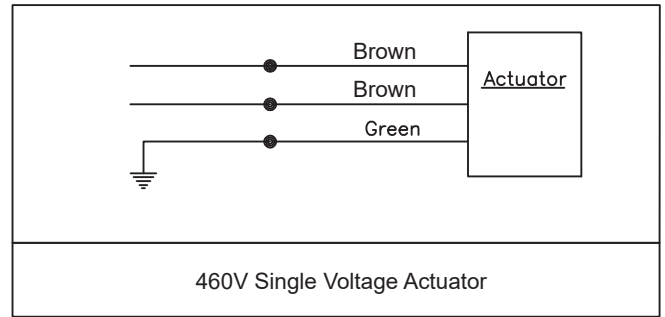
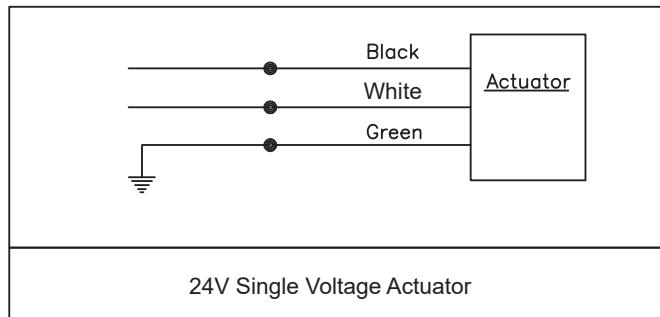
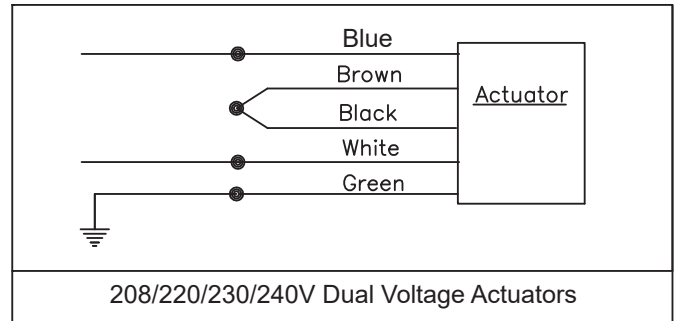
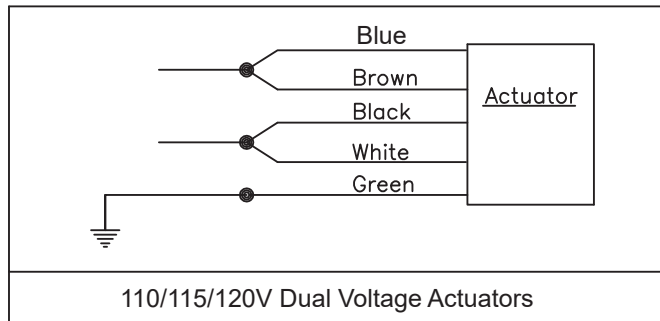

## Transformers

### 575/600 Volt Transformer Model B050WZ13

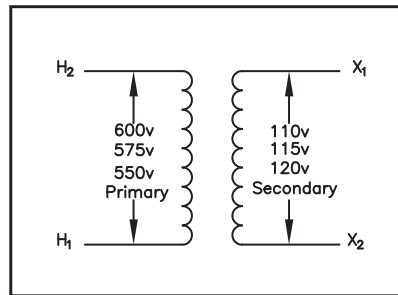

### 208/220/277/460 Volt Transformer

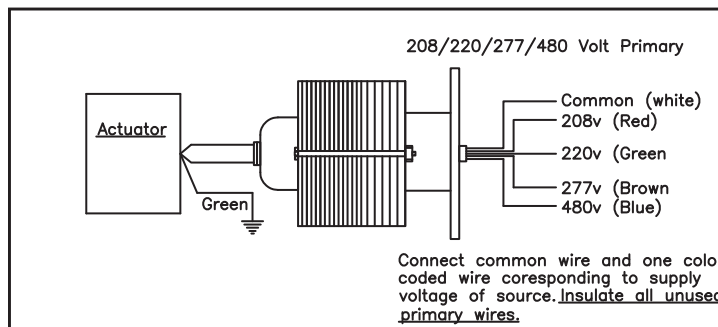

## Our Commitment

*As a result of our commitment to continuous improvement, Greenheck reserves the right to change specifications without notice.*

Product warranties can be found online at [Greenheck.com](http://Greenheck.com), either on the specific product page or in the literature section of the website at [Greenheck.com/Resources/Library/Literature](http://Greenheck.com/Resources/Library/Literature).

