

## Installation, Operation and Maintenance Manual

Please read and save these instructions for future reference. Read carefully before attempting to assemble, install, operate or maintain the product described. Protect yourself and others by observing all safety information. Failure to comply with these instructions will result in voiding of the product warranty and may result in personal injury and/or property damage.

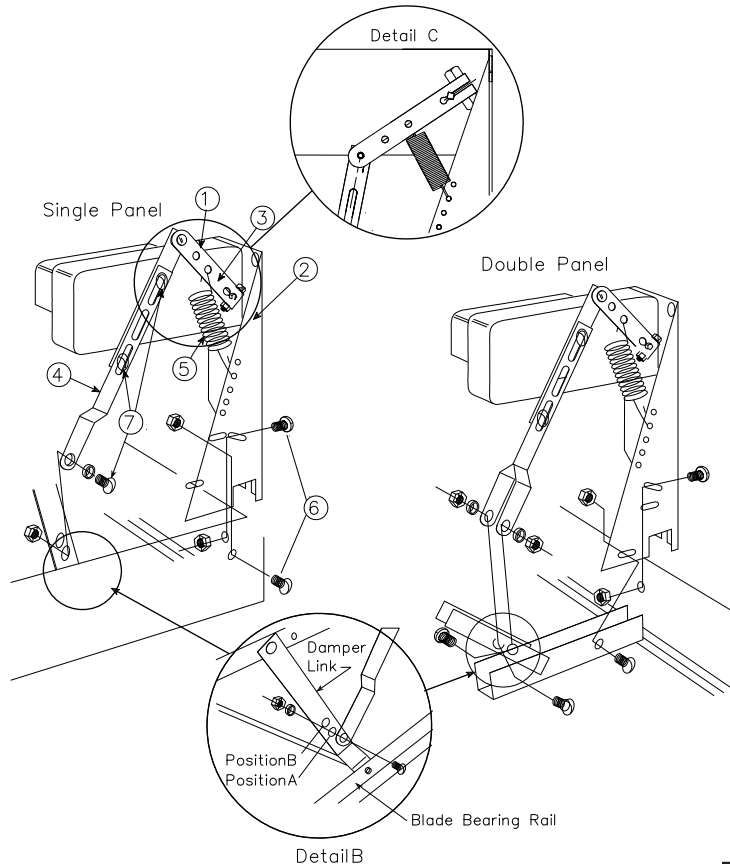

### Motor Pack Contents

1. Actuator
  2. Actuator Bracket
  3. Actuator Arm Assembly
  4. Connecting Links
  5. Actuator Spring
  6. 1/4-20 Screws and Nuts
  7. #10 Screws and Nuts
- All necessary hardware included

### Electrical Guidelines

All wiring shall be done in accordance with the National Electrical Code ANSI/NFPA-70 latest edition, any local codes that may apply, and wiring diagrams developed in compliance with the job or project design and specifications.

### Attention

Electrical input may be needed for this equipment. This work should be performed by a qualified electrician. Verify power before wiring actuator. Greenheck is not responsible for any damage to, or failure of the unit caused by incorrect field wiring. To avoid causing death or serious bodily harm to building occupants, follow all instructions carefully. Dampers must close completely to preserve the integrity of the fire smoke separation.

# Installation Instructions

1. The MP-100A motor pack is designed for installation on model WD-100 series backdraft dampers only. When properly installed, the damper will be horizontally mounted (air flow up) and the motor pack will be above the damper.
2. Attach connection link(s) to the damper link using the #10 hardware along with the bronze bushing(s), see Detail B. Use position “A” on most applications. Position “B” can be used on larger dampers when negative pressure is present. The damper blades can be lifted to the open position to provide easier access when attaching the connecting link(s) to the damper link. Tighten all fasteners.  
**Note:** Check that the connecting links are over the bushing(s) and not pinched between the end of the bushing and the screw or damper link. As the blades are being closed, the linkage bolt that is used to attach the connecting link to the damper link may interfere with damper blade bearing rail, causing the blades to remain slightly open. To resolve this interference issue, using pliers, bend that area of the damper blade bearing rail away from the bolt head until sufficient clearance is provided.
3. Attach the motor pack assembly to the damper frame with the ¼ in. #10 screws and nuts provided. Assemble the connecting link(s) to the actuator arm assembly using the hardware provided. The damper blades should be closed during this connection. The angle between the connecting links and the actuator arm should be as shown in Detail C with a slight tension on the spring. Tighten the fasteners between the connecting link and the actuator arm assembly. Fasteners should be placed as far apart as possible. This will provide greater stability to the linkage. Operate the damper manually. Verify that the linkage fasteners do not interfere with any components of the assembly and the damper blades close completely when released.  
**Note:** The spring can be adjusted to provide more or less closing force. It is important not to use too much spring tension; use just enough to help close the damper. Too much tension could impair damper opening.
4. Actuators are supplied with junction box and cover. When wiring, make sure the supply voltage agrees with the actuator voltage. On dual voltages motor packs, be sure to connect the proper motor leads for the correct voltage and insulate any unused wire. The voltage of each specific model is indicated on a label that is affixed to the actuator (see typical wiring diagrams).
5. Applications where airflow could be uneven, such as a discharge fan, it is imperative to verify that at no point the maximum velocity exceeds the damper cataloged velocity
6. If the damper fails to open properly, check for one of the following causes:
  - Check for an ‘out of square’ or racked damper
  - Check for mounting screws interfering with the blade and linkage rotation
  - Spring tension too great
  - Excessive voltage drop
  - Excessive negative pressure in the building

If actuator fails to function:

- Check for correct voltage
- Check for proper wiring

## Motor Pack Quantity

More than one motor pack may be required depending on damper size:

- On single panel dampers, the actuator is installed as shown on page 1 in the single panel view
- On double or triple panel dampers, the actuator(s) is installed as shown on page 1 in the multiple panel view.

## Actuator Specifications

MP-100A motor pack uses a single phase shaded pole stall type impedance protected electric actuators and are supplied in various voltages (see chart). For 277, 380, 575, or 600 volt operation a transformer and 120V motor pack is required.

Motor Packs	Stall Amps	Spec ID#
24V (50/60 Hz)	.66	G24
110 - 120V (50/60 Hz)	.15	G110-240
208 - 240V (50/60 Hz)	.07	G110-240
460V (60 Hz)	.041	G460

# Typical Wiring Diagrams

Wiring diagrams are shown for motor packs and dampers installed with power ventilator fan equipment with single speed motor. The damper will open when the fan is on and close when the fan is off. For connection to two-speed fan motors or for other control sequences consult the factory. The wiring diagrams shown with end switches are for applications where it is desirable to have the damper fully open before fan start-up.

## Single Phase

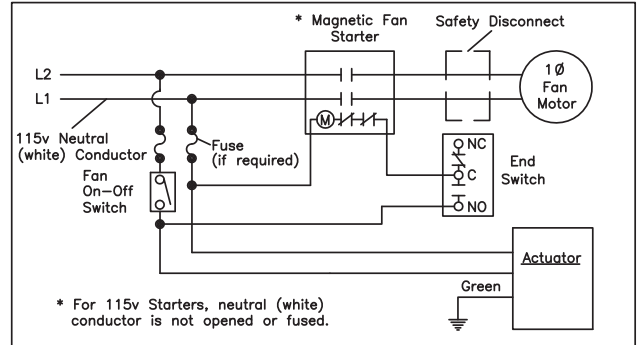
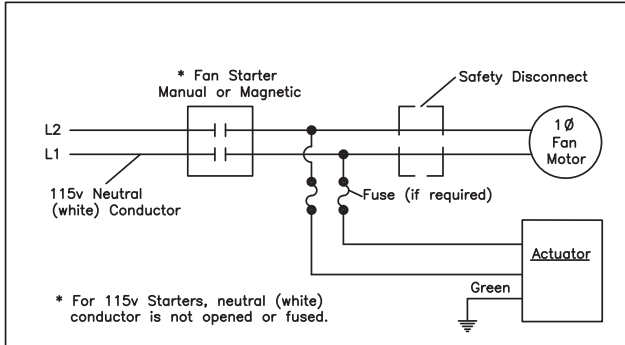

## Three Phase

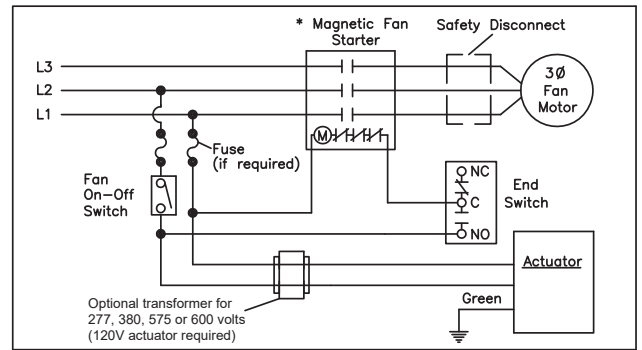
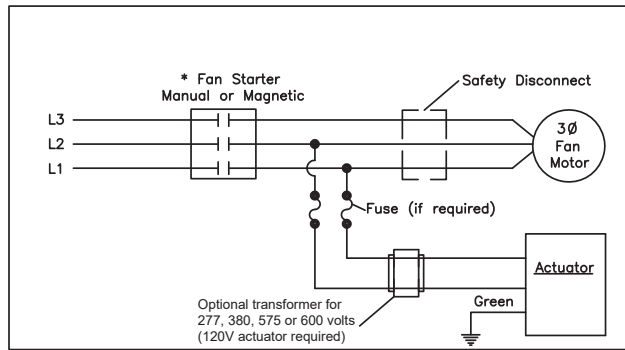

## Actuator Wiring Diagrams

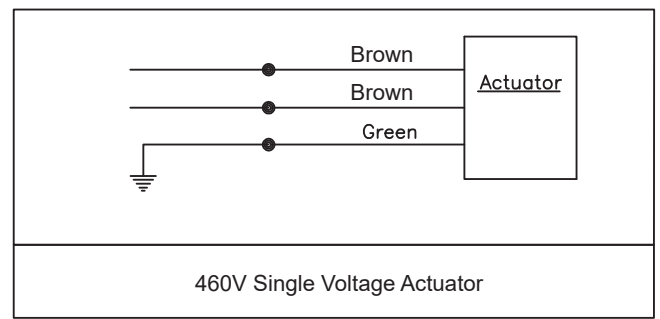
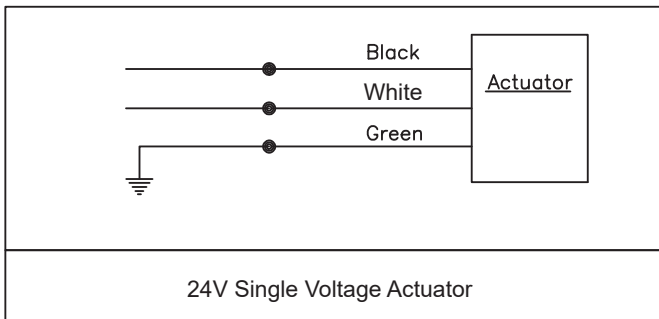
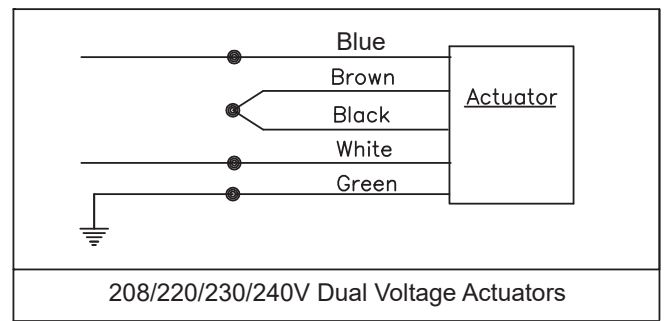
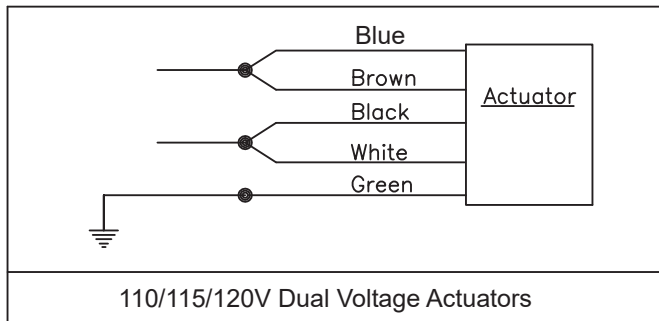

## Transformers

575/600 Volt Transformer Model B050WZ13

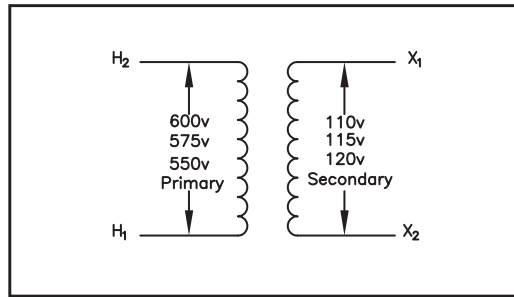

208/220/277/460 Volt Transformer

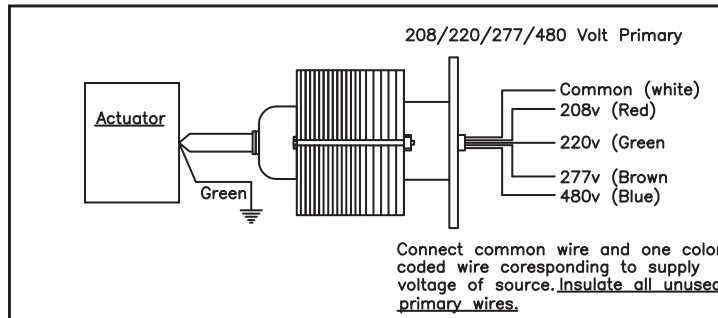

## Our Commitment

As a result of our commitment to continuous improvement, Greenheck reserves the right to change specifications without notice.

Product warranties can be found online at Greenheck.com, either on the specific product page or in the literature section of the website at Greenheck.com/Resources/Library/Literature.

