

## Installation, Operation and Maintenance Manual

Please read and save these instructions. Read carefully before attempting to assemble, install, operate or maintain the product described. Protect yourself and others by observing all safety information. Failure to comply with instructions could result in personal injury and/or property damage! Retain instructions for future reference.

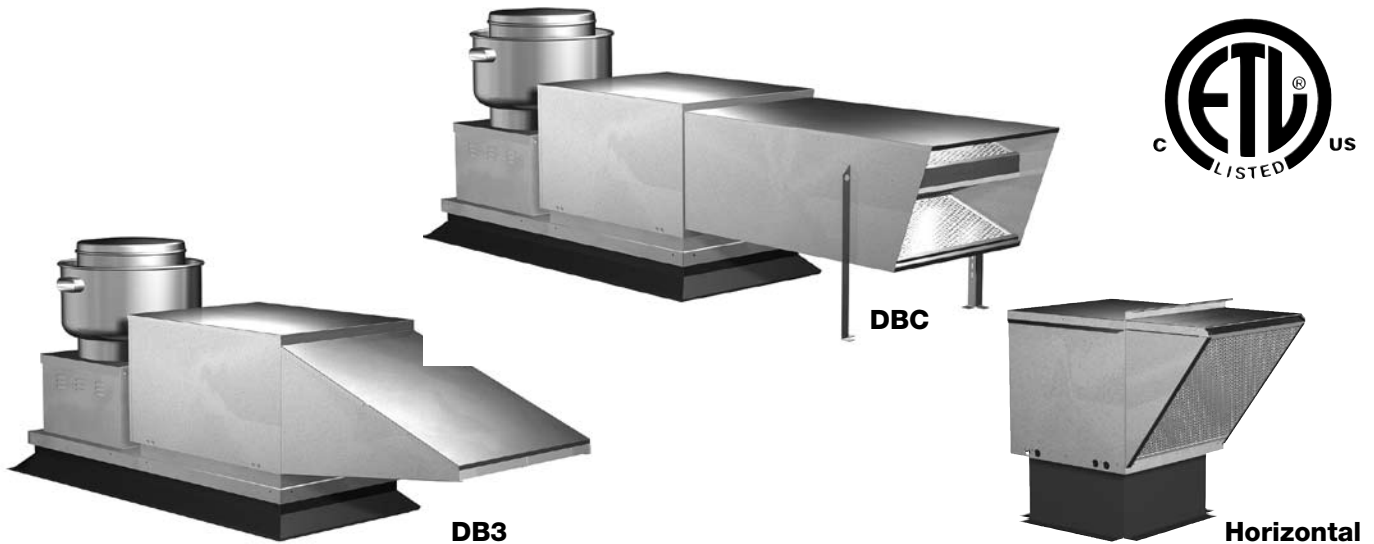

### General Safety Information

Only qualified personnel should install this unit. Personnel should have a clear understanding of these instructions and should be aware of general safety precautions. Improper installation can result in electric shock, possible injury due to coming in contact with moving parts, as well as other potential hazards. Other considerations may be required if high winds or seismic activity are present. If more information is needed, contact a licensed professional engineer before moving forward.

1. Follow all local electrical and safety codes, as well as the National Electrical Code (NEC), the National Fire Protection Agency (NFPA), where applicable. Follow the Canadian Electric Code (CEC) in Canada.

#### **DANGER**

Always disconnect power before working on or near a unit. Lock and tag the disconnect switch or breaker to prevent accidental power up.

#### **CAUTION**

When servicing the unit, motor may be hot enough to cause pain or injury. Allow motor to cool before servicing.

2. The rotation of the wheel is critical. It must be free to rotate without striking or rubbing any stationary objects.
3. Motor must be securely and adequately grounded.
4. Do not spin fan wheel faster than max cataloged fan rpm. Adjustments to fan speed significantly effects motor load. If the fan RPM is changed, the motor current should be checked to make sure it is not exceeding the motor nameplate amps.
5. Do not allow the power cable to kink or come in contact with oil, grease, hot surfaces or chemicals. Replace cord immediately if damaged.
6. Verify that the power source is compatible with the equipment.
7. Never open blower access doors while the fan is running.

#### **WARNING!**

**Improper installation, adjustment, alteration, service or maintenance can cause property damage, injury or death. Read the installation, operating and maintenance instructions thoroughly before installing or servicing this equipment.**

## Receiving

Upon receiving the product check to make sure all items are accounted for by referencing the bill of lading to ensure all items were received. Inspect each crate for shipping damage before accepting delivery. Notify the carrier if any damage is noticed. The carrier will make notification on the delivery receipt acknowledging any damage to the product. All damage should be noted on all the copies of the bill of lading which is countersigned by the delivering carrier. A Carrier Inspection Report should be filled out by the carrier upon arrival and the Traffic Department. If damaged upon arrival, file claim with carrier. Any physical damage to the unit after acceptance is not the responsibility of Greenheck Fan Corporation.

## Unpacking

Verify that all required parts and the correct quantity of each item have been received. If any items are missing report shortages to your local representative to arrange for obtaining missing parts. Sometimes it is not possible that all items for the unit be shipped together due to availability of transportation and truck space. Confirmation of shipment(s) must be limited to only items on the bill of lading.

## Handling

Units are to be rigged and moved by the lifting brackets provided or by the skid when a forklift is used. Location of brackets varies by model and size. Handle in such a manner as to keep from scratching or chipping the coating. Damaged finish may reduce ability of unit to resist corrosion.

## Storage

Units are protected against damage during shipment. If the unit cannot be installed and operated immediately, precautions need to be taken to prevent deterioration of the unit during storage. The user assumes responsibility of the unit and accessories while in storage. The manufacturer will not be responsible for damage during storage. These suggestions are provided solely as a convenience to the user.

### INDOOR

The ideal environment for the storage of units and accessories is indoors, above grade, in a low humidity atmosphere which is sealed to prevent the entry of blowing dust, rain, or snow. Temperatures should be evenly maintained between 30°F (-1°C) and 110°F (43°C) (wide temperature swings may cause condensation and “sweating” of metal parts). All accessories must be stored indoors in a clean, dry atmosphere.

Remove any accumulations of dirt, water, ice or snow and wipe dry before moving to indoor storage. To avoid “sweating” of metal parts allow cold parts to reach room temperature. To dry parts and packages use a portable electric heater to get rid of any moisture build up. Leave coverings loose to permit air circulation and to allow for periodic inspection.

The unit should be stored at least 3½ in. (89 mm) off the floor on wooden blocks covered with moisture proof paper or polyethylene sheathing. Aisles between parts and along all walls should be provided to permit air circulation and space for inspection.

### OUTDOOR

Units designed for outdoor applications may be stored outdoors, if absolutely necessary. Roads or aisles for portable cranes and hauling equipment are needed.

The fan should be placed on a level surface to prevent water from leaking into the unit. The unit should be elevated on an adequate number of wooden blocks so that it is above water and snow levels and has enough blocking to prevent it from settling into soft ground. Locate parts far enough apart to permit air circulation, sunlight, and space for periodic inspection. To minimize water accumulation, place all unit parts on blocking supports so that rain water will run off.

Do not cover parts with plastic film or tarps as these cause condensation of moisture from the air passing through heating and cooling cycles.

### Inspection and Maintenance during Storage

While in storage, inspect fans once per month. Keep a record of inspection and maintenance performed.

If moisture or dirt accumulations are found on parts, the source should be located and eliminated. At each inspection, rotate the fan wheel by hand ten to fifteen revolutions to distribute lubricant on motor. Every three months, the fan motor should be energized. If paint deterioration begins, consideration should be given to touch-up or repainting. Fans with special coatings may require special techniques for touch-up or repair.

Machined parts coated with rust preventive should be restored to good condition promptly if signs of rust occur. Immediately remove the original rust preventive coating with petroleum solvent and clean with lint-free cloths. Polish any remaining rust from surface with crocus cloth or fine emery paper and oil. Do not destroy the continuity of the surfaces. Wipe clean thoroughly with Tectyl 506 (Ashland Inc.) or the equivalent. For hard to reach internal surfaces or for occasional use, consider using Tectyl 511M Rust Preventive or WD-40 or the equivalent.

## REMOVING FROM STORAGE

As units are removed from storage to be installed in their final location, they should be protected and maintained in a similar fashion, until the equipment goes into operation.

Prior to installing the unit and system components, inspect the unit assembly to make sure it is in working order.

1. Check all fasteners, set screws on the fan, wheel, bearings, drive, motor base and accessories for tightness.
2. Rotate the fan wheel(s) by hand and assure no parts are rubbing.

## Installation

### NOTE

The use of all lifting brackets and a set of spreader bars is mandatory when lifting unit.

### STAND ALONE

1. **Install Curb:** Position curb on the roof. Refer to the CAPS submittal for curb location in relation to the unit. Verify that all unit supports are level, shim if necessary. Attach curb to roof and flash into place.

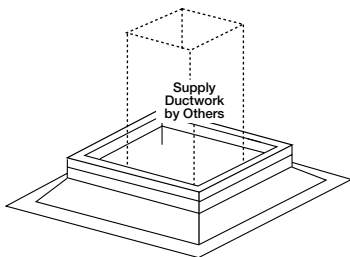

2. **Install Ductwork:** Good duct practices should be followed for all ductwork. All ductwork should be done in accordance with SMACNA and AMCA guidelines, NFPA 96 and any local codes.

See the CAPS submittal for the recommended supply duct sizes. The ductwork should extend far enough above the roofline to meet the supply unit once it is installed.

3. **Apply Sealant:** Before installing supply unit, apply a sealant around the perimeter of the supply duct to isolate the fan and minimize vibration.

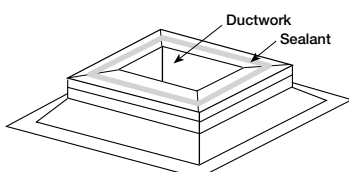

4. **Install Supply Unit:** Use a crane and a set of spreader bars hooked to the factory lifting lugs (as shown in the diagram) to lift and center the unit on the curb. Use self-tapping sheet metal screws to fasten unit to the curb.

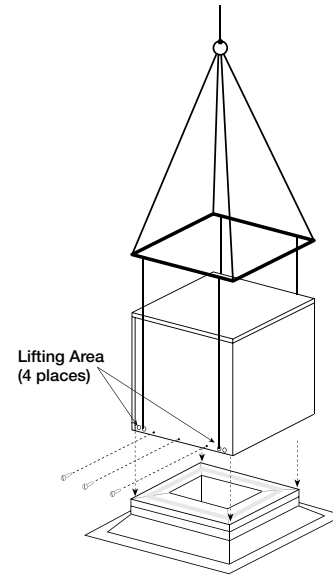

5. **Assemble Weatherhood:** See the reference section for weatherhood assembly instructions.

### Complete Installation

Illustrations show the complete installation of a standard DB and HZ and extended DB unit.

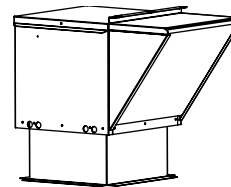

Standard Arrangement HZ

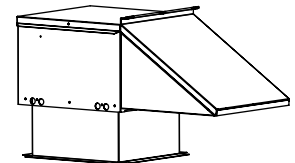

Standard Arrangement DB

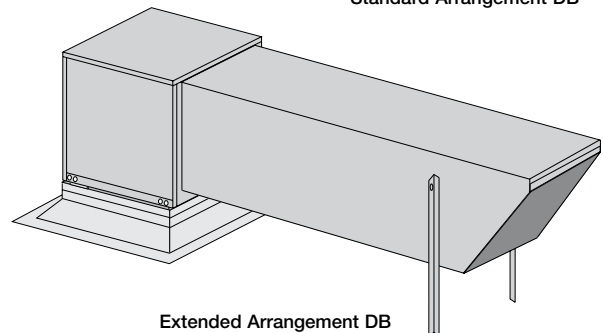

Extended Arrangement DB

## COMBO CURB

1. **Install Curb:** Position curb on the roof. Refer to the CAPS submittal for curb location in relation to the unit. Verify that all unit supports are level, shim if necessary. Attach curb to roof and flash into place.

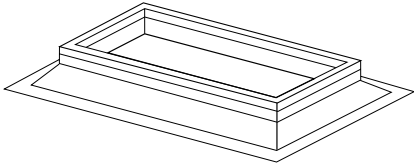

2. **Install Combination Extension:** Install combination extension over curb, use wood screws to lag in place. Locate extension so the tall louvered side is over the exhaust opening, as shown in illustration.

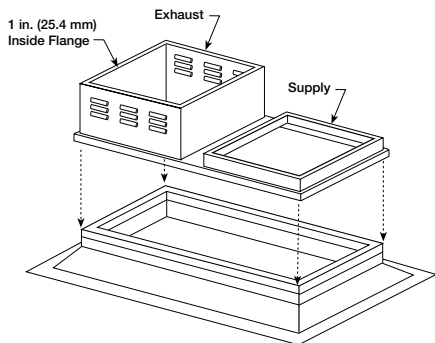

3. **Install Ductwork:** Good duct practices should be followed for all ductwork. All ductwork should be done in accordance with SMACNA and AMCA guidelines, NFPA 96 and any local codes.

See the CAPS submittal for the recommended supply and exhaust duct sizes. The ductwork should extend far enough above the roofline to meet the supply and exhaust units once they are installed.

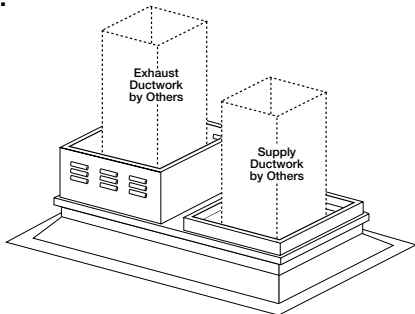

4. **Apply Sealant:** Before installing exhaust fan and supply unit, apply a sealant around the perimeter of the exhaust and supply duct to isolate the fan and minimize vibration.

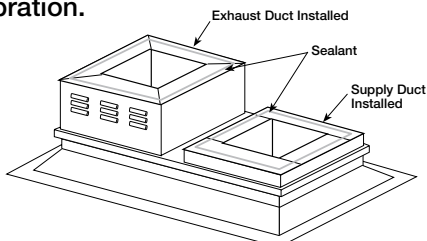

## NOTE

Installing the exhaust fan prior to the supply unit will allow for easier installation of options.

5. **Install Exhaust Fan:** Fasten exhaust fan to curb extension with self-tapping sheet metal screws.
6. **Install Exhaust Options:** Install optional hinge kit with restraining cables and grease trap with drain connection.
7. **Install Supply Unit:** Use a crane and a set of spreader bars hooked to the factory lifting lugs (as shown in the diagram) to lift and center the unit on the curb. Use self-tapping sheet metal screws to fasten unit to the curb.
8. **Assembly Weatherhood:** See the reference section for weatherhood assembly instructions.

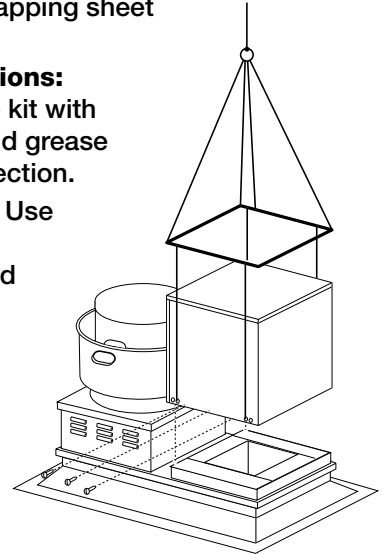

## Complete Installation

Illustrations show the complete installation of a DB3 and DBC unit.

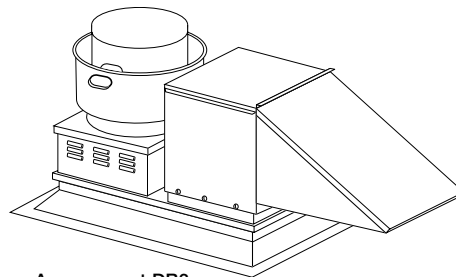

Arrangement DB3

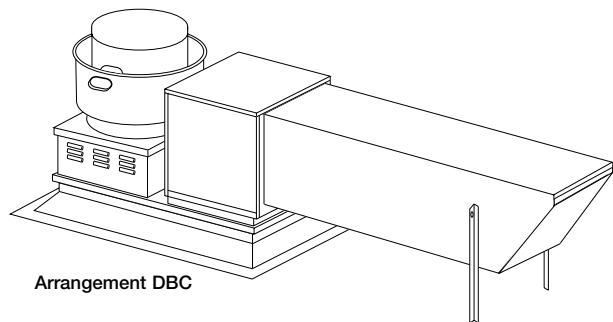

Arrangement DBC

## Electrical Wiring

### IMPORTANT

Before connecting power to the unit, understand the following instructions.

All wiring should be done in accordance with the latest edition of the National Electrical Code ANSI/NFPA 70 and any local codes that may apply. In Canada, wiring should be done in accordance with the Canadian Electrical Code.

### CAUTION

If any of the original wire must be replaced, the replacement wire must have a temperature rating of at least 105°C. Any wiring deviations may result in personal injury or property damage. Greenheck is not responsible for any damage to or failure of the unit caused by incorrect final wiring.

### DANGER

High voltage electrical input is needed for this equipment. This work should be performed by a qualified electrician.

#### 1. Determine the Size of the Main Power Lines:

The unit nameplate states the unit's voltage and total amps. The main power lines to the unit should be sized accordingly.

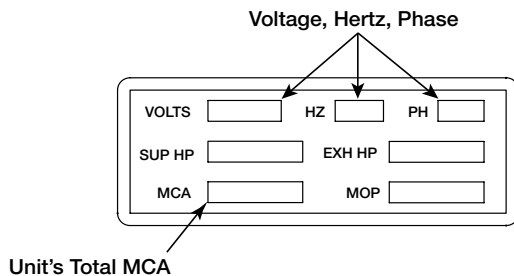

2. **Connect the Main Power:** Connect the power line to the disconnect switch. The electrical supply must be compatible with the fan motor with regards to voltage, phase, and amperage capacity. Moreover, the electrical supply line must be properly fused and conform to local and national electrical codes. Electrical wires must be located so as not to rub on moving components.

### IMPORTANT

If fan motor is not thermally protected, remote overload protection must be installed having the adequate rating as to voltage, frequency horsepower, and full load current per phase.

## Start-Up – Blower

**Pre-Start-Up Check:** Rotate the fan wheel by hand and make sure no parts are rubbing. Check the V-belt drive (KSFB only) for proper alignment and tension (a guide for proper belt tension and

alignment is provided in the belt maintenance section). Check fasteners, set screws and locking collars on the fan, bearings, drive (KSFB only), motor base and accessories for tightness.

### WARNING

Disconnect and lock-out all power before performing any maintenance or service to the unit. Failure to do so could result in property damage and serious injury or death.

### SPECIAL EQUIPMENT REQUIRED

Required and recommended tools. Equivalent products may be used.

Voltage & Amperage Meter	Manufacturer: Fluke
	Model: 177
Tachometer	Phone: 1-800-44-FLUKE
	www.fluke.com
	Manufacturer: Monarch
	Model: Pocket Tach 100
	Phone: 1-800-999-3390
	www.monarchinstrument.com

- Check the Voltage:** Before starting the unit, compare the supplied voltage, hertz, and phase with the unit and motor nameplate information.
- Check the Blower Rotation:** Remove the housing cover and run the blower momentarily to determine the rotation. Arrows are placed on the blower scroll to indicate the proper direction. If the blower is rotating in the wrong direction, the unit will move some air, but will not perform as designed. Be sure to perform a visual inspection to guarantee the correct blower rotation.

### TO REVERSE ROTATION

To reverse the rotation, disconnect and lock-out the power.

**Single Phase:** Rewire the motor per the manufacturer's instructions.

**Three Phase:** Interchange any two power leads.

- Check for Vibration:** Check for unusual noise, vibration or overheating of the bearings and take corrective action.  
Excessive vibration may be experienced during the initial start-up. Left unchecked, it can cause a multitude of problems, including structural and/or component failure.  
Generally, fan vibration and noise is transmitted to other parts of the building by the ductwork. To minimize this undesirable effect, the use of heavy canvas connectors is recommended.
- Motor Check:** Measure the motor's voltage, amps and RPM. Compare to the specifications. Motor amps can be reduced by lowering the motor RPM or increasing system static pressure.

5. **Air Volume Measurement and Check:** Measure the unit's air volume (cfm) and compare it with its rated air volume. If the air volume is off, adjust the belts and drives (KSFB) or speed controller (KSFD) until the specified air volume is reached.

The most accurate method for measuring the air volume is a pitot traverse method downstream of the blower. Other methods can be used, but should be proven and accurate.

**WARNING**

Changing the belts or drives can significantly increase the amp draw of the motor. If changes are made to the drives or belts, the amps must be checked to assure no over-amping.

**Maintenance**

**WARNING**

Disconnect and lock-out all power before performing any maintenance or service to the unit. Failure to do so could result in property damage and serious injury or death.

**V-Belt Drives (KSFB only)** – V-belt drives must be checked on a regular basis for wear, tension, alignment and dirt accumulation. Check the alignment by using a straight edge across both sheaves and the tension by measuring the deflection in the belt as shown.

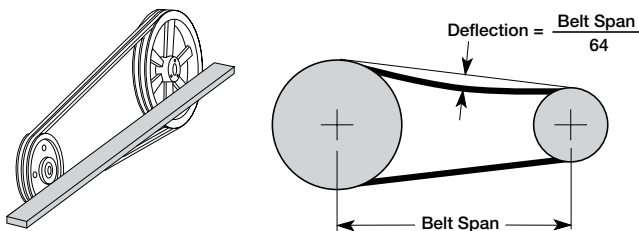

- Improper belt tension and/or misaligned sheaves lead to premature and frequent belt failures.
- Do not pry belts on or off the sheave. Loosen belt tension until belts can be removed by gently lifting them off of the sheaves.
- When replacing V-belts on multiple groove drives, all belts should be changed to provide uniform drive loading.
- Do not install new belts on worn sheaves. If the sheaves have grooves worn in them, they must be replaced before new belts are installed.

**Wheels** – Wheels require little attention when moving clean air. Occasionally, oil and dust may accumulate on the wheel causing imbalance. When this occurs the wheel and housing should be cleaned to assure proper operation.

**Filters** – Filter maintenance is generally limited to cleaning and replacement. The filters in the unit should be inspected at least every three (3) months. Depending on the environment, filters could require

changing or cleaning more or less often.

Aluminum mesh filters can be washed in warm soapy water. An adhesive spray can be added to increase the filter efficiency.

- Be sure to reinstall filters with the airflow in the correct direction. An airflow direction arrow is located on the side of the filters.
- Replacement filters should be from the same manufacturer and be the same size as the original filters provided with the unit.

**Motors** – Motor maintenance is generally limited to cleaning and lubrication (where applicable).

Cleaning should be limited to exterior surfaces only. Removing dust and grease build-up on the motor assures proper motor cooling.

Motors supplied with grease fittings should be greased in accordance with the manufacturer's recommendations.

- Greasing of motors is only intended when fittings are provided. Many fractional horsepower motors are permanently lubricated and will not require additional lubrication.

**CAUTION**

Do not allow water or solvents to enter the motor or bearings. Under no circumstances should motors or bearings be sprayed with steam, water or solvents.

**Maintenance Details**

Unit Model Number \_\_\_\_\_  
 (e.g. KFSB-115-H25)

Unit Serial Number \_\_\_\_\_  
 (e.g. 04C99999 or 10111000)

Start-Up Date \_\_\_\_\_

Start-Up Personnel Name \_\_\_\_\_

Start-Up Company \_\_\_\_\_

Phone Number \_\_\_\_\_

**Pre Start-Up Checklist** – check boxes as items are completed.

- Check tightness of all factory wiring connections
- Hand-rotate blower to verify free rotation
- Verify supply voltage to the main disconnect

**Start-Up Blower Checklist** – refer to IOM for further detail.

- Check line voltage L1-L2 \_\_\_\_\_  
L2-L3 \_\_\_\_\_  
L1-L3 \_\_\_\_\_
- Check blower rotation
- Check for vibration
- Supply fan RPM \_\_\_\_\_ RPM
- Motor nameplate amps \_\_\_\_\_ Amps
- Actual motor amps \_\_\_\_\_ Amps
- Actual CFM delivered \_\_\_\_\_ CFM



## Reference

### Standard HZ and DB3 Weatherhood Assembly Instructions

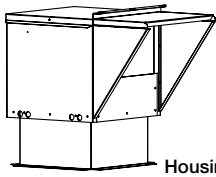

Housing 05 HZ

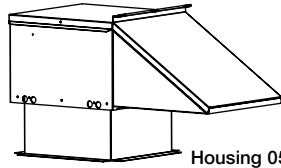

Housing 05 DB3

#### TOOLS REQUIRED

- 5/16 inch nut runner
- Caulk gun with weatherproof sealant

The KSFB/D Standard HZ and DB3 weatherhoods are folded up and shipped on top of the unit.

To install:

1. Rotate one side up on weatherhood.
  - a. Run one (1) sheet metal screw where shown to hold side in rotated position.
  - b. Rotate opposite side up on weatherhood and repeat step 1A.
2. Rotate assembly forward.
3. Screw the sides of the weatherhood to the unit. Pilot holes are provided.

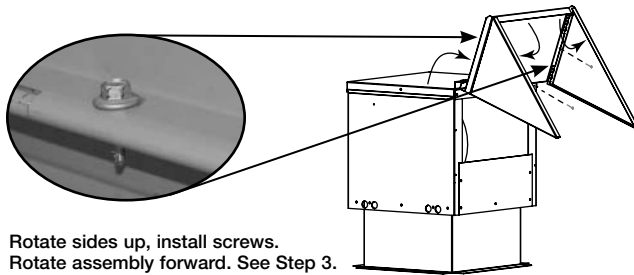
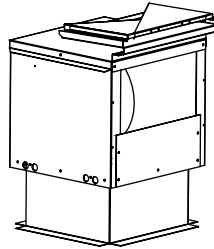

Rotate sides up, install screws.  
Rotate assembly forward. See Step 3.

4. Caulk all seams with an appropriate weatherproof sealant.
5. There are four housing sizes: H05, H08, H15, and H25.

- The H05 housing requires a single filter at the face of the intake hood.
- The H08, H15, and H25 housings require multiple filters installed at the face of the intake hood.

As such, these three units require installation of an additional center track (two pieces) to support the multiple filters. The filters and center track pieces are shipped inside the KSFB/D housing. Slide the tabbed end of each track into the slot at the bottom of the intake opening on the unit housing. Rotate the tracks up to the top outer edge of the weatherhood such that the weatherhood edge slides into the slot in the tracks.

6. Insert the factory provided aluminum mesh intake filter(s) into the track located in the face of the weatherhood. Filters slide in from the top. Be sure the filters are properly orientated (an airflow direction arrow is located on the side of the filters).

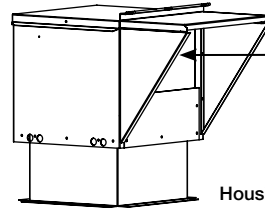

Track for aluminum mesh intake filters.

Housing 05 HZ

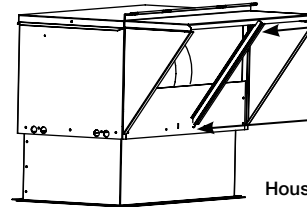

Center filter track (2 pieces)

Slot in unit

Housing 05, 08, 15 & 25 HZ

### Extended 10 ft. DBC Weatherhood Assembly Instructions

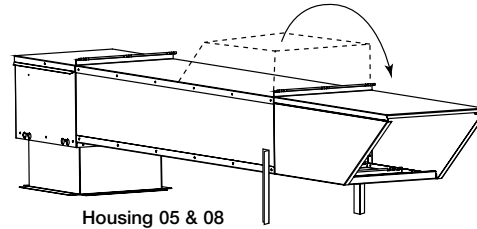

Housing 05 & 08

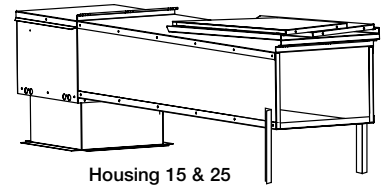

Housing 15 & 25

The KSFB/D extended 10 ft. weatherhood is made up of up to three parts: 1) a fixed section attached to the unit, 2) a folded up section shipped on top of the fixed section, and 3) an assembled section shipped on top of the fixed section. This three part assembly applies to both the DB and HZ arrangements.

To install:

1. Lift unit onto curb. Prior to disconnecting from crane, adjust support legs on fixed section of the extended weatherhood to appropriate height to support hood.
2. For housing sizes H05 and H08, rotate the assembled section of the weatherhood forward.
3. For housing sizes H15 and H25, rotate one side up on the weatherhood.
  - a) Run one (1) sheet metal screw where shown to hold side in rotated position.
  - b) Rotate opposite side up on weatherhood and repeat step 3A.

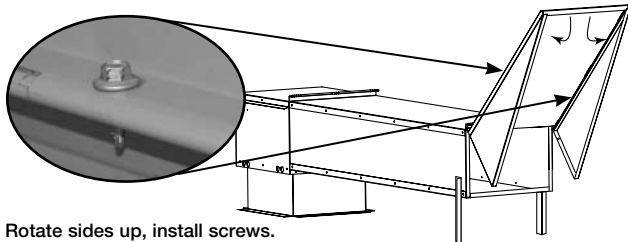

Rotate sides up, install screws.  
Rotate assembly forward. See Step 3.

4. Screw the sides (and bottom on Housing 05 & 08) of the weatherhood to the unit. Pilot holes are provided.
5. Caulk all seams with an appropriate weatherproof sealant.
6. There are four housing sizes: H05, H08, H15, and H25. The H05 housing requires a single filter at the face of the intake hood. The H08, H15, and H25 housings require multiple filters installed at the face of the intake hood. As such, these three units require installation of an additional center track (two pieces) to support the multiple filters.

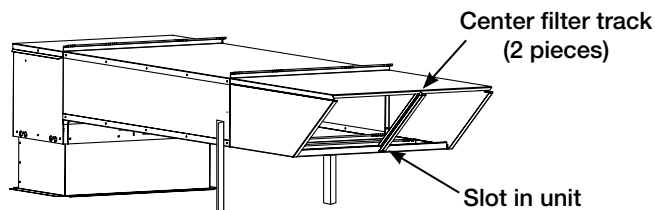

The filters and center track pieces are shipped inside the KSFB/D housing. Slide the tabbed end of each track into the slot at the bottom of the intake opening. Rotate the tracks up to the top outer edge of the weatherhood such that the weatherhood edge slides into the slot in the tracks.

7. Insert the factory provided 1-inch aluminum mesh intake filter(s) into the track located in the face of the weatherhood. Filters slide in from the top. Be sure the filters are properly orientated (an airflow direction arrow is located on the side of the filters).

**NOTE:** Housing 15 & 25 have no bottom section to the weatherhood.

## Warranty

Greenheck warrants this equipment to be free from defects in material and workmanship for a period of one year from the purchase date. Any units or parts which prove defective during the warranty period will be replaced at our option when returned to our factory, transportation prepaid. Motors are warranted by the motor manufacturer for a period of one year. Should motors furnished by Greenheck prove defective during this period, they should be returned to the nearest authorized motor service station. Greenheck will not be responsible for any removal or installation costs.

*As a result of our commitment to continuous improvement, Greenheck reserves the right to change specifications without notice.*

Greenheck Catalog Model KSFB and KSFD provides additional information describing the equipment, fan performance, available accessories, and specification data.

AMCA Publication 410-96, Safety Practices for Users and Installers of Industrial and Commercial Fans, provides additional safety information. This publication can be obtained from AMCA International, Inc. at: [www.amca.org](http://www.amca.org).

Contact Greenheck Fan Corporation:

Phone: (715) 359-6171 • Fax: (715) 355-2399 • E-mail: [gfcinfo@greenheck.com](mailto:gfcinfo@greenheck.com) • Website: [www.greenheck.com](http://www.greenheck.com)

