

MODEL DG / DGX (Direct Spark Ignition) Make-Up Air Unit

Installation, Operation and Maintenance Manual

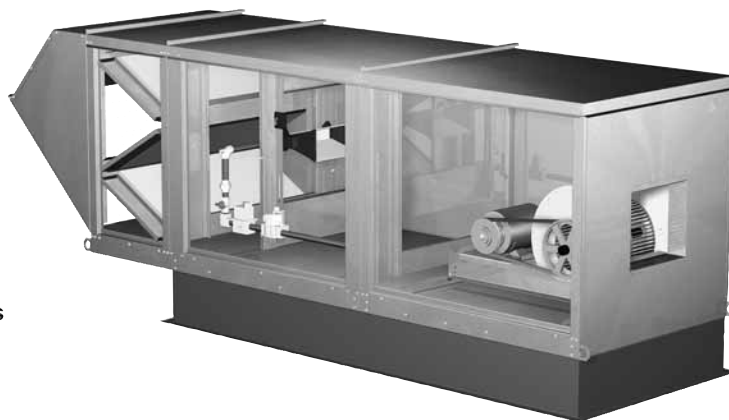

Installation

FOR YOUR SAFETY

If you smell gas

1. Open windows
2. Don't touch electrical switches
3. Extinguish any open flames
4. Immediately call your gas supplier

FOR YOUR SAFETY

The use and storage of gasoline or other flammable vapors and liquids in open containers in the vicinity of this appliance is hazardous.

Start-Up

WARNING

Disconnect and secure all electrical power to the "OFF" position prior to inspection or servicing. Failure to comply with this safety precaution could result in serious injury or death.

Operation

WARNING

Improper installation, adjustment, alteration, service or maintenance can cause property damage, injury or death. Read the installation, operating, and maintenance instructions thoroughly before installing or servicing this equipment.

Troubleshooting

IMPORTANT

All factory provided lifting lugs must be used when lifting any unit. Failure to comply with this safety precaution could result in property damage, serious injury or death.

Maintenance

Report any damaged equipment to the shipper immediately!

All units are shipped on a skid or packaged to minimize damage during shipment. The transporting carrier has the responsibility of delivering all items in their original condition as received from Greenheck. The individual receiving the equipment is responsible for inspecting the unit for obvious or hidden damage, recording any damage on the bill of lading before acceptance and filing a claim (if required) with the final carrier. Some accessory items are stored inside the unit during shipping. Care must be taken during installation to prevent damage to units.

Reference

TABLE OF CONTENTS

I Installation

- Clearance to Combustibles & Service Clearances2
- Unit - Indoor3
- Unit - Arrangement DB/HZ4
- Unit - Arrangement DBC5-6
- Evaporative Module7
- Electrical Wiring8-9
- Direct Gas Piping10-11
- Evaporative Cooler Piping12-13
- Water Wizard™14
- Direct Expansion (DX) Coil Piping ...15-16
- Chilled Water Coil Piping17
- Building Pressure Control18

S Start-Up

- Blower19-20
- Direct Gas21-25
- Evaporative Cooling26
- Water Wizard™27-28

O Operation

- VAV and Recirculation Units29-30
- Electrical31
- Water Wizard™32

T Troubleshooting

- Blower33
- Heater34-35
- Evaporative Cooling36
- Water Wizard™37
- Vibration38

M Maintenance

- Routine39-41
- Fall42-43

R Reference

- Gas Train Layout44
- Control Center Layout45
- Dirty Filter Switch45
- Start-Up Checklist46
- Maintenance Log47
- WarrantyBackcover

STORAGE

When a unit is not going to be in service for an extended period of time, certain procedures should be followed to keep the unit in proper operating condition:

- Plug all piping
- Rotate fan wheel monthly and purge bearings once every one to three months (depending on environment).
- Energize fan motor once every three months
- Store belts flat to keep them from warping and stretching
- Store unit in location without vibration
- Cover unit with tarp to protect from dirt and moisture
- After storage period, purge grease before putting fan into service

NOTE!

Do not cover unit with a black tarp, this would promote condensation.

NOTE!

Improper storage which results in damage to the unit will void the warranty.

Clearance to Combustibles / Service Clearances

	Floor	Top	Sides	Ends
Insulated Units	0 inches	0 inches	0 inches	0 inches
Non Insulated Units	0 inches	6 inches	6 inches	6 inches

Clearance to combustibles is defined as the minimum distance required between the heater and adjacent combustible surfaces to ensure the adjacent surface's temperature does not exceed 90 degrees above the ambient temperature.

Recommended Minimum Service Clearances	
Housing 32 and less	42 inches on the controls side of the unit
Housing 35 and higher	48 inches on the controls side of the unit

Clearances for component removal may be greater than the service clearances listed.

Installation - Indoor Installation

Step 1 Install Hangers

Install threaded hangers from ceiling supports. When locating hangers, allow enough room to open access panel(s). Two nuts must be used on the end of each threaded hanger. Ceiling supports are supplied by others.

Step 2 Install Unit

Using sheet metal screws, attach the weatherhood/thru-wall/filter section to the blower/burner section. The flange on the weatherhood/thru-wall/filter section should overlap the flange on the blower/burner section.

Raise the assembled unit into place.

Using two nuts per hanger, fasten the unit supports to the hangers under the unit. Appropriate unit supports, such as the optional Greenheck hanging bracket kit or c-channel and angle iron (supplied by others) should be used.

Using self-tapping screws, attach ductwork to unit.

In order to prevent the unit from swinging and to provide a safe environment for service and maintenance, additional measures must be taken to secure the unit in all directions.

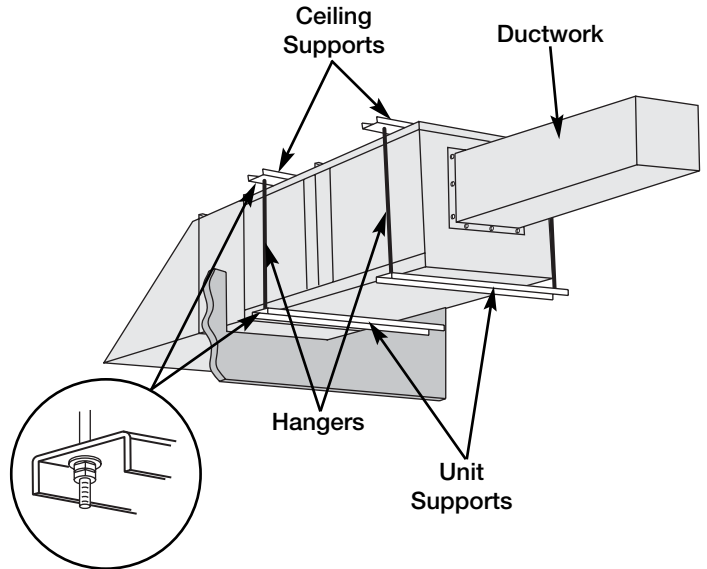

Installation

Indoor Mounting

NOTE!

Two nuts must be used on each end of each threaded hanging rod for proper support.

NOTE!

Good duct practices should be followed for all ductwork. Ductwork should be installed in accordance with SMACNA and AMCA guidelines, NFPA 96 and any local codes. Reference the CAPS submittal for duct sizes.

Step 3 Seal Wall Opening

Apply sealant around the perimeter of the weatherhood to prevent water penetration and drafts into the building.

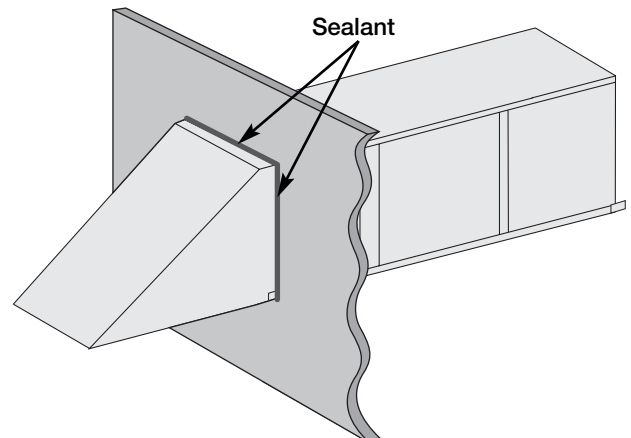

Sealing Wall Opening

Installation - Arrangement DB / HZ

Step 1 Install Curb and/or Equipment Support(s)

Position curb/equipment support(s) on the roof (reference the CAPS submittal for placement of curb/equipment support(s) in relation to the unit). Verify that unit supports are level, shim if necessary. Attach curb to roof and flash into place. Attach the equipment support(s) to the roof, remove metal cover, flash to wooden nailer and reinstall cover.

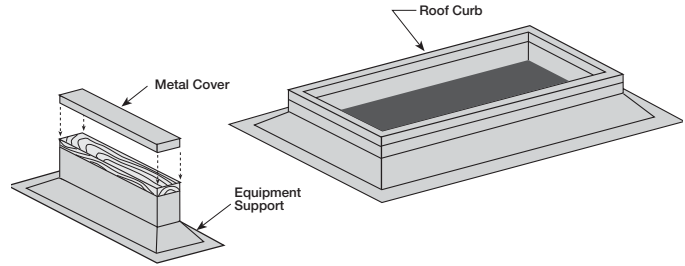

Roof Curb

NOTE!

The use of a duct adapter is recommended on a downblast (DB) arrangement to align the ductwork with the supply unit. The duct adapter is only a guide and is not to be used as support for the ductwork.

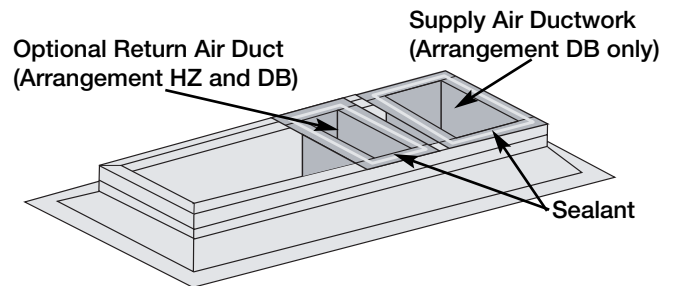

Ductwork

Step 3 Apply Sealant

Apply an appropriate sealant around the perimeter of the curb and duct adapter(s) to isolate fan vibration and prevent water penetration.

Step 4 Install Unit

Use a crane and a set of spreader bars hooked to the factory lifting lugs to lift and center the unit on the curb/equipment support(s).

Use self-tapping sheet metal screws to fasten the unit to the curb/equipment support(s).

NOTE!

The use of all lifting lugs and a set of spreader bars is mandatory when lifting the unit.

NOTE!

Some units come with the weatherhood attached and step 5 may not apply.

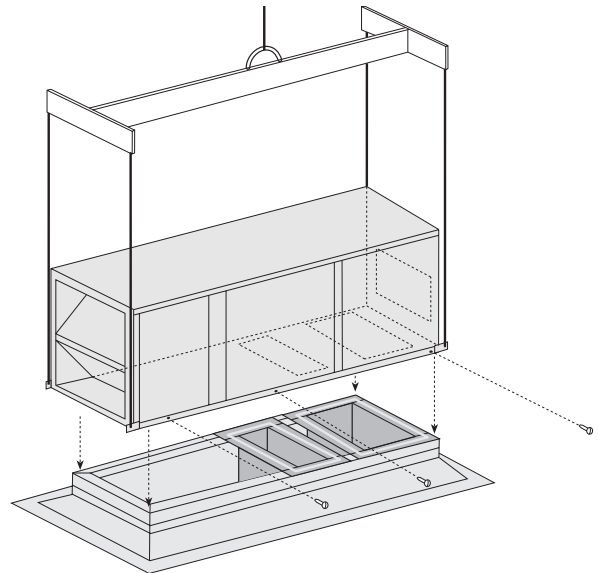

Setting Unit

Step 5 Assemble and Attach Weatherhood

The weatherhood can now be assembled and attached to the unit. Detailed assembly instructions can be found with the weatherhood. If the optional evaporative cooling module was selected, this step does not apply, refer to the installation instructions for the optional evaporative cooling module.

Step 6 Seal Weatherhood Seam

Using an appropriate sealant, seal the seam between the weatherhood and the unit.

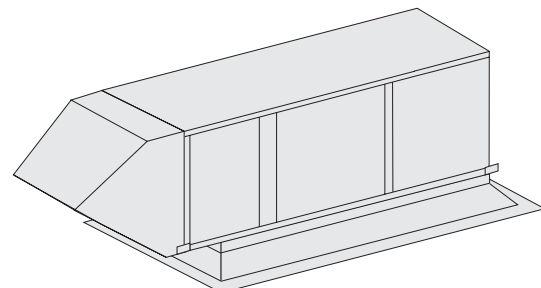

Complete Rooftop Installation

Installation - Roof Mounted Unit Arrangement DBC

Step 1 Install Curb/Equipment Support(s)

Position curb/equipment support(s) on the roof (reference the CAPS submittal for placement of curb/equipment support(s) in relation to the unit). Verify that all unit supports are level, shim if necessary. Attach curb to roof and flash into place. Attach the equipment support(s) to the roof, remove metal cover, flash to wooden nailer and reinstall cover.

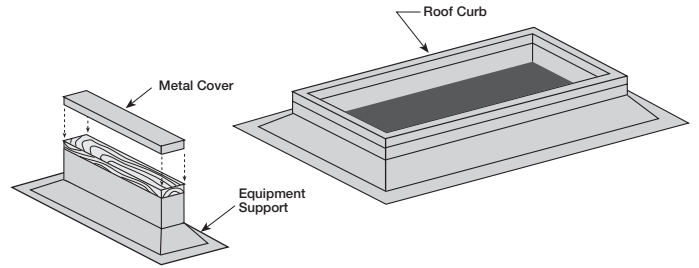

Curb and Equipment Support

Step 2 Install Combination Extension

Install combination extension over curb. Lag into place using wood screws. Locate the extension so the tall vented side is over the exhaust opening.

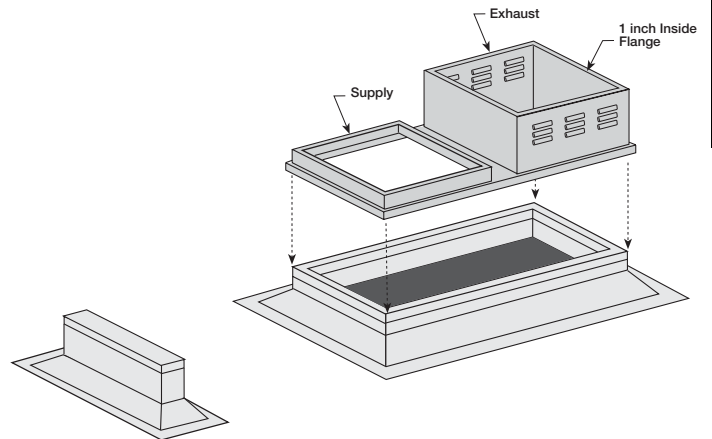

Combination Extension

Step 3 Install Ductwork

Good duct practices should be followed for all ductwork. All ductwork should be installed in accordance with SMACNA and AMCA guidelines, NFPA 96 and any local codes. Reference the CAPS submittal for ductwork size and location.

NOTE!

The use of a duct adapter is recommended on a downblast (DBC) arrangement to align the ductwork with the supply unit. The duct adapter is only a guide and is not to be used as support for the ductwork.

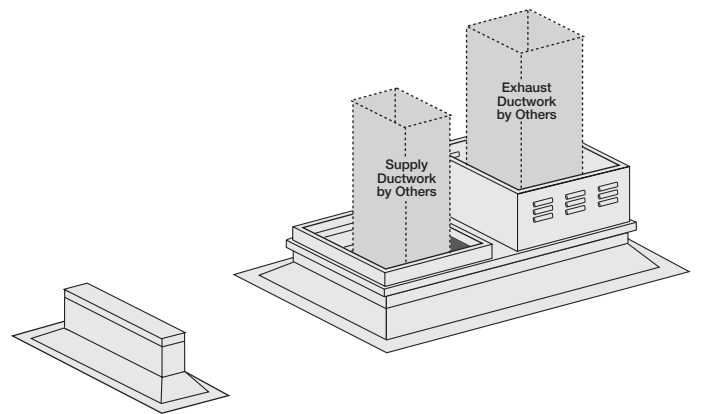

Ductwork

Step 4 Apply Sealant

Apply an appropriate sealant around the perimeter of the curb and duct adapter(s) to isolate fan vibration and prevent water penetration.

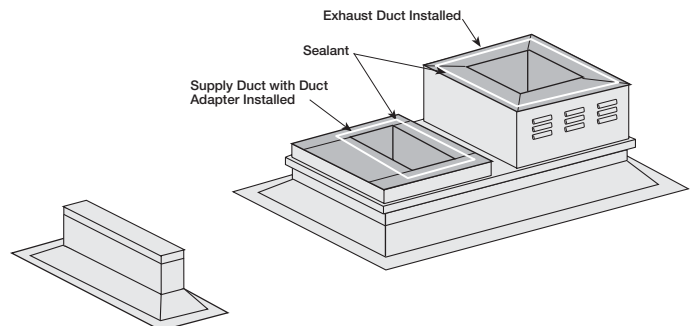

Sealing Ductwork

Installation - Roof Mounted Unit Arrangement DBC

Step 5 Install Exhaust Fan

Fasten exhaust fan to curb extension with self-tapping sheet metal screws.

NOTE!

Installing the exhaust fan prior to the supply unit will allow for easier installation of options.

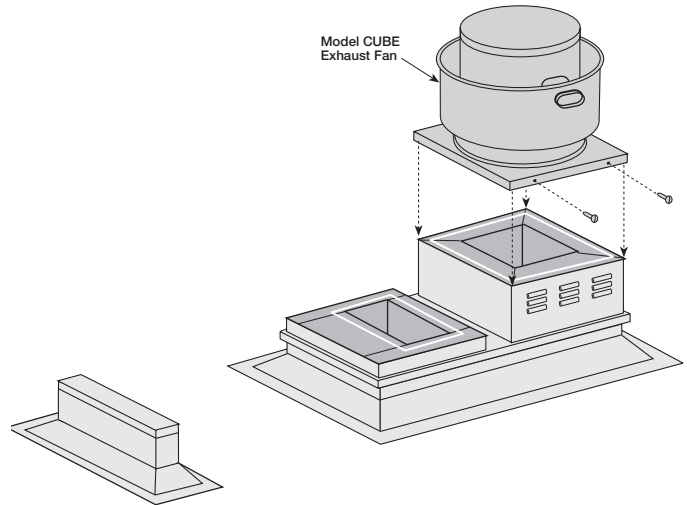

Installing Exhaust Fan

Step 6 Install Exhaust Options

Install optional Greenheck hinge kit with restraining cables and grease trap with drain connection.

Step 7 Install Supply Unit

Use a crane and a set of spreader bars hooked to the factory lifting lugs to lift and center the unit on the extension/equipment support(s).

Use self-tapping sheet metal screws to fasten the unit to the extension/equipment support(s).

NOTE!

The use of all lifting lugs and a set of spreader bars is mandatory when lifting unit.

NOTE!

Some units come with the weatherhood attached and step 8 may not apply.

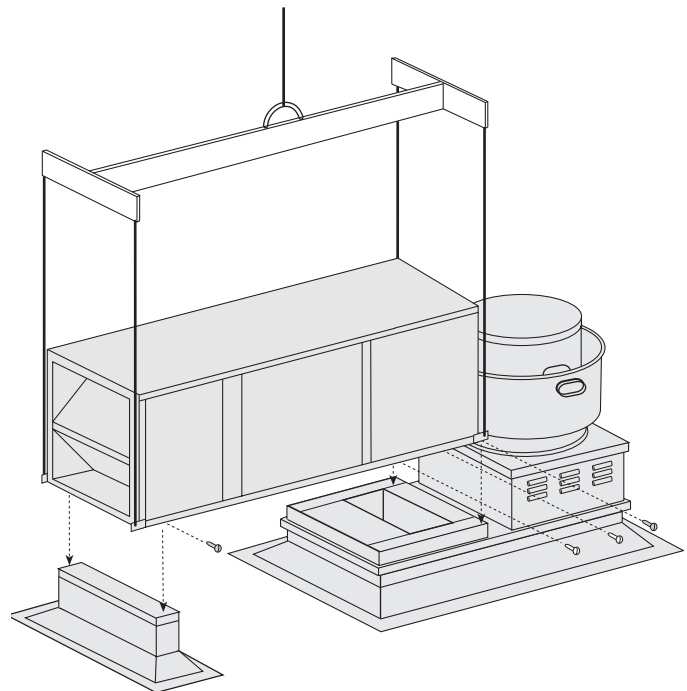

Installing Supply Unit

Step 8 Assemble and Attach Weatherhood

The weatherhood can now be assembled and/or attached to the unit. Detailed assembly instructions can be found with the weatherhood. If the optional evaporative cooling module was selected, this step does not apply, refer to the installation instructions for the optional evaporative cooling module.

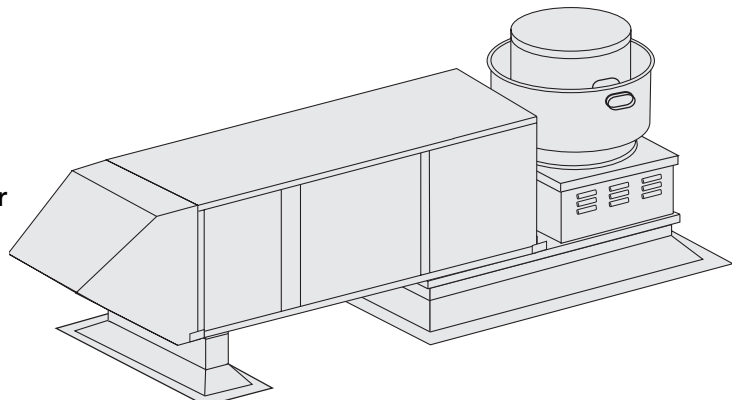

Complete Combination Installation

Step 9 Seal Weatherhood Seam

Using an appropriate sealant, seal the seam between the weatherhood and the unit.

Installation - Evaporative Module (Optional)

NOTE!

Small evaporative coolers ship attached to the base unit and require no additional mounting.

Step 1 Locate Equipment Support(s)

Position equipment support(s) on the roof (reference the CAPS submittal for placement of equipment support(s) in relation to the unit). Verify that all unit supports are level, shim if necessary. Attach equipment support to the roof, remove metal cover, flash to wooden nailer and reinstall cover.

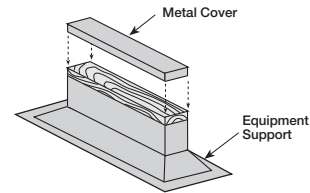

Equipment Support

Step 2 Apply Sealant

Apply an appropriate sealant around the airstream opening to create an air tight seal.

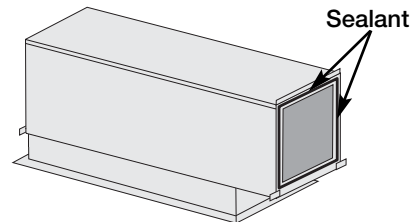

Sealant

Step 3 Set Evaporative Cooling Module

Use a crane and a set of spreader bars hooked to the factory lifting lugs to lift and center the module on the equipment support(s). The flange on the evaporative cooler should overlap the flange on the unit.

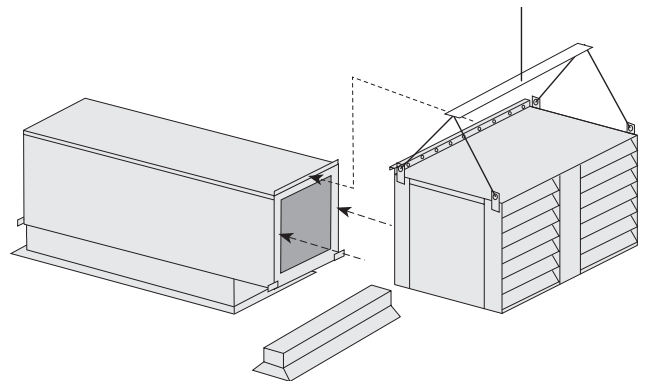

Placing Evaporative Module

NOTE!

The use of all lifting lugs and a set of spreader bars is mandatory when lifting the evaporative cooling module.

Step 4 Secure Cooling Module to Unit

Use self-tapping screws to fasten the cooling module to the base unit along the top and down both sides. Fasten at the top through the flanges. To fasten the sides, the media must be removed. To remove the media, first remove the access panel on the evaporative module and disconnect the evaporative pump(s). The media will now slide out. With the media removed, you can access the side fastening points inside the evaporative module. With all the screws in place, reinstall the media, reconnect the pumps and reinstall the access panel.

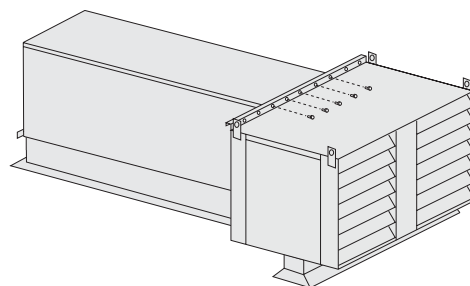

Securing Evaporative Module

NOTE!

When mounting the evaporative cooler, it is important that it is level to ensure proper operation and water drainage.

Installation - Electrical Wiring

IMPORTANT!

Before connecting power to the unit, read and understand the following instructions and wiring diagrams. Complete wiring diagrams are attached to the inside of the control center door(s).

IMPORTANT!

All wiring should be done in accordance with the latest edition of the National Electrical Code ANSI/NFPA-70 and any local codes that may apply. In Canada, wiring should be done in accordance with the Canadian Electrical Code.

CAUTION!

If replacement wire is required, it must have a temperature rating of at least 105°C, except for energy cut-off or sensor lead wire which must be rated to 150°C.

IMPORTANT!

The equipment must be properly grounded. Any wiring running through the unit in the airstream must be protected by metal conduit, metal clad cable or raceways.

DANGER!

High voltage electrical input is needed for this equipment. This work should be performed by a qualified electrician.

CAUTION!

Any wiring deviations may result in personal injury or property damage. Greenheck is not responsible for any damage to, or failure of the unit caused by incorrect final wiring.

IMPORTANT!

Greenheck's standard control voltage is 24 VAC.

Control wire resistance should not exceed 0.75 ohms (approximately 285 feet total length for 14 gauge wire; 455 feet total length for 12 gauge wire). If the resistance exceeds 0.75 ohms an industrial-style, plug-in relay should be wired in place of the remote switch. The relay must be rated for at least 5 amps and have a 24 VAC coil. Failure to comply with these guidelines may cause motor starters to chatter or not pull in, resulting in contactor failures and/or motor failures.

Step 1 Determine the Size of the Main Power Lines

The units nameplate states the voltage and the unit's MCA. The main power lines to the unit should be sized accordingly. The nameplate is located on the outside of the unit on the control panel side.

Step 2 Provide the Opening(s) for the Electrical Connections

Electrical openings vary by unit size and arrangement and are field supplied.

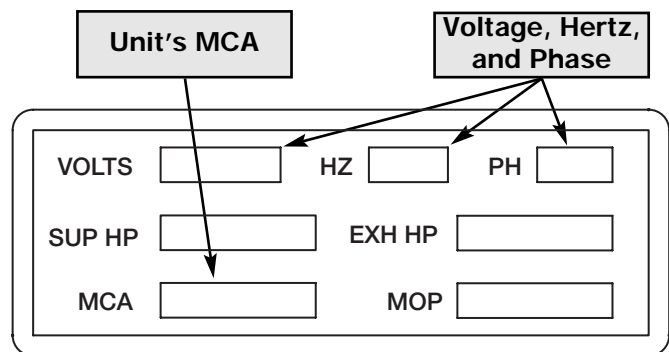

Electrical Nameplate

Step 3 Connect the Main Power

Connect the main power lines to the disconnect switch and main grounding lug(s). Torque field connections to 20 in-lbs. See the control center layout in the reference section for main disconnect and grounding lug(s) locations.

Step 4 Wire the Optional Convenience Outlet

The convenience outlet requires a separate 115V power supply circuit. The circuit must include short circuit protection which may need to be supplied by others.

Installation - Electrical Wiring

Step 5 Wire the Accessories

Reference the ladder diagram on the inside of the control center door for correct wiring of the following accessories:

- Selectra Stat
- Room Override
- Blower Switch
- Heat Switch
- Indicating Lights
- Dirty Filter Indicator
- TSCP
- KSCP

Step 6 Wire the Optional Evaporative Cooler

Reference the ladder diagram on the inside of the control center door for correct wiring of the pump and the optional auto-drain and flush.

Step 7 Check Recirculation / VAV Operation

NOTE!

Blower Start-Up, steps 1-4 should be performed before the blower is run.

Two Position Damper Control

Turn the recirculating switch on the remote control panel to each position and confirm that the return air damper adjusts accordingly. The damper actuator may take a few minutes to open or close.

Two Speed

Turn the fan speed switch on the remote control panel to each positions and confirm that the fan speed adjusts accordingly.

Potentiometer Control

To test potentiometer operation, turn the potentiometer to the two extremes. With 80/20 recirculation, confirm that the return air damper fully opens and fully closes. The damper actuator may take a few minutes to open or close. With variable volume, make sure the fan goes to maximum and minimum speed.

Building Pressure Control

See Installation - Building Pressure control for building pressure set-up and operation check.

External Signal Control

See Operation-VAV and Recirculating units for additional information. External 2-10 VDC / 4-20 mA signal required.

NOTE!

For maintenance issues associated with variable frequency drives, consult the drive's manual supplied with the unit. The drives are programmed at the factory and should not need any adjustment during installation and start-up. For kitchen applications, the drive may be located in the kitchen or in the unit.

NOTE!

Wiring to the Selectra Stat should be in separate conduit or run with shielded cable.

NOTE!

TSCP has number-to-number wiring.

NOTE!

Large evaporative coolers may require a separate power supply.

Installation

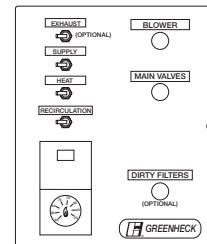

2-Position Damper Control

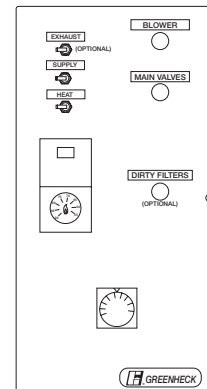

Potentiometer Control

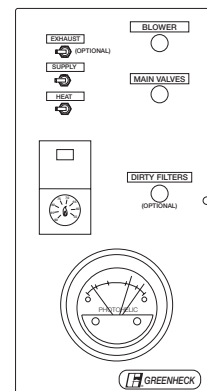

Building Pressure Control

Installation - Direct Gas Piping

IMPORTANT!

All gas piping must be installed in accordance with the latest edition of the National Fuel Gas Code ANSI/Z223.1 and any local codes that may apply. In Canada, the equipment shall be installed in accordance with the Installation Code for Gas Burning Appliances and Equipment (CGA B149) and Provincial Regulations for the class. Authorities having jurisdiction should be consulted before installations are made.

WARNING!

All components of this or any other gas fired heating unit must be leak tested prior to placing the unit into operation. A soap and water solution should be used to perform this test. NEVER test for gas leaks with an open flame.

WARNING!

If pressure testing in excess of 1/2 psig (3.5 kPa), the heater and manual shutoff valve must be disconnected from the supply gas line.

WARNING!

If pressure testing at or below 1/2 psig (3.5 kPa), the heater must be isolated from the supply gas line by closing its manual shutoff valve.

IMPORTANT!

All piping should be clean and free of any foreign matter. Foreign material entering the gas train can damage the valves, regulators and burner.

IMPORTANT!

Do NOT connect the unit to gas types other than what is specified and do NOT connect the unit to gas pressures that are outside of the pressure range shown on the label.

Step 1 Determine the Supply Gas Requirements

The unit's direct gas nameplate states the requirements for the gas being supplied to the unit. The direct gas nameplate is located on the outside of the unit on the control center side.

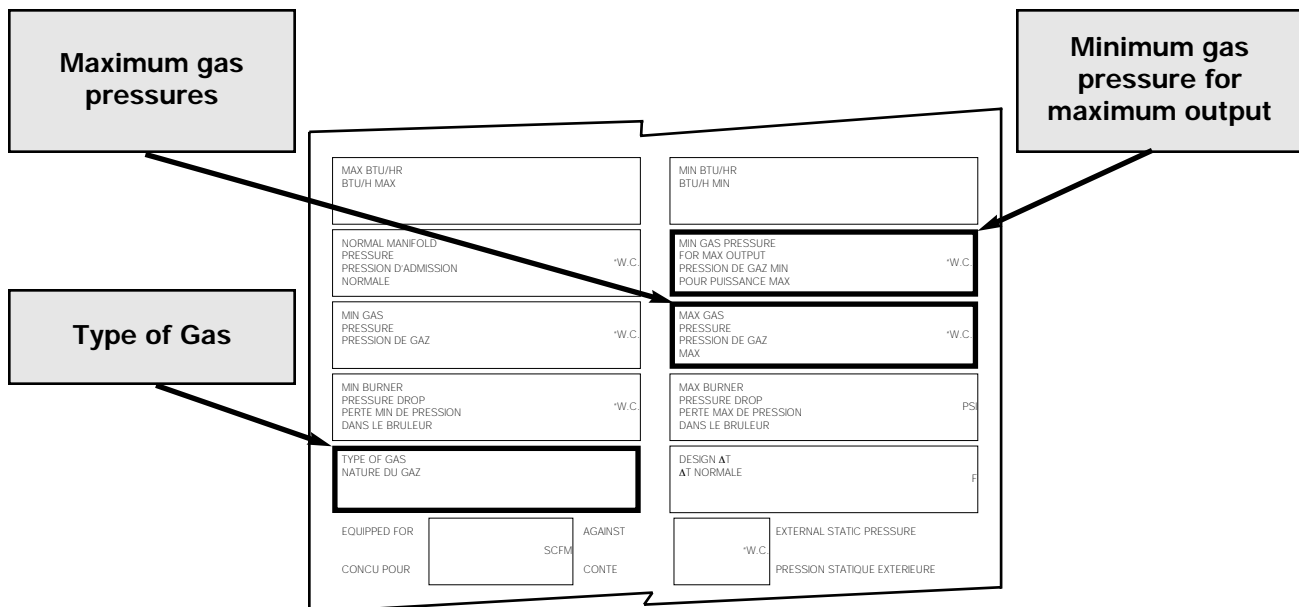

Direct Gas Nameplate

Installation - Direct Gas Piping

Step 2 Install Additional Regulator if Required

When the supply gas pressure exceeds the maximum gas pressure shown on the direct gas nameplate, an additional regulator (by others) is required to reduce the pressure. The regulator must have a listed leak limiting device or it must be vented to the outdoors.

NOTE!
The regulator located inside the unit is used to adjust the unit's maximum output temperature.

Step 3 Connect the Supply Gas Line

A manual shut off valve (gas cock), 1/8 in. plugged test port and 6 in. drip leg must be installed prior to the gas train. The valve and the test port must be accessible for the connection of a test gauge. Supply gas connections must be made by a qualified installer and are not furnished by Greenheck.

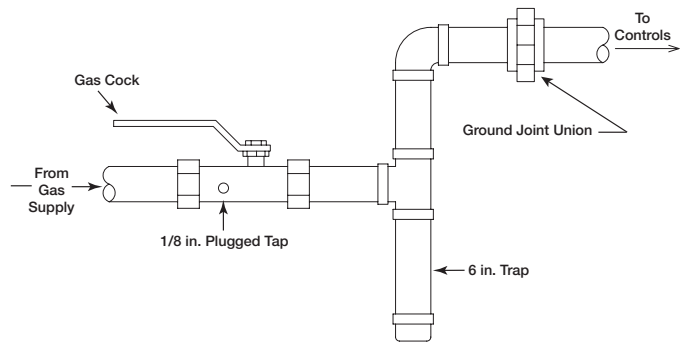

Supply Gas Line

Installation

Step 4 Test the System for Leaks

Check both the supply lines and the factory piping for leaks. Apply a soap and water solution to all piping and watch for bubbling which indicates a leak.

WARNING!
NEVER test for a gas leak with an open flame.

WARNING!
The factory piping has been checked for leaks, but should be rechecked due to shipping and installation.

Installation - Evaporative Cooling Piping (Optional)

Evaporative Cooling with Recirculating Pump

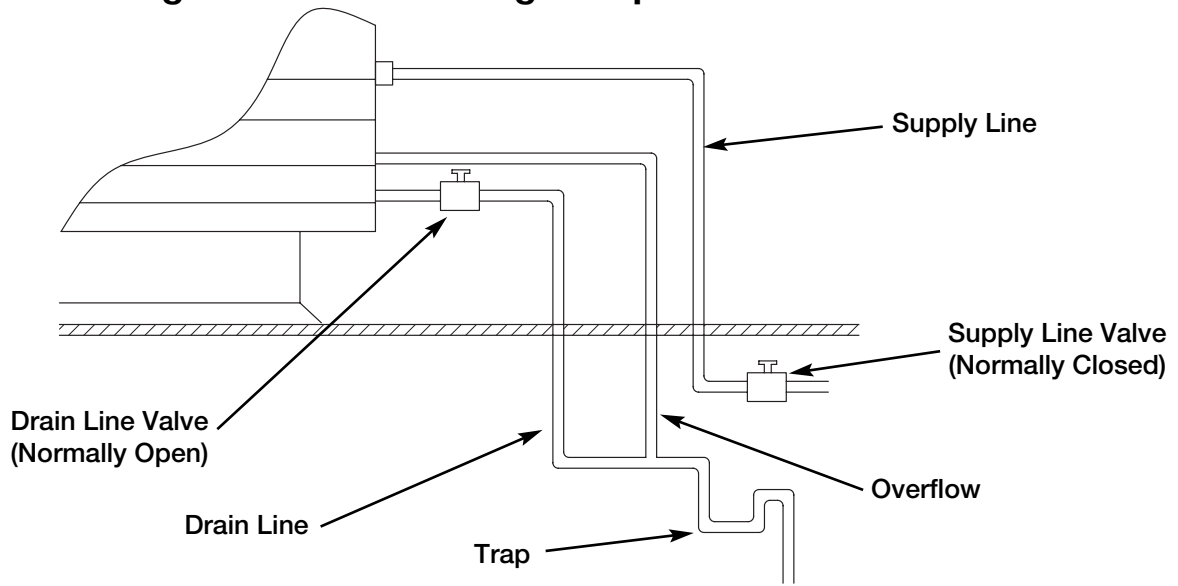

Recirculating Evaporative Piping

IMPORTANT!

All supply solenoids, valves and all traps must be below the roofline or be otherwise protected from freezing.

IMPORTANT!

The supply line should be of adequate size and pressure to resupply the amount of water lost due to bleed-off and evaporation. The drain line should be the same size or larger than the supply line.

CAUTION!

Provisions must be taken to prevent damage to the evaporative cooling section during freezing conditions. The sump, drain lines and supply lines must be drained prior to freezing conditions or an alternate method must be used to protect the lines and media.

Step 1 Install the Water Supply Line

Supply line opening requirements vary by unit size and arrangement and are field supplied. Connect the water supply line to the float valve through the supply line opening in the evaporative cooling unit. Install a manual shutoff valve in the supply line as shown above.

Step 2 Install the Drain Line

Connect an unobstructed drain line to the drain and overflow connections on the evaporative cooler. A manual shut off valve (by others) is required for the evaporative cooler drain line. A trap should be used to prevent sewer gas from being drawn into the unit. Refer to piping diagram above.

Step 3 Check/Adjust Water Level

Check the water level in the sump tank. The water level should be above the pump intake and below the overflow. Adjust the float as needed to achieve the proper water level.

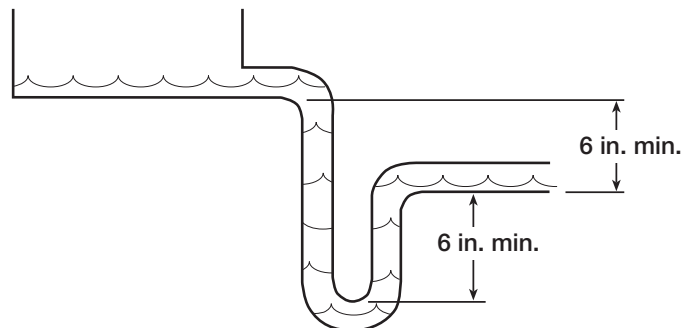

Drain Trap

Installation - Evaporative Cooler Piping (Optional)

Evaporative Cooling with Auto Drain and Fill

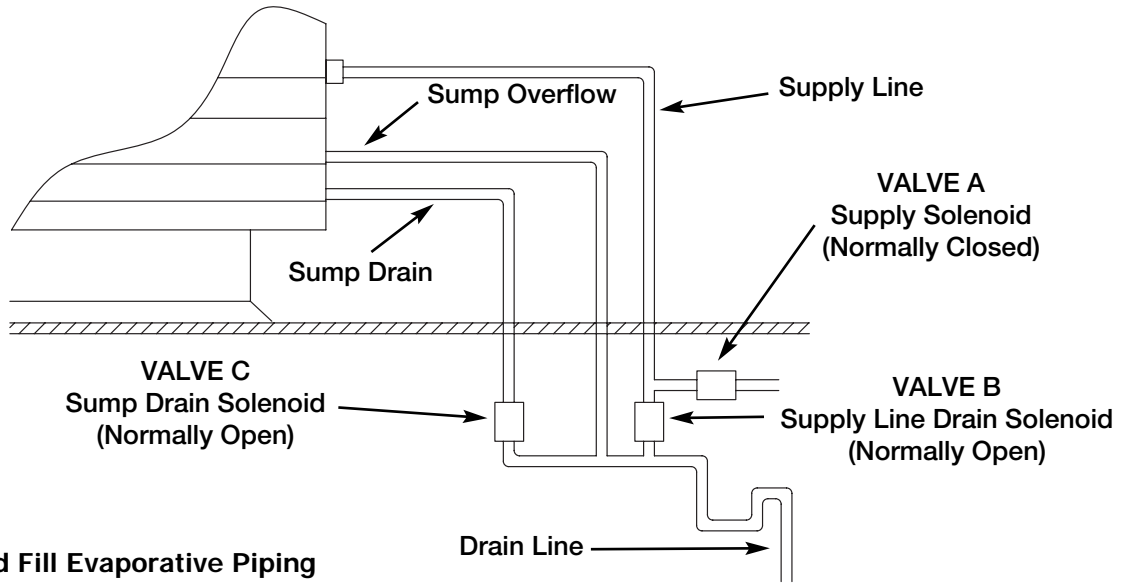

Auto-Drain and Fill Evaporative Piping

Installation

IMPORTANT!

The supply line should be of adequate size and pressure to resupply the amount of water lost due to bleed-off and evaporation. The drain line should be the same size or larger than the supply line.

CAUTION!

All solenoids valves and traps must be installed below the roof to protect the supply water line from freezing. If they cannot be installed below the roof, an alternative method must be used to protect the lines from freezing

IMPORTANT!

The supply solenoid (Valve A) is NOT the same as the drain solenoids (Valve B and Valve C). Make sure to use the proper solenoid for each location. Check you local code requirements for proper installation of this type of system.

Auto Drain & Flush Valves (when provided by Greenheck)

Assembly Number	GFC Part Number	ASCO Part Number	Solenoid Type	De-Energized Position	Diameter	Quantity
852178	461262	8210G2	Supply	Closed	1/2 inch	1
	461263	8262G62	Supply Line Drain	Open	1/4 inch	1
	461264	8210G35	Sump Drain	Open	3/4 inch	1

Part numbers subject to change.

Step 1 Install the Water Supply Line

Supply line opening requirements vary by unit size and arrangement and are field supplied. Connect the water supply line to the float valve through the supply line opening in the evaporative cooling unit. Install the 1/2 in. normally closed solenoid (Valve A) in the supply line as shown above. Install the 1/4 in. normally open solenoid (Valve B) between the supply line and the drain line as shown above.

Step 2 Install the Drain Line

Connect an unobstructed drain line to the sump drain overflow connection. Install the 3/4 in. normally open solenoid (Valve C) between the sump drain connection and the drain line. A trap should be used to prevent sewer gas from being drawn into the unit. Refer to piping drawing above.

Step 3 Check/Adjust Water Level

Check the water level in the sump tank. The water level should be above the pump intake and below the overflow. Adjust the float as needed to achieve the proper water level.

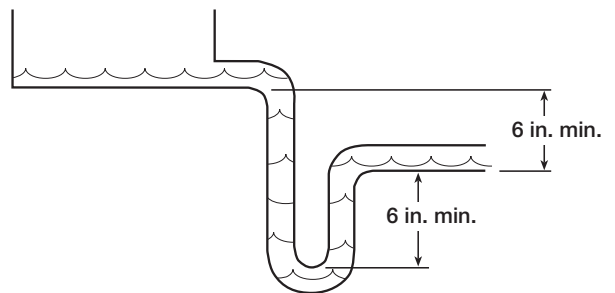

Drain Trap

Installation - Water Wizard™ (Optional)

Evaporative Cooling with the Water Wizard

NOTE!

The following instructions are provided for evaporative coolers equipped with the Water Wizard only. Additional instructions are provided for evaporative coolers equipped with the auto-drain and fill or bleed-off.

WARNING!

Disconnect and lock-out all power and gas before performing any maintenance or service to the unit. Failure to do so could result in serious injury or death and damage to equipment.

Water Wizard Valves (when provided by Greenheck)

Unit Model	Assembly Number	GFC Part Number	ASCO Part Number	Solenoid Type	De-Energized Position	Diameter	Quantity
DG0H10/H20 DGX-H12/H22 DGX-H30 (<9000 cfm)	852370	461262	8210G2	Supply	Closed	1/2 inch	1
		383086	8210G34	Supply Line Drain	Open	1/2 inch	1
DG-H30 DGX-H32 (≥9000 cfm)	852371	383088	8210G9	Supply	Closed	3/4 inch	1
		383086	8210G34	Supply Line Drain	Open	1/2 inch	1

Part numbers subject to change.

Step 1 Install Normally Closed Supply Line/Solenoid

Connect the water supply line to the manual supply valve in the unit. Install the supply solenoid in the supply line, upstream of the manual supply valve and below the roofline.

Step 2 Install Normally Open Drain Line/Solenoid

Connect the drain line to the supply line between the manual supply valve and the supply solenoid. Install a drain solenoid in the drain line, below the roof line. A trap should be installed in the drain line.

NOTE!

Solenoid(s) may be provided by Greenheck (if ordered) or by others.

CAUTION!

Any wiring deviations may result in personal injury or property damage. Greenheck is not responsible for any damage to, or failure of the unit caused by incorrect final wiring.

Step 3 Wire the Solenoid(s)

Wire the supply line solenoid and drain solenoid as shown on the unit's wiring diagram in the control center.

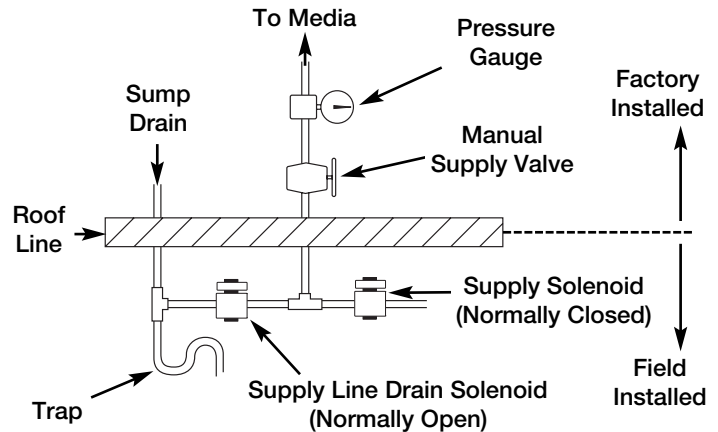

Water Wizard Installation

Step 4 Wire the Temperature Sensor

If the evaporative cooler shipped separate from the unit, the temperature sensor must be wired. The sensor wire is bundled inside the discharge end of the evaporative cooler. Wire the sensor wire to terminals AI2 and AIC on the terminal strip in the unit's control center.

NOTE!

The Water Wizard start-up must be completed for proper performance.

Installation

Installation - Direct Expansion (DX) Coil Piping (Optional)

IMPORTANT!

Guidelines for the installation of direct expansion cooling coils have been provided to insure proper performance and longevity of the coils. These are general guidelines that may have to be tailored to meet the specific requirements of any one job. As always, a qualified party or individual should perform the installation and maintenance of any coil. Protective equipment such as safety glasses, steel toe boots and gloves are recommended during the installation and maintenance of the coil.

IMPORTANT!

All field brazing and welding should be performed using high quality materials and an inert gas purge (such as nitrogen) to reduce oxidation of the internal surface of the coil.

IMPORTANT!

All field piping must be self supporting and flexible enough to allow for the thermal expansion of the coil.

Step 1 Locate the Distributor(s) by Removing the Distributor Access Panel



Distributor Access Panel

Hot Gas Bypass

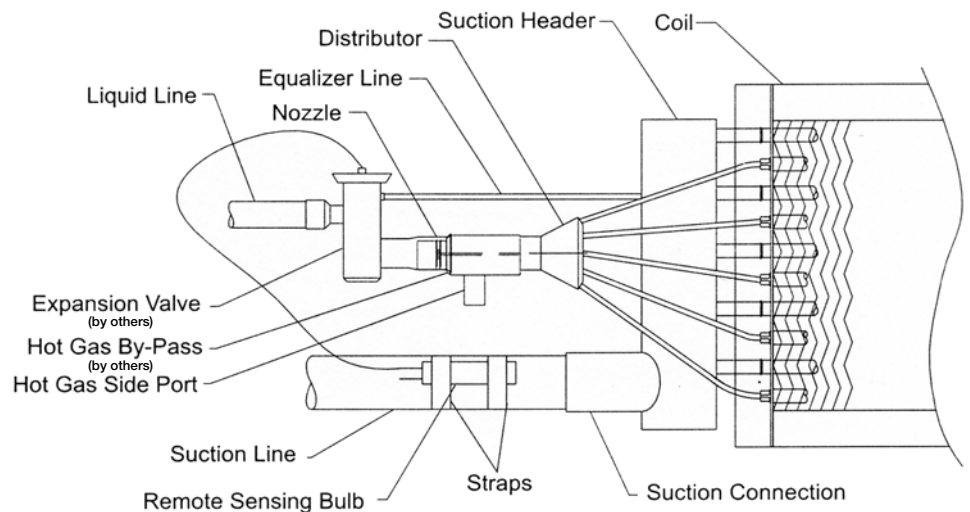

Installation with Hot Gas Bypass

Step 2 Verify Nozzle Placement

Inspect the refrigerant distributor and verify that the nozzle is in place. The nozzle is generally held in place by a retaining ring or is an integral part of the distributor itself.

NOTE!

If a hot gas bypass kit was provided by others, refer to the manufacturer's instructions

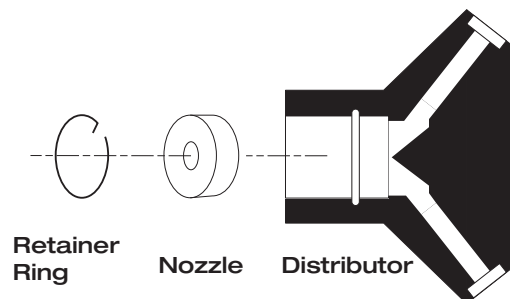

Nozzle Placement

Step 3 Install Suction Line

Install suction line(s) from the compressor to the suction connection(s) which are stubbed through the side of the cabinet.

Installation - Direct Expansion (DX) Coil Piping (Optional)

Step 4 Install the Liquid Line and Thermal Expansion Valve (TEV) (By Others)

Liquid line openings vary by coil size and circuiting and are field supplied. Follow the TEV recommendations for installation to avoid damaging the valve. If the valve is externally equalized, use a tubing cutter to cut off the plugged end of the factory installed equalizer line. Use a de-burring tool to remove any loose metal from the equalizer line and attach it to the TEV. If the valve is internally equalized, the factory installed equalizer line can be left as is.

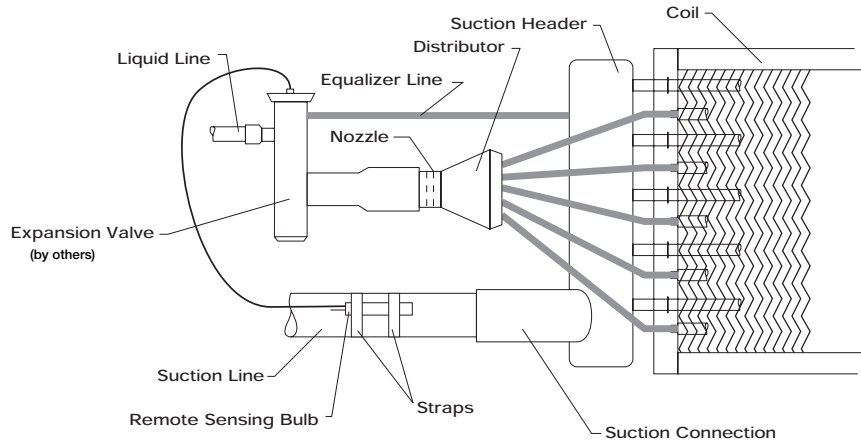

General Installation

Step 5 Mount the Remote Sensing Bulb (By Others)

The expansion valve's remote sensing bulb should be securely strapped to the horizontal run of the suction line at the 3 or 9 o'clock position and insulated.

Step 6 Check Coil Piping for Leaks

Pressurize the coil to 100 psig with dry nitrogen or other suitable gas. The coil should be left pressurized for a minimum of 10 minutes. If the coil holds the pressure, the hook-up can be considered leak free. If the pressure drops by 5 psig or less, re-pressurize the coil and wait another 10 minutes. If the pressure drops again there is likely one or more small leaks which should be located and repaired. Pressure losses greater than 5 psig indicate a large leak that should be isolated and repaired.

Step 7 Evacuate and Charge the Coil

Use a vacuum pump to evacuate the coil and any interconnecting piping that has been open to the atmosphere. Measure the vacuum in the piping using a micron gauge located as far from the pump as possible. Evacuate the coil to 500 microns or less then close the valve between the pump and the system. If the vacuum holds to 500 microns or less for one minute, the system is ready to be charged or refrigerant in another portion of the system can be opened to the coil. A steady rise in microns would indicate that moisture is still present and that the coil should be further vacuumed until the moisture has been removed.

NOTE!

Failure to obtain a high vacuum indicates a great deal of moisture or a small leak. Break the vacuum with a charge of dry nitrogen or other suitable gas and recheck for leaks. If no leaks are found, continue vacuuming the coil until the desired vacuum is reached.

Step 8 Install the Drain Line

Connect an unobstructed drain line to the drain pan. A trap should be used to prevent sewer gas from being drawn into the unit.

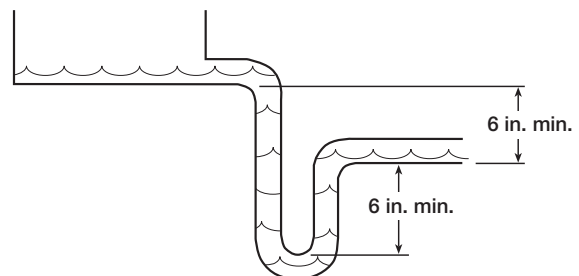

Drain Trap

IMPORTANT!

All traps must be installed below the roofline or be otherwise protected from freezing.

Installation - Chilled Water Coil Piping (Optional)

IMPORTANT!

Guidelines for the installation of the cooling coil have been provided to insure proper performance of the coils and their longevity. These are general guidelines that may have to be tailored to meet the specific requirements of any one job. As always, a qualified party or individual should perform the installation and maintenance of the coil. Protective equipment such as safety glasses, steel toe boots and gloves are recommended during the installation and maintenance of the coil.

IMPORTANT!

When installing couplings, do not apply undue stress to the connection. Use a backup pipe wrench to avoid breaking the weld between the coil connection and the header.

IMPORTANT!

All field piping must be self supporting. System piping should be flexible enough to allow for the thermal expansion and contraction of the coil.

Installation

Step 1 Verify Coil Hand Designation

Check the coil hand designation to insure that it matches the system. Coils are generally plumbed with the supply connection located on the bottom of the leaving air side of the coil and the return connection at the top of the entering air side of the coil. This arrangement provides a counter flow heat exchanger and positive coil drainage.

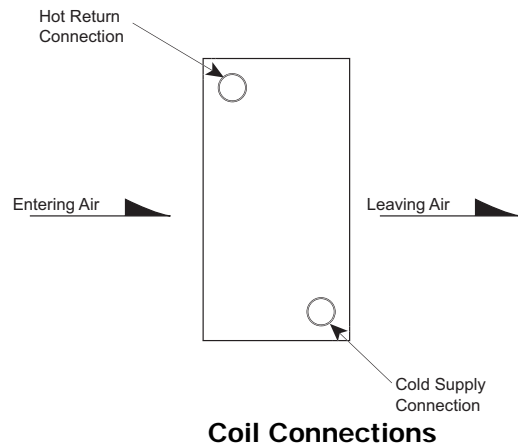

Step 2 Check the Coil for Leaks

Pressurize the coil to 100 psig with dry nitrogen or other suitable gas. The coil should be left pressurized for a minimum of 10 minutes. If the coil holds the pressure, the hook-up can be considered leak free. If the pressure drops by 5 psig or less, re-pressurize the coil and wait another 10 minutes. If the pressure drops again there is likely one or more small leaks which should be located and repaired. Pressure losses greater than 5 psig indicate a large leak that should be isolated and repaired.

Step 3 Connect the Supply and Return Lines

Connect the supply and return lines.

Step 4 Install the Drain Line

Connect an unobstructed drain line to the drain pan. A trap should be installed to prevent sewer gas from being drawn into the unit.

IMPORTANT!

All traps must be installed below the roofline or be otherwise protected from freezing.

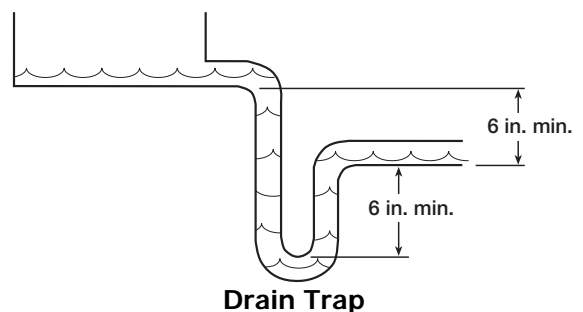

Installation - Building Pressure Control (Optional)

Step 1 Mount Pressure Tap

Using the factory provided bracket, mount the pressure tap to the outside of the unit. Choose a location out of the prevailing winds and away from supply or exhaust fans to assure accurate readings.



Pressure Tap

Step 2 Run Pressure Tap Lines

A pressure tap line must be run from the pressure tap mounted on the outside of the unit to the low pressure tap on the back of the pressure gauge. A second pressure tap line must be run from the high pressure tap on the back of the photohelic to the space. The high pressure line must be run even if the photohelic is mounted in the space. Fifty feet of tubing is supplied with the unit.

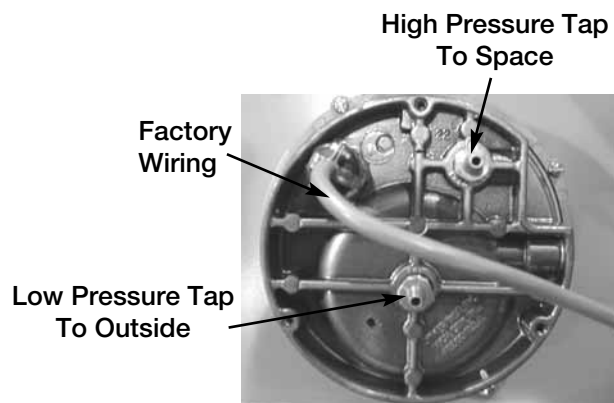

Back of Pressure Gauge

Pressure Tap Connection

Step 3 Set the Building Pressure

The pressure gauge is used to set the desired building pressure. The pressure is set by adjusting the knobs for the upper and lower pressure limits. Typical settings are 0.0 in. wc for the lower and 0.10 in. wc for the upper pressure setting.

Step 4 Check Control System

NOTE!

Blower Start-Up, steps 1-4 should be performed before the blower is run.

Before the unit is left in service, the building pressurization control system should be tested. This can be accomplished by turning both knobs to the upper most pressure setting. You may have to remove the outdoor pressure tap tubing. The return air damper should close (VAV systems should go to max speed). Then set both knobs at the lowest setting, and the damper should open (VAV systems should go to minimum speed). It may take one to two minutes for the VFD/damper to reach the desired position. Reset the correct pressure limits before starting the unit. The picture on the bottom right shows a typical photohelic setting. The needle in this photo indicates a negative building pressure. During correct operation the indicating needle will remain between or near the setting needles.

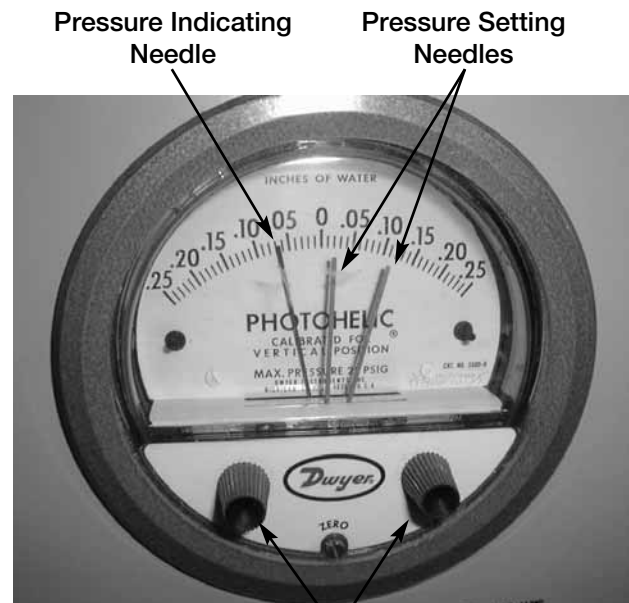

Pressure Setting Knobs on Pressure Gauge

Building Pressure Settings

Start-Up - Blower

REFER TO THE START-UP CHECKLIST IN THE REFERENCE SECTION BEFORE PROCEEDING FURTHER!

Pre-Start-Up Check

Rotate the fan wheel by hand and make sure no parts are rubbing. Check the V-belt drive for proper alignment and tension (a guide for proper belt tension and alignment is provided in the belt maintenance section). Check fasteners, set screws and locking collars on the fan, bearings, drive, motor base and accessories for tightness. Remove any shipping fasteners from the blower vibration isolators.

WARNING!
Disconnect and lock-out all power and gas before performing any maintenance or service to the unit. Failure to do so could result in serious injury or death and damage to equipment.

SPECIAL EQUIPMENT REQUIRED

Below is a list of special tools that are required. A recommended model is shown, but equivalent products may be used.

Description	Manufacturer-Model	Phone	Website
Voltage Meter	Fluke-179	1-800-44-FLUKE	www.fluke.com
Amperage Meter	Fluke-179	1-800-44-FLUKE	www.fluke.com
Thermometer	Fluke-50	1-800-44-FLUKE	www.fluke.com
Micro Amp Meter	Fluke-16	1-800-44-FLUKE	www.fluke.com
U-Tube manometer	Dwyer-Slack Tube	1-219-897-8000	www.dwyer-inst.com
Tachometer	Monarch-Pocket Tach 100	1-800-999-3390	www.monarchinstruments.com

WARNING!

Check the housing, blower, weatherhood, filter section and ductwork for foreign objects and debris before the blower is run.

Step 1 Check the Voltage

Before starting the unit, compare the supplied voltage, hertz, and phase with the unit and motor's nameplate information. The nameplate is located on the outside of the unit on the control panel side.

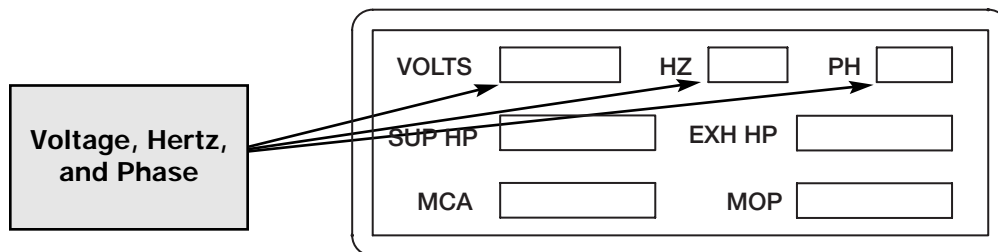

Electrical Nameplate

Step 2 Check the Blower Rotation

Open the blower access door and run the blower momentarily to determine the rotation. Arrows are placed on the blower scroll to indicate the proper direction or reference the example below.

NOTE!

To reverse the rotation on three phase units, disconnect and lock-out the power, then interchange any two power leads.

NOTE!

To reverse the rotation on single phase units, disconnect and lock-out the power, then rewire the motor per the manufacturer's instructions.

IMPORTANT!

If the blower is rotating in the wrong direction, the unit will move some air, but will not perform as designed. Be sure to perform a visual inspection to guarantee the correct blower rotation.

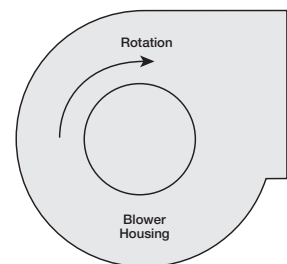

Blower Rotation

Start-Up

Start-Up - Blower

Step 3 Check for Vibration

Check for unusual noise, vibration or overheating of the bearings. Reference the troubleshooting section for corrective actions.

IMPORTANT!

Excessive vibration may be experienced during the initial start-up. Left unchecked, it can cause a multitude of problems including structural and/or component failure.

IMPORTANT!

Generally, fan vibration and noise is transmitted to other parts of the building by the ductwork. To minimize this undesirable effect, the use of heavy canvas duct connectors is recommended.

Step 4 Motor Check

Measure the motor's voltage, amps and RPM. Compare to the specifications. Motor amps can be reduced by lowering the motor RPM or increasing system static pressure.

NOTE!

Additional starters and overloads may be provided in the make-up air control center for optional exhaust blowers. Any additional overloads must be checked for proper voltage, amps and RPM's.

Start-Up

Step 5 Air Volume Measurement and Check

Measure the unit's air volume (CFM) and compare it with its rated air volume. If the air volume is off, adjust the fan's RPMs by changing the drive.

NOTE!

The most accurate way to measure the air volume is by using a pitot traverse method downstream of the blower. Other methods can be used but should be proven and accurate.

IMPORTANT!

Changing the air volume can significantly increase the motor's amps. If the air volume is changed, the motor's amps must be checked to prevent overloading the motor.

NOTE!

To ensure accuracy, the dampers are to be open when measuring the air volume.

Step 6 Set-up Optional Components

Adjust the settings on the optional components. See the control center layout in the Reference section for location of optional components.

- Heating Inlet Air Sensor (typical setting: 60-70°F)
- Cooling Inlet Air Sensor (typical setting: 75°F)
- Building Freeze Protection (typical setting: 5 min at 45°F)
- Dirty Filter Gauge (typical setting: settings vary greatly for each unit). (see Reference section for adjusting information)
- Solid Fuel Time Delay (typical setting varies per application)

Start-Up - Direct Gas

IMPORTANT!

For proper unit function and safety, follow the start-up procedure in the exact order that it is presented.

IMPORTANT!

This start-up should begin after all of the installation procedures and the Blower start-up have been completed.

Step 1 Check the Supply Gas Pressure

Check the supply gas pressure and compare it with the unit's nameplate pressure requirements. Adjust the supply regulator as needed until the supply gas pressure is within the specified range. See figure #40. The nameplate is located on the outside of the unit on the control panel side.

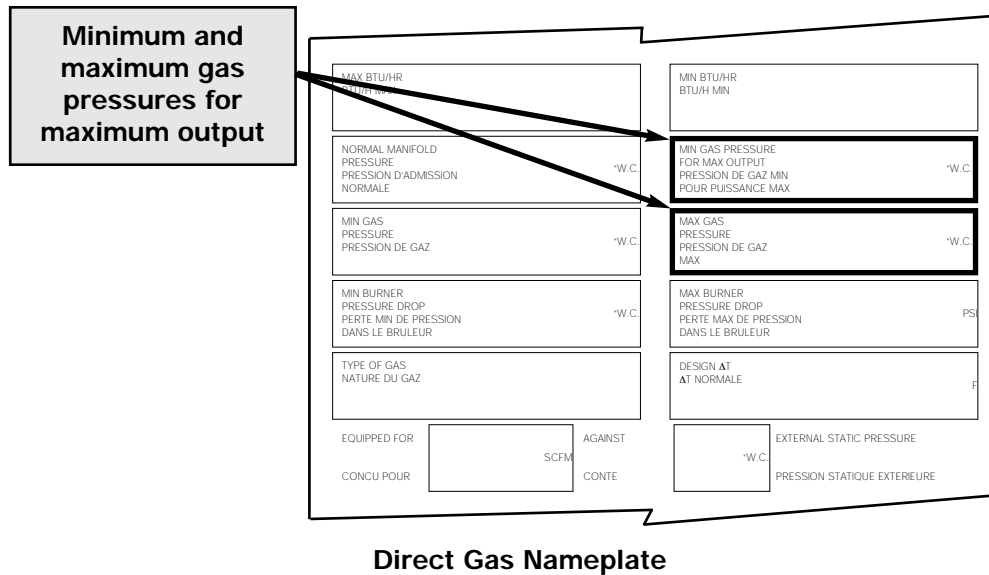

Start-Up

Step 2 Check the Optional High and Low Gas Pressure Switches

Check the settings on the high and low gas pressure switches. The high pressure setting is typically 8 inches wc and the low pressure setting is typically 3 inches wc. The switches are set at the factory and should not need adjustment. Adjust the setting only if needed. See the gas train layout diagram in the reference section for the high and low pressure switch location.

NOTE!

The purpose of the high and low gas pressure switches is to automatically shut down the burner if the inlet gas pressure is too low for the burner to safely light, or if the manifold pressure is too high for the burner to operate properly.

Start-Up - Direct Gas

IMPORTANT!

Proper air velocity over the burner is critical on direct fired gas units. If the air velocity is not within the unit specifications, the unit will not operate efficiently, may have sporadic shutdowns and may produce excessive carbon monoxide (CO) or other gases.

Step 3 Set the Burner Air Pressure Differential

With all access panels in place, the fan running and discharging 70°F air, connect a U-Tube manometer to the outer sensing probes (see below) and measure the static pressure across the burner.

The proper static pressure should be between 0.625 and 0.675 inches wc. If needed, evenly adjust the baffles above and below the burner, keeping the burner centered in the opening until the required pressure is obtained.

NOTE!

The pressure drop was set at the factory and may not need adjustment.

NOTE!

When required pressure is obtained be sure to reconnect the outer sensing probes.

IMPORTANT!

This process may need to be repeated until the proper pressure is achieved. This adjustment will change the air quantity delivered by the unit and therefore the air quantity delivered should be rechecked. Refer to the blower start-up section.

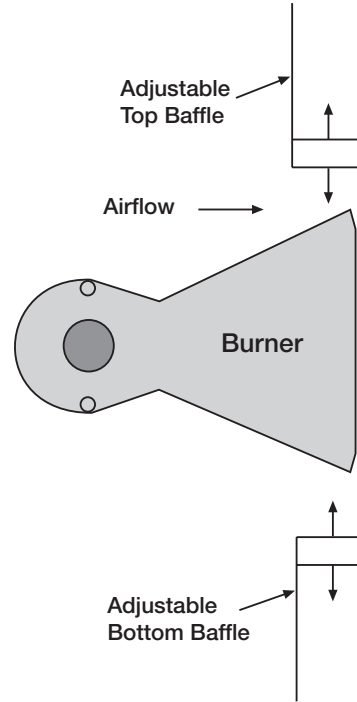

Burner and Baffles

NOTE!

To increase the static pressure decrease the opening. To decrease the static pressure increase the opening.

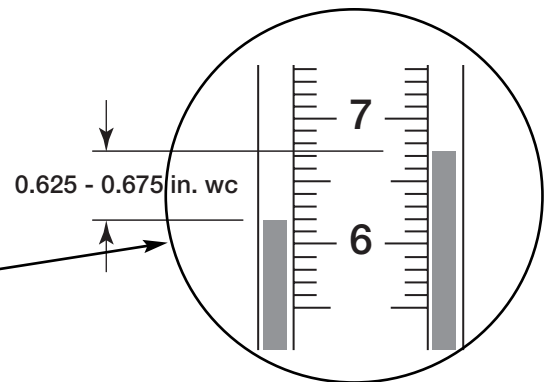
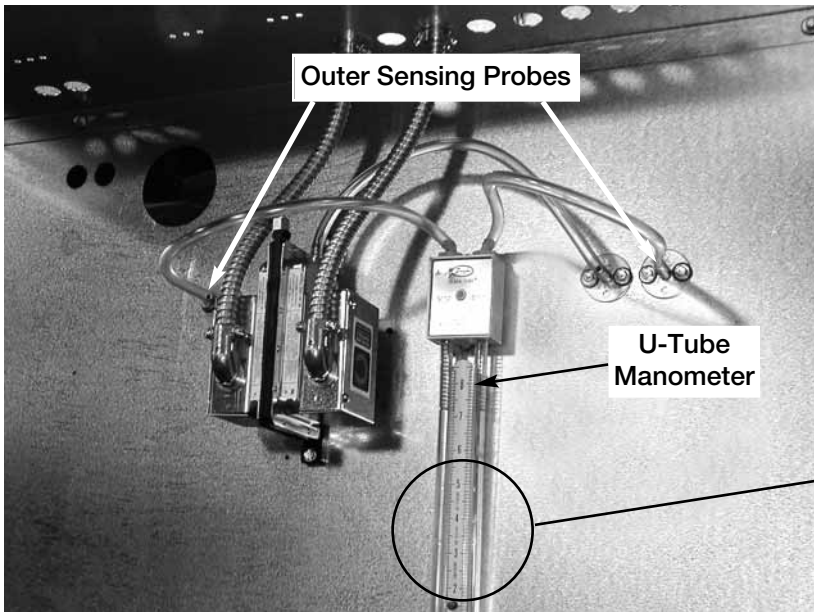

Measuring the Burner Pressure Drop

Start-Up

Start-Up - Direct Gas

Step 4 Set the Low Fire Time Delay

Set the low fire time delay to 75% of its maximum setting. See below for the location of the time delay setting.

NOTE!

The low fire time delay must be set high enough to provide at least 10 seconds of low fire while the unit tries to light.

Step 5 Set the Maximum Firing Rate

Monitor the unit's actual temperature rise by placing a thermocouple in the unit's inlet and a second in the discharge, three duct diameters downstream of the burner.

Send the unit to maximum fire by disconnecting and isolating the proper wire on the Maxitrol amplifier (Terminal #4 for Maxitrol 14, #3 for Maxitrol 44 as shown in figure below).

Continues on next page...

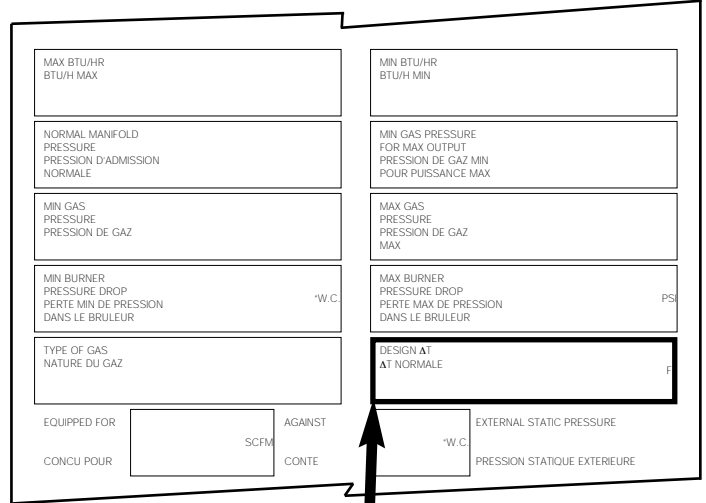

WARNING!

Do not set the burner maximum firing rate based on gas pressure. It should be set based on the unit's designed temperature rise shown on the direct gas label.

Start-Up

Direct Gas Nameplate

Maxitrol Series 14

(7 terminals)

Remove the wire from terminal #4 to send the unit to maximum fire



Low fire time delay setting (75% of maximum)

Maxitrol Series 44

(9 terminals)

Remove the wire from the #3 terminal to send the unit to maximum fire

Minimum discharge temperature setting (50°F Typical)



Low fire time delay setting (75% of maximum)

Maximum discharge temperature setting (100°F Typical)

Start-Up - Direct Gas

Step 5 Set the Maximum Firing Rate (...continued)

While monitoring the units temperature rise, set the maximum firing rate by adjusting the regulator until the designed temperature rise is achieved. After setting the maximum firing rate, reconnect the wire to the amplifier.

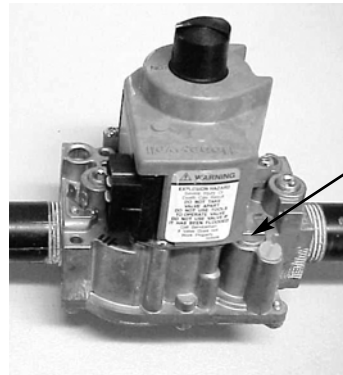

Maximum firing rate adjustment

Regulator

IMPORTANT!

Setting the maximum firing rate during mild weather conditions may cause the high limit to trip out during extreme conditions requiring manual resetting.

NOTE!

Clockwise rotation increases the temperature rise, counterclockwise rotation decreases the temperature rise.

NOTE!

The minimum setting for the maximum firing rate may be higher than required. This is acceptable, the burner will modulate as needed.

Step 6 Set the Minimum Firing Rate

Disconnect and isolate one of the wires running to the modulating valve to send the unit to its minimum firing rate. Set the minimum firing rate by adjusting the needle valve shown below.

After setting the minimum firing rate, reconnect the wire to the modulating valve.

IMPORTANT!

The proper minimum firing rate setting results in a small ribbon of continuous flame which covers the flame rod and runs across the entire burner.

IMPORTANT!

The minimum firing rate setting is critical. If the settings is too high, the unit may not light, too low and the flame rod may not detect the flame.

IMPORTANT!

Do not allow the disconnected wire to come in contact with a potential ground, damage to the amplifier or transformer could result.

Remove one wire to send the unit to the minimum firing rate.

NOTE!

Adjusting the maximum and minimum fire may require the inlet air sensor to be initially set higher than desired in order to start the burner(s). Once high and low fire have been set, the inlet air sensor should be turned down to the desired temperature.

Minimum firing rate adjustment



Modulating Valve

NOTE!

Counterclockwise rotation increases the minimum fire rate setting, clockwise rotation decreases the setting.

Start-Up - Direct Gas

Step 7 Set the Unit's Operating Temperature

Set the operating temperature. The operating temperature setting depends on which Maxitrol controller is used.

Maxitrol Series 14

IMPORTANT!

The Maxitrol Series 14 should be set to the desired discharge temperature. The temperature selector may be built into the amplifier or may be a stand-alone dial. The stand-alone dial may be mounted remotely.

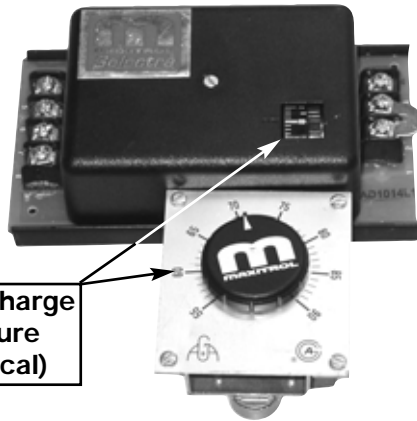

Set the discharge temperature (65°F Typical)

Series 14 Discharge Temperature Setting

Maxitrol Series 44

IMPORTANT!

The Maxitrol Series 44 should be set to the desired temperature. If the Maxitrol 44 is provided with the space temperature control option, the Selectra Stat must be mounted in the space being heated.

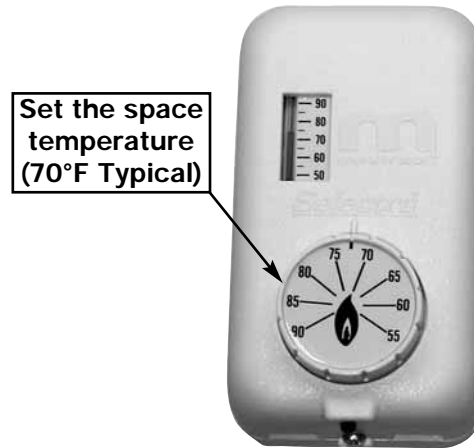

Set the space temperature (70°F Typical)

Series 44 Temperature Setting (shown as Space Temperature Control)

Start-Up

Step 8 Flame Signal Check

To measure the flame signal connect a micro amp meter to terminals (FC+) and (FC-) on the Fenwal flame safe guard. The flame signal should be above 1.0 micro amp and steady.

Check the flame signal with the burner at minimum fire, mid-fire and high-fire.

NOTE!

If the flame signal is not above 1.0 micro amp and steady, consult the troubleshooting section.

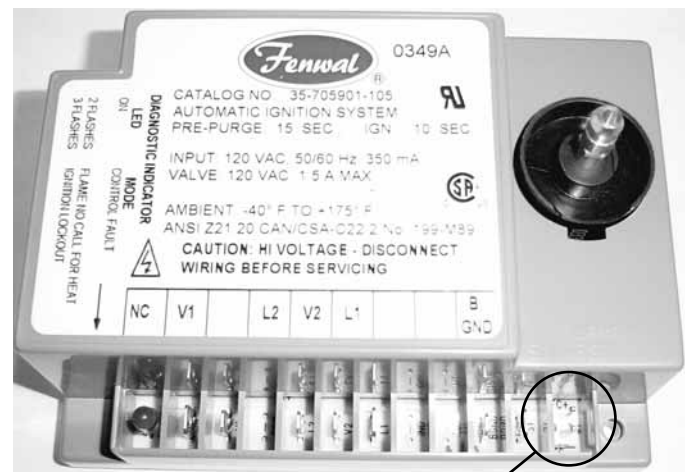

FC+

FC-

Flame Safe Guard

Start-Up - Evaporative Cooling Recirculating (Optional)

Step 1 Check the Installation

The media may have been removed during installation, so its orientation should be double checked. The media should be installed with the steeper flute angle sloping down toward the entering air side.

Verify that the stainless steel caps and distribution headers are in place. The headers should be located over the media towards the entering air side. The caps should be placed over the headers.

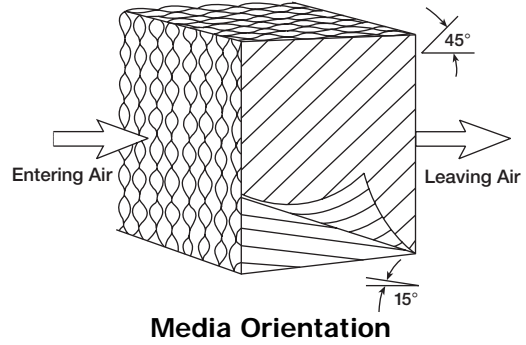

Step 2 Check the Pump Filter

Check that the pump filter is around the pump inlet.

Step 3 Fill the Sump and Adjust the Float

Turn on the water supply and allow the pan to fill. Adjust the float valve to shut-off the water supply when the sump is filled to within 1 in. of the bottom of the overflow. See below.

Step 4 Break-in the Media

Open the bleed-off valve completely and saturate the media with the blower(s) off for no less than 20 minutes.

Step 5 Check the Flow Rate

The pumps should provide enough water to saturate the media in 45 to 60 seconds. Consult the factory, if adequate flow is not achieved.

Step 6 Adjust the Water Bleed-Off Rate

The water bleed-off rate is dependent on the water's mineral content. The bleed-off should be adjusted based on the media's mineral deposits after two weeks of service.

Step 7 Set the Optional Auto Drain and Fill

Set the auto drain and fill timer and temperature settings. Timer settings are t1: 1.0, 10min and t2: 0.4, 60h. Temperature is typically set to 45°F.

Step 8 Put the Unit into Service

Remove the jumper, and energize the blower(s). Verify proper operation.

NOTE!

A jumper will need to be installed in the control center to power the evaporative pumps with the blower(s) off. Reference the unit's ladder diagram to determine proper terminals.

Start-Up

IMPORTANT!
Check the media for minerals after two weeks of service and adjust the bleed-off rate accordingly.

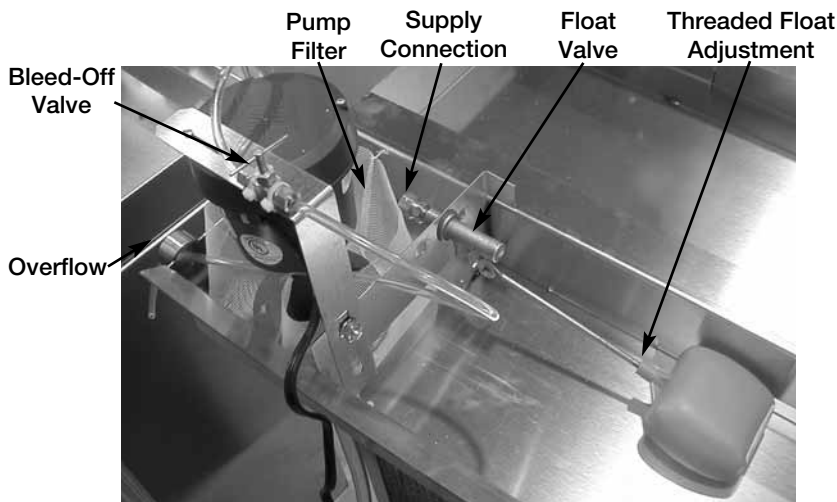

Evaporative Cooler Set-Up

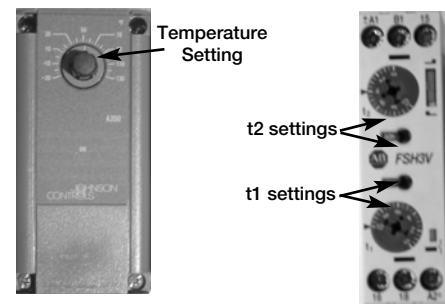

Evaporative Freeze Protection

Evaporative Timer

Start-Up - Water Wizard (Optional)

Step 1 Open the Solenoid

 Confirm that the manual water supply valve is closed. Press and hold the Function Button for one second. L3 will begin blinking (short on, long off), indicating that Flow Test Mode is active and the supply solenoid is open.

Step 2 Set the Water Pressure

 With the solenoid open, set the supply water pressure to the correct setting. (see table at right). Use the manual supply valve to adjust the supply pressure. A pressure gauge is provided between the manual supply valve and the media.

Housing Size	Media Width (inches)	Water Pressure (in. wc)
12	30	20
22	43 $\frac{3}{4}$ *	36
	60*	61
32	66*	72
	96*	42
DG-10	26 $\frac{3}{4}$	19
DG-20	66	74
DG-30	84*	35

*Multiple media sections. Value represents total media width.

Recommended Water Pressure Chart

NOTE!

The manual supply valve ships closed and must be adjusted for proper performance.

Step 3 Close Solenoid

 With the pressure set, press the Function Key for one second to deactivate Flow Test Mode and allow the supply solenoid to close.

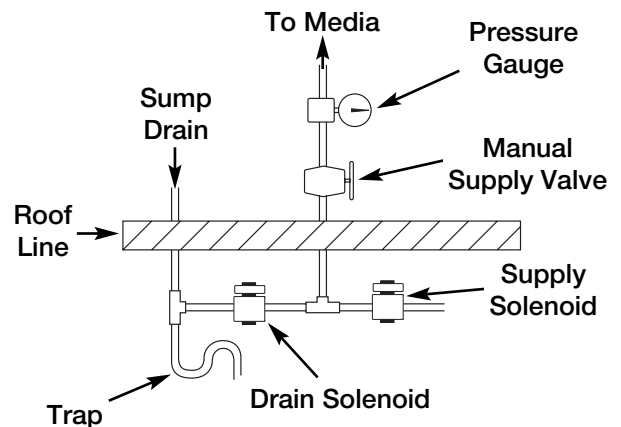

Water Wizard Installation

Step 4 Check Media

Start the cooling cycle and check the media after one hour of operation. If the media is continuously dry or if too much water is draining from the sump tank, refer to Troubleshooting, Water Wizard.

NOTE!

The inlet air sensor function overrides and shuts down the evaporative cooler if the outside temperature falls below the minimum cooling temperature.

NOTE!

The minimum cooling temperature is preset to the factory recommended 75°F. Steps 5-7 should only be complete if the minimum cooling temperature needs adjustment.

Step 5 Enter Program Mode

 Press and hold the Enter Key for three seconds. The display will read "Pro" when Program Mode is active.

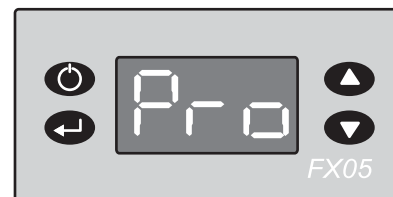

Program Display

Start-Up

Start-Up - Water Wizard (Optional)

Step 6 Adjust the Minimum Cooling Temperature

- ▲ While in the Program Menu, use the Up and Down Keys to navigate the Menu Options until “toF” is displayed. Press the Enter Key to access the selected Menu Option setting.
- ▼
- ↵ Use the Up and Down Keys to adjust the Minimum Cooling Temperature as needed. Press the Enter Key to save the Minimum Cooling Temperature setting and return to the Program Menu.

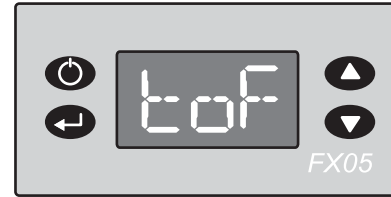

Minimum Cooling Temperature Display

IMPORTANT!
The Enter Key must be pressed to save the new Minimum Cooling Temperature.

Step 7 Exit Program Mode

After ten seconds of idle time the controller will exit Program Mode.

Start-Up

NOTE!

The Freeze Temperature is preset to the factory recommended 41°F. Steps 8-10 should only be completed if the Freeze Temperature needs adjustment.

NOTE!

The Freeze Temperature is the temperature at which the supply solenoid closes and the drain solenoid opens to drain the supply line, preventing possible freeze damage. A drain solenoid is required for this option.

Step 8 Enter Program Mode

- ↵ Press and hold the Enter Key for three seconds. The display will read “Pro” when Program Mode is active.

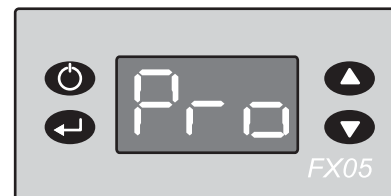

Program Display

Step 9 Adjust the Freeze Temperature

- ▲ While in Program Mode, use the Up and Down Keys to navigate through the Menu Options until “Frt” is displayed. Press the Enter Key to access the selected Menu Option setting.
- ▼
- ↵ Use the Up and Down Keys to adjust the Freeze Temperature setting as needed. Press the Enter Key to set the Freeze Temperature and return to the Program Menu.



Freeze Temperature Display

IMPORTANT!

The Enter Key must be pressed to save the new Freeze Temperature .

Step 10 Exit Program Mode

After ten seconds of idle time the controller will exit Program Mode.

Operation - VAV / Recirculating Units

Variable Volume Operation (Optional)

The variable volume option is recommended when a building's exhaust volume may vary. This option enables the make-up air volume to track with the exhaust volume, providing only the amount of make-up air required. Control strategies include 2-speed and modulating blowers.

2-Speed

- A 2-speed motor is used to control air volumes. The motor can be switched to low or high speed from a remote control panel.

Modulating

- Potentiometer Control - a variable frequency drive is controlled by input from a remote speed selector (potentiometer). This unit allows easy manual adjustment of make-up air volumes.
- Building Pressure Control - a variable frequency drive is controlled according to input from a pressure sensing device.
- External Signal - a variable frequency drive is controlled according to input from an external 2-10 VDC or 4-20 mA signal (by others).

Variable Frequency Drives

For maintenance issues associated with the variable frequency drives, please consult the drive's manual supplied with the unit. The drives are programmed in the factory and should not need any adjustment during installation and start-up. For kitchen applications, the drive may be located in the kitchen, not in the unit.

Burner Bypass Damper (Optional)

The self-adjusting burner bypass damper is a device used in variable volume units. Its function is to maintain proper combustion by providing a constant airflow over the burner when outside air volumes are changed. It is located underneath the burner as shown in the picture below.

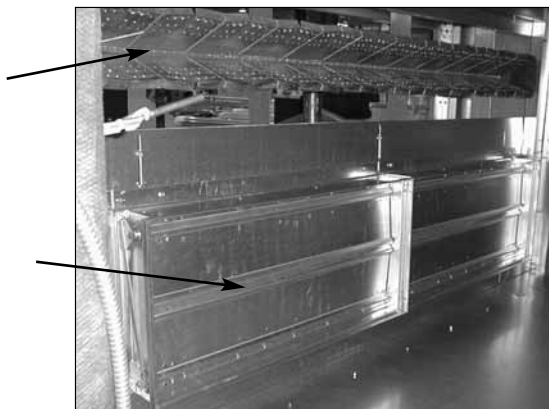

Burner Bypass Damper

WARNING!

The burner bypass damper is set-up at the factory. The weights and springs should not be adjusted in the field. The damper may not fully close during minimum outside air mode.

Operation - VAV / Recirculating Units

Recirculation Operation (Optional)

The recirculation operation option is recommended when the ventilation equipment provides the primary source of heating for the space. A minimum of 20% outdoor air is mixed with up to 80% filtered recirculated air. Control strategies include 2-position and modulating dampers.

2-Position Damper

- A 2-position spring return actuator is used to control the return air amounts. The damper moves from open to closed. If power is cut to the unit, the outdoor air damper will fail close.

Modulating

- Potentiometer Control - a modulating spring return actuator is used to control the return air amounts. The return air damper modulates from fully open to fully closed based on a signal from a remote potentiometer.
- Building Pressure Control - a modulating spring return actuator is used to control the return air amounts. The return air damper modulates from fully open to fully closed based on a signal from a remote pressure sensing device.
- External Signal - a modulating spring return actuator is used to control the return air amounts. Return air damper modulates from fully open to fully closed based on an external 2-10 VDC or 4-20 mA signal (by others).

Operation - Electrical

Electrical Sequence

1. Exhaust Fan Contact (S1) Closed (Optional)

- Power passes to exhaust starter(s) ST2(3)
- N.O. exhaust starter switches are energized and closed
- Power passes to exhaust fans
- Exhaust fans start

2. Supply Fan Contact (S2) Closed

- N.O. contact(s) ST2(3) are closed
- Power passes to optional freeze protection relay (FZ1) and if temperature is acceptable N.C. contact (FZ1) remains closed
- Power passes to damper which opens
- When damper is fully opened, damper relay (D1) is energized and optional N.O. damper limit switch (DL1) closes.
- Power passes to and energizes supply starter relay (ST1)
- Supply starter contact (ST1) closes and power reaches and energizes supply fan
- Supply fan starts

3. Heat Contact (S4) Closed

- Power passes to N.O. fan relay which is energized and closed
- Power passes to optional inlet air sensor contact (TS) which is energized and closed if the inlet air temperature is below the set point
- Power passes to and energizes heat relay (RH)
- N.O. heat relay contact (RH) closes
- Power passes to N.C. high limit control contact (HLC) which is closed if temperature has remained below set point
- Power passes to optional N.O. and N.C. gas pressure contacts (PS) which are both closed if gas pressure is within the set range
- Power passes to N.O. and N.C. airflow switch (PS) which are closed if there is proper airflow across the burner
- Power passes to terminal L1 on the FSG which begins it's sequence (see direct gas sequence)

4. Evaporative Cooling Contact (S4) Closed*

- N.O. contact on fan relay is energized and closed
- Power passes to optional inlet air sensor contact (TS2) which is energized and closed if the inlet air temperature is above the set point
- Power passes to and energizes cool relay (R1)
- N.O. contact R1 is energized and closed
- Power passes to evaporative cooling pump (P1)

*If DX or chilled water coils are used rather than an evaporative cooler, the cooling sequence of operation will depend on the coil controls. Cooling coil controls are supplied by others.

Direct Gas Burner Sequence

1. Supply Fan Contact Closed

- Power passes to the supply fan and heat switch

2. Heat Contact Closed

- Power passes to the heat relay then to the Flame Safe Guard

3. Flame Safe Guard (FSG) Sequence

- Checks for proper airflow
- Verifies no flame present at burner
- Initiates 15 second prepurge
- Sends power to open gas valve (V2) and energizes the spark generator (clicking of the spark generator may be heard).
- Tries for up to 10 seconds to light and confirm flame.
- Shuts down spark generator
- Continuously monitors the flame and airflow

Operation - Water Wizard™

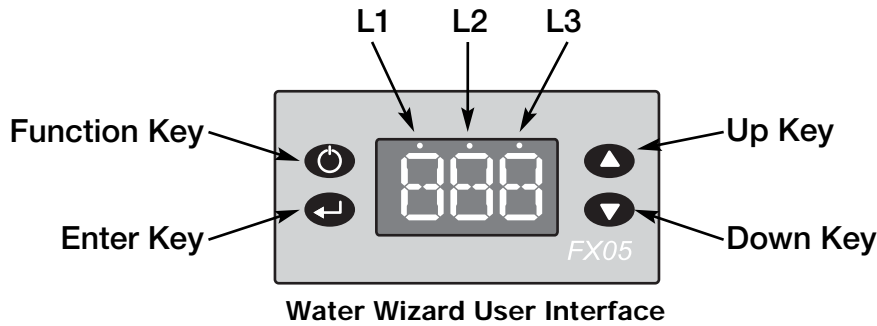

Key Function Descriptions

Drain Mode

Drain Mode locks open the drain solenoid and drains the supply line between the supply solenoid and the media. To activate Drain Mode simultaneously press the Function and Enter Keys. To deactivate Drain Mode and unlock the drain solenoid, simultaneously press the Function and Enter Keys again.

Flow Test Mode

Activating Flow Test Mode opens the supply solenoid and allows water to pass to the manual supply valve. To activate Flow Test Mode, press and hold the Function Key for one second. To deactivate Flow Test Mode and allow the supply solenoid to close, press and hold the Function Key again for one second.

CAUTION!

The sump drain line must be clear and draining to a safe location before using Flow Test Mode.

CAUTION!

Be aware of the water level in the sump tank at all times when using the Flow Test Mode.

Operation

Program Mode

Program Mode allows the user to view the Program Menu and edit the factory default settings. To access Program Mode and view the Program Menu press and hold the Enter Key for three seconds. While viewing the Program Menu press the Up and Down Keys to scroll through the Menu Options. To view the setting of the selected Menu Option press the Enter Key. To edit the setting, press the Up or Down Key while viewing the setting. To save the setting and return to the Program Menu press the Enter Key. To return to the Program Menu without saving the change, wait 10 seconds. To exit Program Mode from the Program Menu, wait 10 seconds.

WARNING!

Changing the default settings will significantly effect performance. Only change a setting after reading and understanding this entire manual.

NOTE!

The Enter Key must be pressed to save any changes made to a setting.

Dry Bulb Temperature

The default display is the Dry Bulb Temperature of the outside air.

Wet Bulb Temperature

To view the Wet Bulb Temperature, simultaneously press and hold the Up and Down Keys.

Indicating Lights

Three indicating lights are located across the top of the display to indicate the status of the Water Wizard.

LIGHT STATUS				
Indicating Light	On	Off	Blinking (Long on, Short Off)	Blinking (Short on, Long Off)
L1	Call for Cooling	No Call for Cooling	N/A	N/A
L2	Drain Solenoid Open	Drain Solenoid Closed	N/A	N/A
L3	Cooling On	Cooling Off	Supply Solenoid Locked Closed	Flow Test Mode Active

Troubleshooting

Blower Does Not Operate

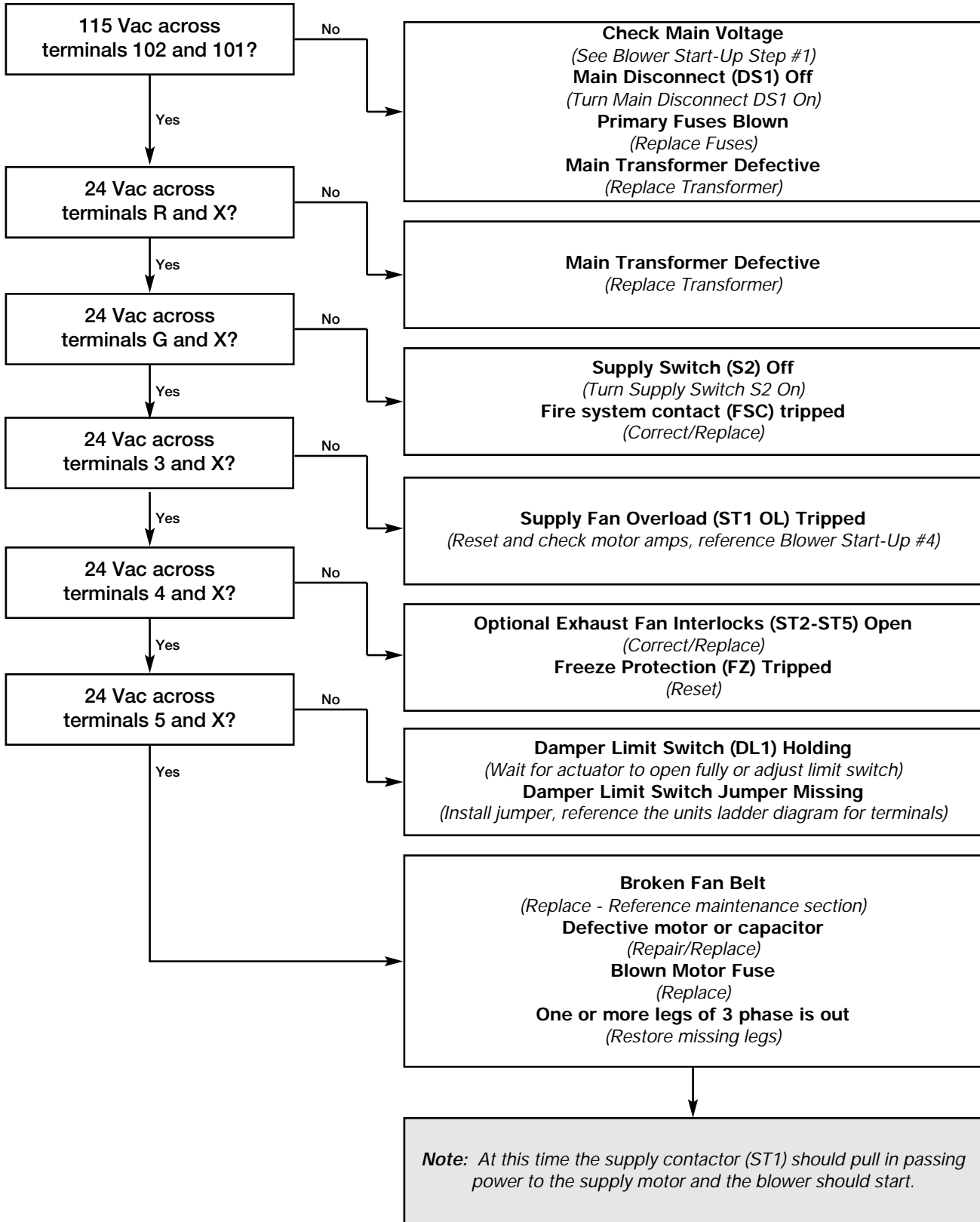

Troubleshooting

Troubleshooting

Heater Does Not Operate

Does not attempt to light (No visible spark)

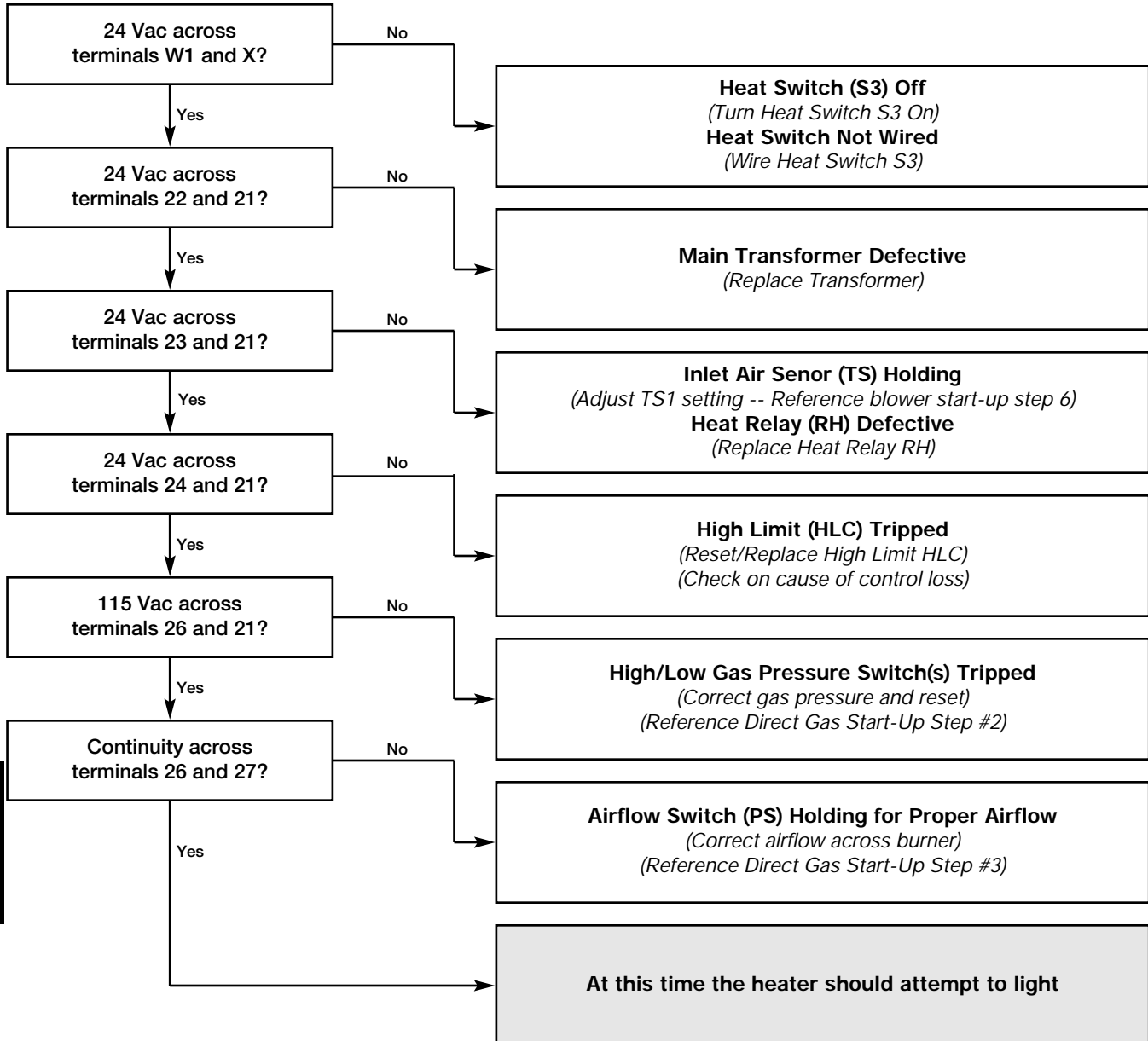

Troubleshooting

Heater Does Not Operate

Attempts to light but no flame (Visible spark)



Troubleshooting

Troubleshooting

Water Blows through Evaporative Cooler

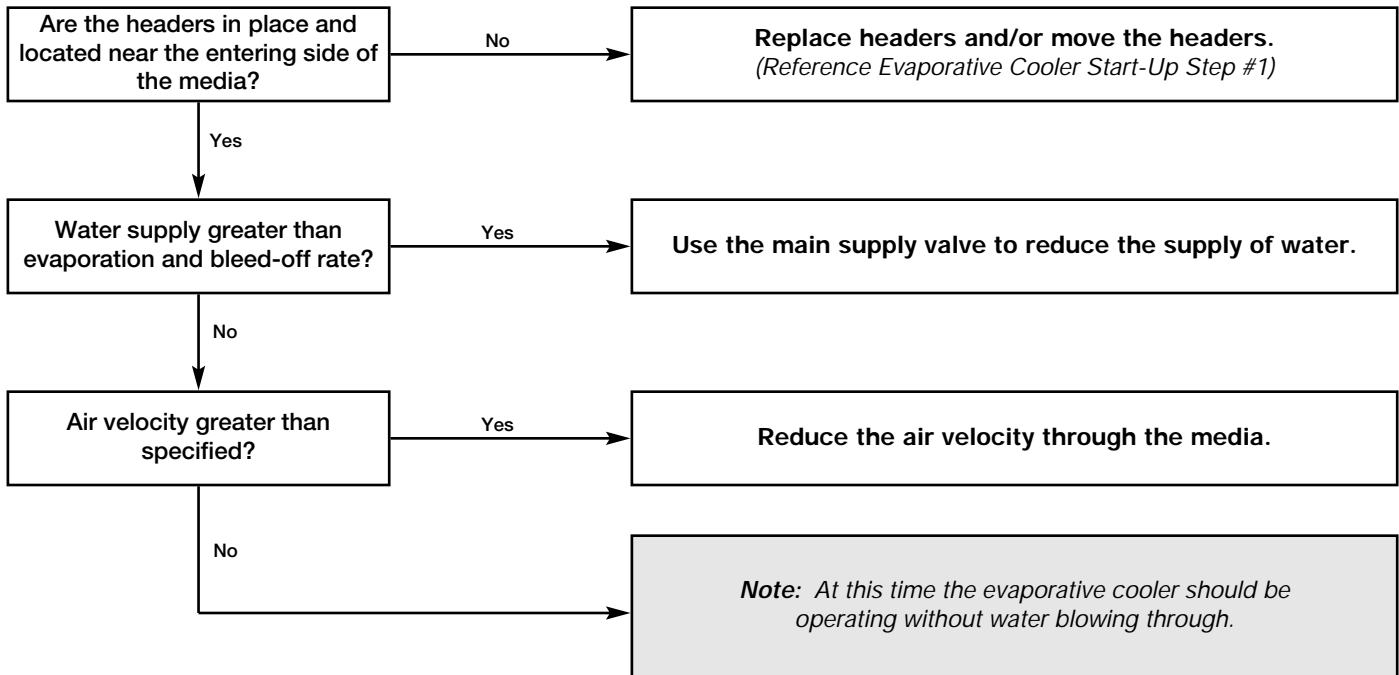

Troubleshooting

Water Wizard (Improper Water Supply)

NOTE!

If the water supply is too low, the media will continuously appear dry.

NOTE!

If the water supply is too high, the media will be saturated and excessive water will be draining from the sump tank.

NOTE!

Some water drainage is desired to keep the media flushed, but it should be minimized to utilize the Water Wizard.

Step 1 Adjust the Manual Supply Valve

Adjust the manual supply valve (refer to Start-Up, Water Wizard). If the recommended water pressure does not provide enough water, increase the pressure until the desired water supply is achieved. If the recommended water pressure provides too much water, decrease the water pressure until the desired water supply is achieved.

CAUTION!

Only proceed to steps two and three if step one does not correct the problem.

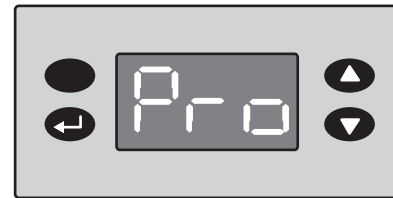

Step 2 Enter Program Mode

 Press and hold the enter key for three seconds to enter program mode. The display will read "Pro" when program mode is active.



Program Display

Step 3 Adjust the On Time Factor

-  While in the program menu, use the up and down keys to navigate through the menu options until "ont" is displayed.
-  With "ont" displayed, press the enter key to access the setting.

With the setting displayed, use the up and down keys to adjust the setting as needed.

Increase the factor to increase the water supply or decrease the factor to decrease the water supply.

Press the enter key to save the new on time factor and return to the program menu.



On Time Factor Display

NOTE!

Changing the on time factor by (1) will change the water supply by approximately 3%.

IMPORTANT!

The enter key must be pressed to save the new on time factor.

Step 4 Exit Program Mode

After ten seconds of idle time the controller will automatically exit program mode.

Troubleshooting

Excessive Noise or Vibration

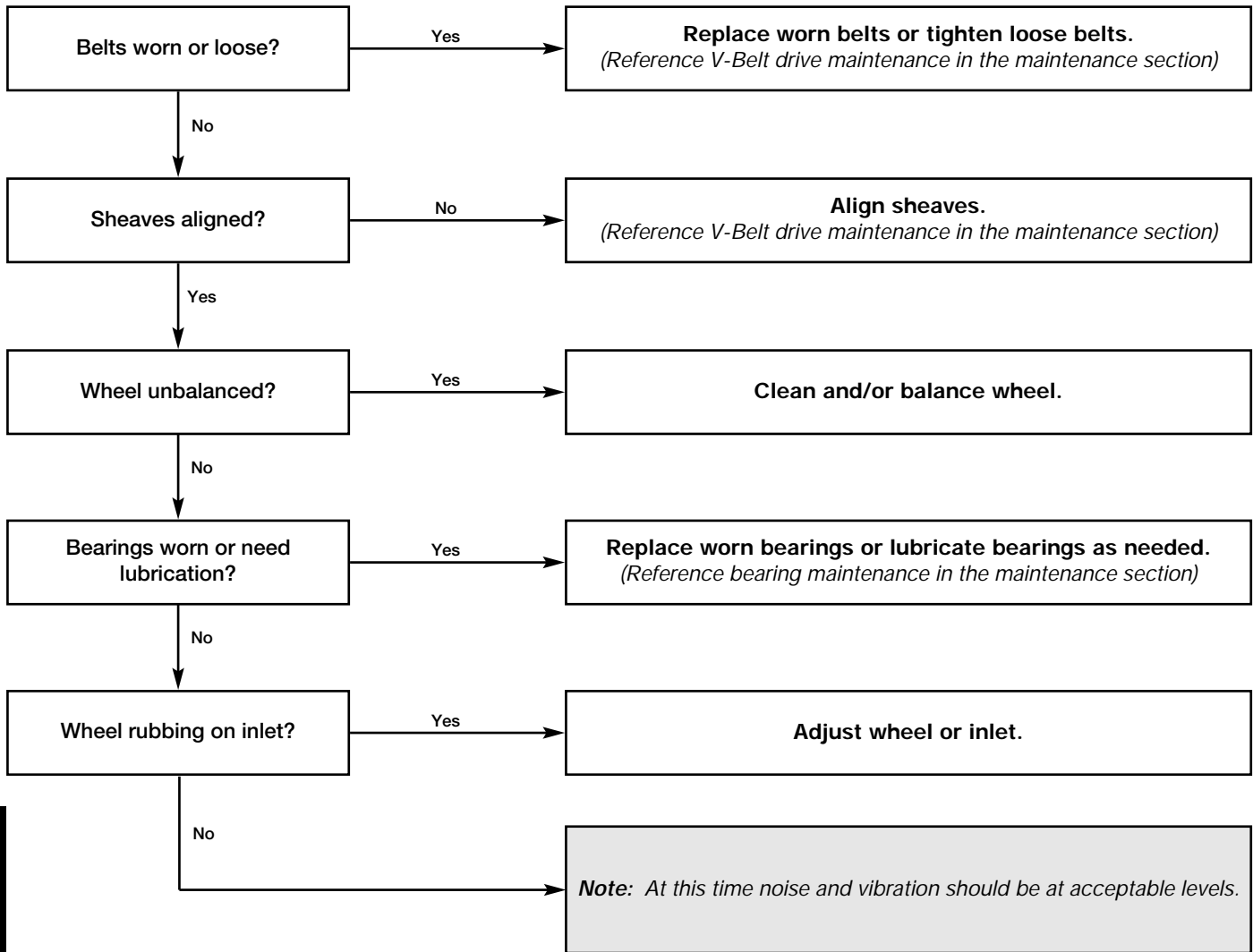

Maintenance - Routine

CAUTION!

Lock-out the gas and the electrical power to the unit before performing any maintenance or service operations to this unit.

V-Belt Drives

V-belt drives must be checked on a regular basis for wear, tension, alignment and dirt accumulation.

Check the tension by measuring the deflection in the belt as shown below.

Check the alignment by using a straight edge across both sheaves as shown below.

IMPORTANT!

Premature or frequent belt failures can be caused by improper belt tension, or misaligned sheaves.

Abnormally high belt tension or drive misalignment will cause excessive bearing loads and may result in failure of the fan and/or motor bearings.

Abnormally low belt tension will cause squealing on start-up, excessive belt flutter, slippage and overheated sheaves

IMPORTANT!

Do not pry belts on or off the sheave. Loosen belt tension until belts can be removed by simply lifting the belts off the sheaves.

IMPORTANT!

When replacing V-belts on multiple groove drives all belts should be changed to provide uniform drive loading.

IMPORTANT!

Do not install new belts on worn sheaves. If the sheaves have grooves worn in them, they must be replaced before new belts are installed.

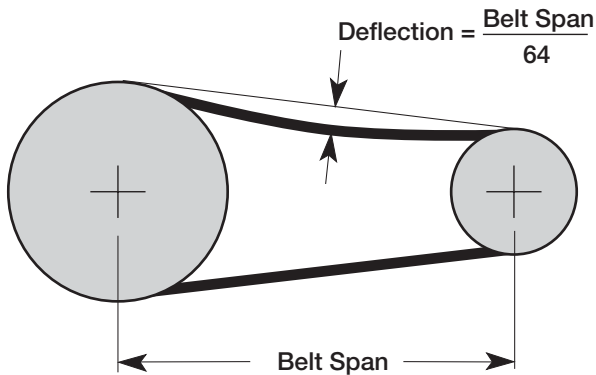

Belt Tension

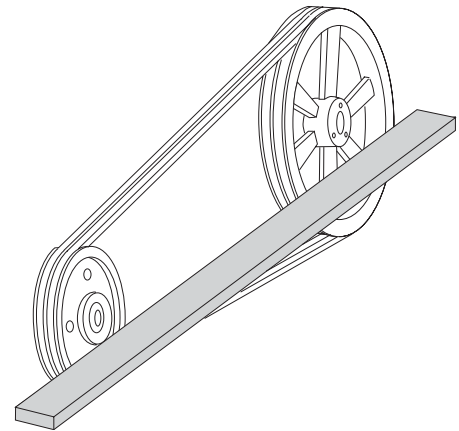

Drive Alignment

Maintenance - Routine

Motors

Motor maintenance is generally limited to cleaning and lubrication (where applicable).

Cleaning should be limited to exterior surfaces only. Removing dust and grease build-up on the motor assures proper motor cooling.

Motors supplied with grease fittings should be greased in accordance with the manufacturer's recommendations.

IMPORTANT!
Do not allow water or solvents to enter the motor or bearings. Motors and bearings should never be sprayed with steam, water or solvents.

IMPORTANT!
Greasing motors is only intended when fittings are provided. Many motors are permanently lubricated, requiring no additional lubrication.

Wheels

Wheels require little attention when moving clean air. Occasionally oil and dust may accumulate on the wheel causing imbalance. When this occurs the wheel and housing should be cleaned to assure proper operation.

Bearings

The bearings for Greenheck fans are carefully selected to match the maximum load and operating conditions of the specific class, arrangement and fan size. The instructions provided in this manual and those provided by the bearing manufacturer will minimize any bearing problems.

IMPORTANT!
Lubricate bearings prior to periods of extended shutdowns or storage and rotate shaft monthly to aid in corrosion prevention. If the fan is stored more than three months, purge the bearings with new grease prior to start-up.

Recommended Bearing Lubrication Schedule for Greenheck Fans					
Relubrication Schedule in Months*					
Fan RPM	Bearing Bore Size (inches)				
	1/2 - 1	1 1/8 - 1 1/2	1 5/8 - 1 7/8	1 15/16 - 2 3/16	2 7/16 - 3
250	6	6	6	6	6
500	6	6	6	5	4
750	6	5	4	3	3
1000	5	3	2	1	1
1250	5	3	2	1	1
1500	5	2	1	1	0.5
2000	5	1	1	0.5	0.25

* Suggested initial greasing interval is based on 12 hour per day operation and 150°F maximum housing temperature. For continuous (24 hour) operation, decrease greasing interval by 50%

- If extended grease lines are present, relubricate while in operation, only without endangering personnel.
- For ball bearings (operating) relubricate until clean grease is seen purging at the seals. Be sure not to unseat the seal by over lubricating.
- For ball bearings (idle) add 1-2 shots of grease up to 2 inch bore size, and 4-5 shots above 2 inch bore sizes with a hand grease gun.
- For roller bearings add 4 shots of grease up to 2 inch bore size, and 8 shots for 2 inch - 5 inch bore size with a hand grease gun.
- Adjust relubrication frequency based on condition of purged grease.
- A high quality lithium based grease conforming to NLGI Grade 2 consistency, such as those listed below.

Mobil 532
Mobilux #2

Texaco Multifak #2
Texaco Premium #2

B Shell Alavania #2
Exxon Unirex N2

Maintenance - Routine

Filters

Filter maintenance is generally limited to cleaning and replacement.

If aluminum mesh filters are installed, they can be washed in warm soapy water.

An adhesive spray can be added to aluminum mesh filters to increase their efficiency.

If disposable filters are installed, they can be checked by holding up to a light source. If light cannot pass through the filter, it should be replaced.

Evaporative Coolers

The media should be periodically brushed lightly with a soft bristle brush in an up and down motion while flushing with water. This aids in reducing the amount of mineral build-up.

For large amounts of mineral build-up, clean or replace the media and increase the water bleed-off or flush rate.

The cooling media has a useful life of 3 to 5 years depending on the water quality and the bleed-off or flush rate.

IMPORTANT!

Replacement media should be from the same manufacturer and be the same size as the original media provided with the unit.

Cooling Coils

Inspect the coil for signs of corrosion and/or leaks. Repair any leaks as required.

Inspect the coil's surface for foreign material. If the coil surface needs cleaning, clean the coil from the leaving air-side so that foreign material will be washed out of the coil rather than pushed farther in.

Inspect and clean the drain pan to prevent the growth of algae and other organisms.

Chilled Water Coils

Test the circulating fluid for sediment, corrosive products and biological contaminants. Make the necessary corrective measures.

Maintain adequate fluid velocities and proper filtering of the fluid.

If automatic air vents are not utilized, periodic venting of the coil is recommended to remove accumulated air.

IMPORTANT!

When reinstalling filters be sure to install them with the airflow in the correct direction. An airflow direction arrow is located on the side of the filters.

IMPORTANT!

Replacement filters should be from the same manufacturer and the same size as the original filters provided with the unit.

IMPORTANT!

When reinstalling the evaporative media, make sure that it is installed correctly. See Media Orientation drawing below.

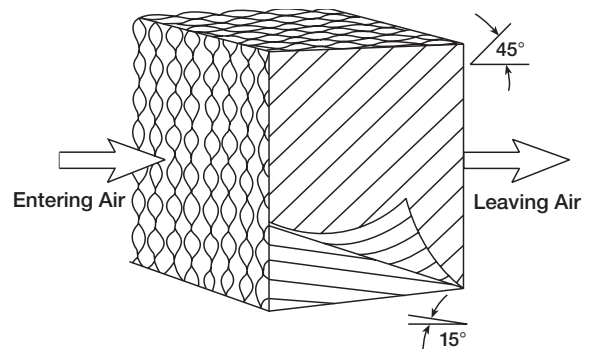

Media Orientation

WARNING!

Repair and replacement of the coil and the connecting piping, valves, etc., should be performed by a qualified individual.

IMPORTANT!

Be sure to read and follow the manufacturer's recommendations before using any cleaning fluid.

CAUTION!

Caution should be used to avoid injury when venting the coil. High pressure and/or high temperature fluids can cause serious injuries.

Maintenance - Fall

Start-Up

Repeat the Blower Start-Up procedure #5 and Direct Gas Start-Up procedure #1 and 3. This will ensure that the gas and air are set properly before the heating season begins, and should lead to trouble free operation all winter.

High Limit

The high limit switch may have tripped over the summer, it should be checked and reset if necessary.

Burner

Inspect the burner for accumulation of scales on both the upstream and downstream sides of the mixing plates. Any scaling or foreign material should be removed with a wire brush.

Visually check that all holes in the mixing plates are clear. If any burner ports are plugged (even partially), clear them with a piece of wire or another appropriate tool.

Replace or tighten any loose or missing fasteners on the mixing plates. Always use zinc plated or stainless steel fasteners.

Inspect and clean the flame and spark rod. Occasional replacement of the flame rod and spark rod may be necessary to ensure optimum unit performance.

WARNING!

Do not enlarge burner ports when clearing a blockage, performance could be affected.

NOTE!

Flame rods can last many years, but because of thermal expansion of the porcelain, flame rods can fail over time.

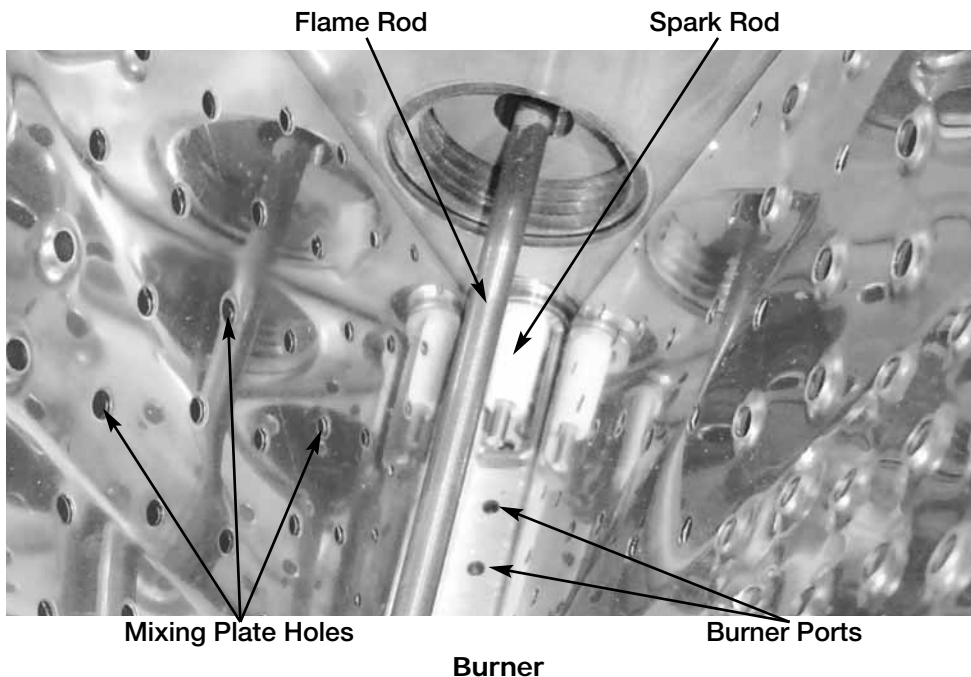

Evaporative Coolers

The water should be shut off and all the lines drained when the outside temperature drops below 45°F.

Remove drain plugs for the winter.

Clean all interior parts of any mineral deposits or foreign materials that may have built-up during the cooling season.

Replace any worn or non-functioning parts.

Maintenance - Fall

Winterizing Chilled Water Coils

During the winter, chilled water coils need to be protected against freezing. Greenheck recommends protecting the coils by either blowing-out the coils or by flushing the coils.

Blowing-Out Coils

1. Close valves on the supply and return line.
2. Open drain valves and/or drain plug. Remove vent plug to allow coil to drain faster.
3. After coil is fully drained, connect a blower to the caps. Do not connect the blower to the air vent or drain plug.
4. Close the vent plug on the header that the blower is connected to. Open the drain valve or cap on the other header.
5. Turn on blower for 30 minutes. Place mirror at discharge. If the mirror fogs up, repeat procedure until no fog appears on the mirror.
6. After drying the coil, wait a few minutes then repeat Step 5.
7. Leave drains open and do not install plugs until beginning of cooling season.

Flushing Coils

Greenheck recommends the use of inhibited glycol (such as propylene or ethylene) to flush water coils to protect against freezing. Additionally, the use of inhibited glycol provides corrosion protection.

The tables below indicate the percentage of glycol required to prevent freezing in a coil at a given outdoor air freeze point. Completely fill coil with solution. Drain coil. Residual glycol fluid per these concentrations can be left in the coil without concern of freezing. Recovered fluid can be used to flush other coils.

% Ethylene Glycol by Volume	Freeze Point (°F)
0	32
10	25
20	16
30	3
40	-13
50	-34
60	-55

% Propylene Glycol by Volume	Freeze Point (°F)
0	32
10	26
20	19
30	8
40	-7
50	-28
60	-60

Reference

Typical Gas Train Layout with Direct Spark Ignition

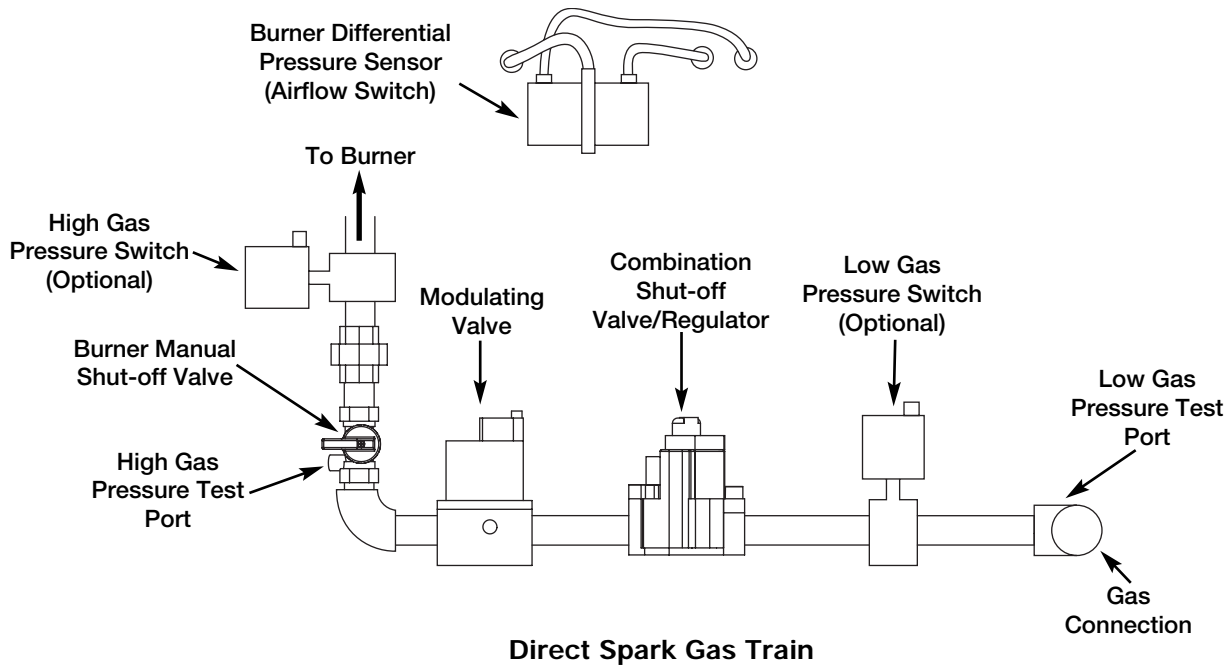

NOTE!

This is a typical gas train. The gas train in your unit may be different.

Reference

Control Center Layout

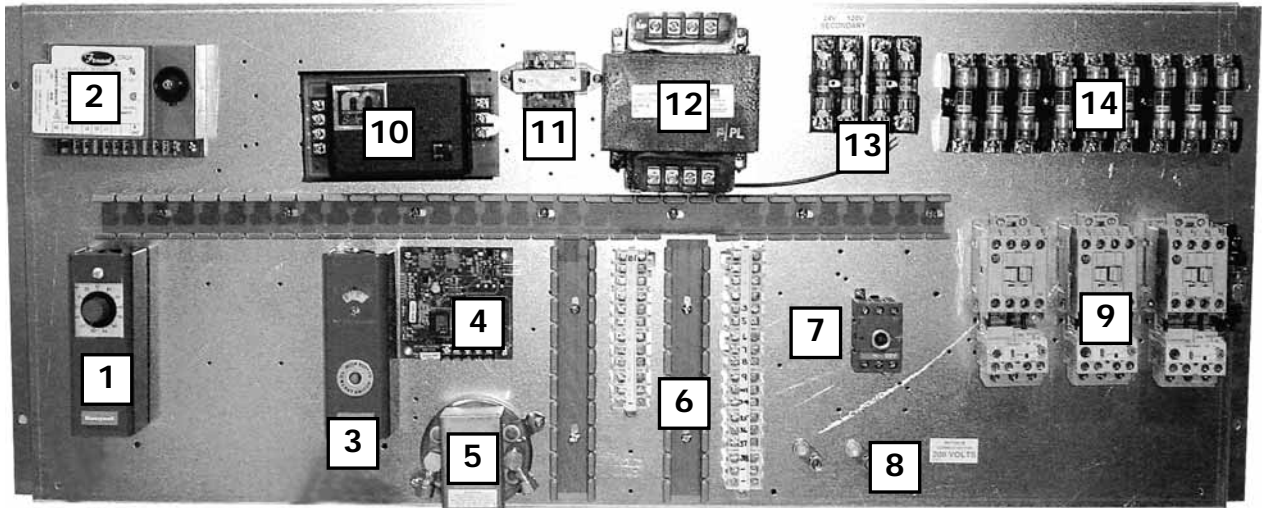

Direct Spark Gas Control Center

1. Heating/Cooling Inlet Air Sensor (Optional) - Ductstat that automatically de-energizes burner when inlet air temperature rises above set point, or shuts down cooling when temperature falls below set point.
2. Flame Safeguard/Spark Generator - Monitors flame, shuts down unit when unsafe conditions are detected.
3. High Limit - Prevents unit from discharging air above a set point.
4. Building Freeze Protection (Optional) - Prevents unit from discharging air below a set point after a time delay. Temperature and time delay are field adjustable.
5. Filter Gauge (Optional) - Monitors filter pressure drop, turns on indicating light when pressure drop is above field adjustable set point.
6. Terminal Strip - 24 Volt power strip for control wiring.
7. Main Disconnect - On/Off switch, provides single point power connection to unit.
8. Grounding Lugs - Completes electrical circuit
9. Motor Starters - 24 Volt magnetic contacts for starting motors, comes standard with electronic overload, may be provided with auxiliary contacts.
10. Amplifier - Controls modulating valve, assures the desired temperature is delivered.
11. Low Voltage Transformer - Reduces voltage to the Maxitrol system.
12. Transformers - multiple transformers provide appropriate voltage to controls, blowers, etc.
13. Secondary fuses - Provides proper fusing for all electrical components other than the motors.
14. Motor Fuses - Provides proper fusing for supply and exhaust fan motor(s).

Dirty Filter Switch

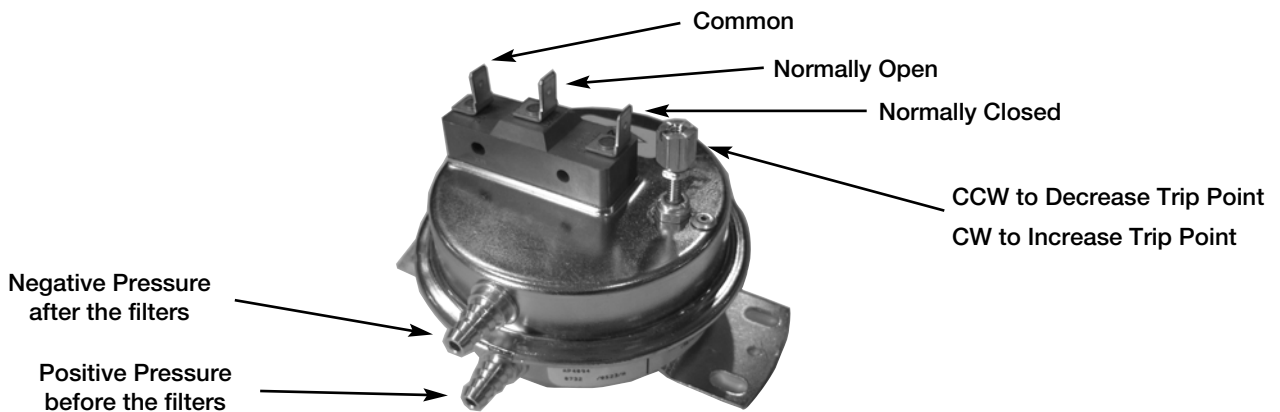

Reference

Start-Up Checklist

Unit Model Number _____ (e.g. DGX-120-H32-DB)
 Unit Serial Number _____ (e.g. 04C99999 or 10111000)
 Start-up date _____ (MM/DD/YYYY)
 Start-up Personnel Name _____
 Start-up Company _____
 Phone Number _____

Pre Start-Up Checklist - check boxes as items are completed

- Check tightness of all factory wiring connections
- Verify control wiring wire gauge
- Hand-rotate blower to verify free rotation
- Verify supply voltage to the main disconnect
- Verify the supply gas pressure
- Verify remote controls wiring

Start-Up Blower Checklist - refer to IOM for further detail

- Check line voltage L1-L2 _____ L2-L3 _____ L1-L3 _____
- Check blower rotation
- Check for vibration.
- Supply fan RPM _____ RPM
- Motor nameplate amps _____ Amps
- Actual motor amps _____ Amps
- Actual CFM delivered _____ CFM

Optional Accessories - refer to IOM for further detail

Optional component	Actual Setting	Typical Setting
<input type="checkbox"/> Heating inlet air sensor	_____	60-70° F
<input type="checkbox"/> Cooling inlet air sensor	_____	75° F
<input type="checkbox"/> Building freeze protection	_____	5 minutes; 45° F
<input type="checkbox"/> Dirty filter gauge	_____	varies
<input type="checkbox"/> Solid fuel time delay	_____	varies

Start-Up Direct Gas - refer to IOM for further detail

- Check supply gas pressure _____ Maximum _____ Minimum _____ Actual
- Set optional High gas pressure switch _____ Actual (Typical 8 in. wc.)
- Set optional Low gas pressure switch _____ Actual (Typical 3 in. wc.)
- Set burner pressure differential _____ Actual (Typical 0.65 in. wc.)
- Set the maximum firing rate _____ temp rise
- Set the minimum firing rate _____ check
- Set the unit's operating temperature _____ degrees F

*This manual is the property of the owner, and is required for future maintenance.
Please leave it with the owner when you complete the job.*

Warranty

Greenheck warrants this equipment to be free from defects in material and workmanship for a period of one year from the purchase date. Any units or parts which prove defective during the warranty period will be replaced at our option when returned to our factory, transportation prepaid.

Motors are warranted by the motor manufacturer for a period of one year. Should motors furnished by Greenheck prove defective during this period, they should be returned to the nearest authorized motor service station. Greenheck will not be responsible for any removal or installation costs.

As a result of our commitment to continuous improvement,
Greenheck reserves the right to change specifications without notice.

