

**Honeywell Actuators Direct Drive
 MS4120, MS4620, MS8110, MS8120,
 MS7510, and MS7520**

These instructions apply to the external field installation of Honeywell actuators on Greenheck control dampers. These models are direct drive actuators that rotate to their energized position when power is applied and spring return to their fail position when power is disconnected.

Model	Volts	Running	Holding
MS4120F1006	120 VAC	35W	10W
MS4120F1204			
MS4620F1005	230 VAC	35W	10W
MS4620F1203			
MS7510A2008	24 VAC/VDC	14W	5W
MS7510A2206		14W	
MS7520A2007		16W	
MS7520A2015		22W	
MS7520A2205		16W	
MS7520A2213		22W	
MS8110A1206	24 VAC/VDC	30W	8W
MS8120F1002	24 VAC	45W	10W
MS8120F1200			

Galvanized Steel Kit

Item	Part #	Description	Qty
1	723089	Anti-rotation bracket	1
2	815027	Extension pin support bracket	1
3	415455	¼ - 20 splinlock ZP nut	9
4	416048	¼ x ¾ shoulder bolt	1
5	415934	#10-24 HH Nylock ZP nut	1
6	417272	Mounting stud (not shown)	1
7	415264	¼ - 20 x ½ ZP bolt	8
8	-	Actuator	1

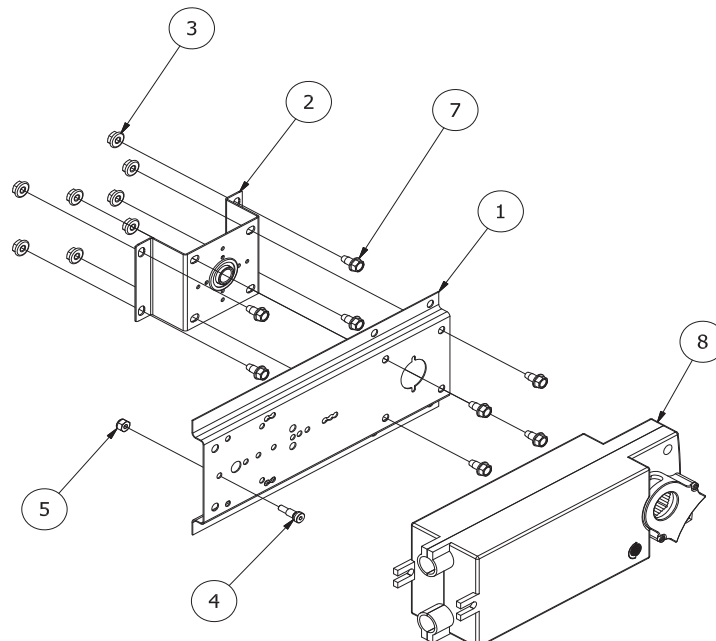

Instructions for Galvanized Steel Kit

1. Determine actuator fail position and change actuator clamp location if necessary.
2. Lock the actuator clamp in place using the retaining clamp.

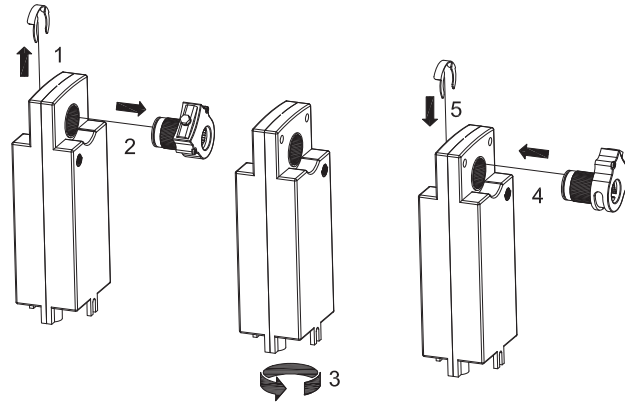

3. Remove the bearing from the stand-off bracket (jackshaft only).
4. Install stand-off bracket. Mark and drill 9/32 in. holes (extension pin only).

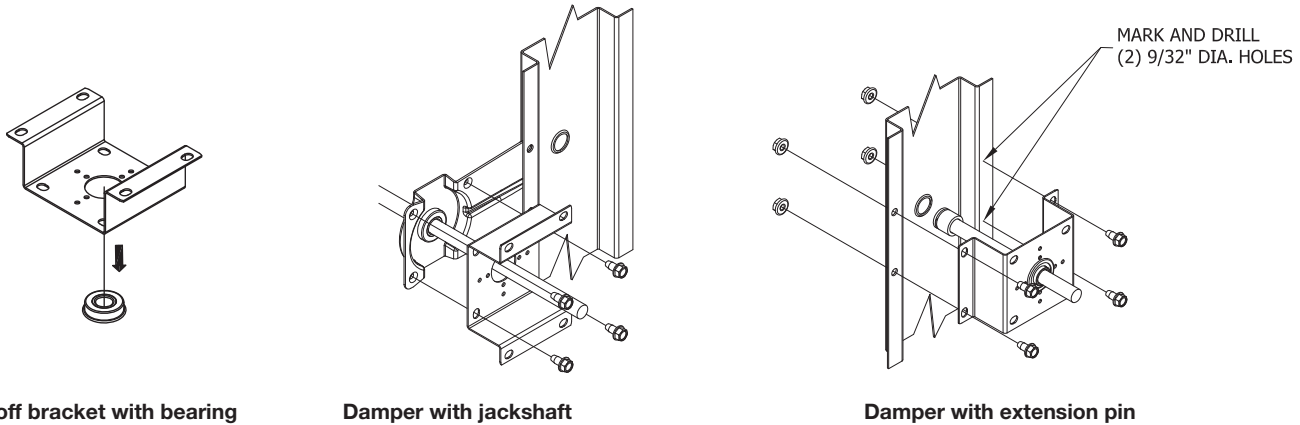

Standoff bracket with bearing

Damper with jackshaft

Damper with extension pin

5. Install anti-rotation bracket and actuator. Anti-rotation bracket may be attached (a) perpendicular up, (b) perpendicular down, or (c) parallel from duct (shown).

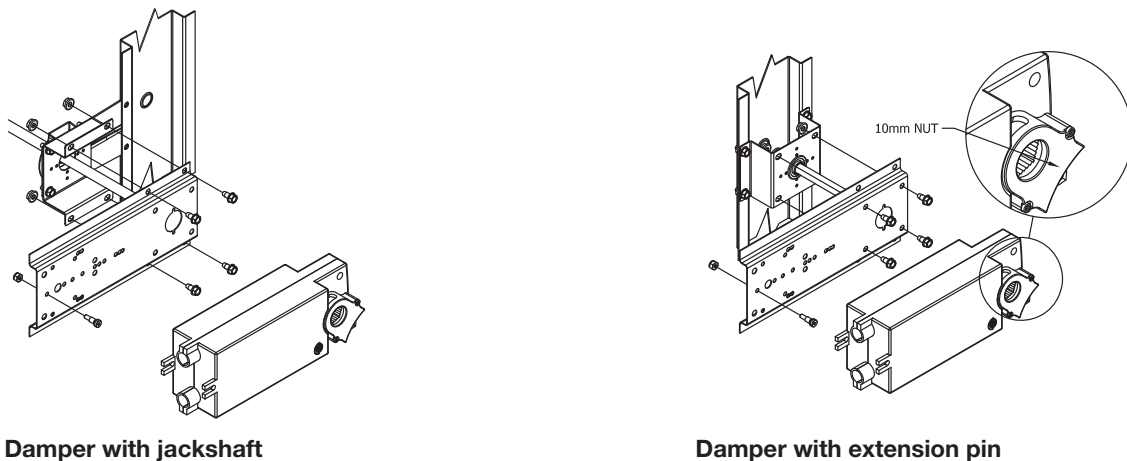

Damper with jackshaft

Damper with extension pin

6. Rotate damper blades to desired fail position (open) or (closed, ensure blade seals are compressed). Tighten 10 mm hex screw to allow 95 degrees of actuator rotation.
7. Wiring should be per an approved project or job wiring diagram and must comply with all applicable wiring codes.
8. Apply power to the actuator. Damper blades should fully open or close and return to the fail position when power is disconnected.

316 Stainless Steel Kit

Item	Part #	Description	Qty
1	689986	Anti-rotation bracket, 316SS	1
2	687405	Ext pin support bracket, 316SS	1
3	687784	Standoff bracket, 316SS	1
4	416767	#10-24 x 3/8 bolt, 316SS	1
5	416204	1/4 lock washer 316SS	1
6	415864	#10-24 Hex nut, 316SS	1
7	415868	1/4-20 x 1/2 stud, 316SS	8
8	417305	1/4 - 20 x 1/2 spinlock bolt, 316SS	8
9	-	Actuator	1

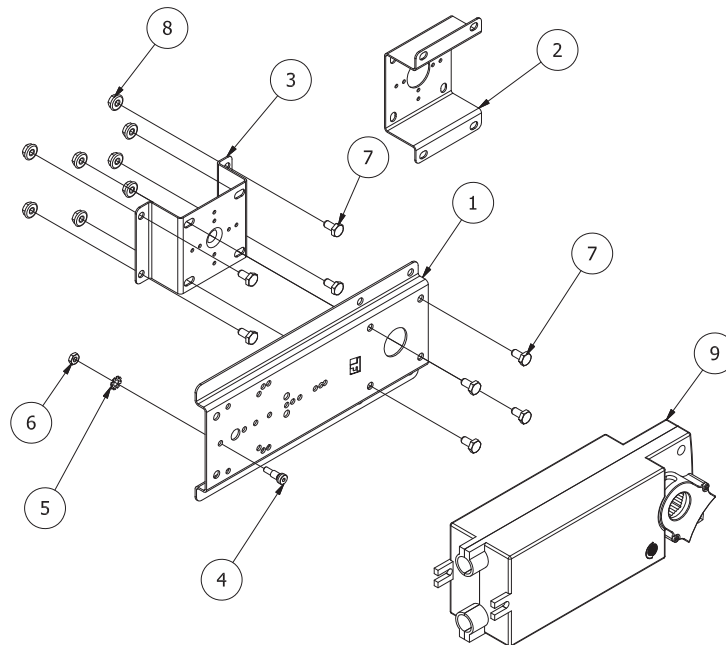

Instructions for 316SS Kit

1. Determine actuator fail position and change actuator clamp location if necessary.
2. Lock the actuator clamp in place using the retaining clamp.

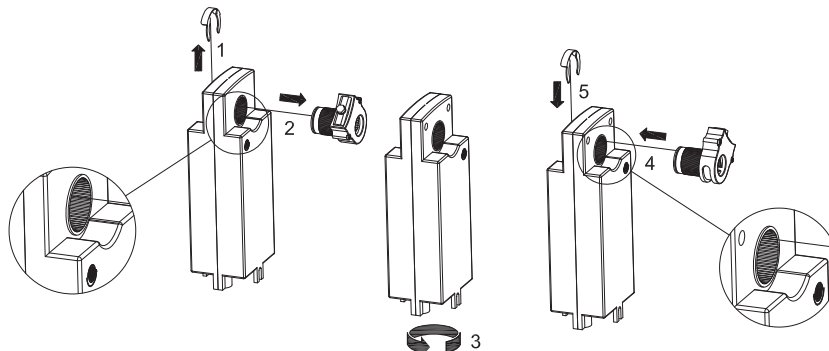

3. Install stand-off bracket. Mark and drill $\frac{9}{32}$ in. holes (extension pin only).

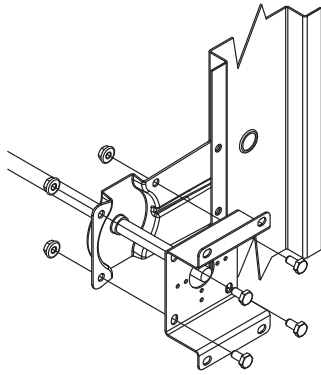

Damper with jackshaft

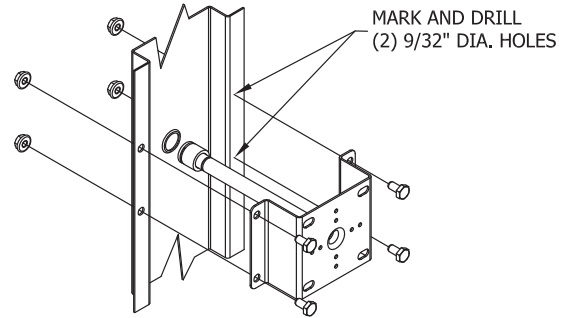

Damper with extension pin

4. Install anti-rotation bracket and actuator. Anti-rotation bracket may be attached (a) perpendicular up, (b) perpendicular down, or (c) parallel from duct (shown).

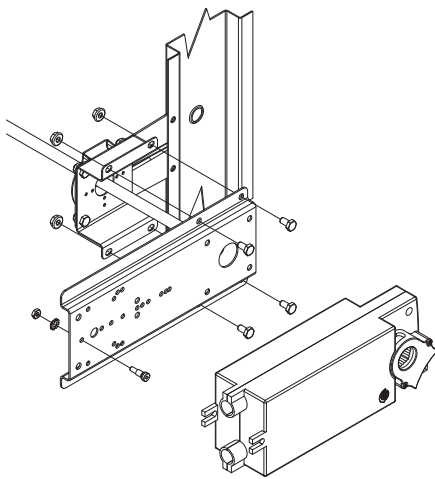

Damper with jackshaft

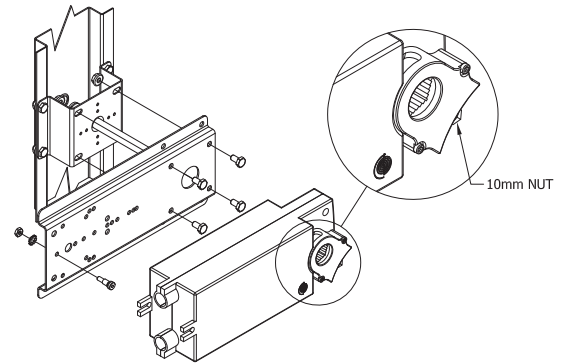

Damper with extension pin

5. Rotate damper blades to desired fail position (open) or (closed, ensure blade seals are compressed). Tighten 10 mm hex screw to allow 95 degrees of actuator rotation.
6. Wiring should be per an approved project or job wiring diagram and must comply with all applicable wiring codes.
7. Apply power to the actuator. Damper blades should fully open or close and return to the fail position when power is disconnected.

Our Commitment

As a result of our commitment to continuous improvement, Greenheck reserves the right to change specifications without notice.

Product warranties can be found online at Greenheck.com, either on the specific product page or in the literature section of the website at Greenheck.com/Resources/Library/Literature.

