

## Installation, Operation and Maintenance Manual

Please read and save these instructions for future reference. Read carefully before attempting to assemble, install, operate or maintain the product described. Protect yourself and others by observing all safety information. Failure to comply with these instructions will result in voiding of the product warranty and may result in personal injury and/or property damage.

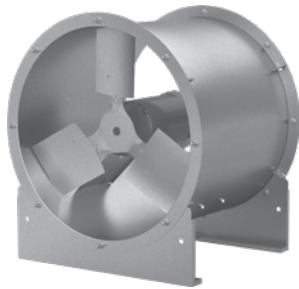

AX 100 Series



AX  
Standard Long Casing



AX-V  
Optional Vane Section



AX-S  
Optional Supply



AX-U  
Optional Roof Upblast

### General Safety Information

Only qualified personnel should install this unit. Personnel should have a clear understanding of these instructions and should be aware of general safety precautions. Improper installation can result in electric shock, possible injury due to coming in contact with moving parts, as well as other potential hazards. Other considerations may be required if high winds or seismic activity are present. If more information is needed, contact a licensed professional engineer before moving forward.

1. Follow all local electrical and safety codes, as well as the National Electrical Code (NEC), the National Fire Protection Agency (NFPA), where applicable. Follow the Canadian Electric Code (CEC) in Canada.
2. The rotation of the propeller is critical. It must be free to rotate without striking or rubbing any stationary objects.
3. Motor must be securely and adequately grounded.
4. Do not spin fan propeller faster than the maximum cataloged fan rpm. Adjustments to fan speed with Variable Frequency Drives (VFD) may affect motor load. If the fan RPM is changed, the motor current should be checked to make sure it is not exceeding the motor nameplate amps.
5. Do not allow the power cable to kink or come in contact with oil, grease, hot surfaces or chemicals. Replace cord immediately if damaged.
6. Verify that the power source is compatible with the equipment.

#### DANGER

Always disconnect, lock and tag power source before installing or servicing. Failure to disconnect power source can result in fire, shock or serious injury.

#### CAUTION

When servicing the fan, motor may be hot enough to cause pain or injury. Allow motor to cool before servicing.

#### CAUTION

Precaution should be taken in explosive atmospheres.

## Receiving

Upon receiving the product, check to ensure all items are accounted for by referencing the delivery receipt or packing list. Inspect each crate or carton for shipping damage before accepting delivery. Alert the carrier of any damage detected. The customer will make a notation of damage (or shortage of items) on the delivery receipt and all copies of the bill of lading which is countersigned by the delivering carrier. If damaged, immediately contact your sales representative. Any physical damage to the unit after acceptance is not the responsibility of the manufacturer.

## Unpacking

Verify that all required parts and the correct quantity of each item have been received. If any items are missing, report shortages to your local representative to arrange for obtaining missing parts. Sometimes it is not possible that all items for the unit be shipped together due to availability of transportation and truck space. Confirmation of shipment(s) must be limited to only items on the bill of lading.

## Handling

Handle in such a manner as to keep from scratching or chipping the coating. Fans should not be lifted by the motor shaft, motor housing or fan accessories. Damaged finish may reduce ability of unit to resist corrosion.

## Storage

Units are protected against damage during shipment. If the unit cannot be installed and operated immediately, precautions need to be taken to prevent deterioration of the unit during storage. The user assumes responsibility of the unit and accessories while in storage. The manufacturer will not be responsible for damage during storage. These suggestions are provided solely as a convenience to the user.

**INDOOR** — The ideal environment for the storage of units and accessories is indoors, above grade, in a low humidity atmosphere which is sealed to prevent the entry of blowing dust, rain, or snow. Temperatures should be evenly maintained between 30°F (-1°C) and 110°F (43°C) (wide temperature swings may cause condensation and “sweating” of metal parts). All accessories must be stored indoors in a clean, dry atmosphere.

Remove any accumulations of dirt, water, ice, or snow and wipe dry before moving to indoor storage. To avoid “sweating” of metal parts allow cold parts to reach room temperature. To dry parts and packages, use a portable electric heater. Leave coverings loose to permit air circulation and to allow for periodic inspection.

The unit should be stored at least 3-1/2 inches (89 mm) off the floor on wooden blocks covered with moisture proof paper or polyethylene sheathing. Aisles between parts and along all walls should be provided to permit air circulation and space for inspection.

**OUTDOOR** — Units designed for outdoor applications may be stored outdoors, if absolutely necessary. Roads or aisles for portable cranes and hauling equipment are needed.

The fan should be placed on a level surface to prevent water from leaking into the unit. The unit should be elevated on an adequate number of wooden blocks so that it is above water and snow levels and has enough blocking to prevent it from settling into soft ground. Locate parts far enough apart to permit air circulation, sunlight, and space for periodic inspection. To minimize water accumulation, place all unit parts on blocking supports so that rain water will run off.

Do not cover parts with plastic film or tarps as these cause condensation of moisture from the air passing through heating and cooling cycles.

## Inspection and Maintenance during Storage

While in storage, inspect fans once per month. Keep a record of inspection and maintenance performed.

If moisture or dirt accumulations are found on parts, the source should be located and eliminated. At each inspection, rotate the fan propeller by hand ten to fifteen revolutions to distribute lubricant on motor. If paint deterioration begins, consideration should be given to touch-up or repainting. Fans with special coatings may require special techniques for touch-up or repair.

Machined parts coated with rust preventive should be restored to good condition promptly if signs of rust occur. Immediately remove the original rust preventive coating with petroleum solvent and clean with lint-free cloths. Polish any remaining rust from surface with crocus cloth or fine emery paper and oil. Do not destroy the continuity of the surfaces. Wipe thoroughly clean with Tectyl® 506 (Ashland Inc.) or the equivalent. For hard to reach internal surfaces or for occasional use, consider using Tectyl® 511M Rust Preventive or WD-40® or the equivalent.

**REMOVING FROM STORAGE** — As units are removed from storage to be installed in their final location, they should be protected and maintained in a similar fashion, until the equipment goes into operation.

Prior to installing the unit and system components, inspect the unit assembly to make sure it is in working order.

1. Check all fasteners on the fan, propeller, motor base, and accessories for tightness.
2. Rotate the fan propeller by hand and assure no parts are rubbing.
3. Fans should not be lifted by the motor shaft, motor housing or fan accessories.

## Lifting



**Standard  
Long Casing**



**Optional  
Vane Section**

Fan models AX or AX-V are to be lifted using a minimum of four (4) points on the fan housing or attach two suitable chains/straps around the entire fan housing, one near each duct flange.

For flange mounted fans, attach suitably sized chains or lifting straps to two locations on the inlet and outlet flanges as shown.

For fans with Universal Mounting brackets, use brackets for lifting connection points.

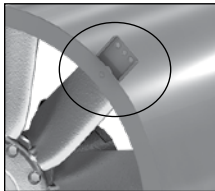

**Roof Upblast**

Fan model AX-U are to be lifted using the four (4) windband gussets located between the butterfly damper section of the fan and the exterior windband **unless** welded lifting lugs are provided on fan housing. Welded lifting lugs are present on AX-113 thru AX-160.

A spreader bar is recommended to prevent damage to the damper section when lifting.

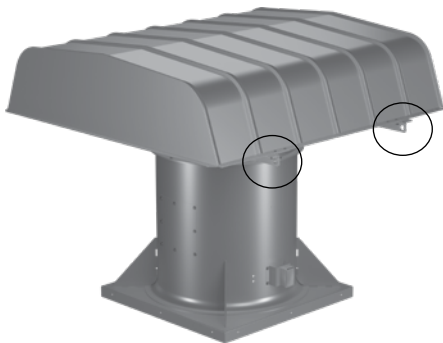

**Roof Supply**

Fan model AX-S are to be lifted using the four (4) brackets under the weatherhood section of the fan. A spreader bar is recommended to prevent damage to the weatherhood section when lifting.

## Effects of Installation on Performance

Any installation with inlet or discharge configurations that deviate from these recommendations may result in reduced fan performance. Restricted or unstable flow at the fan inlet can cause pre-rotation of incoming air or uneven loading of the fan propeller yielding large system losses and increased sound levels. Free discharge or turbulent flow in the discharge ductwork will also result in system effect losses.

The most common inlet and discharge conditions which affect fan performance are inlet and discharge duct turns.

### Inlet Duct Turns

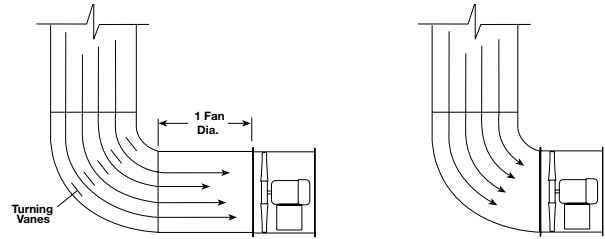

**Good**

**Poor**

Installation of a duct turn or elbow too close to the fan inlet reduces fan performance because air is loaded unevenly into the fan prop. To achieve full fan performance there should be at least one to two fan diameters between the turn or elbow and the fan inlet.

### Discharge Duct Turns

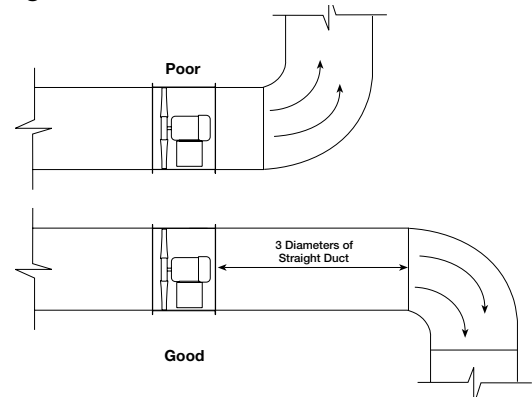

**Good**

Fan performance is reduced when duct turns are made immediately off the fan discharge. To achieve cataloged fan performance, there should be at least three equivalent fan diameters of straight ductwork between the fan discharge and any duct turns.

### NOTE

For curb mounted exhaust or supply systems using "Bottom Inlet" duct connections, installation of drain locations within the ductwork is recommended to allow for safe removal of any water that enters the duct system. This requires the installing contractor to determine whether insulation, watertight construction, or sloped and drained ductwork are required. For curb mounted exhaust or supply systems with "Free Inlet Bottom Intake" connections (free air inlet conditions), it is recommended to install a moisture collecting drip pan at least one housing diameter below the inlet of the fan.

# Typical Installations

## NOTE

For units supplied or used with a Variable Frequency Drive (VFD), reference the VFD documentation for installation requirements, start-up settings, parameter adjustments and trouble shooting. VFDs provided by Greenheck are factory programmed for basic motor parameters, incoming voltage parameters and maximum operating speed (Hz).

Follow NEC and local codes for VFD wiring and installation. If the wire length between the VFD and the controlled motor exceeds 100 ft (30.5 m), DV/DT filters or VFD cabling may be required. Calculations and proper application of DV/DT filters and VFD cabling is by others; failing to do so may result in premature motor failure.

VFDs supplied with the AX-100 do have parameters pre-loaded.

The examples shown below are common installations of the different housing options with and without optional universal mounting brackets. Before beginning installations, reference the airflow direction as indicated by the direction decal attached to the fan. Note that airflow for AX units with straightening vanes is opposite of the standard AX long casing design.



### Units with Flange Mounting

- Upblast, Downblast or Horizontal

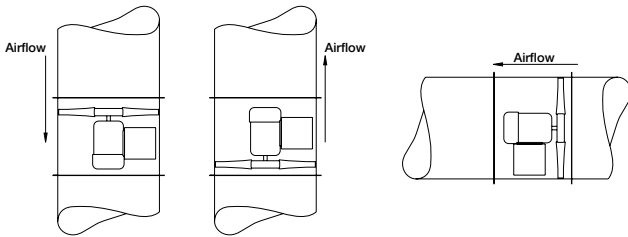

### Units with Universal Mounting Brackets (Optional)

- Vertical, Ceiling Mount with Isolators, Downblast or Upblast

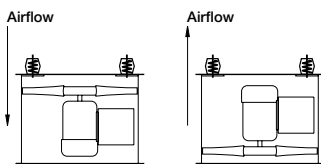

- Vertical, Base Mount, Downblast or Upblast

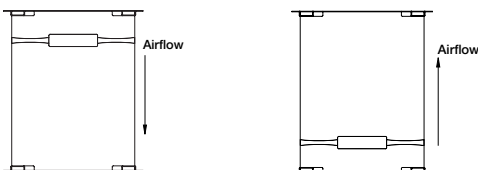

- Horizontal, Floor or Ceiling Mount with Isolators

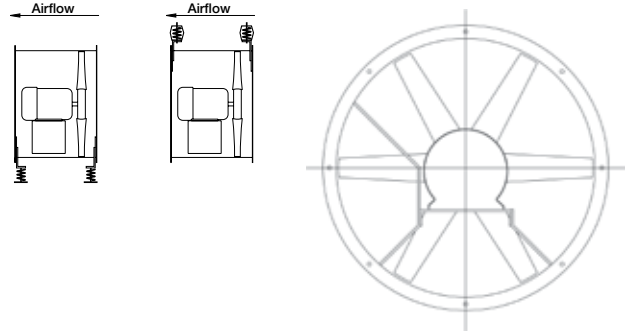

## NOTE

Always orientate the unit as shown, with the motor above the motor plate. Motor weight should be resting on the motor plate when the fan is mounted horizontally.

- Roof Upblast and Supply on a Roof Curb

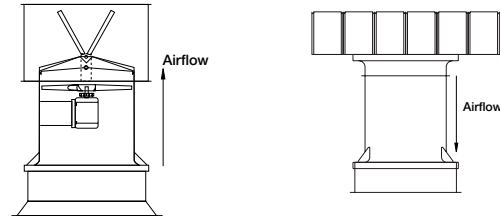

## Operation and Unit Start-Up

### Electrical Connections

Before electrical connections are made, the supply voltage, phase and ampere capacity must be checked for compatibility with the fan motor. In addition, the supply wiring must be properly fused and conform to local and national electrical codes.

The supply wires are then connected to an **optional** safety disconnect switch, to the **optional** wiring pigtail, or directly to the motor junction box.

### Pre-Start-Up Checks

1. Check all fasteners for tightness. Fasteners may come loose during transit or handling at the jobsite. This includes motor bolts, mounting brackets, and bushing bolts attaching the propeller to the motor shaft.
2. Propeller rotation should be in the same direction as the rotation decal affixed to the unit. For 3-phase installations, fan rotation can be reversed by simply interchanging any two of the three electrical leads. For single phase installations, follow the wiring diagram located on the motor.



**Propeller Rotation  
Decal**

# Performance Adjustments

## Field Performance Adjustments

The performance of an AX 300 fan can be adjusted through the use of a variable speed drive (VFD) or adjusting the fan pitch. Both can be effectively used for final air balancing. Note that any change, increase or decrease in fan speed (RPM) or blade pitch, can represent a substantial increase in power required from the motor. Check motor load amperage and compare to nameplate rating when changing the fan speed or blade pitch. AX 100/200 series fans will not have adjustable pitch blades.

### Adjusting Performance with a Variable Frequency Drive (VFD)

Before wiring a VFD, determine that the motor is compatible with this type of equipment. Connecting a VFD to a non-compatible motor may reduce the life of the motor. Additionally, it is important to properly ground fans being wired with a VFD. For more information on these subjects, refer to Greenheck document "Are Bearing Currents Causing Your Motor Failures?" located at [www.greenheck.com](http://www.greenheck.com). Click on Resources, Library, Application Articles, and use the keyword "Bearing". The manufacturer is not responsible for improper wiring of a VFD or for potential motor damage as a result of operating a fan over its maximum operating frequency.

### Adjusting Performance through Blade Pitch Adjustments (AX 300 Series)

The blade pitch can be adjusted without removing the propeller from the fan casing. Steps to adjust the blade pitch are as follows:

1. Determine the new blade pitch required with your local sales representative. Verify that the motor has sufficient capacity to handle the new power requirements.
2. Disconnect and lock out all power to the fan to prevent accidental start-up.
3. Gain access to the propeller side of the fan. This may require removing the fan from the existing duct system or dismantling ductwork to gain access.
4. Loosen the blades to the point where they can be rotated in the hub. Hub and blade fastening vary by fan size. Hub styles and bolt torque requirements are provided. Do NOT pound on the blades to adjust the pitch. They should be snug, but movable by hand.
5. Use the blade pitch protractor found on the website ([www.greenheck.com](http://www.greenheck.com)) to adjust the pitch. Follow the directions stated on the guide for determining blade pitch.
6. Adjust one blade to the desired pitch angle and remove the protractor sheet.
7. Use a marker to trace the profile of the blade on the fan housing.
8. Adjust the remaining blades to the traced profile.

9. Retighten the hub to the torque specs detailed below per hub size.
10. Reinstall the fan or any duct pieces that were removed.
11. Review the Operation and Start-Up procedures listed earlier in this manual.
12. After start-up, make a final check of the fan amps to ensure the motor is not overloaded.

## Torque Specifications for Bushings and Propeller Bolts

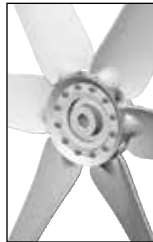

### HUB SIZE: 160 mm

Bushing bolts 9 ft-lb / 12.2 N-m  
Propeller bolts 7 ft-lb / 9.5 N-m

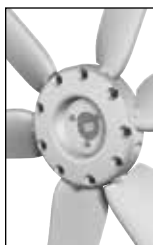

### HUB SIZE: 275 mm

Bushing bolts 16 ft-lb / 21.7 N-m  
Propeller bolts 21 ft-lb / 28.5 N-m



### HUB SIZE: 400 mm

Bushing bolts 27 ft-lb / 36.6 N-m  
Propeller bolts 40 ft-lb / 54.2 N-m

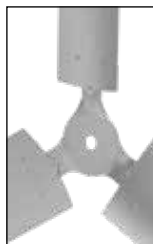

### HUB SIZE: 533 mm

Bushing bolts 40 ft-lb / 54.2 N-m  
Blade Nuts 125 ft-lb / 169.5 N-m

### AX 100 HUB Data

Set screw torque 12.5 ft-lb / 16.9 N-m

## NOTE

Fans configured for reversible operation have blades installed both in a forwards and backwards facing direction. The blade pitches are the same, but in opposite directions. When making blade pitch adjustments, first do one set of blades all in the same orientation and then repeat the adjustment on the other backward facing blades.

## Maintenance

Once the unit has been put into operation, a routine maintenance schedule should be set up to accomplish the following:

1. Lubrication of motor.
2. Propeller, housing, and bolts on the entire fan should be checked for tightness.
3. Any dirt accumulation on the propeller or in the housing should be removed to prevent unbalance and possible damage.
4. Inspection of fan propeller and housing looking for fatigue, corrosion, or wear.

When performing any service to the fan, disconnect the electrical supply and secure fan propeller.

### Motors

Motor maintenance is generally limited to cleaning and lubrication. Cleaning should be limited to exterior surfaces only. Removing dust and grease buildup on the motor housing assists proper motor cooling. Never wash-down motor with high pressure spray.

Greasing of motors is only intended when fittings are provided. Many motors are permanently lubricated for life and require no further lubrication. Motors supplied with grease fittings should be greased in accordance with the motor manufacturer's recommendations.

### Fasteners and Set Screws

A periodic inspection should include checking all fasteners and bolts for tightness. Particular attention should be paid to the bushing attaching the propeller to the motor shaft and the motor to its mounting fixture.

### Removal of Dust and Dirt

Dirt clogs cooling openings on the motor housing, contaminates bearing lubricant, and collects on the propeller causing severe imbalance if left unchecked. The exterior surface of the motor and propeller should be thoroughly cleaned periodically. Use caution and do not allow water or solvents to enter the motor. Under no circumstances should motors be sprayed with steam or water.

## Parts List

Each fan bears a manufacturer's nameplate with model number and serial number embossed. This information, in addition to the shown parts diagram, will assist the local sales representative and the factory in providing service and replacement parts.

Nameplates are mounted in an area which is clearly visible, usually near the fan outlet. The exact tag location may differ with fan model and size.

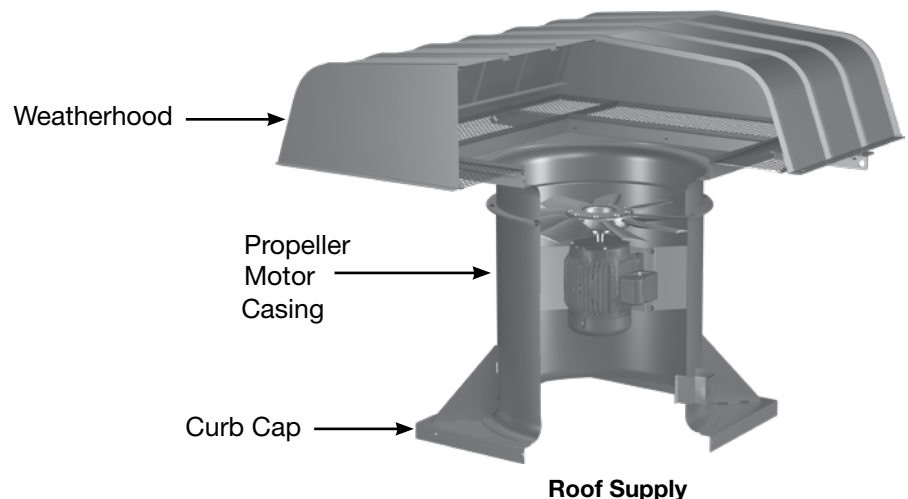
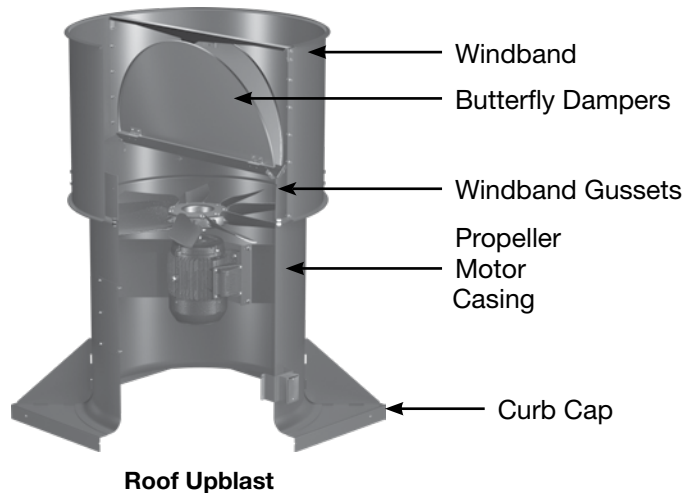
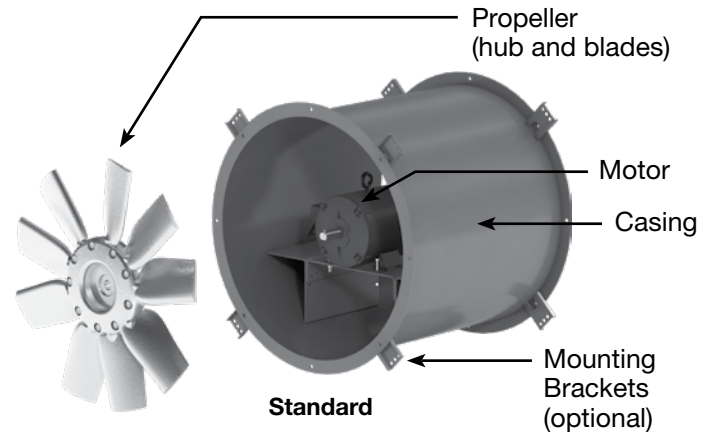

## Field Coating Touch-Up Procedure for Scratched Areas

Standard coating and color is RAL 7023 Concrete Grey. The procedure outlines the correct method for repairing minor scratches in the coating.

### TOUCH-UP PAINT REPAIR KIT CONTENTS

- One pint of Kem Kromik® primer
  - including a technical data sheet
- One pint of industrial enamel
  - including a technical data sheet
- Four disposable foam brushes
- One sheet sand paper
- Repair procedure details

1. Scuff affected are to be repaired using medium sandpaper (provided) or medium Scotch Brite™ pad. Feather the edges.
2. Clean affected area to be touched up using an alkaline-based cleaner and rinse.
3. Apply Kem Kromik® primer using 1-inch foam brush (provided). Follow technical data sheet instructions.
4. Allow primer to dry a minimum of 2-1/2 hours before top coating.
5. Apply topcoat with industrial enamel using a 1-inch foam brush (provided). Follow technical data sheets instructions. Allow painted units to air-dry and cure before putting into service. See Technical Data sheets (included with kit) for detailed drying and cure schedules at different temperatures.

### NOTE

While the manufacturer provides heavy-duty, quality products for marine environments, routine paint touch-ups may be required in coastal regions where salt or marine air could damage the coating. The severe environment will accelerate the damage from any scratches or chips and it is recommended that those be repaired immediately.

To order a coating repair kit, please reference part number **HAZ2597 RAL 7023 CONCRETE GREY FIELD REPAIR** kit. Please contact factory with your fan's serial number for colors other than our standard.

### Tips to Prolong Coatings Integrity

The coating on our products provide the end user years of protection and beauty. Some additional preventative maintenance will extend the integrity of the coating.

- Wipe down flat surfaces that may collect chips or shavings resulting from installation.
- Check for areas of corrosion annually and repair with Greenheck touch-up kit. Nicks and scratches from the installation, maintenance or wind abrasion may allow corrosion to start. Touching up these spots will stop further damage.
- Wipe down the fan's exterior with a mild detergent and rinse annually.

# Maintenance Log

Date \_\_\_\_\_ Time \_\_\_\_\_ AM/PM

Notes: \_\_\_\_\_

\_\_\_\_\_

\_\_\_\_\_

\_\_\_\_\_

\_\_\_\_\_

Date \_\_\_\_\_ Time \_\_\_\_\_ AM/PM

Notes: \_\_\_\_\_

\_\_\_\_\_

\_\_\_\_\_

\_\_\_\_\_

\_\_\_\_\_

Date \_\_\_\_\_ Time \_\_\_\_\_ AM/PM

Notes: \_\_\_\_\_

\_\_\_\_\_

\_\_\_\_\_

\_\_\_\_\_

\_\_\_\_\_

Date \_\_\_\_\_ Time \_\_\_\_\_ AM/PM

Notes: \_\_\_\_\_

\_\_\_\_\_

\_\_\_\_\_

\_\_\_\_\_

\_\_\_\_\_

Date \_\_\_\_\_ Time \_\_\_\_\_ AM/PM

Notes: \_\_\_\_\_

\_\_\_\_\_

\_\_\_\_\_

\_\_\_\_\_

\_\_\_\_\_

Date \_\_\_\_\_ Time \_\_\_\_\_ AM/PM

Notes: \_\_\_\_\_

\_\_\_\_\_

\_\_\_\_\_

\_\_\_\_\_

\_\_\_\_\_

Date \_\_\_\_\_ Time \_\_\_\_\_ AM/PM

Notes: \_\_\_\_\_

\_\_\_\_\_

\_\_\_\_\_

\_\_\_\_\_

\_\_\_\_\_

Date \_\_\_\_\_ Time \_\_\_\_\_ AM/PM

Notes: \_\_\_\_\_

\_\_\_\_\_

\_\_\_\_\_

\_\_\_\_\_

\_\_\_\_\_

## Our Commitment

*As a result of our commitment to continuous improvement, Greenheck reserves the right to change specifications without notice.*

Product warranties can be found online at [Greenheck.com](http://Greenheck.com), either on the specific product page or in the literature section of the website at [Greenheck.com/Resources/Library/Literature](http://Greenheck.com/Resources/Library/Literature).

Greenheck's High Performance Axial Fans catalog provides additional information describing the equipment, fan performance, available accessories, and specification data.

AMCA Publication 410-96, Safety Practices for Users and Installers of Industrial and Commercial Fans, provides additional safety information. This publication can be obtained from AMCA International, Inc. at [www.amca.org](http://www.amca.org).

