

Field Installation Instructions for EM series Backdraft Damper with Counterbalance

Refer to:
 'Installation Instructions for EM and GM Series Dampers' (Part #468391)

Models:
 EM-10 series, Horizontal Mount - Vertical Airflow Up
 EM-30 series, Vertical Mount - Horizontal Airflow
 EM-40 series, Horizontal Mount - Vertical Airflow Down

Application

The Adjustable Pressure Controller (APC) provides mechanical adjustment of start open pressure for the Greenheck model EM series damper. The APC is mounted to the bottom frame member (sill) and connects to the bottom blade linkage pin. Dampers **MUST** be equipped with blade counterbalance.

The ability to resist damper opening is limited per the table below. Note: Adjustable Pressure Controller (APC) is not intended to assist in opening blades or to substitute for counterbalance weights. Use one APC assembly per damper panel.

Area		Maximum Set Pressure	
(ft ²)	(m ²)	(in. wg)	(Pa)
4	0.37	0.75	187
6	0.58	0.50	125
8	0.74	0.40	100
10	0.93	0.30	75
15	1.40	0.20	50
20	1.86	0.15	37
24	2.23	0.125	31

Tools Required:

Drill
 1/64 in. drill bit
 3/8 in. and 7/16 in. combination wrench
 Tape measure
 Needle nose pliers

Item #	Part #	Description	Qty
1	705238	Mounting Bracket	1
2	823936	Control Knob Sub-Assembly	1
3	705241	Release Rod	1
4	653631	1/2 in. Non-Knurled Crankarm	1
5A	705239	Connecting Bar (4 1/8 in. long)	1
5B	705240	Connecting Bar (3 in. long)	1
6	457803	Spring	2
7	454092	5/32 in. x 1.5 Roll Pin - SS	1
8	463906	Link Separator Spring -SS	1
9	415482	3/16 x 1/2 in. nylon washer	2
10	416179	1/2 in. Push-On Retainer-ZP	1
11	451820	1/4 x 0.360 in. Knurl Pin - ZP	1
12	415609	1/4 - 20 x 1/2 in. Threadstud	2
13	415455	1/4 - 20 Spinlock Nut-ZP	2
14	451588	1/4 in. E-clip- ZP	1
15	457806	3/16 in. E-Clip	1
16	415991	#10-32 Keps Nut -SS	2
17	415555	#10 x 1/2 in. Tek Screw - ZP	2
18	416052	#10-32 x 5/8 in. SS Threadstud	2

* See page 2 Table for correct connecting bar

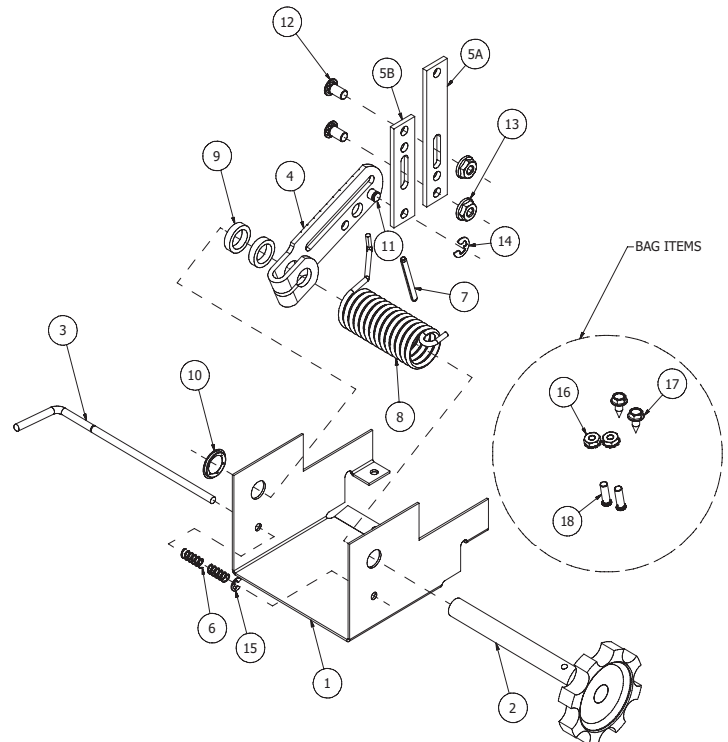

Installation

1. The APC assembly mounts on the inlet (linkage/counterbalance weight) side of the damper. Locate assembly on damper sill so the crankarm is directly under the damper blade lever arm.
2. The mounting bracket (item #1) is designed so the sloped portion of bracket rests on the outer frame flange, with the two ears, one on each side, resting on the highest part of the frame.
3. Fasten through ears using two #10 x 1/2 in. Tek screws, item #17.
4. Use 13/64 in. drill (5mm) to drill through frame on sloped portion of bracket. If accessible, insert two #10-32 x 5/8 in. threadstuds (item# 18) from the exterior and fasten with two #10-32 Keps nut (item #16). If inaccessible, use minimum #12 self-threading screws.
5. See table below to determine quantity and combination of connecting links to be used. The longer link is always to be installed towards the blade (top). Connect link(s) using two 1/4"-20 threadstuds (item #12), and nuts (item #13), with center distance between hole centerlines as indicated. On some short damper heights, only one 5A (4 1/8 in.) or 5B (3 in.) is used. The heads of the threadstuds should be towards the linkage tie bar so the fasteners do not inhibit opening.

Height (in.)	Center Distance	Links to use
10	5.56	5A & B
11	2	5B
12	3.13	5A
13	4	5A & B
14	5.06	5A & B
15	5.25	5A & B
16	2.5	5B
17	3.63	5A
18	4.56	5A & B
20	5.25	5A & B
21	5.56	5A & B
22	4	5A & B
23	5.06	5A & B
24	5.25	5A & B
25	5.25	5A & B
26	5.25	5A & B
27	4.56	5A & B
28	5.25	5A & B
29	5.25	5A & B
30	5.25	5A & B
31	5.25	5A & B
32	5.56	5A & B
33	5.25	5A & B
34	5.25	5A & B
35	5.25	5A & B
36	5.25	5A & B
37	5.25	5A & B
38	5.25	5A & B
39	5.25	5A & B
40	5.25	5A & B
41	5.25	5A & B
42	5.25	5A & B

Height (in.)	Center Distance	Links to use
43	5.56	5A & B
44	5.25	5A & B
45	5.25	5A & B
46	5.25	5A & B
47	5.25	5A & B
48	5.25	5A & B
49	5.25	5A & B
50	5.25	5A & B
51	5.25	5A & B
52	5.25	5A & B
53	5.25	5A & B
54	5.56	5A & B
55	5.25	5A & B
56	5.25	5A & B
57	5.25	5A & B
58	5.25	5A & B
59	5.25	5A & B
60	5.25	5A & B
61	5.25	5A & B
62	5.25	5A & B
63	5.25	5A & B
64	5.25	5A & B
65	5.56	5A & B
66	5.25	5A & B
67	5.25	5A & B
68	5.25	5A & B
69	5.25	5A & B
70	5.25	5A & B
71	5.25	5A & B
72	5.25	5A & B
73	5.25	5A & B
74	5.25	5A & B



Installation cont....

6. Remove the E-clip from the linkage pin on the bottom blade and install the connecting link assembly with the longest link towards the blade. Reinstall the E-clip onto linkage pin.
7. Place bottom end of connecting link assembly onto the ¼ in. (6mm) diameter pin (item # 11) extending from APC assembly crankarm (item# 4). Secure with E-clip (see item #14).

Adjustment

Manually open blades without tension on the adjustment spring. The crankarm should hit bottom inside the APC bracket with blades open. The APC lever exerts a force up, or towards the blades to resist their opening. If the crankarm strikes the bracket before the blades are open, loosen the ¼-20 threadstuds and adjust the center distance of the connecting link assembly, using slotted holes. Retighten.

Adjust set pressure by pulling back the release rod (item #3) and rotating the knob (item #2) counterclockwise to increase tension. Let go of the release rod to lock the knob in place.

Dimensions

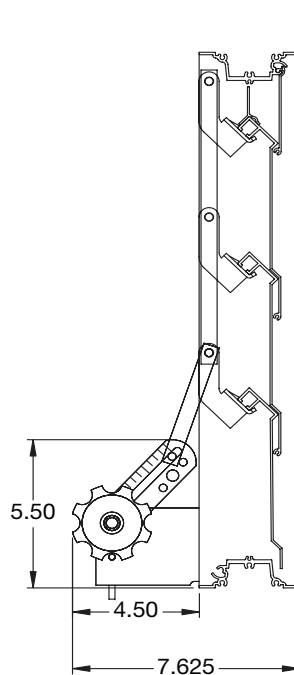

Installation and Adjustment Video



[APC Video](#)

