

Installation, Operation and Maintenance Manual

Please read and save these instructions for future reference. Read carefully before attempting to assemble, install, operate or maintain the product described. Protect yourself and others by observing all safety information. Failure to comply with these instructions will result in voiding of the product warranty and may result in personal injury and/or property damage.



Receiving and Handling

Upon receiving dampers, check for both obvious and hidden damage. If damage is found, record all necessary information on the bill of lading and file a claim with the final carrier. Check to be sure that all parts of the shipment, including accessories, are accounted for.

Dampers must be kept dry and clean. Indoor storage and protection from dirt, dust and the weather is highly recommended. Do not store at temperatures in excess of 100°F (38°C).

Safety Warning

Improper installation, adjustment, alteration, service or maintenance can cause property damage, injury or death. Read the installation, operating, and maintenance instructions thoroughly before installing or servicing this equipment.

Table of Contents

Pre-Installation Guidelines	2
Multi-Section Assembly	3
Counterbalance Adjustment	4-7
EM/GM-30, 31, 32	4-5
EM-10, 11, 12	6
EM-40, 41, 42	7

Pre-Installation Guidelines

The basic intent of a proper installation is to secure the backdraft damper into the opening in such a manner as to prevent distortion and disruption of damper operation. The following items will aid in completing the damper installation in a timely and effective manner.

- 1) Check the schedules for proper damper locations within the building. Visually inspect the damper for damage.
- 2) Lift or handle damper using sleeve or frame. Do not lift damper using blades and linkage. When handling multiple sections assemblies, use sufficient support to evenly lift at each section mullion (see drawing). Do not drag, step on, apply excessive bending, twisting, or racking.

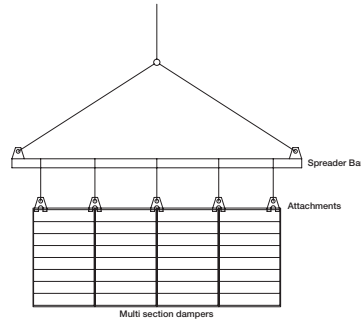

- 3) Do not install screws in damper frame that will interfere with unexposed blade linkage and prevent damper blades from opening and/or closing.
- 4) Damper must be installed into duct or opening square and free of twist or other misalignment. Damper must not be squeezed or stretched into duct or opening. Out of square, racked, twisted or misaligned installations can cause excessive leakage and/or torque requirements to exceed damper/actuator design.
- 5) Damper must be kept clean, dry and protected from dirt, dust and other foreign materials prior to and after installation. Examples of such foreign materials include but are not limited to:
 - a) Mortar dust
 - b) Drywall dust
 - c) Firesafing materials
 - d) Wall texture
 - e) Paint overspray
- 6) Damper should be sufficiently covered as to prevent overspray if wall texturing or spray painting will be performed within 5 feet (1.50m) of the damper. Excessive dirt or foreign material deposits on damper can cause excessive leakage and/or torque requirements to exceed damper design.
- 7) ACCESS: Suitable access (actuators maintenance, etc.) must be provided for damper inspection and servicing. Where it is not possible to achieve sufficient size access, it will be necessary to install a removable section of duct.
- 8) Applications where airflow could be uneven, such as a discharge fan, it is imperative to verify that at no point the maximum velocity exceeds the damper cataloged velocity.

Installation

1) Dampers ordered with "nominal" sizing are undersized 1/4 in. (6mm) to facilitate ease of installation. For example, a 12 in. x 12 in. (305mm x 305mm) nominal damper will measure 11 3/4 in. x 11 3/4 in. (298mm x 298mm). Dampers ordered with "actual" sizing are not undersized. The duct or barrier opening that the damper is being mounted in should be 1/4 in. (6mm) larger than the damper dimensions in both width and height. The opening should also be straight and level (**Figure 1**).

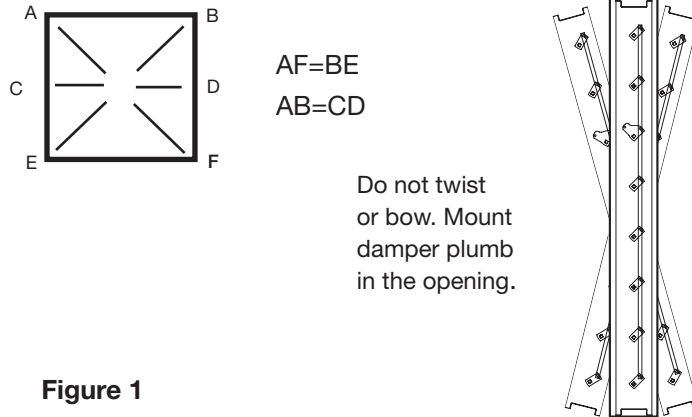
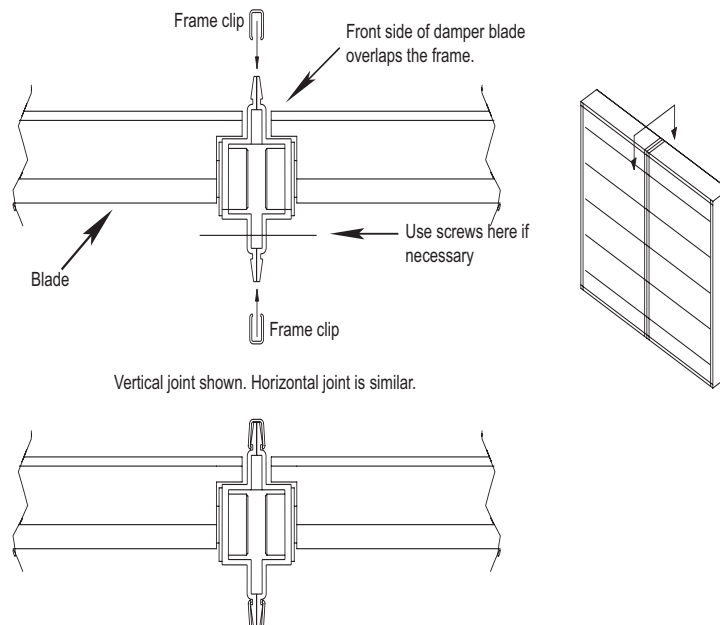

Figure 1

2) All installations require the entire exterior perimeter of the damper assembly to be secured to structural supports (example: concrete block wall, structural steel, etc.) which is supplied by others. The fastening method used to secure the damper to the structural support and the design of the structural support is the responsibility of field engineers.

Multi-Section Assembly

When the finished damper assembly is made up of multiple sections, the sections will require field assembly. Frame clips are provided for this purpose. The frame clips are a snap fit component that fit over the joint between adjoining sections. The clips will require the use of a rubber hammer of similar tool to install as shown below. Install frame clips on the front side and backside of the assembly. For added strength, screws may be used on the backside of the frames in lieu of or in addition to the frame clip. Do not install screws on the front side of the frame where they could interfere with the operation of the blades. **Note: Used only on EM series dampers. Structural support reinforcement to be provided by others.**



Counterbalance Adjustment Procedure

The following instructions should be followed when attempting to maximize the counterbalance effect on the EM or GM model dampers. Be aware that when the balance setting is highly sensitive, friction wear, and contamination will have an adverse effect to the operation of the damper. The sensitivity of the counterbalance should only be set to meet the application requirements. The damper must be mounted square and plumb and operate freely before any weight adjustments are performed.

Counterbalance Adjustment for EM/GM-30, 31, and 32: Vertical Mount - Horizontal Airflow

There are two different adjustments that can be made:

Adjustment #1: affects the balance of the blades in the open position. Use this adjustment method if the damper blades do not achieve full open position under airflow and you want them to open further or all the way.

Adjustment #2: affects the balance of the blades in the closed position along with a small change to the open position balance.

If the airflow through the damper is light and the blades only slightly move from the closed position, then Adjustment #1 and #2 are required.

Adjustment #1: Balance the Blades in the Open Position

Moving the weight stack along the length of the mounting bracket slot will affect the full open balance of the blade assembly. Moving the weights further away from the blade pivot point will cause the blades to become more balanced so that at some point, and with enough weight, the blades would remain open. Care must be taken to ensure that when the weights are moved outward from the blade pivot point they will not interfere with the adjacent blade when the blades close. Moving the weights back towards the blade pivot point will allow the blades to close. If the damper blades do not open completely and Adjustment #1 has been addressed, then more weight(s) is required.

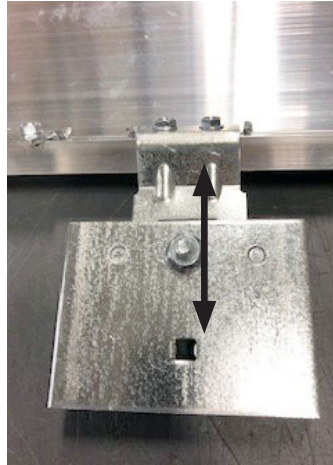

Adjustment #2: Balance the Blades in the Closed Position

The damper is assembled with the counterbalance weights and bracket installed such that, when the blades are closed, the counterbalance weights and bracket are positioned directly in-line with the blade pivot points. This position of the weights will provide a light load that will hold the blades in the closed position. To reduce this load, the counterweight mounting brackets can be bent away from the adjacent blade surface. Bending the counterweight mounting brackets will move the counterweight stack behind the blade pivot point and therefore allow the blades to start opening at lower airflow rates. This adjustment should be performed in small increments since the blades will not fully close if the brackets are bent too far.



Bend counterweight mounting bracket away from blades.

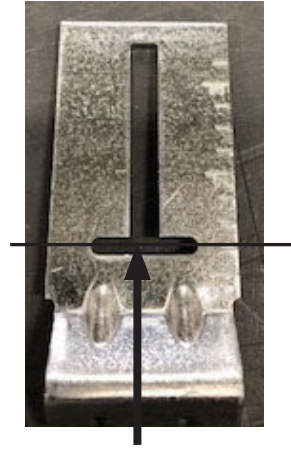

Bend Here

Counterbalance Adjustment for EM-10, 11, and 12: Horizontal Mount-Vertical Airflow Up

There are two different adjustments that can be made:

Adjustment #1: affects the balance of the blades in the closed position along with a small change to the open position balance.

Adjustment #2: affects the balance of the blades in the open position. Use this adjustment method if the damper blades do not achieve full open position under airflow and you want them to open further or all the way.

If the airflow through the damper is light and the blades only slightly move from the closed position, then Adjustment #1 is required. If the airflow through the damper is light and the blades do not reach full open position, then Adjustment #2 may be excessive or Adjustment #1 may need to be increased or both adjustments may need to be addressed.

Adjustment #1: Balance the Blades in the Closed Position

Moving the weight along the length of the mounting bracket slot will affect the full closed balance of the blade assembly. Moving the weights further away from the blade pivot point will cause the blades to become more balanced so that at some point, and with enough weight, the blades will remain open without air pressure being applied. Care must be taken to ensure that when the weights are moved away from the blade pivot point, the weights do not interfere with the adjacent blade when the blades close. Moving some of the weights back towards the blade pivot point will allow the blades to return to the closed position.



Adjustment #2: Balance the Blades in the Open Position

The damper is factory assembled with the counterbalance assembly installed such that, the counterbalance weights and bracket are positioned at a slight angle to the surface of the blade. This angle will position the weights such that they will provide a slight load that will cause the blades to rotate from the full open position toward the closed position. If for some reason the blades remain in the open position then you will need to increase this load. To do this the counterweight mounting brackets should be bent further away from the blade surface. Bending the counterweight mounting brackets will move the counterweight stack away from the blade surface and therefore the torsion effect will force the blades to start closing. This adjustment should be performed in small increments to each weight bracket.

Counterbalance Adjustment for EM-40, 41, 42: Horizontal Mount - Vertical Airflow Down

There are two different adjustments that can be made:

Adjustment #1: affects the balance of the blades in the closed position along with a small change to the open position balance.

Adjustment #2: affects the balance of the blades in the open position. Use this adjustment method if the damper blades do not achieve full open position under airflow and you want them to open further or all the way.

If the airflow through the damper is light and the blades only slightly move from the closed position, then Adjustment #1 is required.

Adjustment #1: Balance the Blades in the Closed Position

Moving the weight along the length of the mounting bracket slot will affect the full closed balance of the blade assembly. Moving the weights closer to the blade pivot point will cause the blades to become less balanced so that at some point the blades would fall open. Care must be taken to ensure that when the weights are moved outward from the blade pivot point the weights will not interfere with the adjacent blade when the blades close. Moving some of the weights back towards the blade pivot point will force the blades to close properly. If the damper blades do not close completely and Adjustment #1 has been addressed, then more weight is required.

Adjustment #2: Balance the Blades in the Open Position

The damper is factory assembled with the counterbalance weights and bracket installed such that, when the blades are closed, the counterbalance weights and bracket are positioned directly in-line or slightly ahead of the blade pivot points. The position of the weights will provide a slight load that will cause the blades to rotate from the full open position toward the closed position. To increase this load, the counterweight mounting brackets can be bent toward the adjacent blade surface. Bending the counterweight mounting brackets will move the counterweight stack which will force the blades to start closing. This adjustment should be performed in small increments to each weight bracket since bending the brackets too much cause the weight stack to interfere with the adjacent blade surface.

Counterbalance Weight Adjustment Procedure Video



[Counterbalance Weight Adjustment Video](#)

