

Installation, Operation and Maintenance Manual

Please read and save these instructions for future reference. Read carefully before attempting to assemble, install, operate or maintain the product described. Protect yourself and others by observing all safety information. Failure to comply with these instructions will result in voiding of the product warranty and may result in personal injury and/or property damage.



Table of Contents

General Information	1
Pre-Installation Guidelines	2
Counterweight Adjustment Procedure.	3-6
• Counterbalance Adjustment for BR-1x series . . .	4
• Counterbalance Adjustment for BR-3x series . . .	5
• Counterbalance Adjustment for BR-4x series . . .	6
Damper Maintenance	7

Receiving and Handling

Upon receiving dampers, check for both obvious and hidden damage. If damage is found, record all necessary information on the bill of lading and file a claim with the final carrier. Check to be sure that all parts of the shipment, including accessories, are accounted for.

Dampers must be kept dry and clean. Indoor storage and protection from dirt, dust and the weather is highly recommended. Do not store at temperatures in excess of 100°F (38°C).

Safety Warning

Improper installation, adjustment, alteration, service or maintenance can cause property damage, injury or death. Read the installation, operating, and maintenance instructions thoroughly before installing or servicing this equipment.

Pre-Installation Guidelines

The basic intent of a proper installation is to secure the damper into the opening in such a manner as to prevent distortion and disruption of damper operation. The following items will aid in completing the damper installation in a timely and effective manner.

- 1) Check the schedules for proper damper locations within the building. Visually inspect the damper for damage.
- 2) Lift or handle damper using sleeve or frame. Do not lift damper using blades or linkage. When handling multiple section assemblies, use sufficient support to evenly lift at each section mullion (see **Figure 1**). Do not drag, step on, apply excessive bending, twisting, or racking.

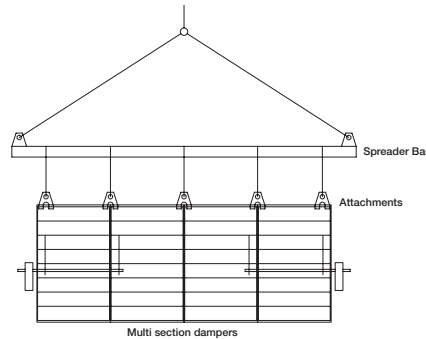

Figure 1- Supports for lifting a multi-section damper

- 3) Do not install screws in damper frame that will interfere with damper blades and prevent them from opening and/or closing.
- 5) Damper must be installed into duct or opening square and free of twist or other misalignment. Damper must not be squeezed or stretched into the duct opening. Out of square, racked, twisted or misaligned installations can cause excessive leakage and/or prevent free operation.
- 6) Damper and actuator must be kept clean and protected from dirt, dust and other foreign materials prior to and after installation. Examples of such foreign materials include but are not limited to:
 - a) Mortar dust
 - b) Drywall dust
 - c) Firesafing materials
 - d) Wall texture
 - e) Paint overspray
- 7) Damper should be sufficiently covered as to prevent overspray if wall texturing or spray painting will be performed within 5 feet of the damper.
- 8) Applications where airflow could be uneven, such as a discharge fan, it is imperative to verify that at no point the maximum velocity exceeds the damper cataloged velocity.

Counterweight Adjustment Procedure for BR Models

Dampers are shipped from the factory with the frame flange location and flow direction as ordered. Location and size of both counterbalances (blade edge, adjustable blade weights) are dependent upon the flow direction and damper size. The damper must be mounted square and plumb and must operate freely before any weight adjustments are performed. Contact Greenheck for required modifications to change the flow directions.

The following instructions should be followed when attempting to adjust counterweights on the BR series dampers. **Figure 2, 2A, and 2B** shows the typical location of the adjustable counterweight assembly. Depending on the size of the damper and specified start open pressure, the damper may have more than one counterweight assembly.

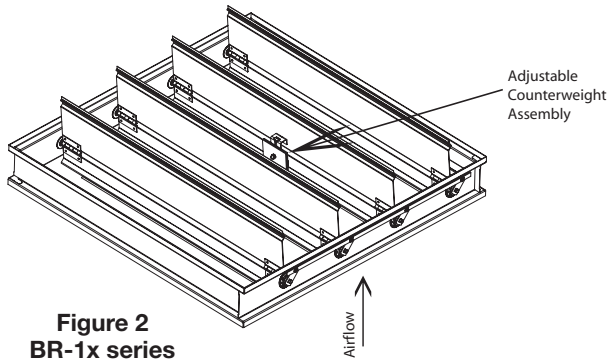

Figure 2
BR-1x series

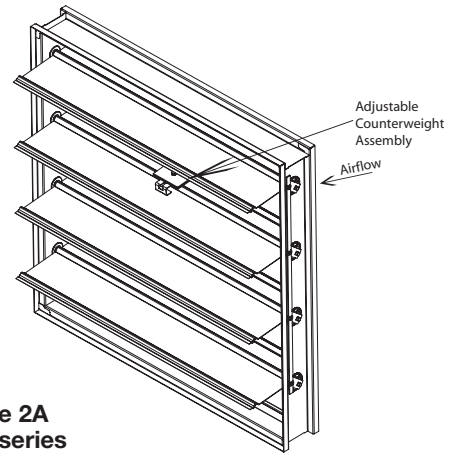

Figure 2A
BR-3x series

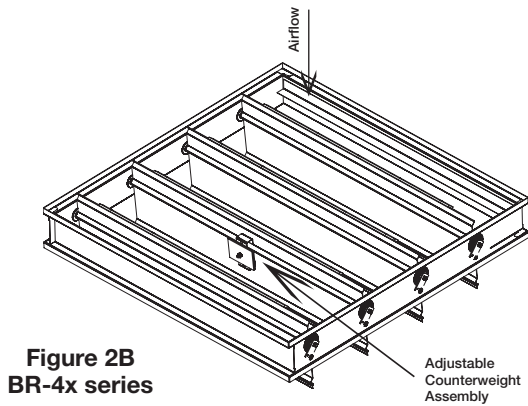

Figure 2B
BR-4x series

Counterbalance Adjustment for BR-1x Series: Horizontal Mount - Vertical Up Airflow

Figures 3 & 4 show the components of a typical adjustable counterweight assembly. BR-1X series damper with a short height may have a different style blade and a trimmed mounting bracket. The adjustment procedure is the same for both styles of blades.

The blade edge counterweight (Figure 4) is factory set and not intended for field adjustment. For vertical up airflow, all adjustments should be made in the adjustable counterweight assembly.

When adjusting the counterbalance weights, you will need to adjust the full open pressure and start open pressure.

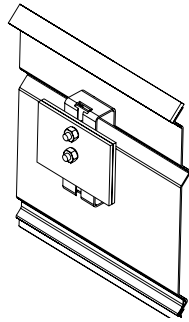

Figure 3 Adjustable counterweight assembly

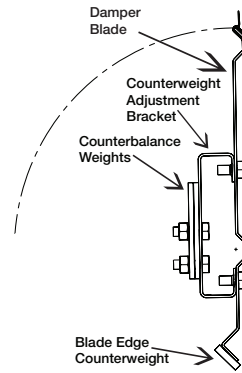

Figure 4 - Adjustable counterweight assembly detail

Adjusting Full Open Pressure with Closing Force

Adjusting the closing force will also affect the full open pressure. Figure 4 shows the blade in the full open position. Additional weights can be added to increase the closing force. Removal or trimming of weight will reduce the closing force. After adjustment, verify blades close under no airflow from the full open position. Increase the closing force if the blades fail to close.

Adjusting Start Open Pressure

When the blades are in the closed position, the adjustable weights are used for the start open pressure of the damper. Sliding the weights toward the blade seal will increase the start open pressure and sliding the weights toward the blade edge counterweight will decrease pressure. (Figure 5)

If sliding the weights to the furthest left position (toward the blade seal) does not provide a high enough start open pressure, additional weights can be added. In this case, the closing force will also increase.

Dampers are factory adjusted to the start open pressure, based upon your order, for the specified flow direction. Typically, a minimum of one weight plate will be used to keep blades closed, although only the mounting bracket may be sufficient for small damper sizes. Consult factory for plate quantity and sizing if an elevated start open pressure is required.

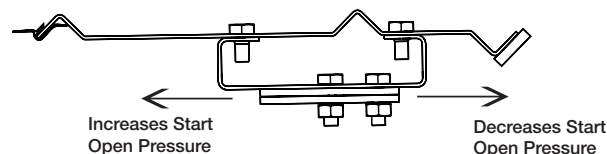

Figure 5: Counterweight adjustment for start open pressure. Blade is shown in full close position

Final Adjustment Check

After adjusting the counterweights, verify that no interference occurs between the counterweights and the adjustment blades. If any interference, adjust counterweights. Also verify that the damper blades close under no airflow from the full open, $\frac{1}{2}$ open, and $\frac{1}{4}$ open positions. If blades do not close, adjust the weights as required.

Counterbalance Adjustment for BR-3x Series: Vertical Mount - Horizontal Airflow

Figure 6 details the components of a typical adjustable counterweight assembly. Dampers with a short height may have a different style blade and a trimmed mounting bracket. The adjustment procedure is the same for both styles of blades.

The blade edge counterweight (**Figure 6**) is factory set and not intended for field adjustment. For horizontal airflow, all adjustments should be made in the adjustable counterweight assembly.

When adjusting the counterbalance weights, you will need to adjust the full open pressure and start open pressure. Both steps will need to be done.

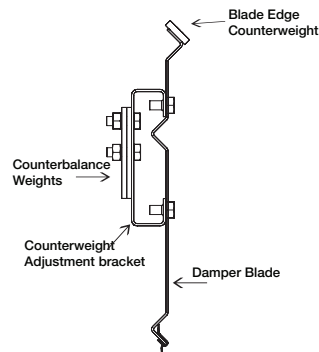

Figure 6 - Adjustable counterweight assembly detail

Adjusting Start Open Pressure

When the blades are in the closed position (**Figure 6**), the adjustable weight are used for the start open pressure of the damper. Additional weights can be added to increase start open pressure and removal or trimming of weights will reduce start open pressure. After adjustment, verify blades close under no airflow from the $\frac{1}{4}$ open position. If the blades fail to close, additional weight is required.

Adjusting Full Open Pressure and Closing Force

Adjusting the closing force will also affect the full open pressure. **Figure 7** shows the blade in the full open position. If blades hang open or more closing force is desired, slide weights toward the bottom of the bracket. If the blades close too fast or less closing force is desired, move weight toward the top of the bracket.

Dampers are factory adjusted to the start open pressure, based upon your order, for the specified flow direction. Typically, a minimum of one weight plate will be used to keep blades closed, although only the mounting bracket may be sufficient for small damper sizes. Consult factory for plate quantity and sizing if an elevated start open pressure is required.

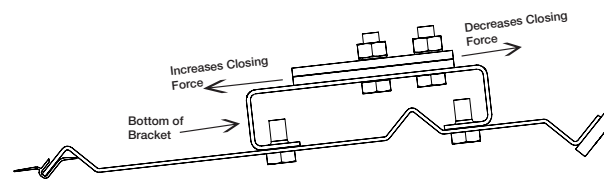

Figure 7: Counterweight adjustment in the full open position

Final Adjustment Check

After adjusting the counterweights, verify that no interference occurs between the counterweights and the adjacent blades. If any interference, adjust counterweights. Also verify that the damper blades close under no airflow from the full open, $\frac{1}{2}$ open, and $\frac{1}{4}$ open positions. If blades do not close, adjust weights as required.

Counterbalance Adjustment for BR-4x Series: Vertical Mount - Horizontal Airflow

Figure 8 details the components of a typical adjustable counterweight assembly. Dampers with a short height may have a different style blade and a trimmed mounting bracket. The adjustment procedure is the same for both styles of blades.

The blade edge counterweight (**Figure 8**) is factory set for the specified start open pressure. For vertical down airflow, minor adjustments can be made in the adjustable counterweight assembly, then changes to the blade edge weight would be required. Consult factory for assistance in adjusting blade edge weight.

When adjusting the counterbalance weights, you will need to adjust the full open pressure and start open pressure. Both steps will need to be done.

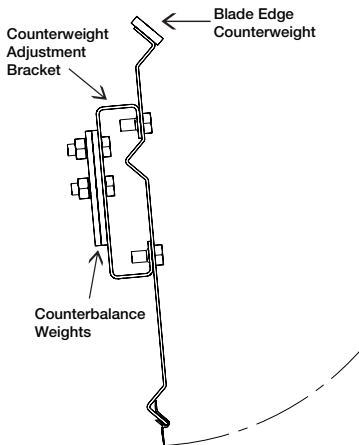

Figure 8 - Adjustable counterweight assembly detail

Adjusting Full Open Pressure and Closing Force

Adjusting the closing force will also affect the full open pressure. **Figure 8** shows the blade in the full open position. Additional weights can be added to increase the closing force. Removal or trimming of weights will reduce the closing force. After adjustment, verify the blades close under no airflow from the full open position. Increase the closing force if the blades fail to close.

Adjusting Start Open Pressure

When the blades are in the closed position, the adjustable weights are used for the start open pressure of the damper. Sliding the weights toward the blade edge counterweight will increase the start open pressure and sliding the weights toward the blade seal will decrease pressure (**Figure 9**).

If sliding the weights to the furthest left position (toward the blade edge counterweight) does not provide a high enough start open pressure, additional weight to the blade edge counterweight would be required.

Dampers are factory adjusted to the start open pressure, based upon your order, for the specified flow direction. Typically, a minimum of one weight plate will be used to keep blades closed, although only the mounting bracket may be sufficient for small damper sizes. Consult factory if an elevated start open pressure is required.

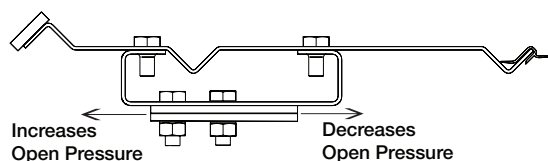

Figure 9: Counterweight adjustment for start open pressure. Blade is shown in full close position.

Final Adjustment Check

After adjusting the counterweights, verify that no interference occurs between the counterweights and the adjacent blades. If any interference, adjust counterweights. Also verify that the damper blades close under no airflow from the full open, $^{\circ}$, and $\frac{1}{4}$ open positions. If blades do not close, adjust weights as required.

