

Assembly Instructions

PARTS LIST

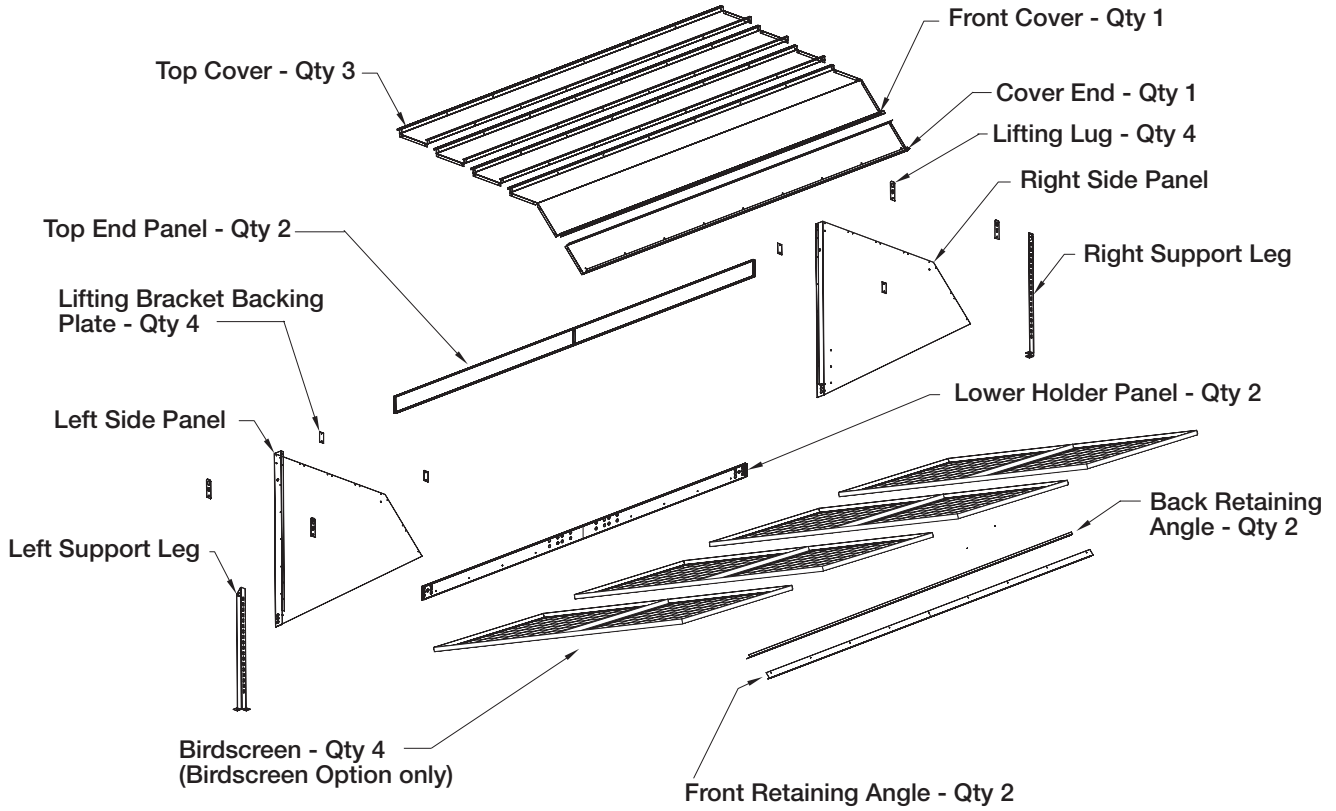

PARTS REQUIRED WITH FILTER OPTION

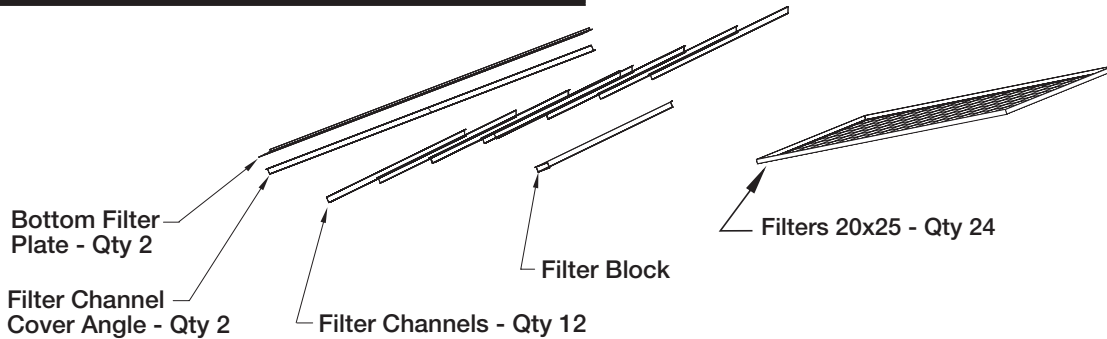

TOOLS REQUIRED

- 9/16 in. wrench
- 5/16 in. nut driver
- Pop Rivet Gun (*filter option only*)

HARDWARE KIT

Description	Quantity
Hex Head Bolts (3/8 in. x 3/4 in.)	4
Head Nut (3/8 in.)	4
Sheet Metal Screws (12 x .625)	115
Thread Cutting Screw (3/8 in. x 1 in.)	4
Pop Rivets (3/16 in. x 1/8 - 1/4) filter option only	30

STEP 1

- A. Fasten Left and Right sections of Top End Panel together using sheet metal screws.
- B. Fasten Top End Panel to Left and Right Side Panels using sheet metal screws.
- C. Fasten (2) Lower Holder Panel sections to Left and Right Side Panels using sheet metal screws.
- D. Fasten the Left and Right Legs to the Left and Right Side Panels using the 3/8 in. bolts and 3/8 in. nuts provided.

The weatherhood may be completely assembled before completing Step 1D.

- E. Fasten Holder Panel and Left and Right Side Panels to the TSU unit with sheet metal screws.

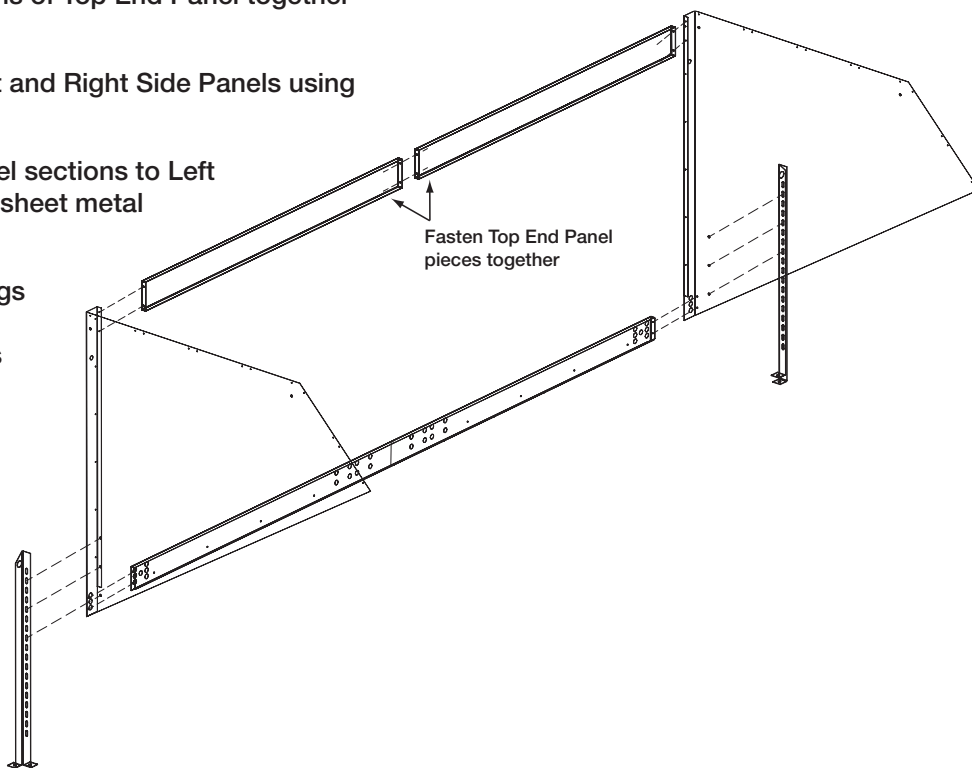

STEP 2

- A. Fasten (3) Cover sections together using sheet metal screws.
- B. Fasten the Front Cover section to the assembled Cover section using sheet metal screws.
- C. Fasten the Cover End section to the Front End Cover and Cover assembly using sheet metal screws.
- D. Screw Top of Covers together along seams of the Side Panels using sheet metal screws.

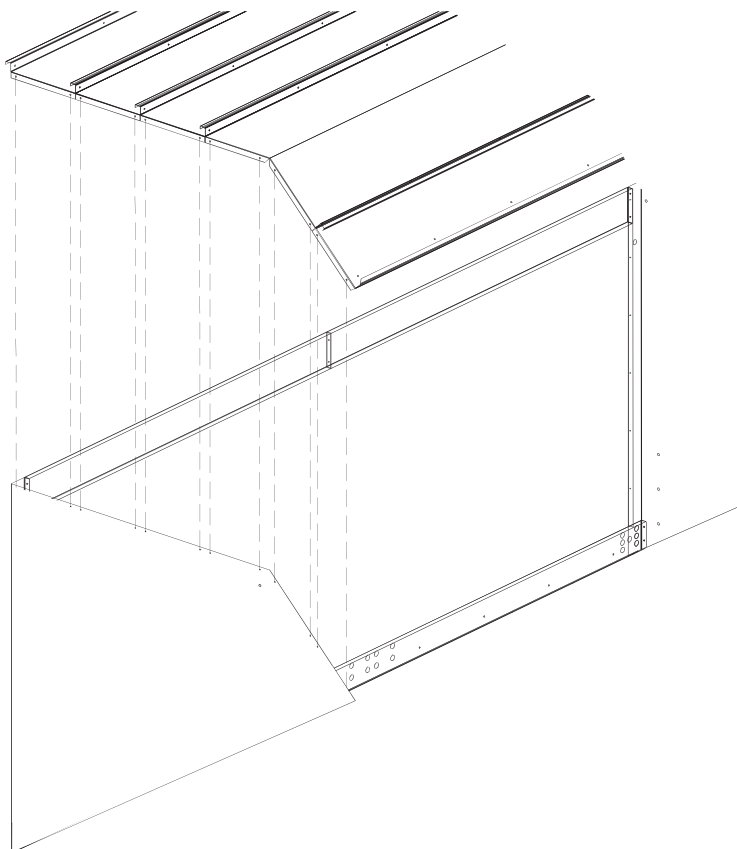

STEP 3

- A. Fasten (4) Lifting Lugs to Left and Right Side Panels with (4) 3/8 in. x 1 in. thread cutting screws and (4) Lifting Lug Backers.
- B. Fasten (2) Front and (2) Back Retaining Angle sections to the Cover End with sheet metal screws as shown in the bubble.

For the filter option, go to Step 4

- C. Slide (4) Birdscreen sections up between Front and Back Retaining Angles. Then slide bottom of (4) Birdscreens into Lower Holder Panel. If you are going to attach weatherhood to unit after assembly, complete this step after the weatherhood is fastened to the unit.

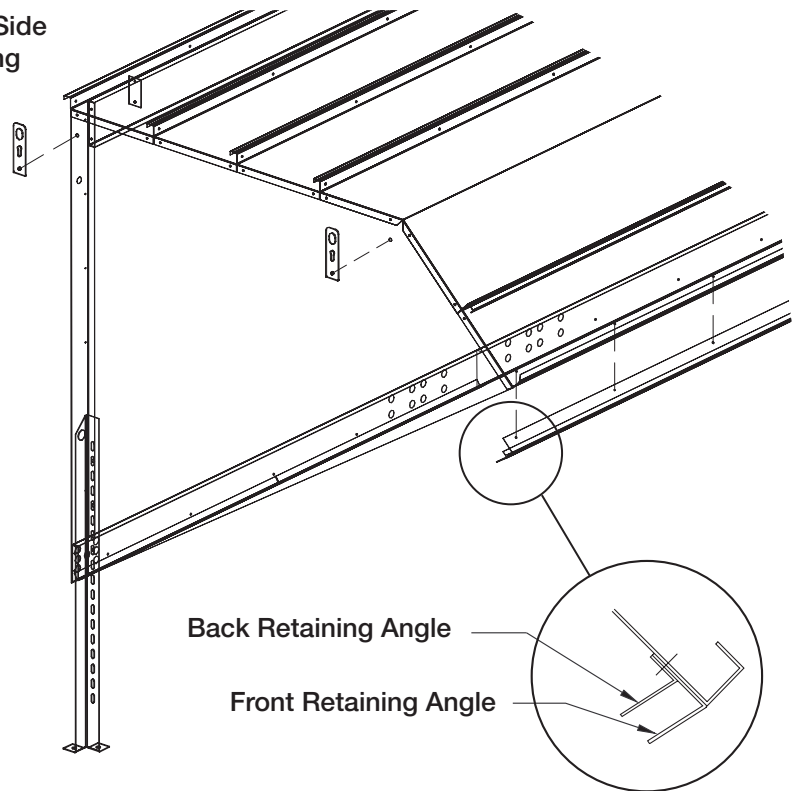

STEP 4

- A. Fasten (2) Bottom Filter Plate sections to Lower Holder Panel with sheet metal screws.

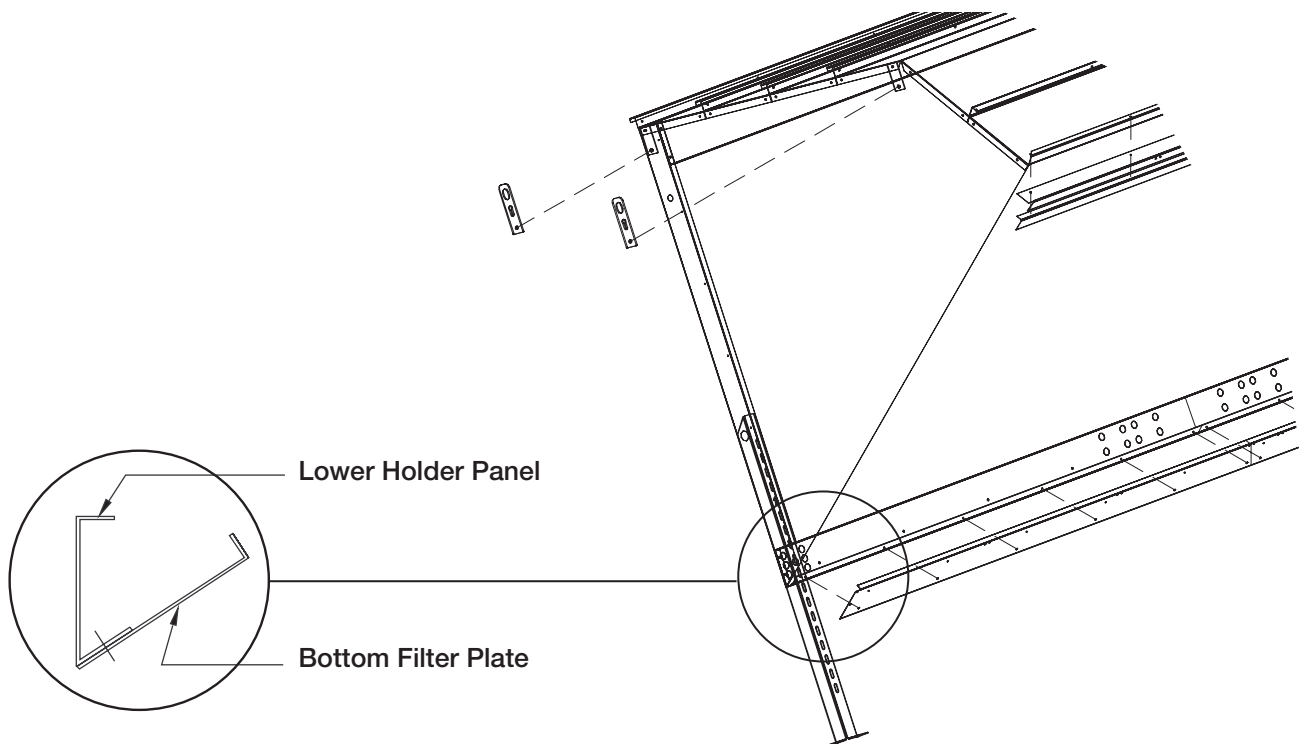

STEP 5

- A. Fasten (6) Right and (6) Left Filter Channel pieces and the Filter Block to the Front Retaining Angle and Bottom Filter Plate with pop rivets.
- B. Fasten (2) Filter Channel Cover sections to the Bottom Filter Plate with sheet metal screws, securing the bottom of the Filter Channels.
- C. Slide Filters down into the filter channels. This does not require any fasteners.

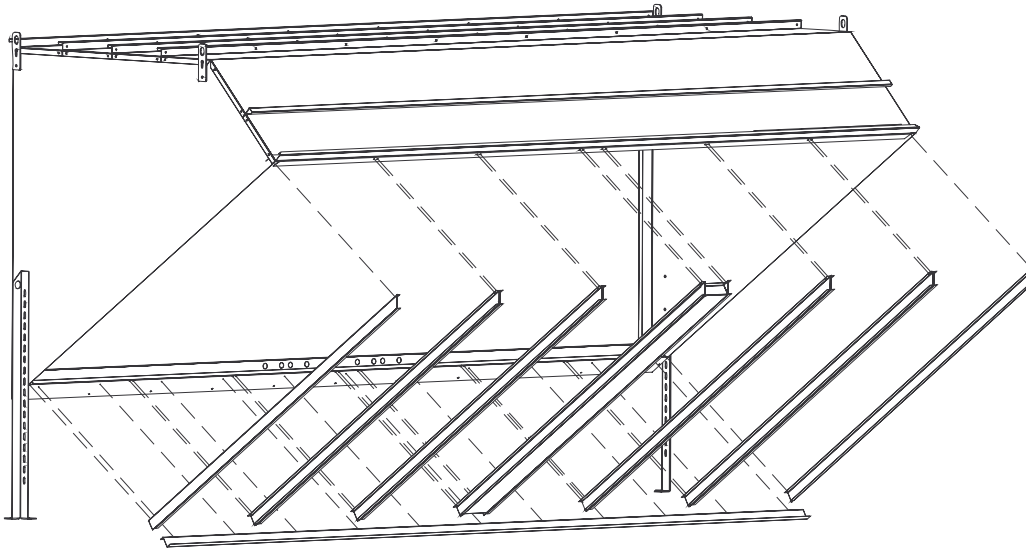

FILTER CHANNEL ASSEMBLY

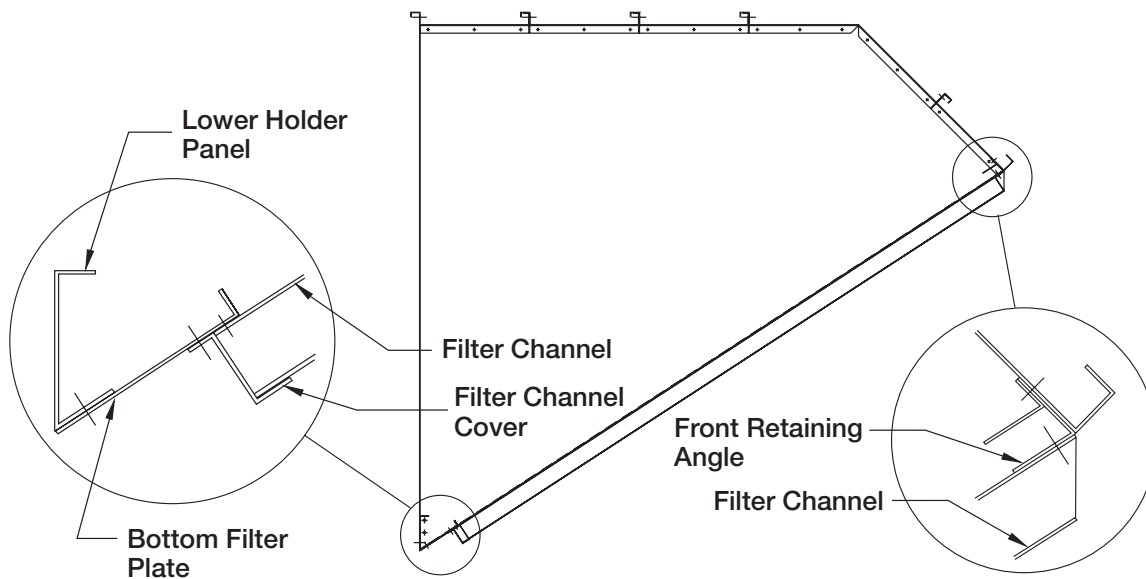

Contact Greenheck Fan Corporation:

Phone: (715) 359-6171 • Fax: (715) 355-2399 • E-mail: gfcinfo@greenheck.com • Website: www.greenheck.com

