

Installation, Operation and Maintenance Manual

Please read and save these instructions for future reference. Read carefully before attempting to assemble, install, operate or maintain the product described. Protect yourself and others by observing all safety information. Failure to comply with these instructions will result in voiding of the product warranty and may result in personal injury and/or property damage.

Fabra Hood Gravity Ventilator

Multi-Section with birdscreen, throat length greater than 72 inches

Fabra hood gravity ventilators are designed for intake (model FGI) or relief (model FGR) applications with natural gravity or negative pressure systems. Units feature a low-silhouette, fabra hood-style housing offering superior load bearing strength, weather-resistance, dimensional flexibility and appearance.



General Safety Information

Only qualified personnel should install this unit. Personnel should have a clear understanding of these instructions and should be aware of general safety precautions. Improper installation can result in electric shock, possible injury due to coming in contact with moving parts, as well as other potential hazards. Other considerations may be required if high winds or seismic activity is present. If more information is needed, contact a licensed professional engineer before moving forward.

Receiving

Upon receiving the product check to ensure all items are accounted for by referencing the delivery receipt or packing list. Inspect each crate or carton for shipping damage before accepting delivery. Alert the carrier of any damage detected. The customer will make a notation of damage (or shortage of items) on the delivery receipt and all copies of the bill of lading which is countersigned by the delivering carrier. If damaged, immediately contact your local representative. Any physical damage to the unit after acceptance is not the responsibility of the manufacturer.

Unpacking

Verify that all required parts and the correct quantity of each item have been received. If any items are missing, report shortages to your local representative to arrange for obtaining missing parts. Due to availability of transportation and truck space all items for the unit may not be shipped together. Confirmation of shipment(s) must be limited to only items on the bill of lading.

Handling

Lifting the units must be done with care to avoid damaging the housing. Fabra hood gravity ventilators are to be rigged and moved by the optional lifting brackets provided or by the skid when a forklift is used. Location of brackets varies by model and size. Handle in such a manner as to keep from scratching or chipping the coating (if applicable). Damaged finish may reduce the ability of the ventilator to resist corrosion.

Standard Assembly

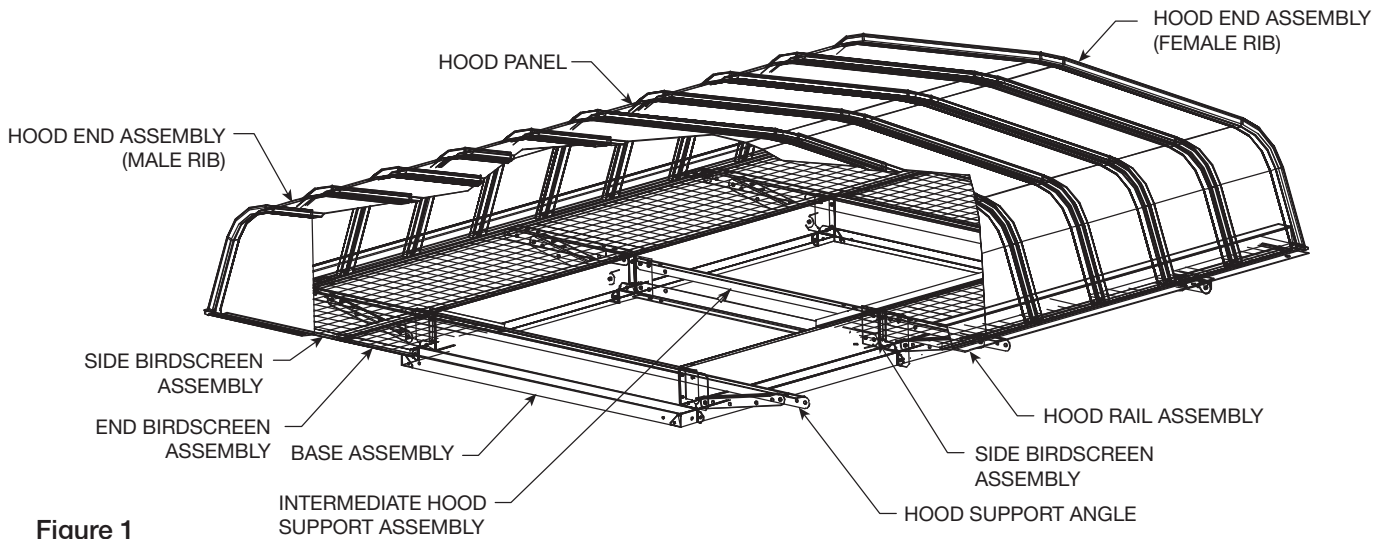

Figure 1

Step 1

Open the shipping crates and separate the parts according to the size of the unit, refer to Figure 1.

Step 2

Place the two base ends, base sides and intermediate hood support assembly in their approximate relationship to each other, see Figure 2. Fasten together the base ends to the base sides using three 1/4-20 fasteners per corner for 5 inch high base and four 1/4-20 fasteners per corner for 12 inch high base.

NOTE: Fasteners should be hand tightened only until Step 4.

On some units where the difference between the hood width and throat width is greater than 32 inches, a reinforcing plate is required in the corners of the base, see Figure 2, Detail A. Bolt the base sides to the intermediate assembly, using eight 1/4-20 fasteners per intermediate assembly for 5 inch base and ten 1/4-20 fasteners for 12 inch high base.

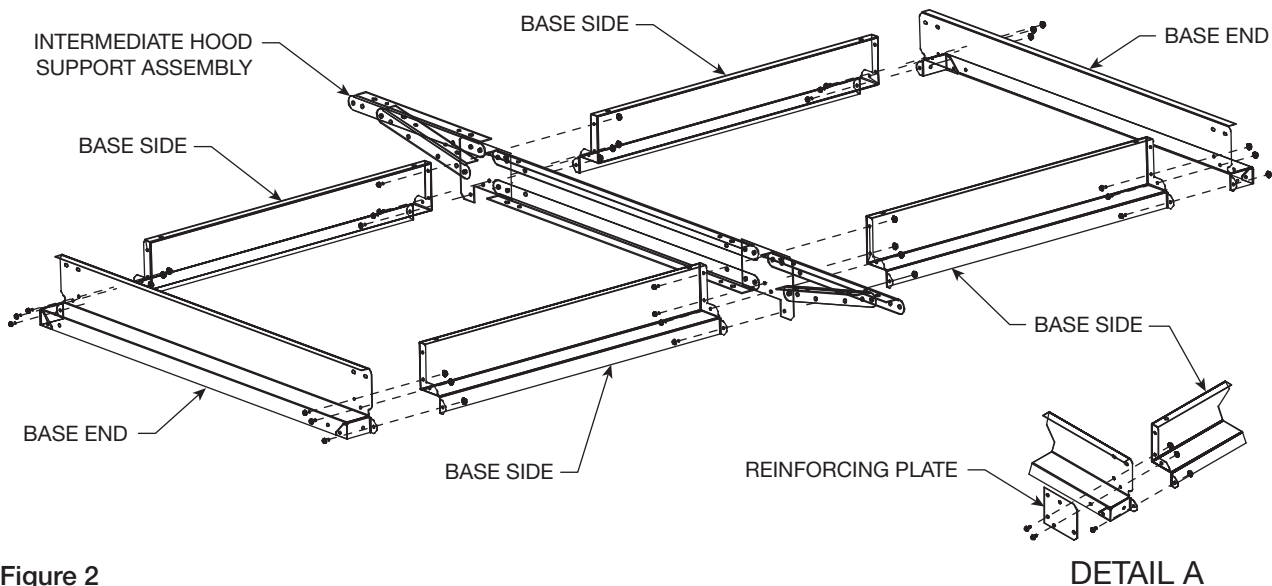

Figure 2

Step 3

Attach the hood support angle to the base assembly (hand tight) using four 1/2-20 fasteners per angle, see Figure 3, Detail B.

On some units, two diagonal braces come pre-attached to the hood support angle. Fasten the loose end of the diagonal braces to the base assembly using one 1/4-20 fastener per diagonal brace. See Figure 3, Detail C.

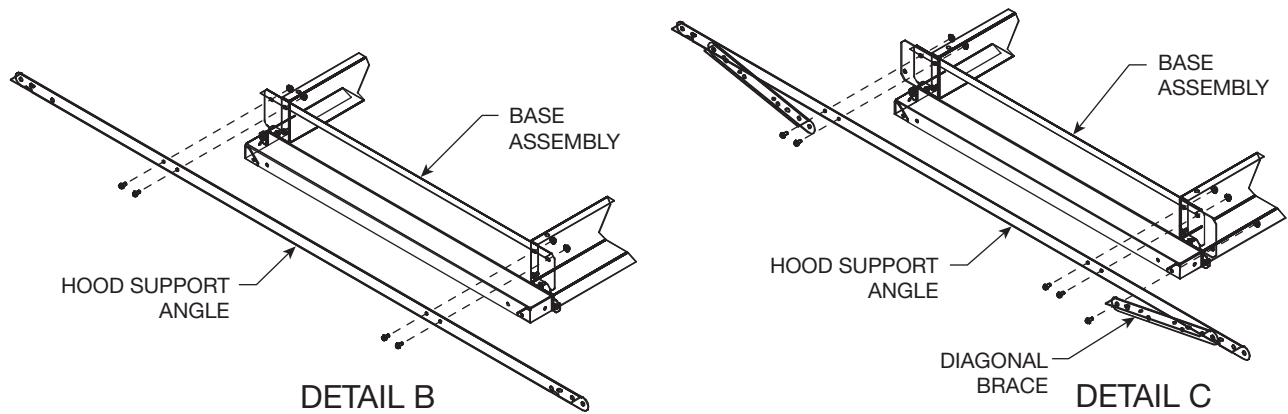

Figure 3

Step 4

Tighten all fasteners. Caulk all inside corners where the base sections come together. At this point the base may be lifted onto the roof curb before proceeding with further assembly.

Step 5

Bolt together the side birdscreen assembly left to the side birdscreen assembly right, using two 1/4-20 fasteners per side birdscreen assembly, see Figure 4.

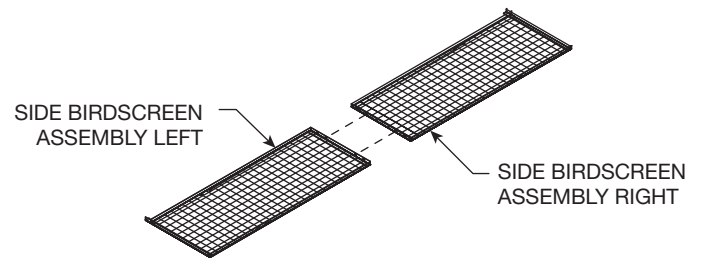

Figure 4

Step 6

Attach the side birdscreen assembly to the hood support angle and base assembly using four 1/4-20 X 1 inch fasteners per screen assembly, see Figure 5.

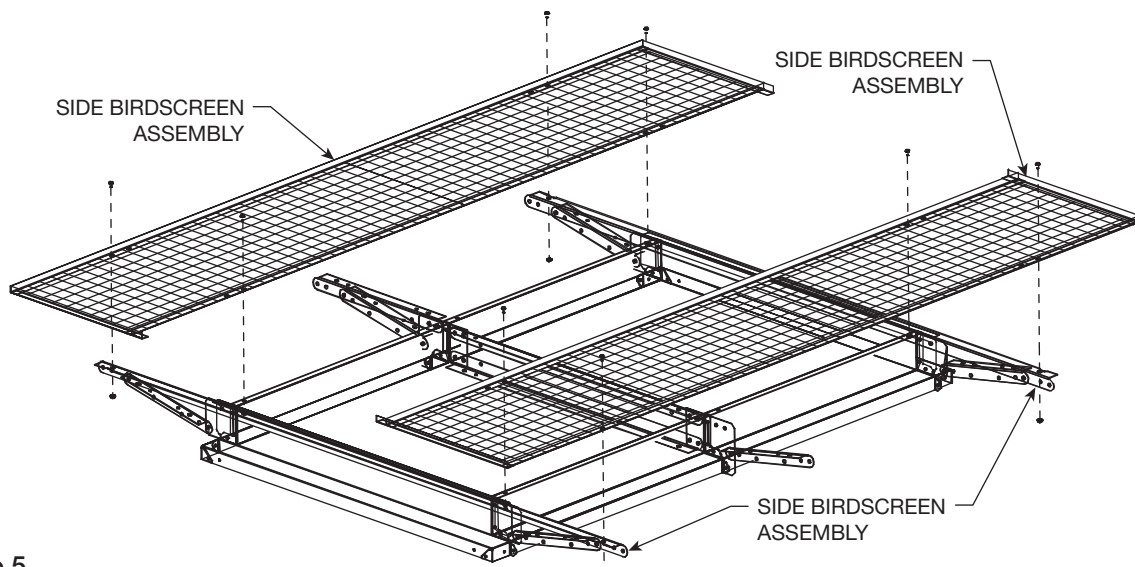
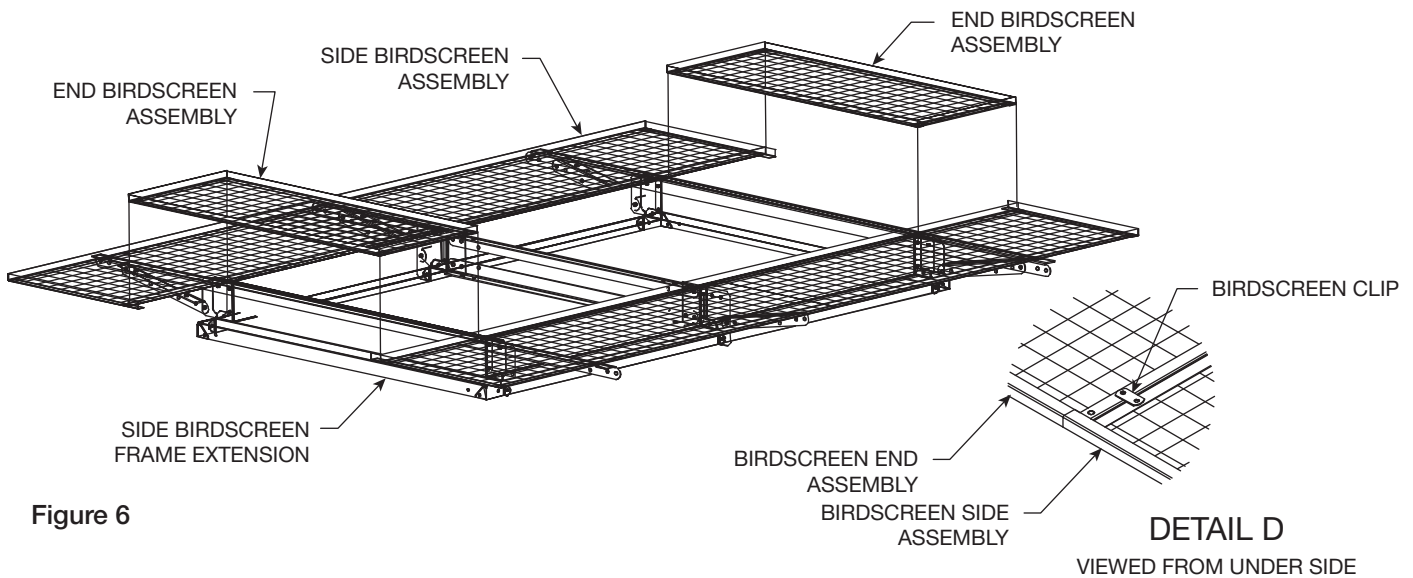

Figure 5

Step 7

Install the end birdscreen assembly, see Figure 6. Turn the birdscreen clips (which are preassembled to the end birdscreen assembly) so that two are under the side birdscreen frame extension and the other two are under the hood support angle and tighten down. See Figure 6, Detail D.



Step 8

Bolt together the hood rail assembly left to the hood rail assembly right, using two 5/16 x 1 inch fasteners per hood rail assembly, see Figure 7.

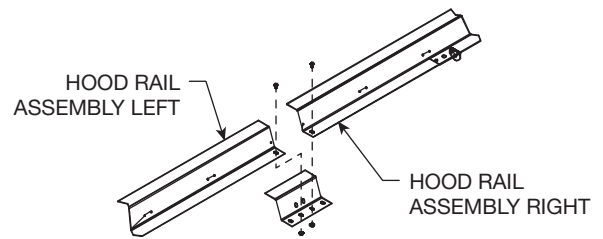

Step 9

Attach the hood rail assembly to the hood support angles using 3/8 x 3/4 inch bolt with 3/8 inch Nyloc nut at each attachment point, see Figure 8.

NOTE: Fasteners should be hand tightened only until Step 11.

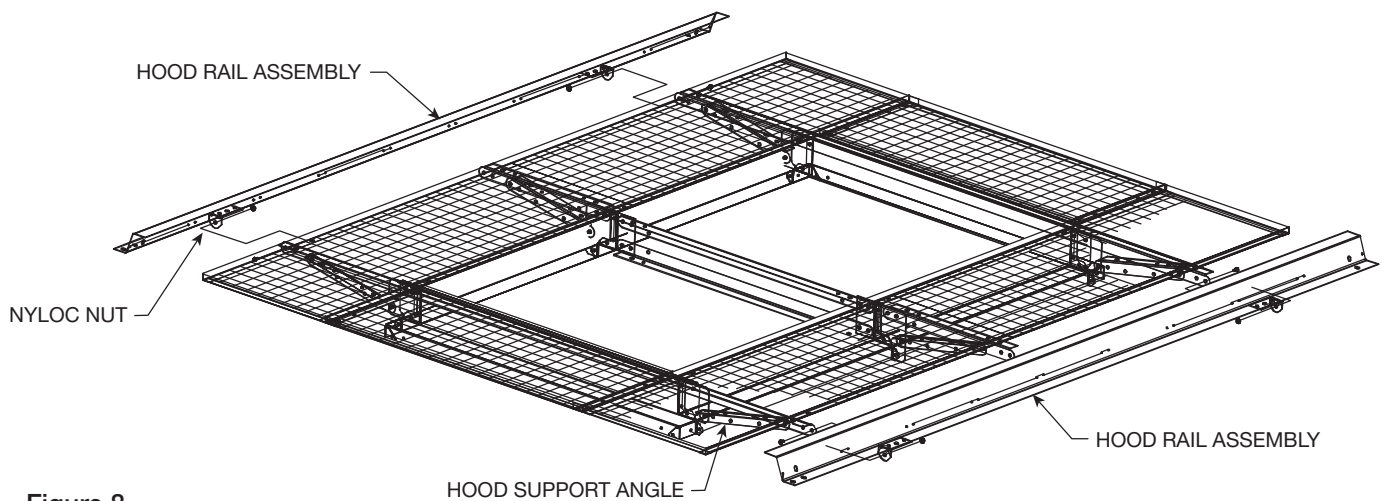

Step 10

Assemble hood panels to hood rail assembly. The hood end assembly with the male rib is to be installed first, see Figure 9, Detail E. Place the remaining hood panels in place, interlocking panels as you go, see Detail E. Secure each hood panel to the hood rail assembly as it is put in place using four 12 x 3/8 inch sheet metal screws with sealing washers per hood panel. The hood end assembly with the female rib is to be installed last.

NOTE: Hoods over 9 feet wide are supplied with special hood clips.

See Detail F. hood panels have predrilled holes for hood clip installation. Install clips as hood panels are being put in place using one 12 x 5/8 inch sheet metal screw with sealing washer per hood clip. to install clips in the last panel, leave the end birdscreen assembly out to provide access to the underside of the hood. The end birdscreen assembly can be easily replaced after the hood is completely assembled.

Step 11

Tighten all pivot bracket fasteners.

NOTE: There may be extra fasteners.

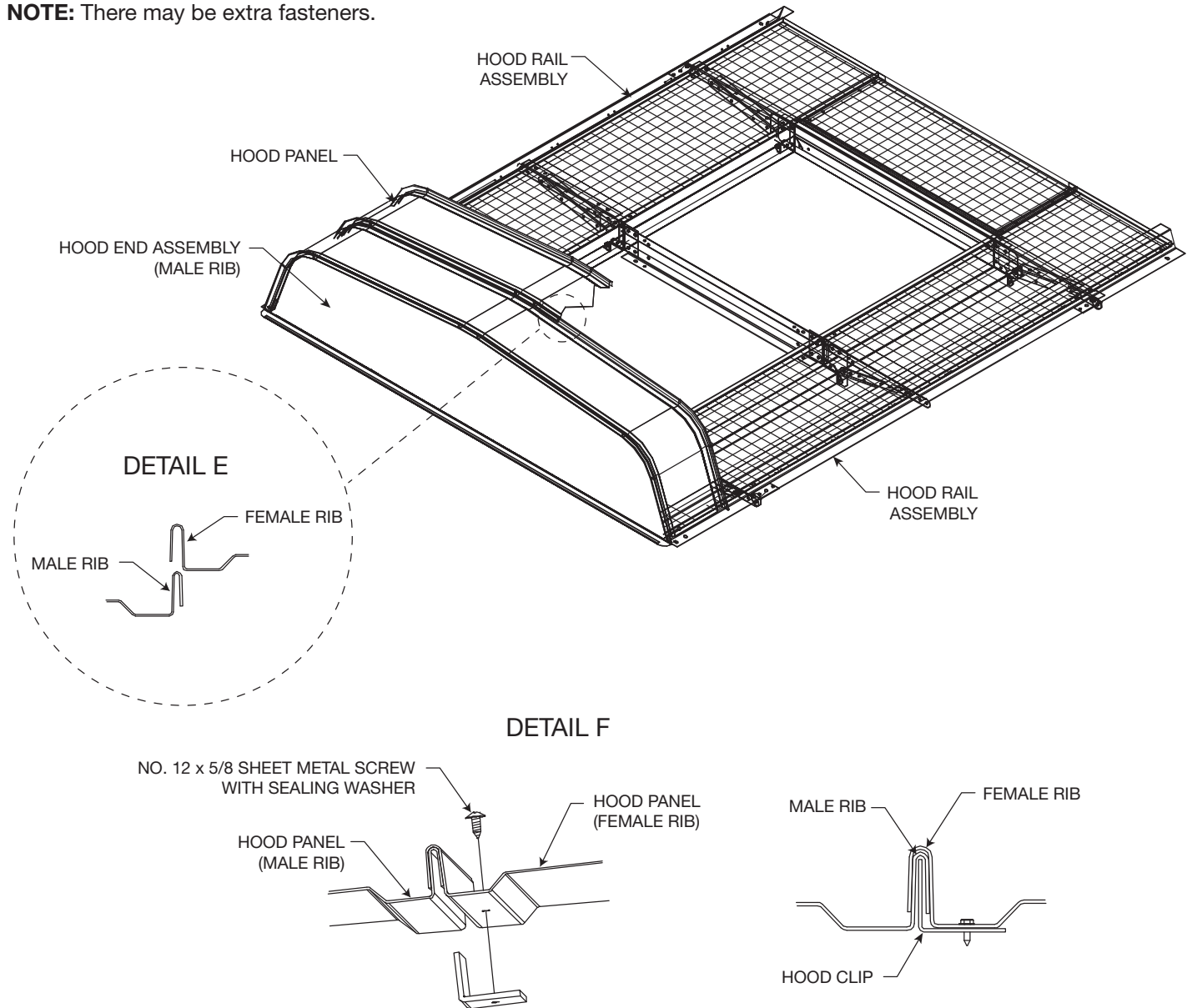
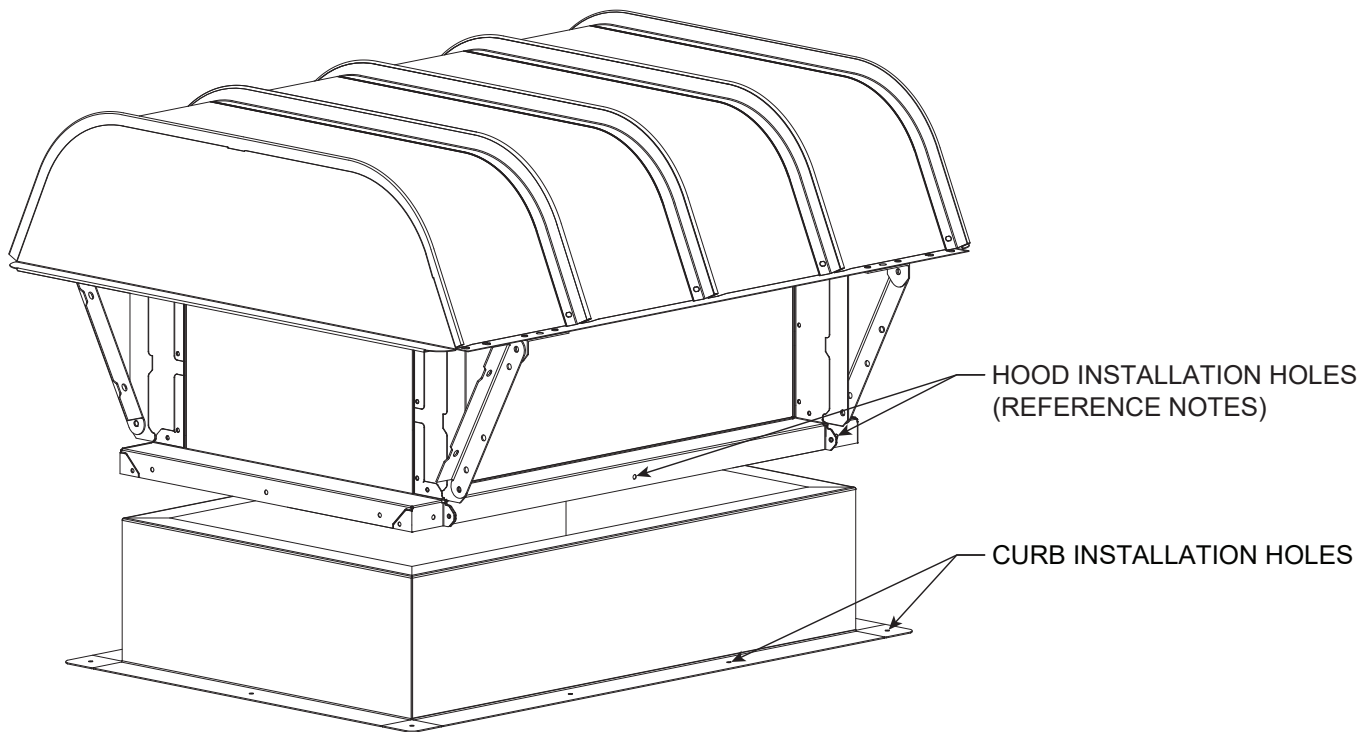

Figure 9

Typical Installation



HOOD INSTALLTION NOTES:

- HOOD INSTALLATION HOLES MAY ONLY BE PRESENT AT BASE CORNERS FROM FACTORY.
- INSTALLATION FASTENERS MAY VARY DUE TO PROJECT LOCATION, LOCAL STRUCTURAL CODES, OR ENVIRONMENTAL CONDITIONS (I.E. HIGH WIND).
- CONSULT PROJECT/SITE ENGINEER ON INSTALLATION HARDWARE INFORMATION INCLUDING QUANTITIES, MAXIMUM SPACING, AND HARDWARE TYPE.

CURB INSTALLATION NOTES:

- CURB ANCHOR HOLES PROVIDED BY MANUFACTURER, HOWEVER ADDITIONAL ANCHORS MAY BE REQUIRED DEPENDING ON SITE LOCATION AND LOCAL CODES.
- CONSULT PROJECT/SITE ENGINEER FOR PROJECT-SPECIFIC ANCHOR CALCULATIONS.

Our Commitment

As a result of our commitment to continuous improvement, Greenheck reserves the right to change specifications without notice.

Product warranties can be found online at Greenheck.com, either on the specific product page or in the literature section of the website at Greenheck.com/Resources/Library/Literature.

Greenheck's Gravity Ventilators catalog provides additional information describing the equipment, fan performance, available accessories, and specification data.

