

Installation, Operation and Maintenance Manual

Please read and save these instructions for future reference. Read carefully before attempting to assemble, install, operate or maintain the product described. Protect yourself and others by observing all safety information. Failure to comply with these instructions will result in voiding of the product warranty and may result in personal injury and/or property damage.

Models SE1, SS1, SE2, SS2, SCR3, SBE-1, SBS-1, SBE-2, SBS-2, SBE-3, SBS-3, SBCE, SBCE, SBCE, SBCE, SBCE

Axial Propeller Wall Fans

Axial propeller wall fans are ideal for factory and warehouse applications where high volumes of air and low pressures are required. From general ventilation to industrial duty, the range of construction and performance capabilities offered represent the most comprehensive sidewall propeller fan line in the industry.

Wall mounted fans include both direct- and belt-driven fans with various impeller styles for exhaust, supply, filtered supply, and reversible applications.

Filtered Supply

Optional filtered supply wall housings are designed with the draw-thru concept to achieve the highest filter and fan efficiencies. Permanent 2-inch (51 mm) washable filters are accessed through a bolted panel and can be easily removed for cleaning.

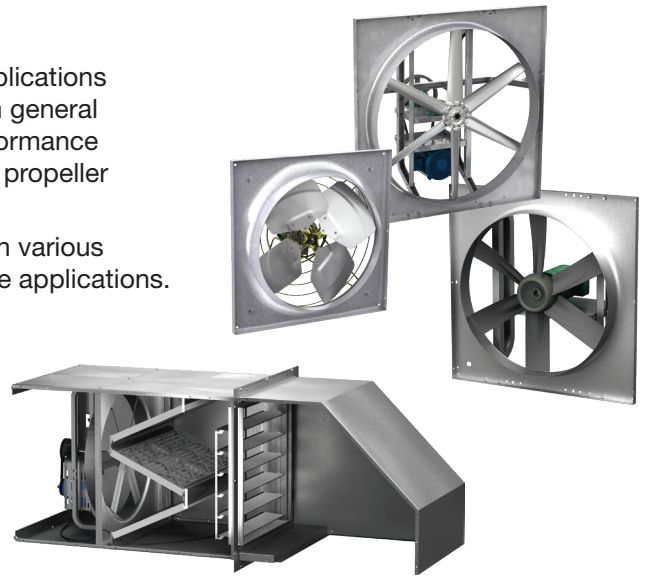

General Safety Information

Only qualified personnel should install this fan. Personnel should have a clear understanding of these instructions and should be aware of general safety precautions. Improper installation can result in electric shock, possible injury due to coming in contact with moving parts, as well as other potential hazards. Other considerations may be required if high winds or seismic activity are present. If more information is needed, contact a licensed professional engineer before moving forward.

1. Follow all local electrical and safety codes, as well as the National Electrical Code (NEC) and the National Fire Protection Agency (NFPA), where applicable. Follow the Canadian Electric Code (CEC) in Canada.
2. The rotation of the propeller is critical. It must be free to rotate without striking or rubbing any stationary objects.
3. Motor must be securely and adequately grounded.
4. Do not spin fan propeller faster than max cataloged fan RPM. Adjustments to fan speed significantly affects motor load. If the fan RPM is changed, the

motor current should be checked to make sure it is not exceeding the motor nameplate amps.

5. Do not allow the power cable to kink or come in contact with oil, grease, hot surfaces or chemicals. Replace cord immediately if damaged.
6. Verify that the power source is compatible with the equipment.
7. Never open access doors to a duct while the fan is running.

DANGER

Always disconnect, lock and tag power source before installing or servicing. Failure to disconnect power source can result in fire, shock or serious injury.

CAUTION

When servicing the fan, motor may be hot enough to cause pain or injury. Allow motor to cool before servicing.

CAUTION

Precaution should be taken in explosive atmospheres.

DANGER
Pour écarter les risques d'incendie, de choc électrique ou de blessure grave, veiller à toujours débrancher, verrouiller et étiqueter la source de courant avant l'installation ou l'entretien.
ATTENTION
Lors de toute intervention sur la soufflante, le moteur peut être suffisamment chaud pour provoquer une douleur voire une blessure. Laisser le moteur refroidir avant toute maintenance.
ATTENTION
Faire preuve de précaution dans les atmosphères explosives.

Receiving

Upon receiving the product, check to ensure all items are accounted for by referencing the delivery receipt or packing list. Inspect each crate or carton for shipping damage before accepting delivery. Alert the carrier of any damage detected. The customer will make notification of damage (or shortage of items) on the delivery receipt and all copies of the bill of lading which is countersigned by the delivering carrier. If damaged, immediately contact your Representative. Any physical damage to the unit after acceptance is not the responsibility of the Manufacturer.

Unpacking

Verify that all required parts and the correct quantity of each item have been received. If any items are missing, report shortages to your local representative to arrange for obtaining missing parts. Sometimes it is not possible that all items for the unit be shipped together due to availability of transportation and truck space. Confirmation of shipment(s) must be limited to only items on the bill of lading.

Note: The filtered supply unit ships with all ordered components completely factory-assembled. The optional weatherhood ships knocked down for field assembly and installation.

Storage

Fans are protected against damage during shipment. If the unit cannot be installed and operated immediately, precautions need to be taken to prevent deterioration of the unit during storage. The user assumes responsibility of the fan and accessories while in storage. The manufacturer will not be responsible for damage during storage. These suggestions are provided solely as a convenience to the user.

Storage Environment

The ideal environment for the storage of fans and accessories is indoors, above grade, in a low humidity atmosphere which is sealed to prevent the entry of blowing dust, rain or snow. Temperatures should be evenly maintained between 30° to 110°F (-1° to 43°C). Wide temperature swings may cause condensation

and “sweating” of metal parts. All accessories must be stored indoors in a clean, dry atmosphere.

Remove any accumulations of dirt, water, ice or snow and wipe dry before moving to indoor storage. To avoid “sweating” of metal parts allow cold parts to reach room temperature. To dry parts and packages use a portable electric heater to get rid of any moisture buildup. Leave coverings loose to permit air circulation and to allow for periodic inspection. The unit should be stored at least 3-1/2 inch off the floor on wooden blocks covered with moisture proof paper or polyethylene sheathing. Aisles between parts and along all walls should be provided to permit air circulation and space for inspection.

Fans designed for outdoor applications may be stored outdoors, if absolutely necessary. Roads or aisles for portable cranes and hauling equipment are needed.

The fan should be placed on a level surface to prevent water from leaking into the fan. The fan should be elevated on an adequate number of wooden blocks so that it is above water and snow levels and has enough blocking to prevent it from settling into soft ground. Locate parts far enough apart to permit air circulation, sunlight and space for periodic inspection. To minimize water accumulation, place all fan parts on blocking supports so that rain water will run off.

Do not cover parts with plastic film or tarps as these cause condensation of moisture from the air passing through heating and cooling cycles. Fan propellers should be blocked to prevent spinning caused by strong winds.

Inspection and Maintenance During Storage

While in storage, inspect fans once per month. Keep a record of inspection and maintenance performed. If moisture or dirt accumulations are found on parts, the source should be located and eliminated. At each inspection, rotate the wheel by hand ten to fifteen revolutions to distribute lubricant on motor. If paint deterioration begins, consideration should be given to touch-up or repainting. Fans with special coatings may require special techniques for touch-up or repair.

Machined parts coated with rust preventive should be restored to good condition promptly if signs of rust occur. Immediately remove the original rust preventive coating with petroleum solvent and clean with lint-free cloths. Polish any remaining rust from surface with crocus cloth or fine emery paper and oil. Do not destroy the continuity of the surfaces. Thoroughly wipe clean with Tectyl® 506 (Ashland Inc.) or the equivalent. For hard to reach internal surfaces or for occasional use, consider using Tectyl® 511M Rust Preventive, WD-40® or the equivalent.

Removing From Storage

As fans are removed from storage to be installed in their final location, they should be protected and maintained in a similar fashion until the fan equipment goes into operation.



Pre-Installation Checks

- Check chart below for correct wall opening dimensions.
- Check motor voltage and amperage rating for compatibility with electrical supply. Supply wiring must be properly fused and conform to local and national codes.
- Motor load amperage must be checked and compared to nameplate rating to avoid serious damage to motor when speed is increased.

Wall Opening Requirements

Wall opening size and propeller-to-damper distance are two important dimensions for fan installation. Fans mounted to the wall require a different wall opening

size than those mounted in collars or wall housings. Propeller-to-damper distance (M) is important to reduce turbulence and damper flutter which may lead to premature damper failure.

Figure 1 and 2 show the wall opening required for installations with either a wall housing or collar.

Figure 3 shows the recommended wall opening and the minimum distance (M) suggested between the fan and damper for direct to wall installations.

Figure 4 shows the dimensions and wall opening required for installations with a filtered supply wall housing.

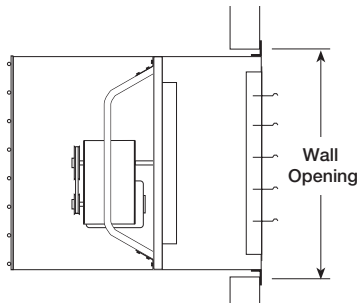

Figure 1 - Wall Housing Installation

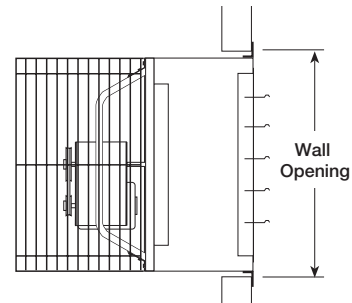

Figure 2 - Wall Collar Installation

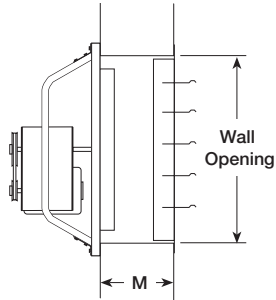

Figure 3 - Direct to Wall Installation

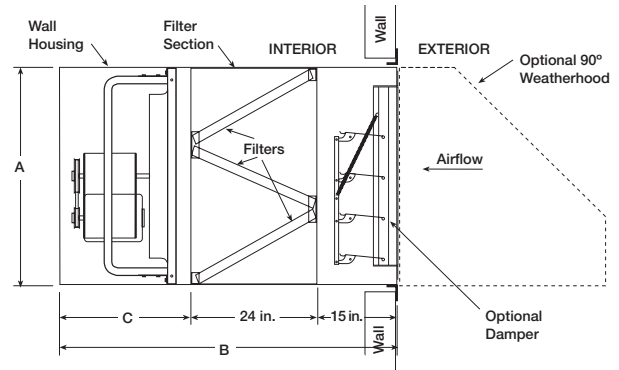

Figure 4 - Filtered Supply Wall Housing Installation

Fan Size	Damper Size Square	Recommended Wall Opening Square			M Minimum	Filtered Supply Wall Housing Only				
		Figures 1 and 2	Figure 3	Figure 4		A	B	C	Filter Quantity & Size	
8	10	14-1/4	10-1/2	-	6	-	-	-	-	-
10	12	16-1/4	12-1/2	-	6	-	-	-	-	-
12	14	19-1/4	14-1/2	-	7	-	-	-	-	-
14	16	21-1/4	16-1/2	-	8	-	-	-	-	-
16	18	23-1/4	18-1/2	-	9	-	-	-	-	-
18	20	25-1/4	20-1/2	-	10	-	-	-	-	-
20	22	27-1/4	22-1/2	-	12	-	-	-	-	-
24	26	33-3/4	26-1/2	33-3/4	13	32-1/4	63	24	4	23-1/4 x 16-1/4
30	32	39-3/4	32-1/2	39-3/4	13	38-1/4	65	26	4	24-5/8 x 19-1/4
36	38	45-3/4	38-1/2	45-3/4	14	44-1/4	67-1/4	28-1/4	6	23-1/4 x 22-1/8
42	44	51-3/4	44-1/2	51-3/4	15	50-1/8	72-7/8	34	6	24-1/8 x 25-1/8
48	50	57-3/4	50-1/2	57-3/4	16	56-1/8	72-7/8	34	12	23-1/4 x 18-3/4
54	56	63-3/4	56-1/2	63-3/4	17	62-3/8	79-11/16	40-11/16	12	23-1/4 x 20-3/4
60	62	69-3/4	62-1/2	-	19	-	-	-	-	-
72	74	84-3/4	74-1/2	-	19	-	-	-	-	-

All dimensions in inches. Filters are 2 inch nominal thickness. Above filter sizes are actual dimensions.

Typical Installation

DANGER

Always disconnect, lock and tag power source before installing or servicing. Failure to disconnect power source can result in fire, shock or serious injury.

DANGER

Pour écarter les risques d'incendie, de choc électrique ou de blessure grave, veiller à toujours débrancher, verrouiller et étiqueter la source de courant avant l'installation ou l'entretien.

Move fan to the desired location and determine the method by which the fan is to be mounted as shown in Figures 1-4 shown on page 3. Optional wall mount housings (Figure 1) and wall mount collars (Figure 2) provide a convenient means of mounting sidewall propeller fans while maintaining the proper distance between propeller and damper.

Attach the fan by inserting a suitable fastener through each of the prepunched mounting holes in the fan panel. Care should be taken not to bend or distort the fan panel or drive components during installation.

Support Braces

Wall Housing sizes 42 and larger with heavy motors and all Filtered Supply Wall Housings need additional bracing.

Filtered Supply Wall Housing Installation

Step 1 Install Housing

Install housing through wall opening from outside.

Temporarily brace end of unit until permanent support braces are installed.

Secure through prepunched holes in angles with suitable fasteners.

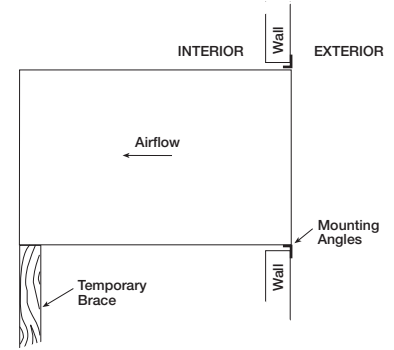

Step 2 Install Support Braces

Choose method of support. Attach support to end of unit (above or below housing) with rods, cable, angle, etc. (supplied by others) as shown.

Vertical braces must carry a minimum load of 500 pounds per support, and angled (45°) braces a minimum of 750 pounds per support based on two supports.

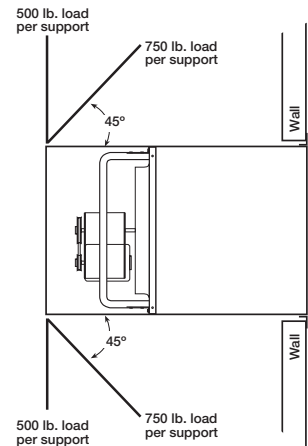

Step 3 Install Weatherhood

Position weatherhood over end of wall housing and fasten through mounting holes with self-tapping screws. Caulk, flash and complete electrical hook-up to finish installation.

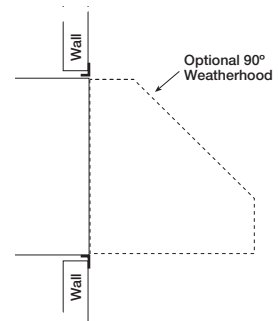

Pre-Start-Up Checks

Check all fasteners and setscrews for tightness. This is especially important for bearing setscrews.

The propeller should rotate freely and not rub on the fan panel venturi. Rotation direction of the propeller should be checked by momentarily turning the unit on. Propeller blade should cup and throw the air when rotating in the correct rotation as shown in the figure. Rotation should be in the same direction as the rotation decal affixed to the unit.

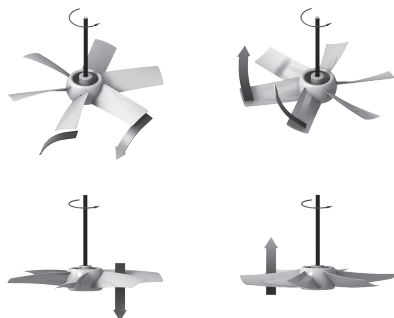

For 3-phase installations, fan rotation can be reversed by simply interchanging any two of the three electrical leads. For single-phase installations follow the wiring diagram located on the motor.

For belt drive fans, the adjustable motor pulley is preset at the factory for the specified fan RPM. Fan speed can be increased by closing or decreased by opening the adjustable pulley. Two or three groove variable pitch pulleys must be adjusted an equal number of turns open. Any increase in fan speed represents a substantial increase in horsepower required from the motor. Always check motor load amperage and compare to nameplate rating when changing fan speed.

Maintenance

DANGER

Always disconnect, lock and tag power source before installing or servicing. Failure to disconnect power source can result in fire, shock or serious injury.

DANGER

Pour écarter les risques d'incendie, de choc électrique ou de blessure grave, veiller à toujours débrancher, verrouiller et étiqueter la source de courant avant l'installation ou l'entretien.

Once the fan has been put into operation, a periodic maintenance program should be set up to preserve the reliability and performance of the fan. Items to be included in this program are belts, bearings, fasteners and setscrews, lubrication, and removal of dust and dirt.

Belts

Premature belt failures are frequently caused by improper belt tension (either too tight or too loose) or misaligned pulleys. The proper tension for operating a V-belt is the lowest tension at which the belts will not slip at peak load conditions. For initial tensioning, the proper belt deflection halfway between pulley centers is 1/64 inch (0.4 mm) for each inch of belt span. For example, if the belt span is 64 inches (1626 mm), the belt deflection should be one inch (25 mm) using moderate thumb pressure at midpoint of the drive. See figure shown below.

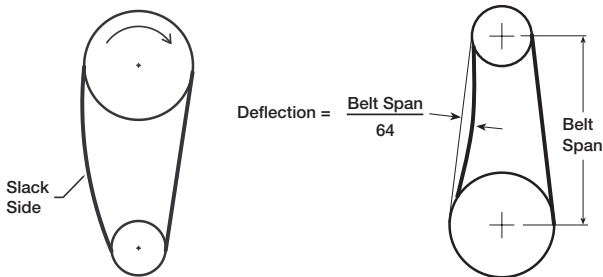

Check belt tension two times during the first 24 hours of operation and periodically thereafter. To adjust belt tension, simply loosen four fasteners (two on each side of the motor plate) and slide the motor plate away from the fan shaft until proper belt tension is attained. On some fans, fasteners attaching the motor to the motor plate must be loosened in order to adjust the belt.

It is very important that the drive pulleys remain in proper alignment after adjustments are made. Misalignment of pulleys will result in premature belt wear, noise, vibration and power loss.

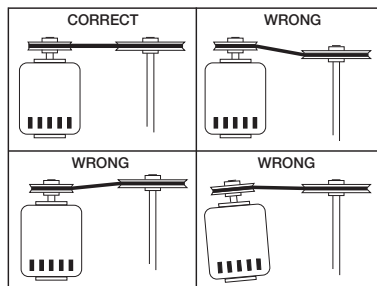

Bearings (for belt drive fans only)

Bearings are the most critical moving part of the fan and should be inspected at periodic intervals. Locking collars and setscrews, in addition to fasteners attaching the bearings to the bearing plate, must be checked for tightness. In a clean environment and temperatures above 32°F (0°C) and below 200°F (93°C), fan shaft bearings with grease fittings should be lubricated semi-annually using a high-quality lithium based grease. If unusual environmental conditions exist, temperatures below 32°F (0°C) and above 200°F (93°C), moisture or contaminants, more frequent lubrication is required.

With the unit running, add grease very slowly with a manual grease gun until a slight bead of grease forms at the seal. Be careful not to unseat the seal by over lubricating or using excessive pressure. Bearings without grease fittings are lubricated for life.

Fasteners and Setscrews

Any fan vibration has a tendency to loosen mechanical fasteners. A periodic inspection should include checking all fasteners and setscrews for tightness. Particular attention should be paid to setscrews or taper-lock bushings attaching the propeller to the motor shaft and the motor shaft to the bearings. Loose bearing setscrews will lead to premature failure of the fan shaft. In addition, check all fasteners attaching the motor to the motor plate.

Lubrication

Refer to the paragraph on bearings for bearing lubrication. Many fractional horsepower motors installed on the smaller fans are lubricated for life and require no further attention. Motors equipped with oil holes should be oiled in accordance with the manufacturer's instructions printed on the motor. Use a high grade SAE 20 machine oil and use caution not to over lubricate. Motors supplied with grease fittings should be greased according to directions printed on the motor.

Removal of Dust and Dirt

Dirt clogs cooling openings on the motor housing, contaminates bearing lubricant and collects on propeller blades causing severe imbalance if left unchecked. The exterior surface of the motor, fan panel and entire propeller should be thoroughly cleaned periodically. Use caution and do not allow water or solvents to enter the motor or bearings. Motors or bearings must not be sprayed with steam or water.

The filters also require periodic cleaning. The 2 inch (51 mm) washable aluminum filters are accessed through the bolted access panel.

Troubleshooting

WARNING

Before taking any corrective action, make certain unit is not capable of operation during repairs.

AVERTISSEMENT

Avant d'entreprendre toute action corrective, s'assurer que l'appareil ne pourra pas fonctionner durant les réparations.

PROBLEM	CAUSE	CORRECTIVE ACTION
Too much airflow	Resistance lower than designed	Decrease fan speed.
Reduced airflow	System resistance too high	Check backdraft dampers for proper operation. Remove obstructions in ductwork. Clean dirty filters. Check for adequate supply air for exhaust fans or exhaust air for supply fans.
	Fan too close to damper	Increase distance between fan and damper.
	Fan speed too low	Increase fan speed.
	Excessive dirt buildup on propeller	Clean propeller.
Excessive noise	Bearings	Tighten collars and fasteners. Lubricate bearings. Replace defective bearings.
	V-belt drive	Tighten pulleys on motor and fan shaft. Adjust belt tension. Align pulleys properly. Replace worn belts or pulleys. See Maintenance.
	Excessive vibration	Clean dirt buildup from propeller. Check all setscrews and fasteners for tightness. Check for worn bearing. Correct propeller imbalance. Check for loose dampers, guards or ductwork.
	Defective motor	Replace motor.
	Variable frequency drive (VFD)	Check VFD for drive setting, some controllers are able to be adjusted to lower the harmonic noises sometimes heard during operation by adjusting a simple setting on the controller.
	Debris	Remove all debris from the fan.
Fan does not operate	Electrical supply	Check fuses/circuit breakers. Check for switches turned off or disconnected. Check for correct supply voltage.
	Drive	Check for broken or worn belts. Tighten loose pulleys.
	Motor	Assure motor is correct horsepower and not tripping overload protector.



Parts List

Each fan bears a manufacturer's nameplate with model number and serial number embossed. This information will assist the local representative and the factory in providing service and replacement parts. Before taking any corrective action, make certain unit is not capable of operation during repairs.

CAUTION

A fan manufactured with an explosion resistant motor does not certify the entire unit to be explosion proof. Refer to UL Listing Mark for the fans approved usage.

CAUTION

La présence d'un moteur antidéflagrant sur un ventilateur ne garantit pas que tout l'appareil est antidéflagrant. Pour connaître les emplois autorisés de l'appareil, voir son marquage de conformité UL.

Direct Drive

SE1 and SS1 (Sizes 8 thru 12 - D, G and E Motor Speeds)

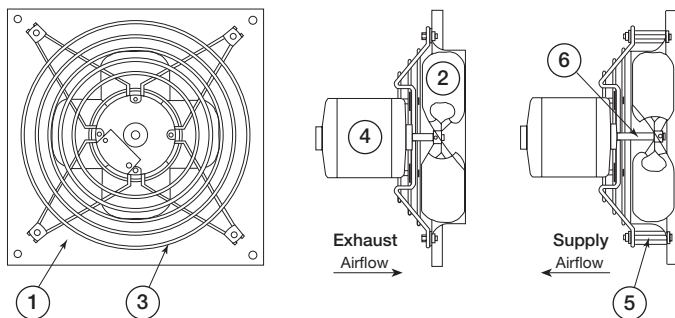

1. Fan Panel
2. Propeller
3. Drive Frame/Motor Support
4. Motor
5. Riser Blocks (4) - supply fan only
6. Shaft Extension - supply fan only

Direct Drive

SE1 and SS1 (Sizes 12 thru 24 - A, B and C Motor Speeds) SE2, SS2 and SCR3

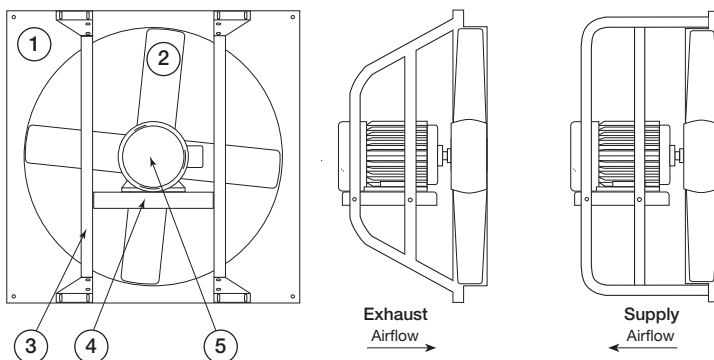

1. Fan Panel
2. Propeller
3. Drive Frame Channels (2)
4. Motor Plate
5. Motor

Belt Drive

SBE-1, SBS-1, SBE-2 and SBS-2 (L and H propellers)

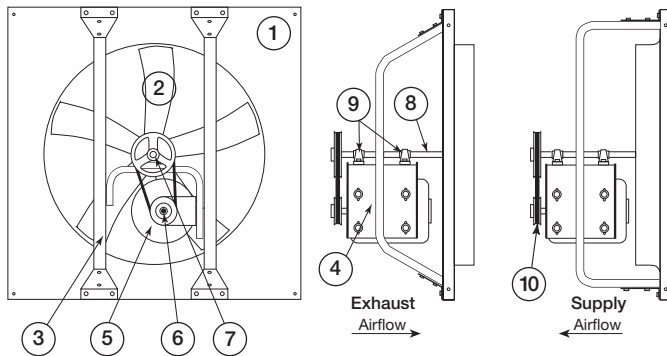

1. Fan Panel
2. Propeller
3. Drive Frame Channel (2)
4. Motor /Bearing Plate
5. Motor
6. Motor Pulley
7. Shaft Pulley
8. Fan Shaft
9. Bearings (2)
10. Belt

Belt Drive

SBE-3, SBS-3, SBCE, SBCE, SBCE and SBCR (L and H propellers)

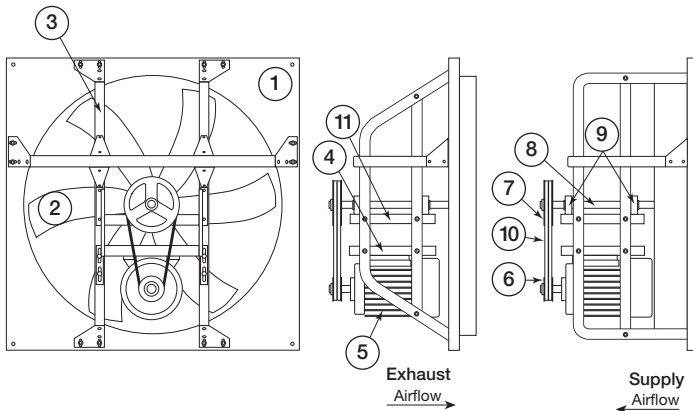

1. Fan Panel
2. Propeller
3. Drive Frame Channel (2)
4. Motor Plate
5. Motor
6. Motor Pulley
7. Shaft Pulley
8. Fan Shaft
9. Bearings (2)
10. Belt
11. Bearing Plate

Our Commitment

As a result of our commitment to continuous improvement, Greenheck reserves the right to change specifications without notice.

Product warranties can be found online at Greenheck.com, either on the specific product page or in the literature section of the website at Greenheck.com/Resources/Library/Literature.

Greenheck's Sidewall Propeller Fans catalog provides additional information describing the equipment, fan performance, available accessories, and specification data.

AMCA Publication 410-96, Safety Practices for Users and Installers of Industrial and Commercial Fans, provides additional safety information. This publication can be obtained from AMCA International, Inc. at www.amca.org.

