

**Refer to:**

'Installation Instructions for SMD, SESMD, SSSMD series models' (Part #461338) for additional details.



See complete marking on product.

UL 555S Classification  
R13317

**1. Smoke Damper Requirements and Application**

Smoke dampers are required to close and prevent the passage of air and smoke through the ducts or ventilation openings in smoke barriers. Smoke dampers are also applied in engineered smoke control systems to establish air pressure differentials and thereby prevent the spread of smoke. These dampers are designed to operate with blades running horizontally. Dampers can be vertically or horizontally installed at, in accordance with NFPA 90A or adjacent to the point where the duct passes through the smoke barrier.

**2. Location of Damper in Ductwork**

Place the damper assembly in its proper position relative to the barrier. The plane of the closed damper blades must be within 24 in. (610 mm) of the rated smoke barrier and before any duct inlets or outlets.

**3. Attaching Damper to the Duct**

The damper is flange mounted to the duct, sleeve, or wall opening using:

- #10 sheet metal screws,
- ¼ in. (6 mm) diameter nuts and bolts,
- tack or spot welds. or
- ⅜ in. (5 mm) diameter steel pop rivets.

Attachments must be made at each flange spaced a maximum of 6 in. (152 mm) on centers and a maximum of 2 in. (51 mm) from corners.

**4. Sealing the Installation**

The following duct sealants may be used to seal between the damper's flange and the mating surface in accordance with SMACNA recommendations:

- Precision PA2084T duct sealant adhesive, Design Polymetrics DP1010 water base duct sealant, Grey Pookie, or Ductmate PROseal®

**5. Actuator Connections**

Electrical and/or pneumatic connections to damper actuators should be made in accordance with wiring and piping diagrams developed in compliance with applicable codes, ordinances and regulations.

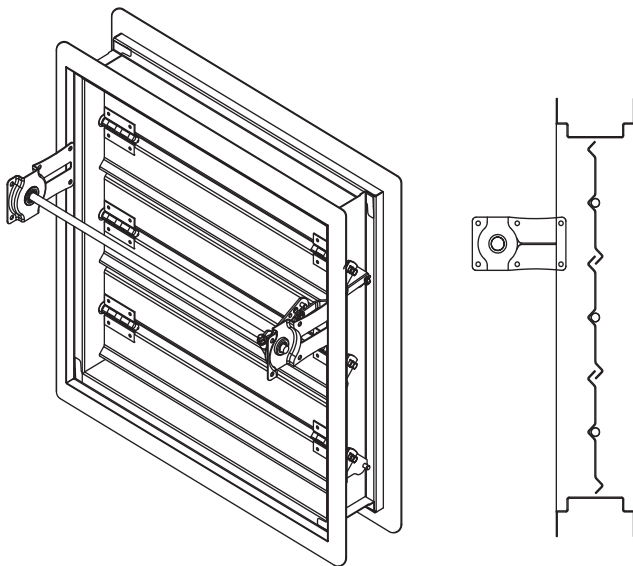

Damper Model	Maximum Single Section Size in. (mm)	Maximum Overall Size for Multiple Section Dampers in. (mm)
SMD-301, 302 SMD-301M	32 x 50 (813 x 1270)	128 x 100 or 256 x 50 (3251 x 2540) or (6502 x 1270)
SMD-401	48 x 60 (1219 x 7315)	192 x 72, 48 x 288, or 384 x 36 (4877 x 1829, 1219 x 7315, or 9754 x 914)
SMD-401M	48 x 36 (1219 x 914)	144 x 36 (3658 x 914)

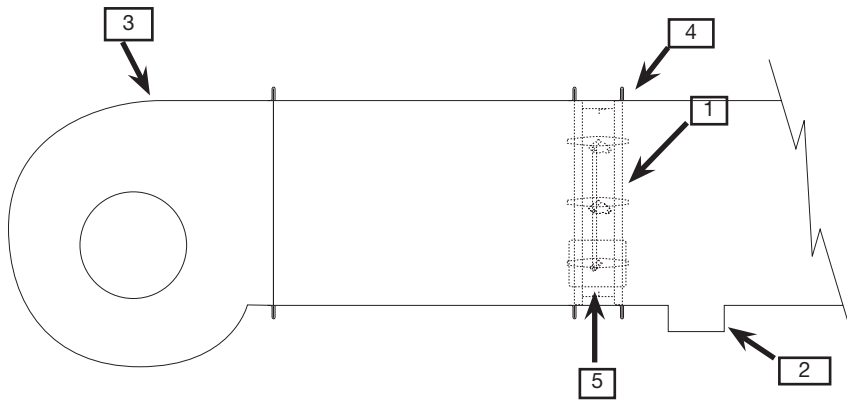

Item	Description
1	Damper frame
2	Duct outlet
3	Fan (not limited to centrifugal)
4	#10 sheet metal screws
5	Actuator
The actuators are to be installed to function per system requirements and to be controlled by smoke detection devices.	

### Fan Isolation Application

For air handling equipment isolation, leakage rated dampers are designed to operate with blades running horizontally. Dampers can be installed in a vertical or horizontal position. Sealants and damper seal materials meet the requirements for NFPA 90A for smoke developed rating ( $\leq 50$ ) and flame spread index ( $\leq 25$ ) as tested per UL 723/ASTME84-91 A/NFPA 255. Dampers can be attached to the fan system discharge or inlet without being 24 in. (610mm) of a smoke barrier when used as an air handling equipment isolation damper.

### Our Commitment

*As a result of our commitment to continuous improvement, Greenheck reserves the right to change specifications without notice.*

Product warranties can be found online at [Greenheck.com](http://Greenheck.com), either on the specific product page or in the literature section of the website at [Greenheck.com/Resources/Library/Literature](http://Greenheck.com/Resources/Library/Literature).

