

## Installation, Operation and Maintenance Manual

Please read and save these instructions for future reference. Read carefully before attempting to assemble, install, operate or maintain the product described. Protect yourself and others by observing all safety information. Failure to comply with these instructions will result in voiding of the product warranty and may result in personal injury and/or property damage.



### Table of Contents

Electrical Guidelines . . . . .	1
General Information . . . . .	2
Damper Supported by a Ceiling Grid System . . . . .	2-3
• Lay-in Diffuser . . . . .	2
• Lay-in diffuser with Steel Drop . . . . .	3
Damper Supported From Ductwork Above . . . . .	4-5
• Surface Mounted Air Devices . . . . .	4
• Recess Mounted Air Devices. . . . .	5
Damper Supported Directly From Structure. . . . .	5-8
• Ducted Surface Mounted Air Devices . . . . .	5
• Ducted Recess Mounted Air Devices . . . . .	6
• Unducted Surface Mounted Air Devices . . . . .	7
• Unducted Recess Mounted Air Devices . . . . .	7
Connection and Operation of Thermostat . . . . .	8

### Receiving and Handling

Upon receiving dampers, check for both obvious and hidden damage. If damage is found, record all necessary information on the bill of lading and file a claim with the final carrier. Check to be sure that all parts of the shipment, including accessories, are accounted for.

Dampers must be kept dry and clean. Indoor storage and protection from dirt, dust and the weather is highly recommended. Do not store at temperatures in excess of 100°F (38°C).

### Safety Warning

Improper installation, adjustment, alteration, service or maintenance can cause property damage, injury or death. Read the installation, operating, and maintenance instructions thoroughly before installing or servicing this equipment.

**“UL CLASSIFIED (see complete marking on product)”**

**“UL CLASSIFIED to Canadian safety standards (see complete marking on product)”**

Standard 555C (Listing #R13446)

Standard 555S (Listing # R13317)

### Electrical Guidelines

#### Electrical Guidelines

All wiring shall be done in accordance with the National Electrical Code ANSI/NFPA-70 latest edition, any local codes that may apply, and wiring diagrams developed in compliance with the job or project design and specifications.

#### Important!

Electrical input may be needed for this equipment. This work should be performed by a qualified electrician. Verify power before wiring actuator. Greenheck is not responsible for any damage to, or failure of the unit caused by incorrect field wiring. To avoid causing death or serious bodily harm to building occupants, follow all instructions carefully. Dampers must close completely to preserve the integrity of the fire smoke separation.

## General Information

---

- 1) **Application:** Model CRD-501 is a UL labeled ceiling radiation damper. When installed as shown, they provide appropriate protection for air inlet or outlet penetrations in the ceiling membrane of floor/ceiling and roof/ceiling assemblies with fire resistance ratings of up to 3 hours. Use of these UL and Warnock Hersey labeled ceiling damper eliminates the need to use “hinged door” type dampers or other alternate protection methods for specific floor/ceiling and roof/ceiling designs shown in the UL FIRE RESISTANCE DIRECTORY (FRD).
- 2) **System Components:** All system components (ducts, duct drops, hanger wires, sleeves, and diffuser pan) must be constructed of steel. The diffuser core may be non-ferrous. Grilles may be non-metallic. Flexible duct (if used) must be Class 1 or Class 0 type, bearing the UL listing mark. Maximum length of flex duct shall not exceed 14 feet (4.27m). The installations and air devices shown in these instructions must also incorporate any specific requirements in the FRD. Note that both “Design Information - General” and individual ceiling/floor or ceiling/roof design listings apply.
3. **Ceiling Penetrations:** Ceiling penetration should be located within ceiling tiles or panels without necessitating cuts in the ceiling suspension main runners or cross tees. If required, a maximum of one runner or cross tee may be cut to enable proper damper location and installation. Each cut end shall be supported by a minimum 12 SWG vertical hanger wire. A ½ in. (13 mm) clearance must be maintained between the air inlet/outlet and the cut end of the runner or cross tee.
4. **Connections:** Connections must be made using #8 sheet metal screws, ⅜ in. (4.7 mm) tubular steel rivets, tack, or spot welds. Use a minimum three equally spaced connections. Space fasteners a maximum of 6 in. (152 mm) apart. All screws or rivet attachments shall be placed a minimum of ⅜ in. (4.7 mm) from the edge of the damper frame, duct drop, diffuser, or grille frame. When making connections, the ceiling radiation damper may slide over the neck or inside the neck of the diffuser, grille, or inlet/outlet device. **Important:** Connections to the damper frame must not interfere with the damper blade operation.
5. **Thermal Blanket:** In those installation where the opening in the ceiling membrane is larger than the ceiling damper (more than 1 in. (25 mm) in any dimension), a Thermal Insulating Blanket (Model TB or QB) must be installed by laying over the exposed surface of the air inlet or outlet device. The Thermal Blanket rests upon and protects exposed portions of the air device and may fit inside adjacent Tee Bars (if any),
6. **Thermostat:** The CRD-501 is shipped from the factory with the blades closed. The CRD-501 is equipped with RRL2 (Resettable Link).

## Dampers Supported by a Ceiling Grid System

---

Exposed Tee Bar ceiling grid systems often use “Lay In” style air inlets and outlets. With attention to the following requirements, the ceiling grid system provides all required support for installation of “Lay In” style ceiling dampers and air inlets and/or outlets.

Ceiling openings up to a 24 in. x 24 in. (576 in.<sup>2</sup>) [610 mm x 610 mm (.371 m<sup>2</sup>)] maximum are allowable. Maximum size limits of each individual ceiling damper model must be observed.

The four corners of the grid module containing the air device (or the midpoint of the adjacent cross-tees) shall be directly supported from the structural members of the floor or roof by 12 SWG minimum vertical hanger wires. When the duct extends over the intersections of the grid members, 16 ga. x 1 1/2 in. (1.5 mm x 38 mm) steel channels with ⅜ in. (14 mm) minimum flanges shall be used to ensure that the grid is supported from structural members by 12 SWG minimum hanger wires. All UL Classified ceiling assemblies require lay-in ceiling panels be cut to fill the remainder of hole openings larger than 24 in. x 24 in. (610 mm x 610 mm) and shall provide a minimum of ⅜ in. (9.5 mm) bearing on the ceiling grid members.

### Lay-In Diffuser Applications

#### Lay-in Diffuser

- Lay-in diffuser install directly into exposed Tee bar grid system.
- Ceiling damper attaches to diffuser neck (see General Information, Connections).
- Thermal blanket required (see General Information, Thermal Blanket)
- If flexible duct is used (see General Information, System Components), it shall be fastened to the diffuser neck with a steel clamp or #16 SWG minimum wire.

**Note:**

- 1) The flexible air duct shall not rest on the back surface of the ceiling grid or panels (provide a minimum of 4 in. [102 mm] clearance).
- 2) The flexible air duct shall not interfere with the closing of the ceiling damper.

Model CRD-501 may be installed as shown in **Figure 1**.

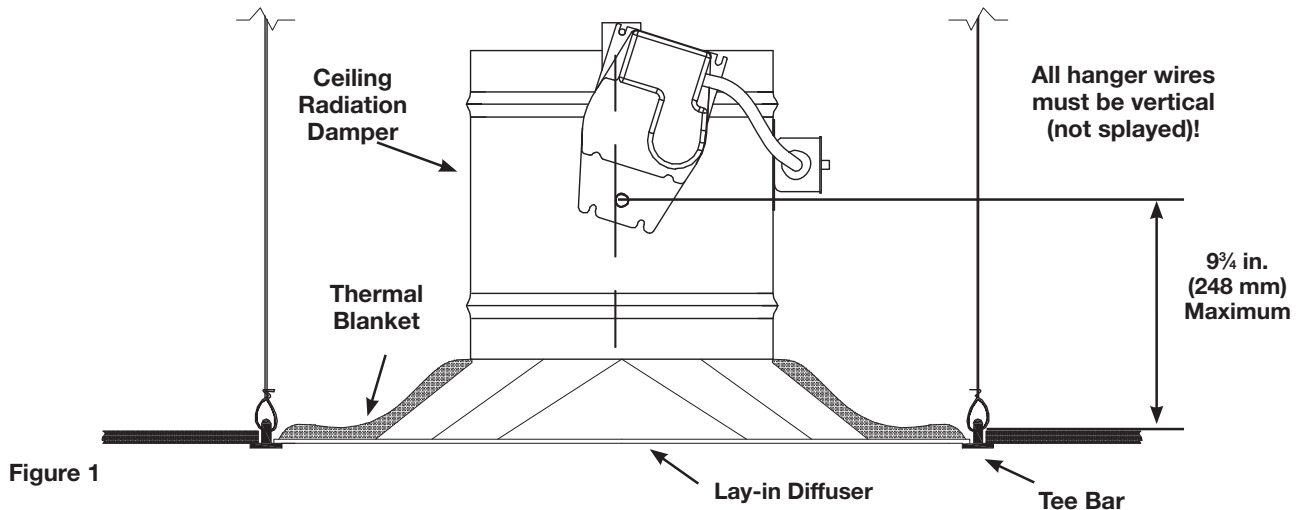

Figure 1

**Lay-In Diffuser with Steel Duct Drop**

- Lay-in diffuser with steel duct drop installs directly into exposed Tee bar grid system.
- Thermal blanket required (See General Information, Thermal Blanket)
- Connection of ceiling radiation damper, diffuser neck, and steel duct drop (See General Information, Connections) may be satisfied as follows:

Ceiling radiation damper may be connected directly to the diffuser neck and then the duct drop connected to the damper (see **Figure 2, Detail B**).

Model CRD-501 may be installed as shown in **Figure 2**.

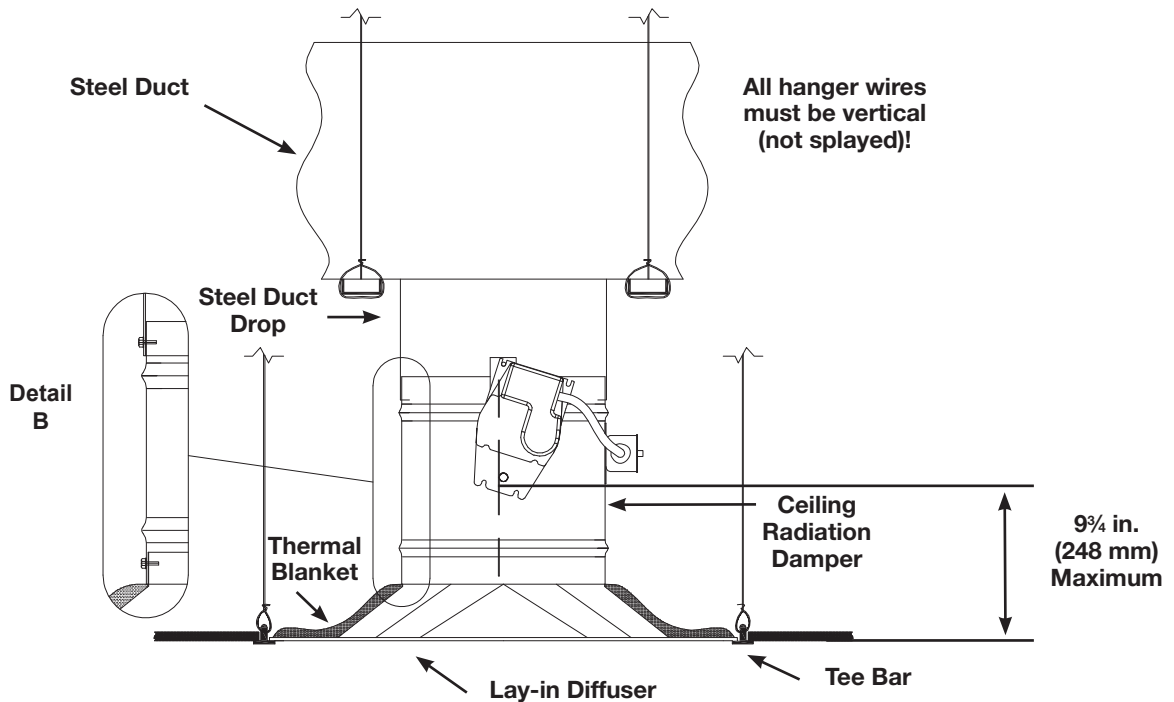

Figure 2

# Dampers Supported From Ductwork Above

## A Note About Support

When main ducts are supported by 16 ga. x 1 ½ in. (1.5 mm x 38 mm) steel channels (with ¼ in. [14 mm] minimum flanges) located 1 in. to 3 in. (25 mm to 76 mm) from and on both sides of a steel duct drop and these channels are suspended by #12 SWG wire from structure above, the steel duct drop provides all required support for ceiling damper and air inlet or outlet devices. Air device flange must overlap the ceiling membrane by a minimum of 1 inch (25 mm).

Follow guidelines in General Information, Ceiling Penetrations and Connections when preparing opening in the ceiling membrane and making connections.

## Surface Mounted Air Inlet or Outlet Devices

- Maximum size of permitted opening equals maximum size of available listed ceiling radiation dampers.
- Opening in ceiling membrane (See General Information, Ceiling Penetrations) may be up to one inch larger than the size of the ceiling radiation damper (i.e. a 12 inch diameter [305 mm] ceiling radiation damper could have a maximum ceiling membrane opening of 13 in. diameter [330 mm]).
- Connection of ceiling radiation damper, air device neck, and steel duct drop (see General Information, Connections) may be satisfied as follows:

Ceiling radiation damper may be connected to the air device neck and then the duct drop connected to the damper (see **Figure 3, Detail B**).

## Non-Ferrous Air Devices

Air devices that have non-ferrous frames.

Ceiling membrane openings that utilize non-ferrous devices require one of the following:

- 1) A steel duct drop from the damper extension should extend to the bottom surface of the ceiling membrane and the opening in the ceiling membrane (see General Information, Ceiling Penetrations) should equal to the outside of the duct drop (see **Figure 3, Detail C**).
2. A steel angle should be attached to the bottom of the ceiling radiation damper and span the gap from the ceiling radiation damper to the bottom of the ceiling membrane. The steel angle should overlap the ceiling membrane (See **Figure 3, Detail D**).

Model CRD-501 may be installed as shown in **Figure 3**.

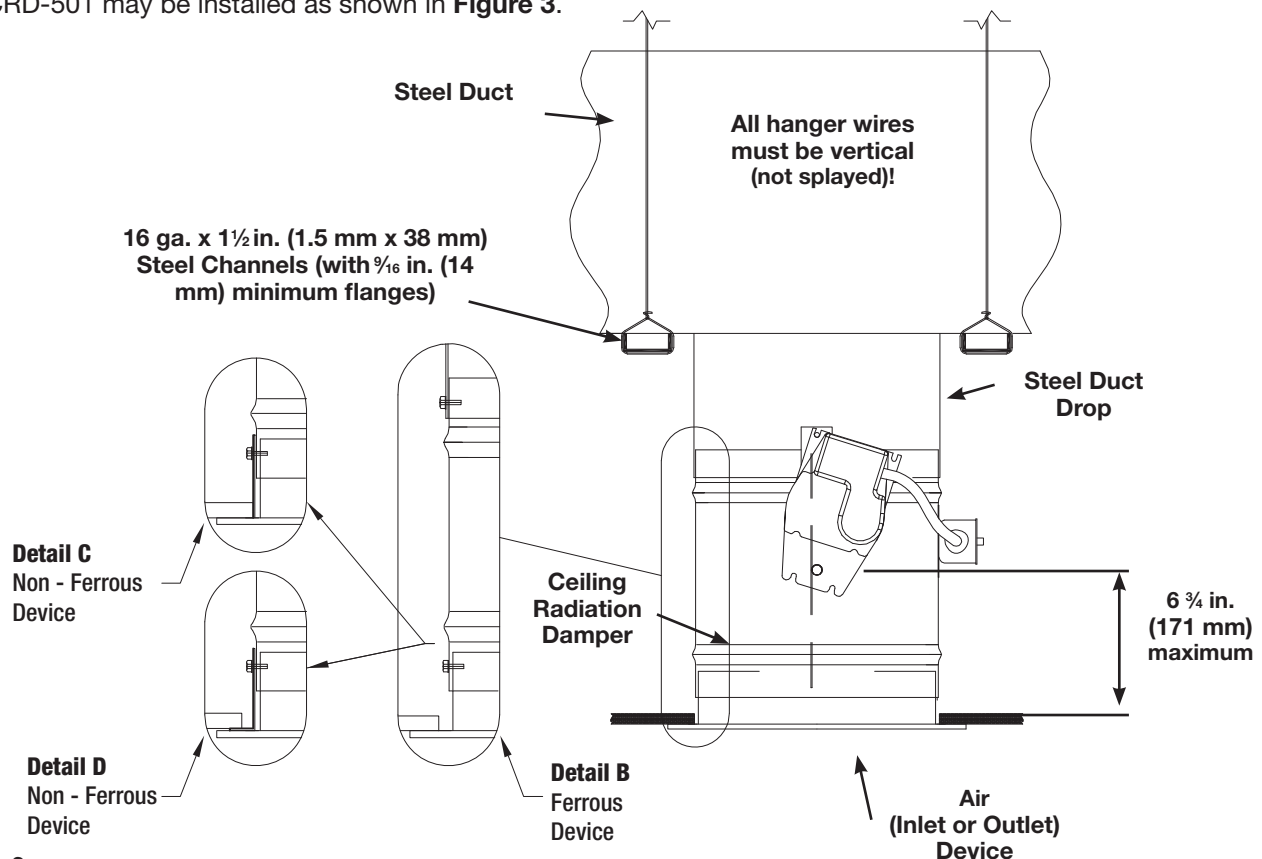

Figure 3

## Recess Mounted Air Inlet or Outlet Devices

- Opening in ceiling membrane (see General Information, Ceiling Penetrations) is more than one inch larger than nominal size of ceiling damper (i.e. a 12 inch diameter [305 mm] ceiling radiation damper could have a maximum ceiling membrane opening of 13 in. diameter [330 mm]).
- Thermal blanket is required (see General Information, Thermal Blanket)
- Connection of ceiling radiation damper, air device neck, and steel duct drop (see General Information, Connections) may be satisfied as follows:

Ceiling radiation damper may be connected directly to the air device neck and then the duct drop connected to the damper (see **Figure 4, Detail B**).

Model CRD-501 may be installed as shown in **Figure 4**.

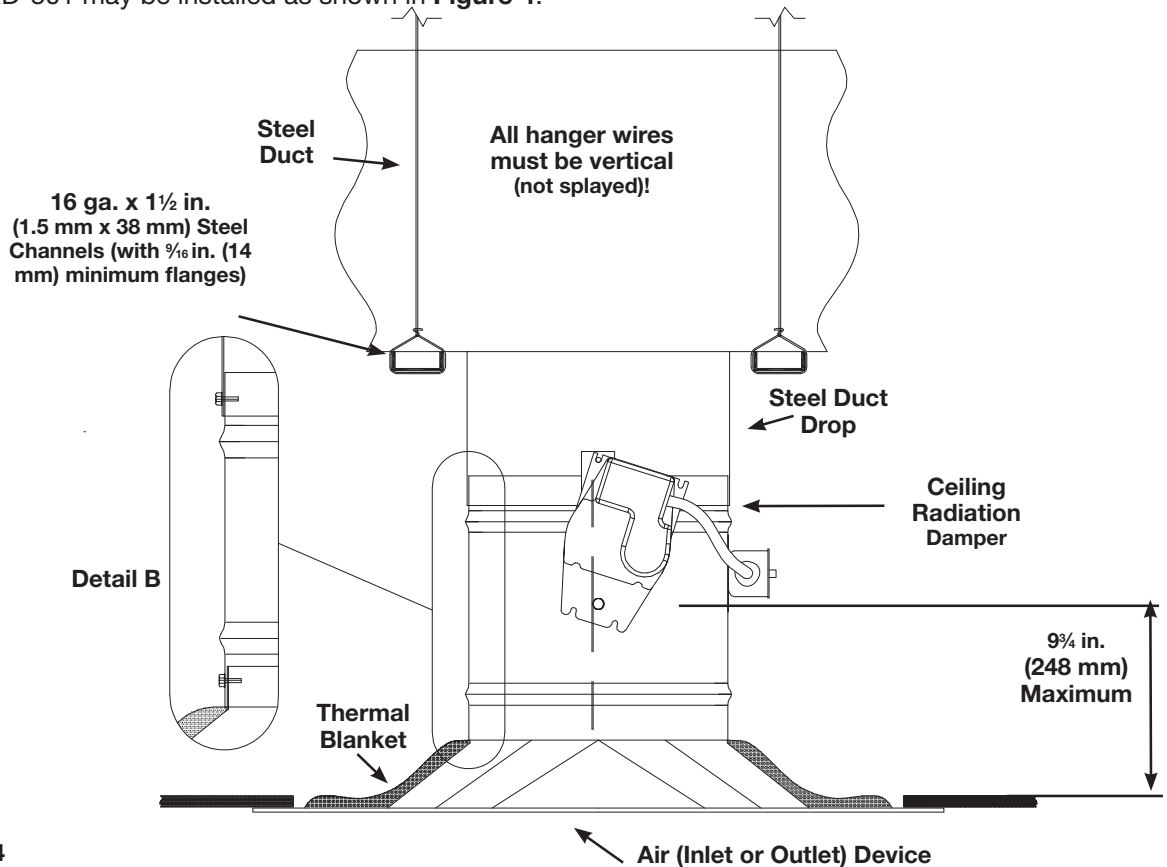

Figure 4

## Dampers Supported Directly from Structure

### A Note About Support

Ceiling radiation dampers and air inlet or outlet devices may also be supported directly from the structure above using one or more of the methods described in **Figures 5, 6, 7, or 8**. When channels are to be used as support, they must be 16 ga. x 1 1/2 in. (1.5 mm x 38 mm) steel channels with 1/16 in. (14 mm) minimum flanges (2 required per damper on opposite sides). Air device flange must overlap the ceiling membrane by a minimum of one inch (25 mm). Follow guidelines in General Information, Ceiling Penetrations and Connections when preparing opening in the ceiling membrane and making connections.

### Ducted Surface Mounted Air Inlet or Outlet Devices

- Maximum size of permitted opening equals the maximum size of available listed ceiling radiation dampers.
- Opening in ceiling membrane (see General Information, Ceiling Penetrations) may be up to one inch larger than the nominal size of the ceiling radiation damper (i.e. a 12 inch diameter [305 mm] ceiling radiation damper could have a maximum ceiling membrane opening of 13 in. diameter [330 mm]).
- Steel channel is connected directly to ceiling radiation damper (see General Information, Connections).
- Connection of ceiling radiation damper, air device neck, and steel duct drop (see General Information, Connections) may be satisfied as follows:

Ceiling radiation damper may be connected directly to the air device neck and then the duct drop connected to the damper (see **Figure 5, Detail B**).

## Non-Ferrous Air Devices

Air devices that have non-ferrous frames.

Ceiling membrane openings that utilize non-ferrous devices require one of the following:

- 1) A steel duct drop extension should extend from the damper to the bottom surface of the ceiling membrane and the opening in the ceiling membrane (see General Information, Ceiling Penetration) should be equal to the outside of the duct drop (see **Figure 5, Detail C**). Models CRD-501 may be installed as shown in **Figure 5**.
2. A steel angle should be attached to the bottom of the ceiling radiation damper and span the gap from the ceiling radiation damper to the bottom of the ceiling membrane. The steel angle should overlap the ceiling membrane (see **Figure 5, Detail D**).

Model CRD-501 may be installed as shown in **Figure 5**.

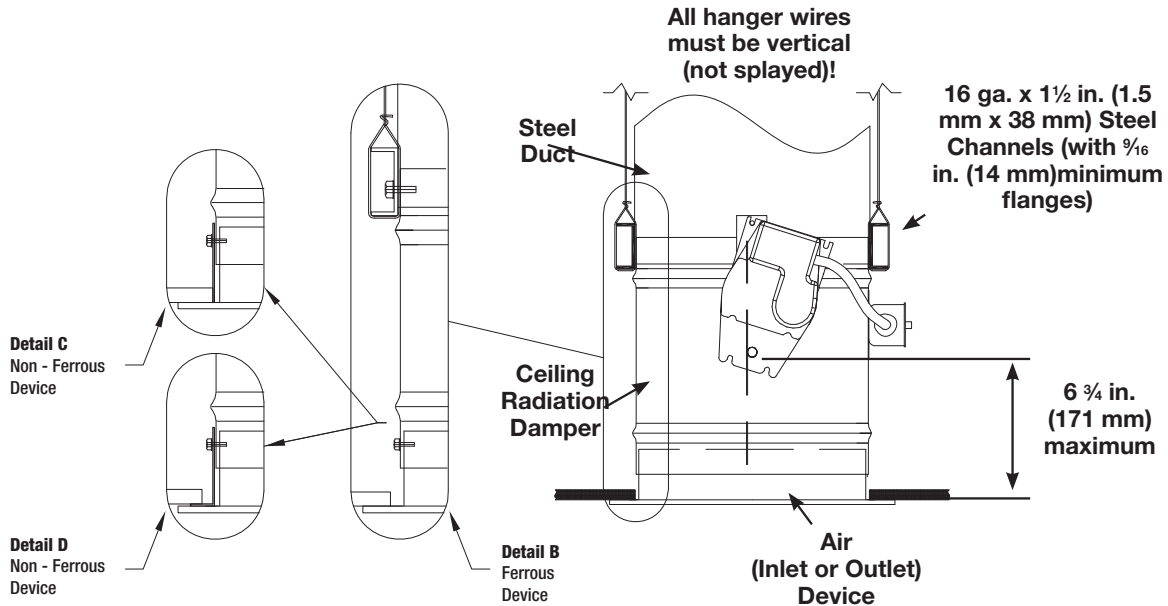

Figure 5

## Ducted Recess Mounted Air Inlet or Outlet Devices

- Opening in ceiling membrane is more than one inch (25 mm) larger than nominal size of ceiling damper (i.e. a 12 inch diameter [305 mm] ceiling radiation damper could have a maximum ceiling membrane opening of 13 inch diameter [330 mm]).
- Maximum size of opening is 24 in. (610 mm) diameter (576 sq. in.)
- Thermal blanket is required (see General Information, Thermal Blanket)
- Connection of ceiling radiation damper, air device neck, and steel duct crop (see General Information, Connections) may be satisfied as follows:

Ceiling radiation damper may be connected directly to the air device neck and then the duct drop connected to the damper (see **Figure 6, Detail B**).

Models CRD-501 may be installed as shown in **Figure 6**.

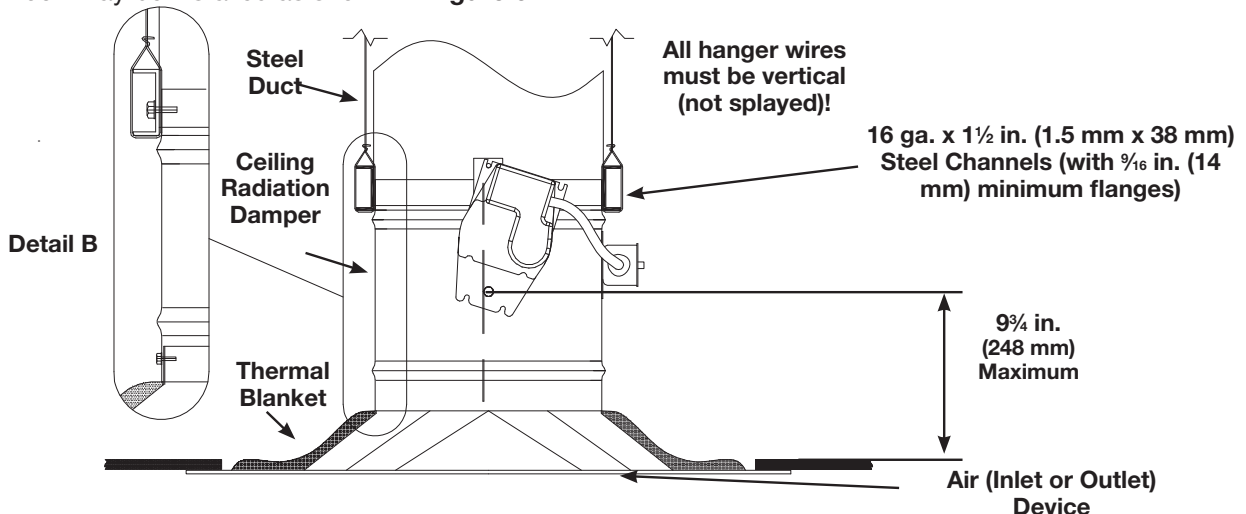

Figure 6

## Unducted Surface Mounted Air Inlet or Outlet Devices

- Maximum size of permitted opening equals maximum size of available listed ceiling radiation dampers.
- Opening in ceiling membrane may be up to one inch larger than the nominal size of the ceiling radiation damper (i.e. a 12 inch diameter [305 mm] ceiling radiation damper could have a maximum ceiling membrane opening of 13 in. diameter [330 mm]).
- Connection of ceiling radiation damper and air device neck (see General Information, Connections) may be satisfied in three ways:
  1. Ceiling radiation damper may be connected directly to the air device neck and supported by steel channel (see **Figure 7, Detail A**)
  2. Ceiling radiation damper may be connected directly to the air device neck and supported by hanger straps (see **Figure 7, Detail B**).
  3. Ceiling radiation damper may be connected directly to the air device neck and supported by direct suspension with wires looped through holes in the damper frame before tying (see **Figure 7, Detail C**).

### Non-Ferrous Air Devices

Air devices that have non-ferrous frames.

Ceiling membrane openings that utilize non-ferrous devices require one of the following:

1. A steel extension should extend from the ceiling radiation damper to the bottom surface of the ceiling membrane (see General Information, Ceiling Penetrations) should be equal to the outside of the steel extension (see **Figure 7, Detail D**).
2. A steel angle should be attached to the bottom of the ceiling radiation damper and span the gap from the ceiling radiation damper to the bottom of the ceiling membrane. the steel angle should overlap the ceiling membrane (see **Figure 7, Detail E**).

Model CRD-501 may be installed as shown in **Figure 7**.

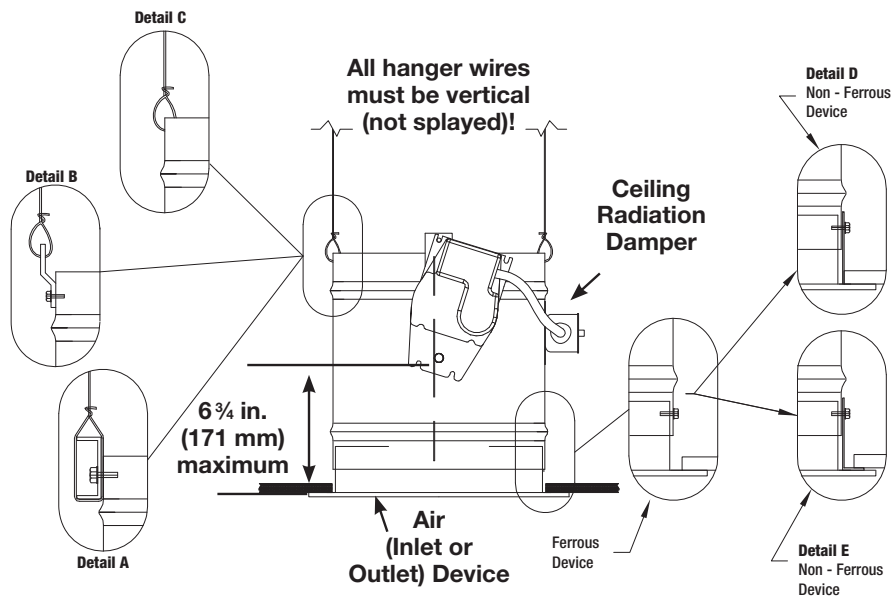

Figure 7

## Unducted Recess Mounted Air Inlet or Outlet Devices

- Opening in ceiling membrane is more than one inch (25 mm) larger than nominal size of ceiling damper (i.e. a 12 inch diameter [305 mm] ceiling radiation damper could have a maximum ceiling membrane opening of 13 in. diameter [330 mm]).
- Maximum size of opening is 24 in. (576 sq. in.) [610 mm (.371 sq. m)].
- Thermal blanket is required. (see General Information, Thermal Blanket).
- Connection of ceiling radiation damper and air device neck may be satisfied in three ways:
  1. Ceiling radiation damper may be connected directly to the air device neck and supported by steel channel (see **Figure 8, Detail A**).
  2. Ceiling radiation damper may be connected directly to the air device neck and supported by hanger straps (see **Figure 8, Detail B**).

3. Ceiling radiation damper may be connected directly to the air device neck and supported by direct suspension with wires looped through holes in the damper frame before typing (see **Figure 8, Detail C**).

Models CRD-501 may be installed as shown in **Figure 8**.

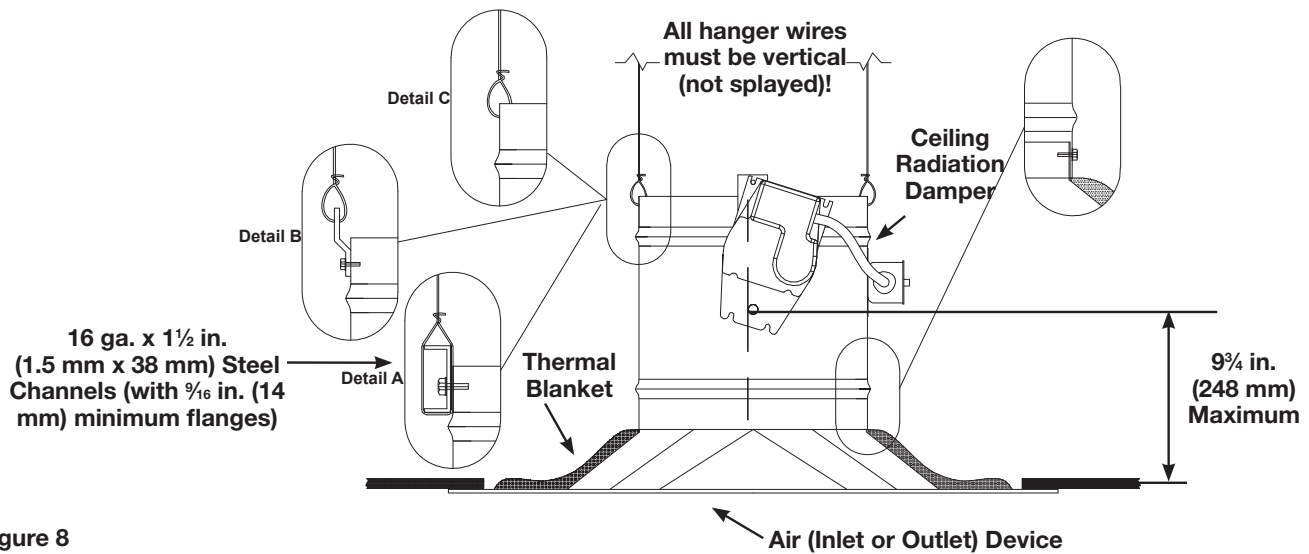

Figure 8

## Connection and Operation of Thermostat (RRL2)

**RRL2** - Dampers will be supplied with a thermostat-type temperature response device, as a standard. The device is a RRL2 (resettable link device), which only incorporates one thermostat and therefore the damper remains closed as soon as its sensor temperature is reached. The RRL2 does not contain blade indication switches. Refer to **Figure 9** for wiring of the RRL2 thermostat.

### Ratings

**Integral Switch Type:** Single pole, double throw

**Electrical Capacity:** 10 Amps, 1/3 hp, 120 or 240 Vac;  
 1/2 Amp, 125 Vdc;  
 1/4 Amp, 250 Vdc;  
 5 Amps, 120 Vac "L" (lamp load);  
 1 Amp, 24 Vac;  
 1.5 Amps, 24 Vdc

**Temperature Limit:** 165°F (standard primary sensor)  
 212°F (optional primary sensor)

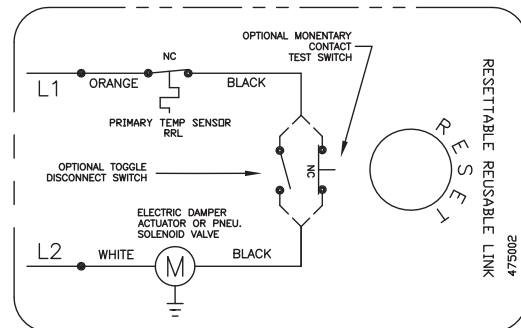

Figure 9

## Our Commitment

*As a result of our commitment to continuous improvement, Greenheck reserves the right to change specifications without notice.*

Product warranties can be found online at [Greenheck.com](http://Greenheck.com), either on the specific product page or in the literature section of the website at [Greenheck.com/Resources/Library/Literature](http://Greenheck.com/Resources/Library/Literature).

