

## Installation, Operation and Maintenance Manual

Please read and save these instructions for future reference. Read carefully before attempting to assemble, install, operate or maintain the product described. Protect yourself and others by observing all safety information. Failure to comply with these instructions will result in voiding of the product warranty and may result in personal injury and/or property damage.

CONFIGURATION: INTERIOR FLANGE  
MOUNT LOCATION: BACK/INTERIOR  
STANDARD ANCHOR LOCATION: JAMBS, DETAILS A, B, C, G AND H  
OPTIONAL ANCHOR LOCATION: HEAD AND SILL, DETAILS D, E, F, G, AND H  
(BELOW IS VIEWED FROM EXTERIOR)

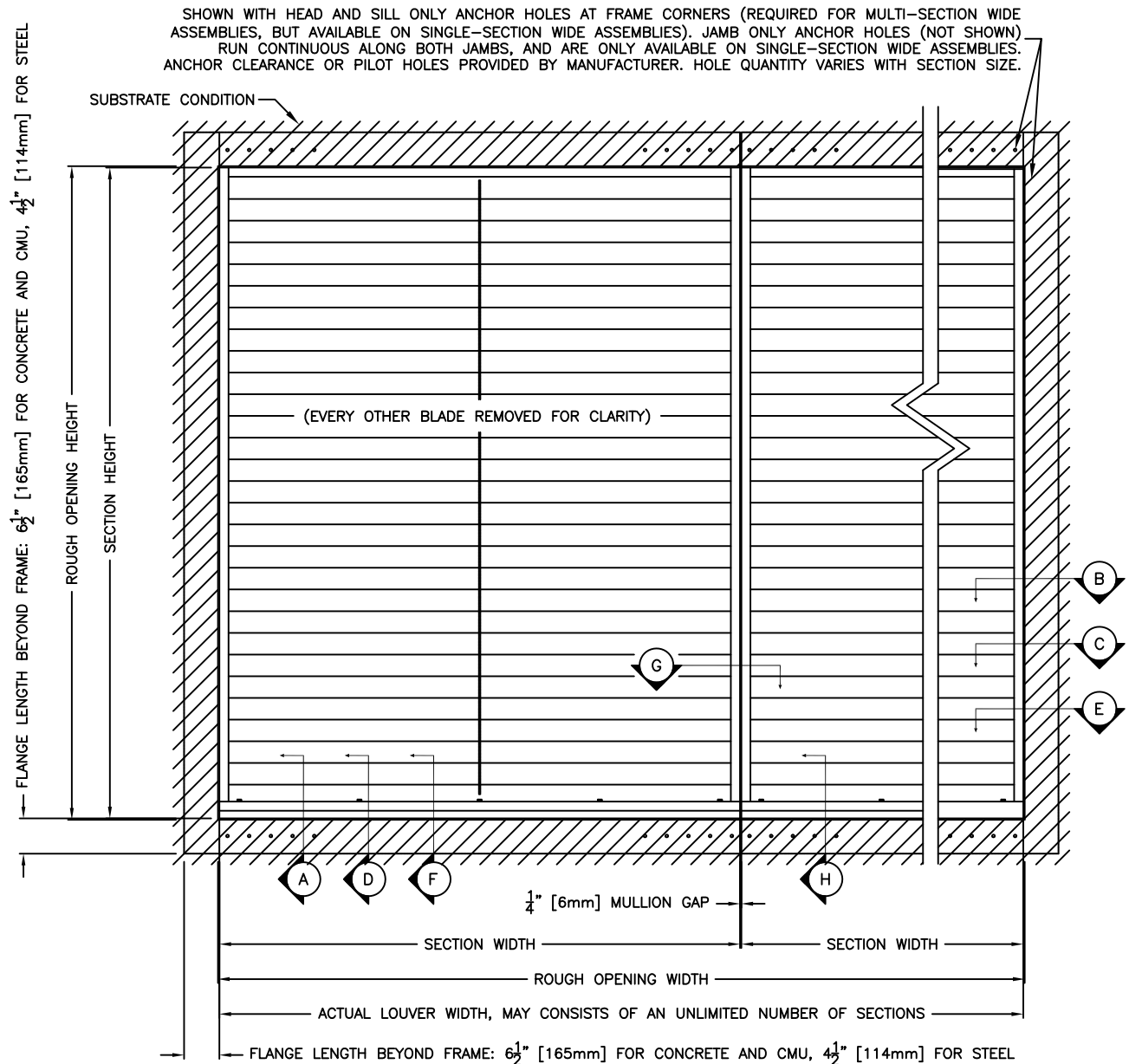

FIELD WORK: LOUVER HAS FACTORY SEALED EDGES AND JOINTS. THE SEALING NOTED HEREIN IS OPTIONAL AND MAY OR MAY NOT BE REQUIRED PER THE PROJECT'S SPECIFICATIONS. INSTALLER SHALL SEAL THE PRODUCT AND INTERFACES IN ORDER TO COMPLY WITH THE PROJECT'S SPECIFICATIONS. INSTALLER SHALL SEPARATE DISSIMILAR MATERIALS AS REQUIRED PER PROJECT'S SPECIFICATIONS. SEALANT, BACKER ROD, SHIMS, ITEMS TO SEPARATE DISSIMILAR MATERIAL, ARE NOT BY LOUVER MANUFACTURER. SILL WEEP GAPS HEREIN REFER TO AN OPTIONAL BREAK IN THE CONTINUOUS PERIMETER SEAL TO ALLOW FOR WATER DRAINAGE. SUBSTRATE MINIMUMS NOTED HEREIN ARE FOR ANCHORING OF THE LOUVER TO THE SUBSTRATE ONLY. SUBSTRATE SHALL BE VALIDATED BY THE PROJECT'S APPROPRIATE ENGINEER FOR ITS ABILITY TO MEET THE REQUIRED DESIGN PRESSURE AND/OR IMPACT RESISTANCE.

STANDARD ANCHOR LOCATION: JAMBS

OPTIONAL ANCHOR LOCATION: HEAD AND SILL

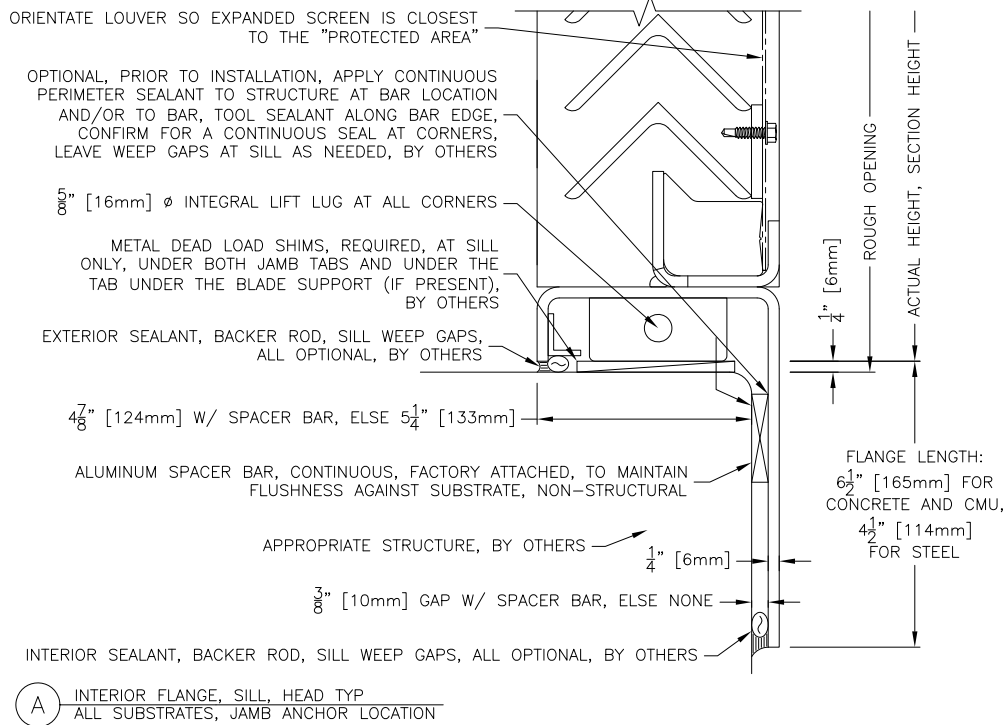
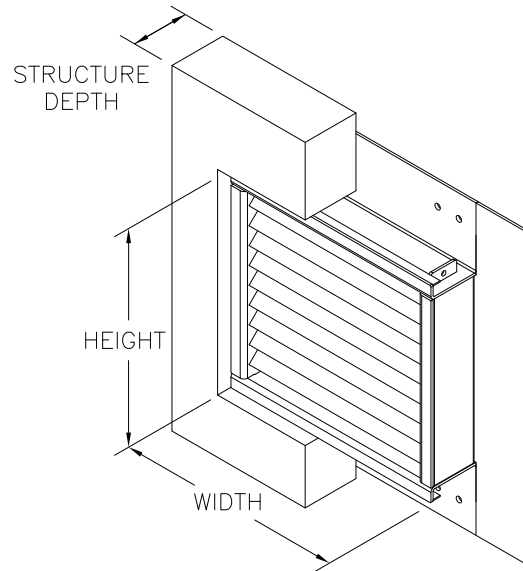
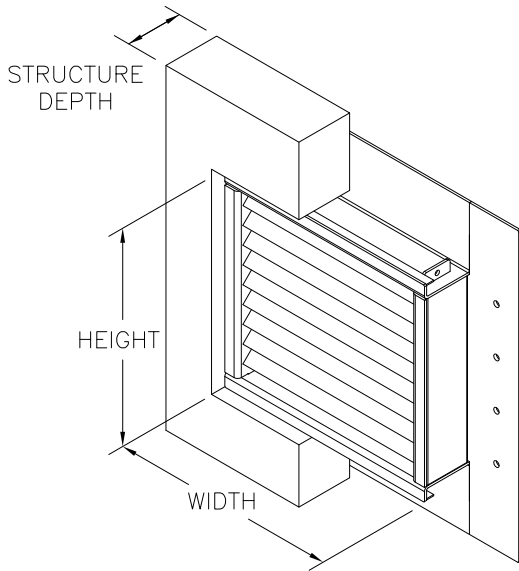

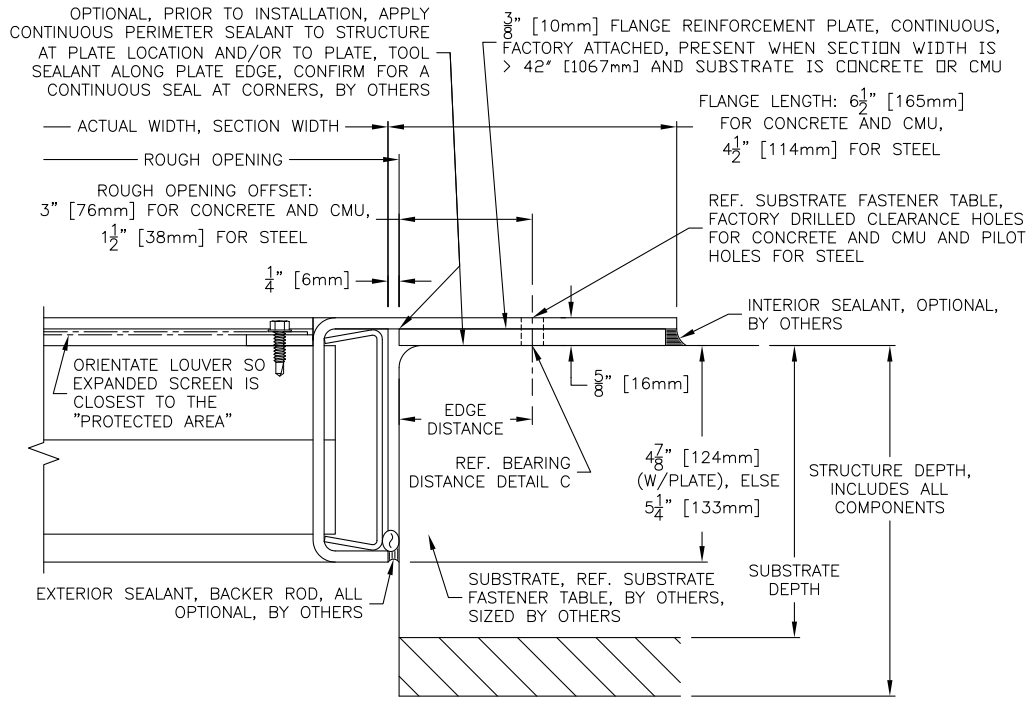

**B** INTERIOR FLANGE, JAMB, TYP  
 ALL SUBSTRATES, JAMB ANCHOR LOCATION

DETAIL B SUBSTRATE FASTENER TABLE: EXTERIOR OR INTERIOR FLANGE, JAMB ANCHOR LOCATION					
SUBSTRATE	MIN EDGE, MIN BEARING NEAR ANCHOR	CENTERS	MIN EMBEDMENT	MIN DEPTH OF SUBSTRATE COMPONENT OF STRUCTURE	OTHER
CONCRETE	3" [76mm], 1¼" [32mm] MIN BEARING TOWARD AND 2" [51mm] MIN BEARING AWAY FROM JAMB	6" [152mm]	3" [76mm]	7" [178mm]	EDGE DISTANCE OF 3" [76mm] MIN IN ONE DIRECTION AND 6" [152mm] MIN IN ALL OTHER DIRECTIONS, 3" [10mm] FLANGE REINFORCEMENT PLATE REQUIRED IF SECTION WIDTH IS > 42" [1067mm], JAMB FLANGE OR REINFORCEMENT PLATE MUST BE FULLY BACKED BY SUBSTRATE OR OTHER SUFFICIENT SUPPORT OVER NOTED BEARING DISTANCES
	½" [13mm] Ø DEWALT SCREW-BOLT+, BY OTHERS				
	SUBSTRATE REQUIREMENTS: MIN 4KSI COMPRESSIVE STRENGTH				
GROUT FILLED CMU	3" [76mm] MIN EDGE	6" [152mm]	4¼" [108mm]	8" [203mm] NOM CMU BLOCK	EDGE DISTANCE OF 3" [76mm] MIN IN ONE DIRECTION AND 8" [203mm] MIN IN ALL OTHER DIRECTIONS, 3" [10mm] FLANGE REINFORCEMENT PLATE REQUIRED IF SECTION WIDTH IS > 42" [1067mm], JAMB FLANGE OR REINFORCEMENT PLATE MUST BE FULLY BACKED BY SUBSTRATE OR OTHER SUFFICIENT SUPPORT OVER NOTED BEARING DISTANCES
	IF SECTION WIDTH IS ≤ 42" [1067mm], THEN 1¼" [32mm] MIN BEARING TOWARD JAMB AND 2" [51mm] MIN BEARING AWAY FROM JAMB, ELSE 1½" [38mm] MIN BEARING TOWARD JAMB AND 3" [76mm] MIN BEARING AWAY FROM JAMB				
	½" [13mm] Ø DEWALT SCREW-BOLT+, BY OTHERS				
SUBSTRATE REQUIREMENTS: -FULLY GROUTED CMU, 1.5 KSI [10.3 MPA] MIN COMPRESSIVE STRENGTH. -CMU BLOCK MIN: 8x8x16" [203x203x406mm] NOM, GRADE N, LIGHT OR NORMAL OR MED-WEIGHT, TYPE II, CONFORMS TO ASTM C90. -GROUT MIN: COMPRESSIVE STRENGTH OF AT LEAST EQUAL TO ITS SPECIFIED STRENGTH BUT MIN OF 2 KSI [13.8 MPA] AS TESTED PER ASTM C1019, OR ALTERNATIVELY PER SEC 3.2.2 OF ICC-ES REPORT ESR-4042.					
STEEL	1" [25mm], 1" [25mm] MIN BEARING TOWARD JAMB AND 1½" [41mm] MIN BEARING AWAY FROM JAMB	6" [152mm]	3" [5mm] FOR NUT AND BOLT, 1" [6mm] FOR TAP AND BOLT	5" [127mm], CAN BE LESS IF MIN EMBEDMENT IS SATISFIED	PILOT HOLES PROVIDED FOR ½" [13mm] (9" [14mm] MAX) Ø FIELD DRILLED HOLES, FLANGE REINFORCEMENT PLATE IS NOT REQUIRED FOR STEEL, JAMB FLANGE MUST BE FULLY BACKED BY SUBSTRATE OR OTHER SUFFICIENT SUPPORT OVER NOTED BEARING DISTANCES
	½-13 GR5 ZP OR 300 SERIES SS BOLT, w/NUT, BY OTHERS, NUT OPTIONAL IF SUBSTRATE IS TAPPED				
	SUBSTRATE REQUIREMENTS AT BOLT LOCATION: MIN A36, ANY APPROPRIATE SHAPE ALLOWED, AT BOLT LOCATION MIN 3" [5mm] FOR NUT AND BOLT OR MIN ¼" [6mm] FOR TAP AND BOLT				

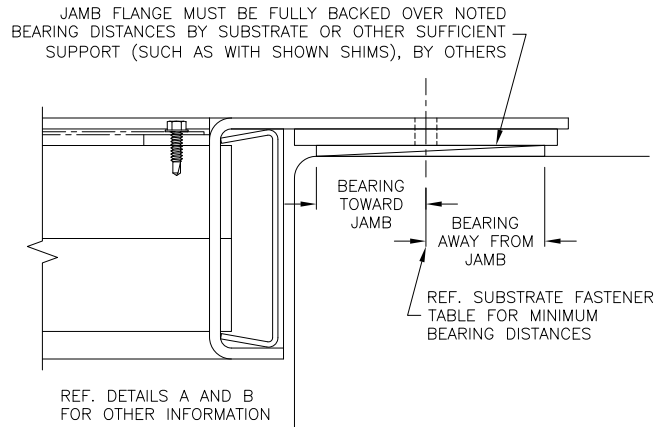

**C** INTERIOR FLANGE, BEARING DISTANCE  
ALL SUBSTRATES, JAMB ANCHOR LOCATION

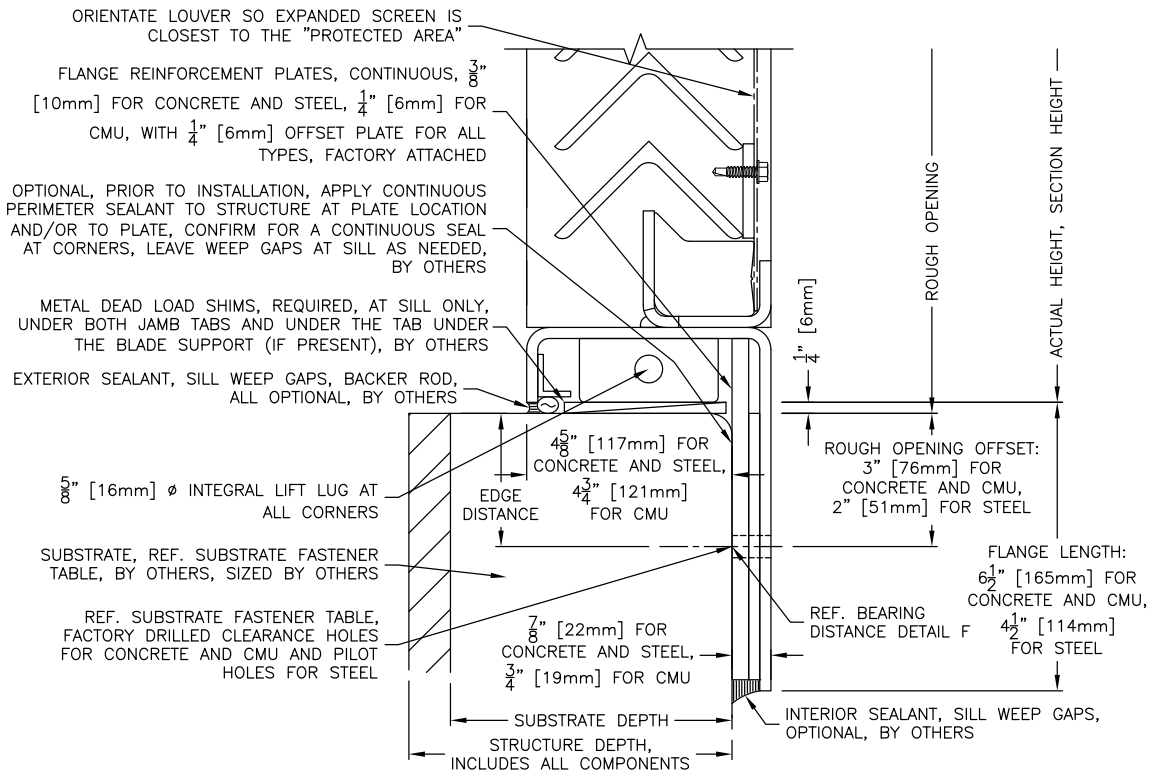

**D** INTERIOR FLANGE, SILL, HEAD TYP  
ALL SUBSTRATES, HEAD AND SILL ANCHOR LOCATION

DETAIL D SUBSTRATE FASTENER TABLE: EXTERIOR OR INTERIOR FLANGE, HEAD AND SILL ANCHOR LOCATION					
SUBSTRATE	MIN EDGE, MIN BEARING NEAR ANCHOR	CENTERS, QUANTITY	MIN EMBEDMENT	MIN DEPTH OF SUBSTRATE COMPONENT OF STRUCTURE	OTHER
CONCRETE	3" [76mm], 1½" [38mm] MIN BEARING TOWARD HEAD/SILL AND 3" [76mm] MIN BEARING AWAY FROM HEAD/SILL	7" [178mm], MAX OF 3 TOTAL AT EACH SECTION CORNER	5" [127mm]	7" [178mm]	EDGE DISTANCE OF 3" [76mm] MIN IN ONE DIRECTION AND 6" [154mm] MIN IN ALL OTHER DIRECTIONS, HEAD/SILL FLANGE REINFORCEMENT PLATE MUST BE FULLY BACKED BY SUBSTRATE OR OTHER SUFFICIENT SUPPORT OVER NOTED BEARING DISTANCES
	⅝" [16mm] Ø DEWALT SCREW-BOLT+, BY OTHERS. CALCULATE "X" TO FIND THE TOTAL # OF FASTENERS AT THE CORNER OF EACH LOUVER SECTION: $X = (\text{ACTUAL SECTION HEIGHT}) * (\text{ACTUAL SECTION WIDTH}) * (6.25/1,440)$ FOR $X \leq 8.5$ THEN 1/CORNER, FOR $X \leq 13$ THEN 2/CORNER, FOR $X \leq 20$ THEN 3/CORNER				
	SUBSTRATE REQUIREMENTS: MIN 4KSI COMPRESSIVE STRENGTH				
GROUT FILLED CMU	3" [76mm], 1½" [38mm] MIN BEARING TOWARD HEAD/SILL AND 3" [76mm] MIN BEARING AWAY FROM HEAD/SILL	4" [102mm], MAX OF 4 TOTAL AT EACH SECTION CORNER	4¼" [108mm]	8" [203mm] NOM CMU BLOCK	EDGE DISTANCE OF 3" [76mm] MIN IN ONE DIRECTION AND 8" [203mm] MIN IN ALL OTHER DIRECTIONS, HEAD/SILL FLANGE REINFORCEMENT PLATE MUST BE FULLY BACKED BY SUBSTRATE OR OTHER SUFFICIENT SUPPORT OVER NOTED BEARING DISTANCES
	½" [13mm] Ø DEWALT SCREW-BOLT+, BY OTHERS. CALCULATE "X" TO FIND THE TOTAL # OF FASTENERS AT THE CORNER OF EACH LOUVER SECTION: $X = (\text{ACTUAL SECTION HEIGHT}) * (\text{ACTUAL SECTION WIDTH}) * (6.25/1,440)$ FOR $X \leq 6$ THEN 2/CORNER, FOR $X \leq 8.5$ THEN 3/CORNER, FOR $X \leq 10$ THEN 4/CORNER				
	SUBSTRATE REQUIREMENTS: -FULLY GROUTED CMU, 1.5 KSI [10.3 MPA] MIN COMPRESSIVE STRENGTH. -CMU BLOCK MIN: 8x8x16" [203x203x406mm] NOM, GRADE N, LIGHT OR NORMAL OR MED-WEIGHT, TYPE II, CONFORMS TO ASTM C90. -GROUT MIN: COMPRESSIVE STRENGTH OF AT LEAST EQUAL TO ITS SPECIFIED STRENGTH BUT MIN OF 2 KSI [13.8 MPA] AS TESTED PER ASTM C1019, OR ALTERNATIVELY PER SEC 3.2.2 OF ICC-ES REPORT ESR-4042.				
STEEL	1" [25mm], 1" [25mm] MIN BEARING TOWARD HEAD/SILL AND 2" [51mm] MIN BEARING AWAY FROM HEAD/SILL	3" [76mm], MAX OF 3 TOTAL AT EACH SECTION CORNER	⅜" [5mm] FOR NUT AND BOLT, ¼" [6mm] FOR TAP AND BOLT	5" [127mm], CAN BE LESS IF MIN EMBEDMENT IS SATISFIED	PILOT HOLES PROVIDED FOR ½" [13mm] (⅞" [14mm] MAX) Ø FIELD DRILLED HOLES, HEAD/SILL FLANGE MUST BE FULLY BACKED BY SUBSTRATE OR OTHER SUFFICIENT SUPPORT OVER NOTED BEARING DISTANCES
	½"-13 GR5 ZP OR 300 SERIES SS BOLT, w/NUT, BY OTHERS, NUT OPTIONAL IF SUBSTRATE IS TAPPED. CALCULATE "X" TO FIND THE TOTAL # OF FASTENERS AT THE CORNER OF EACH LOUVER SECTION: $X = (\text{ACTUAL SECTION HEIGHT}) * (\text{ACTUAL SECTION WIDTH}) * (6.25/1,440)$ FOR $X \leq 6.5$ THEN 1/CORNER, FOR $X \leq 13$ THEN 2/CORNER, FOR $X \leq 20$ THEN 3/CORNER				
	SUBSTRATE REQUIREMENTS AT BOLT LOCATION: MIN A36, ANY APPROPRIATE SHAPE ALLOWED, AT BOLT LOCATION MIN ⅜" [5mm] FOR NUT AND BOLT OR MIN ¼" [6mm] FOR TAP AND BOLT				

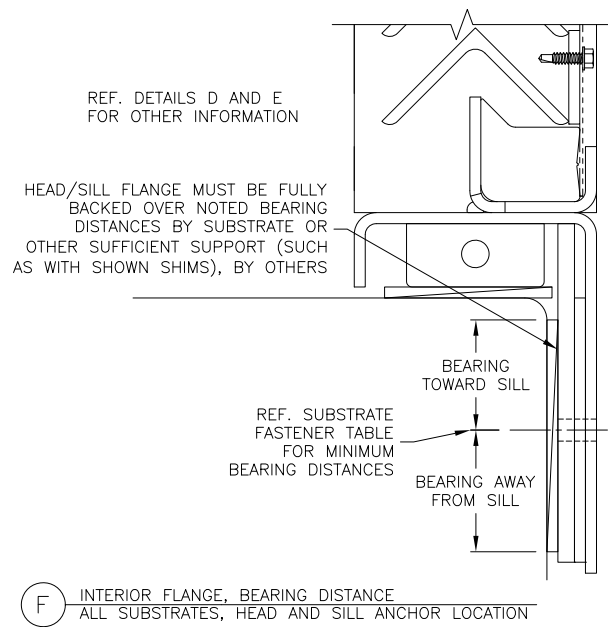
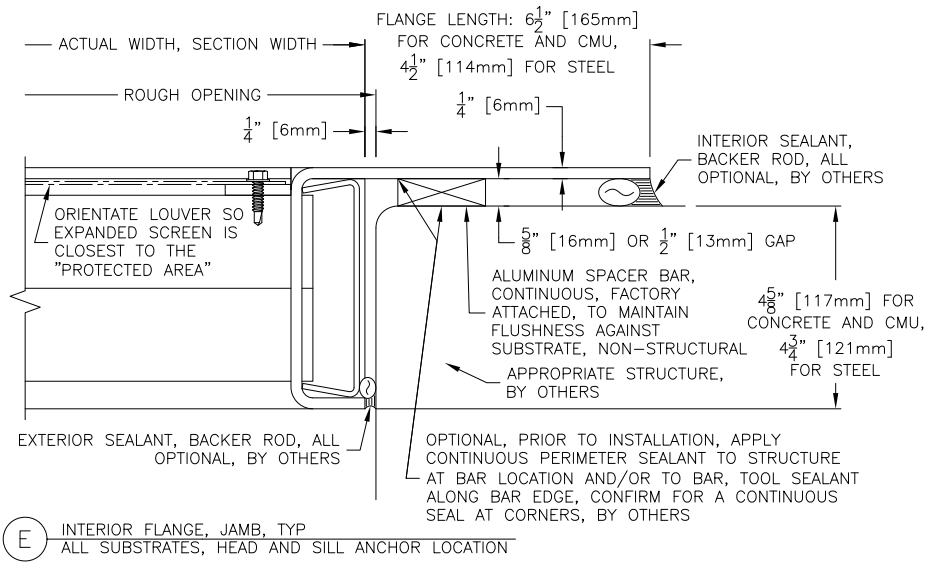

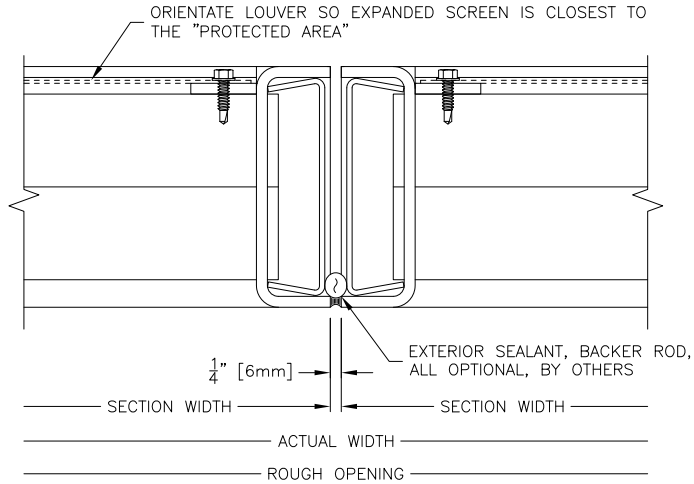

**G** INTERIOR FLANGE, MULLION  
ALL SUBSTRATES, ALL ANCHOR LOCATIONS

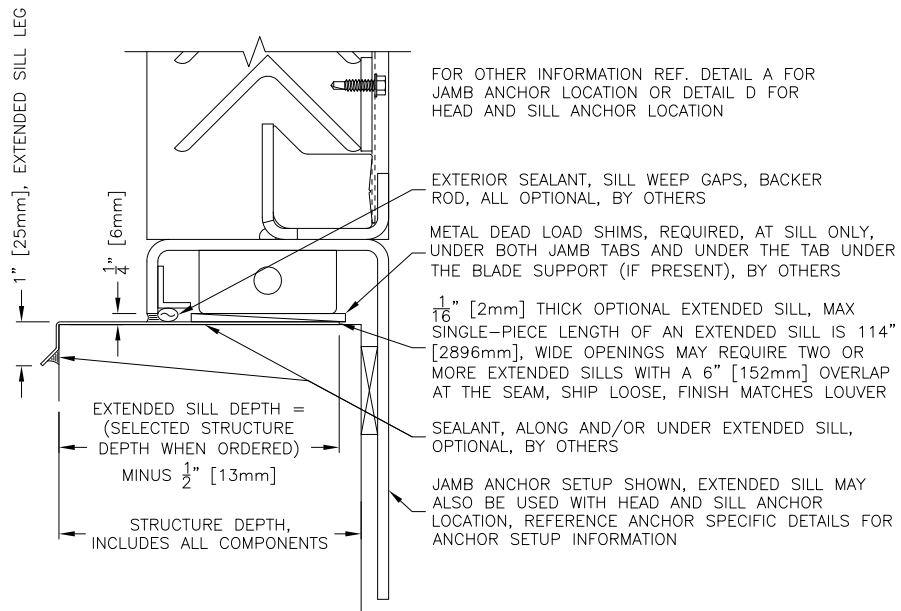

**H** INTERIOR FLANGE, OPTIONAL EXTENDED SILL  
ALL SUBSTRATES, JAMB ANCHOR LOCATION, HEAD AND SILL ANCHOR LOCATION TYP.

ALLOWABLE SECTION SIZES FOR EXTERIOR OR INTERIOR FLANGE CONFIGURATIONS					
SUBSTRATE MATERIAL	MIN STRUCTURE DEPTH (IN.)	ANCHOR LOCATION	MAX SECTION SIZE WxH (IN.)		NOTES
			MILL	FINISHED	
CONCRETE	7 OR MORE	JAMBS	54 x 120	54 x 104 48 x 116	
		HEAD AND SILL	48 x 94 72 x 64 96 x 48		
GROUT FILLED CMU	8 OR MORE	JAMBS	54 x 120	54 x 104 48 x 116	
		HEAD AND SILL	48 x 48 72 x 32		
STEEL	5 OR MORE	JAMBS	60 x 120	60 x 102 48 x 120	STRUCTURE DEPTH CAN BE LESS IF MINIMUM EMBEDMENT IS SATISFIED.
		HEAD AND SILL	48 x 94 72 x 64 96 x 48		

## Our Commitment

*As a result of our commitment to continuous improvement, Greenheck reserves the right to change specifications without notice.*

Specific Greenheck product warranties are located on [greenheck.com](http://greenheck.com) within the product area tabs and in the Library under Warranties.

