

Installation, Operation and Maintenance Manual

Please read and save these instructions for future reference. Read carefully before attempting to assemble, install, operate or maintain the product described. Protect yourself and others by observing all safety information. Failure to comply with these instructions will result in voiding of the product warranty and may result in personal injury and/or property damage.

CONFIGURATION: FLUSH MOUNT OR COSMETIC FLANGE (COSMETIC FLANGE IS THE FLUSH MOUNT CONFIGURATION WITH THE ADDITION OF NON-STRUCTURAL EXTERIOR PERIMETER FLANGES)

MOUNT LOCATION: REAR/INTERIOR

JAMB ANCHOR LOCATION: DETAILS A, B, C, G, H, J, AND K

HEAD AND SILL ANCHOR LOCATION: DETAILS D, E, F, G, H, J, AND K
(BELOW IS VIEWED FROM EXTERIOR)

HEAD AND SILL ONLY ANCHOR HOLES AT FRAME CORNERS ARE REQUIRED FOR MULTI-SECTION WIDE ASSEMBLIES, BUT AVAILABLE ON SINGLE-SECTION WIDE ASSEMBLIES. JAMB ONLY ANCHOR HOLES RUN CONTINUOUS ALONG BOTH JAMBS, AND ARE ONLY AVAILABLE ON SINGLE-SECTION WIDE ASSEMBLIES. ANCHOR CLEARANCE OR PILOT HOLES PROVIDED BY MANUFACTURER. HOLE QUANTITY VARIES WITH SECTION SIZE.

COSMETIC FLANGE:
 $4\frac{1}{2}$ " [114mm] BEYOND FRAME,
ENTIRE PERIMETER

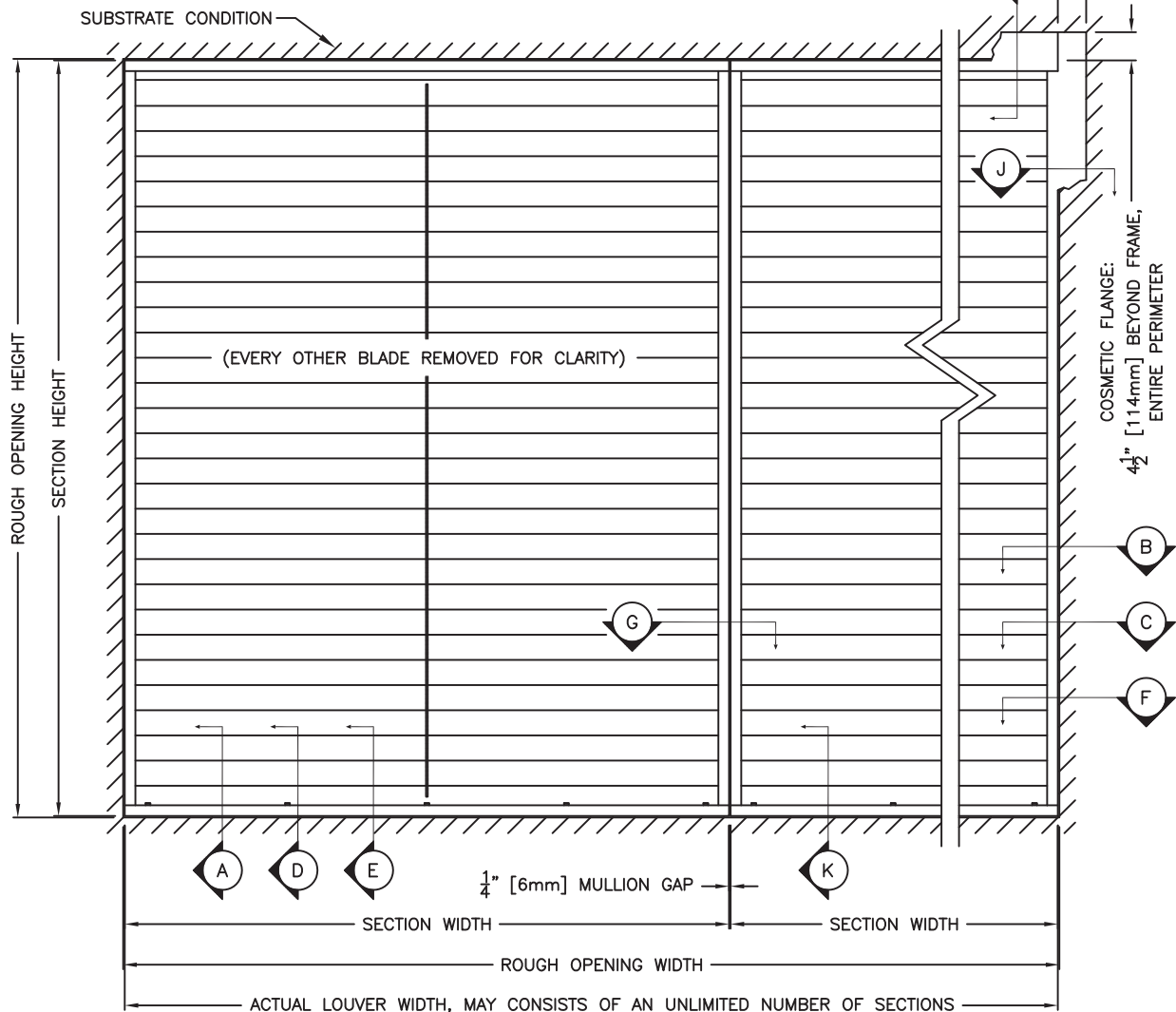

FIELD WORK: LOUVER HAS FACTORY SEALED EDGES AND JOINTS. THE SEALING NOTED HEREIN IS OPTIONAL AND MAY OR MAY NOT BE REQUIRED PER THE PROJECT'S SPECIFICATIONS. INSTALLER SHALL SEAL THE PRODUCT AND INTERFACES IN ORDER TO COMPLY WITH THE PROJECT'S SPECIFICATIONS. INSTALLER SHALL SEPARATE DISSIMILAR MATERIALS AS REQUIRED PER PROJECT'S SPECIFICATIONS. SEALANT, BACKER ROD, SHIMS, ITEMS TO SEPARATE DISSIMILAR MATERIAL, ARE NOT BY LOUVER MANUFACTURER. SILL WEEP GAPS HEREIN REFER TO AN OPTIONAL BREAK IN THE CONTINUOUS PERIMETER SEAL TO ALLOW FOR WATER DRAINAGE. SUBSTRATE MINIMUMS NOTED HEREIN ARE FOR ANCHORING OF THE LOUVER TO THE SUBSTRATE ONLY. SUBSTRATE SHALL BE VALIDATED BY THE PROJECT'S APPROPRIATE ENGINEER FOR ITS ABILITY TO MEET THE REQUIRED DESIGN PRESSURE AND/OR IMPACT RESISTANCE.

STANDARD ANCHOR LOCATION: JAMBS

OPTIONAL ANCHOR LOCATION: HEAD AND SILL

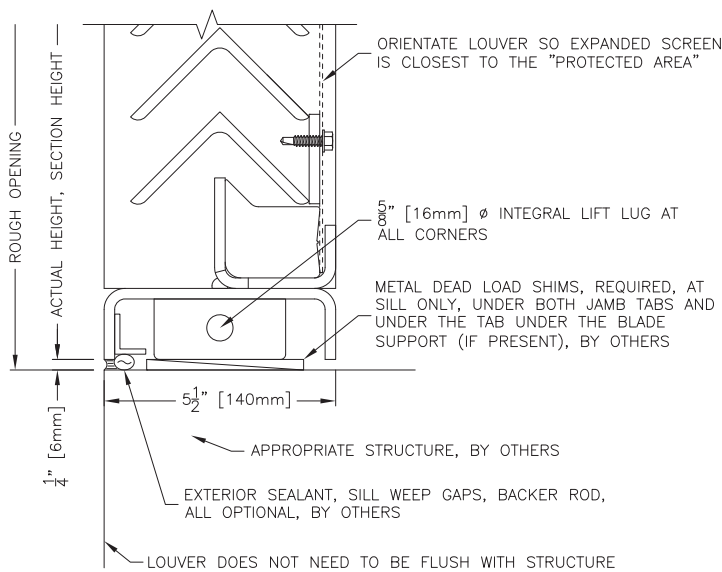
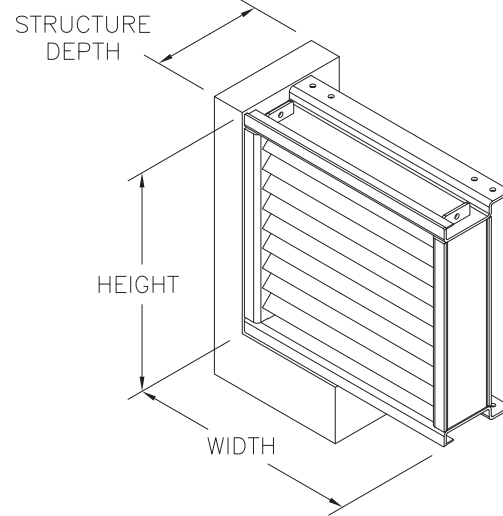
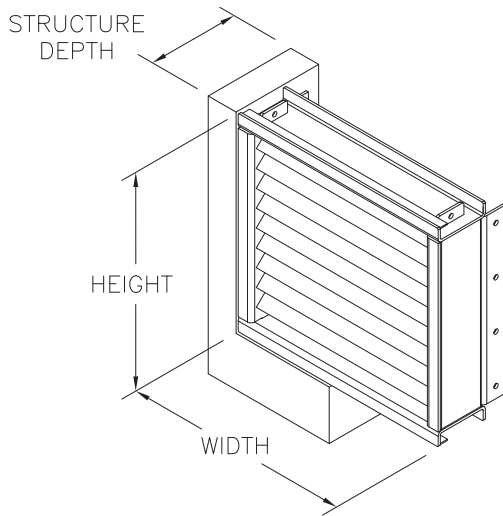

A FLUSH MOUNT OR COSMETIC FLANGE, SILL, HEAD TYP ALL SUBSTRATES, JAMB ANCHOR LOCATION

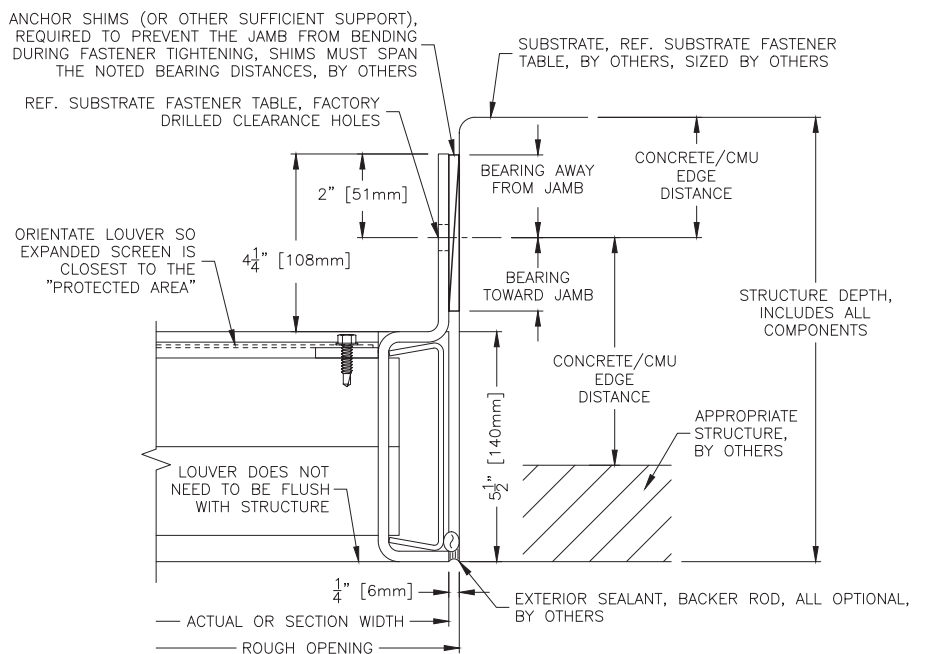

B1 FLUSH MOUNT OR COSMETIC FLANGE, JAMB, TYP CONCRETE AND CMU SUBSTRATES, JAMB ANCHOR LOCATION

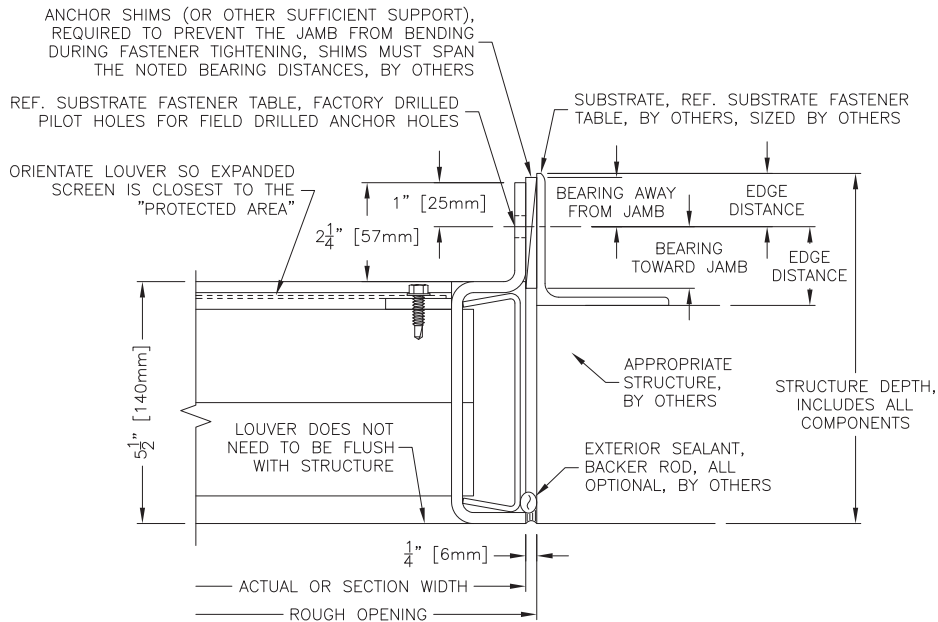

(B2) FLUSH MOUNT OR COSMETIC FLANGE, JAMB, TYP. STEEL SUBSTRATE, JAMB ANCHOR LOCATION

DETAIL B1 AND B2 SUBSTRATE FASTENER TABLE: FLUSH MOUNT OR COSMETIC FLANGE, JAMB ANCHOR LOCATION					
SUBSTRATE	MIN EDGE, MIN BEARING NEAR ANCHOR	CENTERS	MIN EMBEDMENT	MIN STRUCTURE DEPTH, INCLUDES ALL COMPONENTS	OTHER
CONCRETE	3 1/4" [83mm], 1 7/8" [48mm] MIN BEARING TOWARD AND AWAY FROM JAMB	6" [152mm]	3" [76mm]	11" [279mm], IF DEPTH IS LESS THAN MIN THEN SECONDARY MOUNTING ANGLE IS REQUIRED (REF. DETAIL C)	EDGE DISTANCE OF 3 1/4" [83mm] MIN IN TWO DIRECTIONS AND 6" [152mm] MIN IN ALL OTHER DIRECTIONS, JAMB SUBSTRATE LEG MUST BE FULLY BACKED BY SUBSTRATE OR OTHER SUFFICIENT SUPPORT OVER NOTED BEARING DISTANCES
	1/2" [13mm] Ø DEWALT SCREW-BOLT+, BY OTHERS				
	SUBSTRATE REQUIREMENTS: MIN 4KSI COMPRESSIVE STRENGTH				
GROUT FILLED CMU	3 5/8" [92mm], 1 7/8" [48mm] MIN BEARING TOWARD AND AWAY FROM JAMB	6" [152mm]	4 1/4" [108mm]	12" [305mm], IF DEPTH IS LESS THAN MIN THEN SECONDARY MOUNTING ANGLE IS REQUIRED (REF. DETAIL C)	EDGE DISTANCE OF 3 5/8" [92mm] MIN IN ONE DIRECTION AND 7 5/8" [194mm] MIN IN ALL OTHER DIRECTIONS, JAMB SUBSTRATE LEG MUST BE FULLY BACKED BY SUBSTRATE OR OTHER SUFFICIENT SUPPORT OVER NOTED BEARING DISTANCES
	1/2" [13mm] Ø DEWALT SCREW-BOLT+, BY OTHERS				
	GROUT FILLED CMU SUBSTRATE REQUIREMENTS: -FULLY GROUTED CMU, 1.5 KSI [10.3 MPA] MIN COMPRESSIVE STRENGTH. -CMU BLOCK MIN: 8x8x16" [203x203x406mm] NOM, GRADE N, LIGHT OR NORMAL OR MED-WEIGHT, TYPE II, CONFORMS TO ASTM C90. -GROUT MIN: COMPRESSIVE STRENGTH OF AT LEAST EQUAL TO ITS SPECIFIED STRENGTH BUT MIN OF 2 KSI [13.8 MPA] AS TESTED PER ASTM C1019, OR ALTERNATIVELY PER SEC 3.2.2 OF ICC-ES REPORT ESR-4042.				
STEEL	1" [25mm], 1" [25mm] MIN BEARING TOWARD AND AWAY FROM JAMB	6" [152mm]	3/16" [5mm] FOR NUT AND BOLT, 1/4" [6mm] FOR TAP AND BOLT	8" [203mm], IF DEPTH IS LESS THAN MIN THEN SECONDARY MOUNTING ANGLE IS REQUIRED (REF. DETAIL C)	PILOT HOLES PROVIDED FOR 1/2" [13mm] (9/16" [14mm] MAX) Ø FIELD DRILLED HOLES, JAMB SUBSTRATE LEG MUST BE FULLY BACKED BY SUBSTRATE OR OTHER SUFFICIENT SUPPORT OVER NOTED BEARING DISTANCES
	1/2"-13 GR5 ZP OR 300 SERIES SS BOLT, w/NUT, BY OTHERS, NUT OPTIONAL IF SUBSTRATE IS TAPPED				
	SUBSTRATE REQUIREMENTS AT BOLT LOCATION: MIN A36, ANY APPROPRIATE SHAPE ALLOWED, AT BOLT LOCATION MIN 3/16" [5mm] FOR NUT AND BOLT OR MIN 1/4" [6mm] FOR TAP AND BOLT				

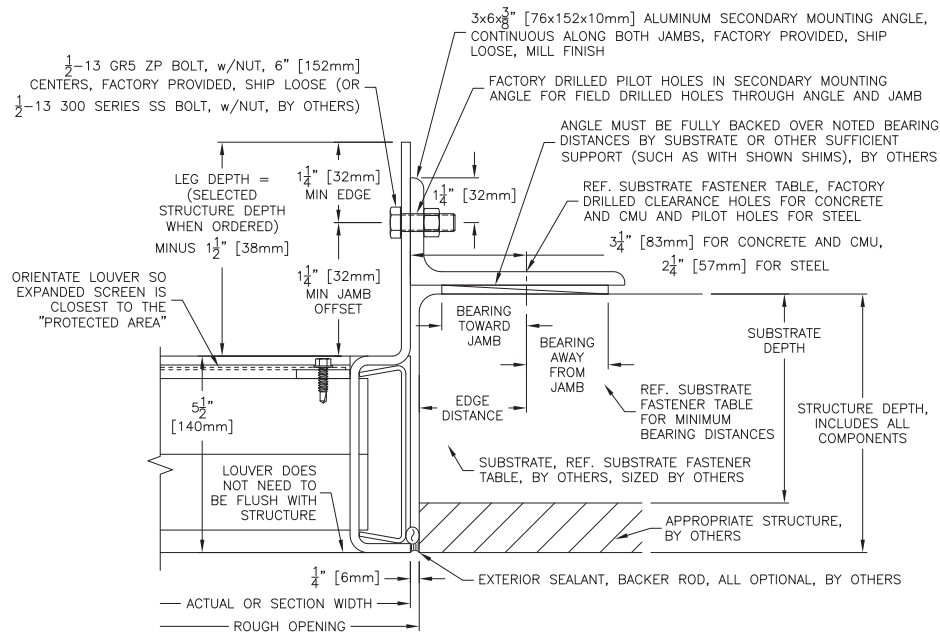

C FLUSH MOUNT OR COSMETIC FLANGE, JAMB, TYP
 ALL SUBSTRATES, JAMB ANCHOR LOCATION W/ SECONDARY MOUNTING ANGLE

DETAIL C SUBSTRATE FASTENER TABLE: FLUSH MOUNT OR COSMETIC FLANGE, JAMB ANCHOR LOCATION W/ SECONDARY MOUNTING ANGLE						
SUBSTRATE	MIN EDGE, MIN BEARING NEAR ANCHOR	CENTERS	MIN EMBEDMENT	MIN DEPTH OF SUBSTRATE COMPONENT OF STRUCTURE	MAX STRUCTURE DEPTH, INCLUDES ALL COMPONENTS	OTHER
CONCRETE	3" [76mm], 1 1/2" [38mm] MIN BEARING TOWARD JAMB AND 2 3/4" [70mm] MIN BEARING AWAY FROM JAMB	6" [152mm]	4 1/4" [108mm]	7" [178mm]	< 11" [279mm], A DEEPER STRUCTURE DOES NOT USE THE SECONDARY MOUNTING ANGLE (REF. DETAIL B1)	EDGE DISTANCE OF 3" [76mm] MIN IN ONE DIRECTION AND 6" [152mm] MIN IN ALL OTHER DIRECTIONS, JAMB LEG MUST BE FULLY BACKED BY SUBSTRATE OR OTHER SUFFICIENT SUPPORT OVER NOTED BEARING DISTANCES
	1/2" [13mm] Ø DEWALT SCREW-BOLT+, BY OTHERS					
	SUBSTRATE REQUIREMENTS: MIN 4KSI COMPRESSIVE STRENGTH					
GROUT FILLED CMU	3" [76mm], 1 1/2" [38mm] MIN BEARING TOWARD JAMB AND 2 3/4" [70mm] MIN BEARING AWAY FROM JAMB	6" [152mm]	4 1/4" [108mm]	8" [203mm] NOM CMU BLOCK	< 12" [305mm], A DEEPER STRUCTURE DOES NOT USE THE SECONDARY MOUNTING ANGLE (REF. DETAIL B1)	EDGE DISTANCE OF 3" [76mm] MIN IN ONE DIRECTION AND 8" [203mm] MIN IN ALL OTHER DIRECTIONS, JAMB LEG MUST BE FULLY BACKED BY SUBSTRATE OR OTHER SUFFICIENT SUPPORT OVER NOTED BEARING DISTANCES
	1/2" [13mm] Ø DEWALT SCREW-BOLT+, BY OTHERS					
	SUBSTRATE REQUIREMENTS: -FULLY GROUTED CMU, 1.5 KSI [10.3 MPA] MIN COMPRESSIVE STRENGTH. -CMU BLOCK MIN: 8x8x16" [203x203x406mm] NOM, GRADE N, LIGHT OR NORMAL OR MED-WEIGHT, TYPE II, CONFORMS TO ASTM C90. -GROUT MIN: COMPRESSIVE STRENGTH OF AT LEAST EQUAL TO ITS SPECIFIED STRENGTH BUT MIN OF 2 KSI [13.8 MPA] AS TESTED PER ASTM C1019, OR ALTERNATIVELY PER SEC 3.2.2 OF ICC-ES REPORT ESR-4042.					
STEEL	1" [25mm], 1" [25mm] MIN BEARING TOWARD AND AWAY FROM JAMB	6" [152mm]	3/16" [5mm] FOR NUT AND BOLT, 1/4" [6mm] FOR TAP AND BOLT	5" [127mm], CAN BE LESS IF EMBEDMENT IS SATISFIED	< 8" [203mm], A DEEPER STRUCTURE DOES NOT USE THE SECONDARY MOUNTING ANGLE (REF. DETAIL B2)	PILOT HOLES PROVIDED FOR 1/2" [13mm] (3/16" [14mm] MAX) Ø FIELD DRILLED HOLES, JAMB LEG MUST BE FULLY BACKED BY SUBSTRATE OR OTHER SUFFICIENT SUPPORT OVER NOTED BEARING DISTANCES
	1/2-13 GR5 ZP OR 300 SERIES SS BOLT, w/NUT, BY OTHERS, NUT OPTIONAL IF SUBSTRATE IS TAPPED					
	SUBSTRATE REQUIREMENTS AT BOLT LOCATION: MIN A36, ANY APPROPRIATE SHAPE ALLOWED, AT BOLT LOCATION MIN 3/16" [5mm] FOR NUT AND BOLT OR MIN 1/4" [6mm] FOR TAP AND BOLT					



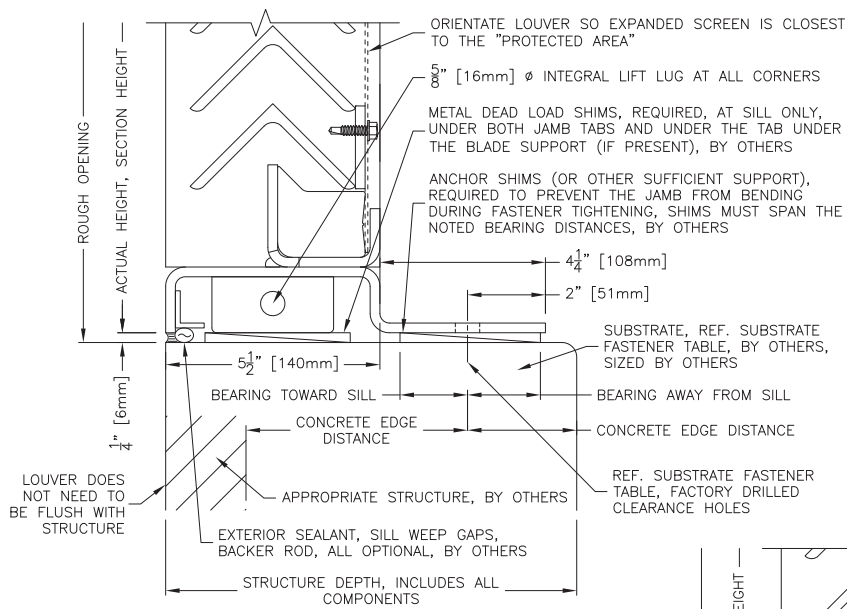

D1 FLUSH MOUNT OR COSMETIC FLANGE, SILL, HEAD TYP
CONCRETE SUBSTRATE, HEAD AND SILL ANCHOR LOCATION

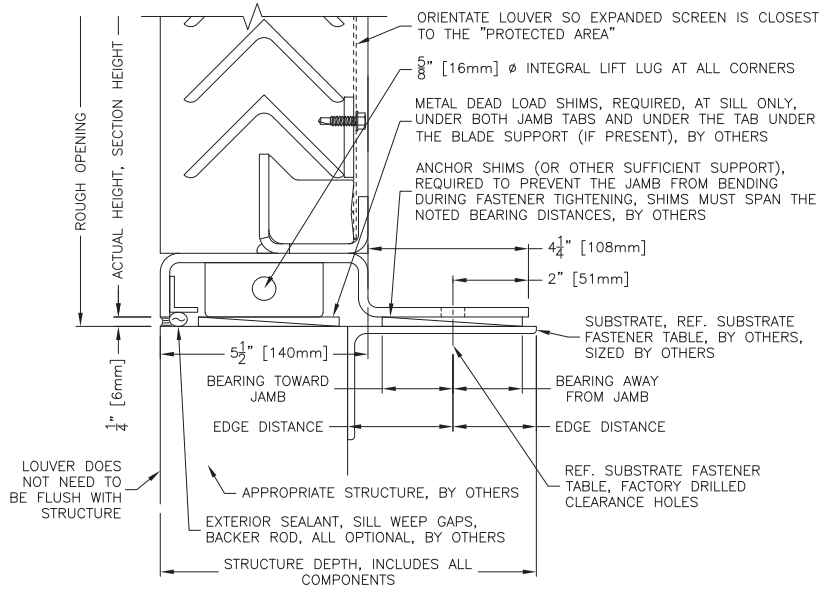

D2 FLUSH MOUNT OR COSMETIC FLANGE, SILL, HEAD TYP
STEEL SUBSTRATE, HEAD AND SILL ANCHOR LOCATION

DETAIL D1 AND D2 SUBSTRATE FASTENER TABLE: FLUSH MOUNT OR COSMETIC FLANGE, HEAD AND SILL ANCHOR LOCATION

SUBSTRATE	MIN EDGE, MIN BEARING NEAR ANCHOR	CENTERS, QUANTITY	MIN EMBEDMENT	MIN STRUCTURE DEPTH, INCLUDES ALL COMPONENTS	OTHER
CONCRETE	4" [102mm], 2" [51mm] MIN BEARING TOWARD AND AWAY FROM HEAD/SILL	6" [152mm] CENTERS, MAX OF 3 TOTAL AT EACH SECTION CORNER	4 1/4" [108mm]	12" [305mm], IF DEPTH IS LESS THAN MIN THEN SECONDARY MOUNTING ANGLE IS REQUIRED (REF. DETAIL E)	EDGE DISTANCE OF 4" [102mm] MIN IN TWO DIRECTIONS AND 6" [152mm] MIN IN ALL OTHER DIRECTIONS, HEAD/SILL SUBSTRATE LEG MUST BE FULLY BACKED BY SUBSTRATE OR OTHER SUFFICIENT SUPPORT OVER NOTED BEARING DISTANCES
	1/2" [13mm] Ø DEWALT SCREW-BOLT+, BY OTHERS. CALCULATE "X" TO FIND THE TOTAL # OF FASTENERS AT THE CORNER OF EACH LOUVER SECTION: X=(ACTUAL SECTION HEIGHT)*(ACTUAL SECTION WIDTH)*(6.25/1,440) FOR X ≤ 13 THEN 1/CORNER, FOR X ≤ 20 THEN 2/CORNER, FOR X ≤ 30 THEN 3/CORNER				
	SUBSTRATE REQUIREMENTS: MIN 4KSI COMPRESSIVE STRENGTH				
GROUT FILLED CMU	NOT AVAILABLE FOR CMU, MUST USE SECONDARY MOUNTING ANGLE SETUP (DETAIL E)				
STEEL	2" [51mm], 2" [51mm] MIN BEARING TOWARD AND AWAY FROM HEAD/SILL	4" [102mm] CENTERS, MAX OF 3 TOTAL AT EACH SECTION CORNER	3/16" [5mm] FOR NUT AND BOLT, 1/4" [6mm] FOR TAP AND BOLT	10" [254mm], IF DEPTH IS LESS THAN MIN THEN SECONDARY MOUNTING ANGLE IS REQUIRED (REF. DETAIL E)	PILOT HOLES PROVIDED FOR 1/2" [13mm] (9/16" [14mm] MAX) Ø FIELD DRILLED HOLES, HEAD/SILL SUBSTRATE LEG MUST BE FULLY BACKED BY SUBSTRATE OR OTHER SUFFICIENT SUPPORT OVER NOTED BEARING DISTANCES
	1/2"-13 GR5 ZP OR 300 SERIES SS BOLT, w/NUT, BY OTHERS, NUT OPTIONAL IF SUBSTRATE IS TAPPED. CALCULATE "X" TO FIND THE TOTAL # OF FASTENERS AT THE CORNER OF EACH LOUVER SECTION: X=(ACTUAL SECTION HEIGHT)*(ACTUAL SECTION WIDTH)*(6.25/1,440) FOR X ≤ 13 THEN 1/CORNER, FOR X ≤ 20 THEN 2/CORNER, FOR X ≤ 30 THEN 3/CORNER				
	SUBSTRATE REQUIREMENTS AT BOLT LOCATION: MIN A36, ANY APPROPRIATE SHAPE ALLOWED, AT BOLT LOCATION MIN 3/16" [5mm] FOR NUT AND BOLT OR MIN 1/4" [6mm] FOR TAP AND BOLT				

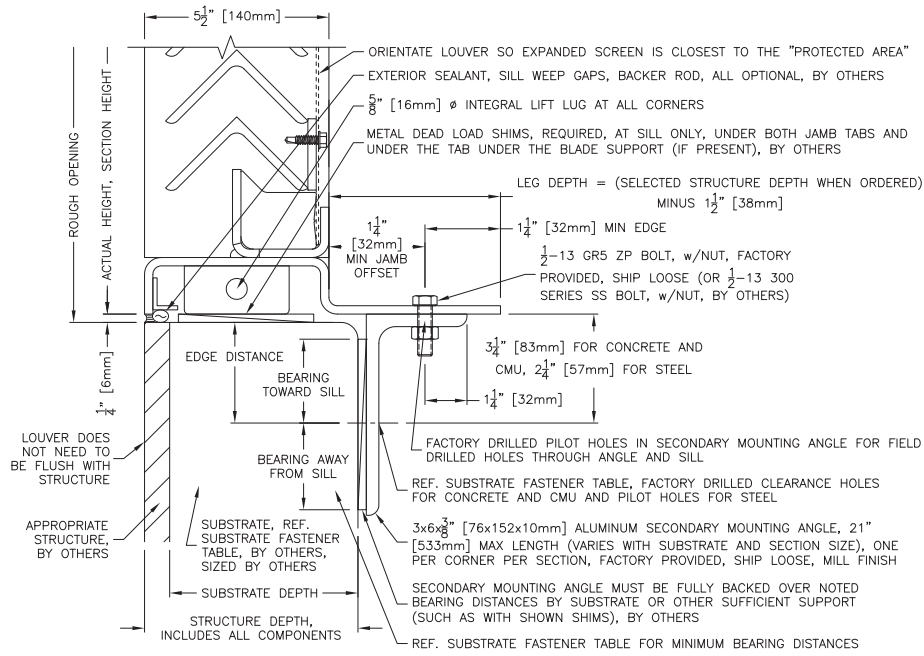

E FLUSH MOUNT OR COSMETIC FLANGE, SILL, HEAD TYP
ALL SUBSTRATES, HEAD AND SILL ANCHOR LOCATION W/ SECONDARY MOUNTING ANGLE

DETAIL E SUBSTRATE FASTENER TABLE: FLUSH MOUNT OR COSMETIC FLANGE, HEAD AND SILL ANCHOR LOCATION W/ SECONDARY MOUNTING ANGLE

SUBSTRATE	MIN EDGE, MIN BEARING NEAR ANCHOR	CENTERS, QUANTITY	MIN EMBEDMENT	MIN DEPTH OF SUBSTRATE COMPONENT OF STRUCTURE	MAX STRUCTURE DEPTH, INCLUDES ALL COMPONENTS	OTHER
CONCRETE	3" [76mm], 1 1/4" [32mm] MIN BEARING TOWARD HEAD/SILL AND 2 3/4" [70mm] MIN BEARING AWAY FROM HEAD/SILL	7" [178mm], MAX OF 3 TOTAL AT EACH SECTION CORNER	4" [102mm]	7" [178mm]	< 12" [305mm], A DEEPER STRUCTURE DOES NOT USE THE SECONDARY MOUNTING ANGLE (REF. DETAIL D1)	EDGE DISTANCE OF 3" [76mm] MIN IN ONE DIRECTION AND 5" [127mm] MIN IN ALL OTHER DIRECTIONS, SECONDARY MOUNTING ANGLE SUBSTRATE LEG MUST BE FULLY BACKED BY SUBSTRATE OR OTHER SUFFICIENT SUPPORT OVER NOTED BEARING DISTANCES
	5/8" [16mm] Ø DEWALT SCREW-BOLT+, BY OTHERS. CALCULATE "X" TO FIND THE TOTAL # OF FASTENERS AT THE CORNER OF EACH LOUVER SECTION: $X = (\text{ACTUAL SECTION HEIGHT}) * (\text{ACTUAL SECTION WIDTH}) * (6.25/1,440)$ FOR $X \leq 7.5$ THEN 1/CORNER, FOR $X \leq 14.25$ THEN 2/CORNER, FOR $X \leq 20$ THEN 3/CORNER					
	SUBSTRATE REQUIREMENTS: MIN 4KSI COMPRESSIVE STRENGTH					
GROUT FILLED CMU	3" [76mm], 1 1/4" [32mm] MIN BEARING TOWARD HEAD/SILL AND 2 3/4" [70mm] MIN BEARING AWAY FROM HEAD/SILL	4" [102mm], MAX OF 4 TOTAL AT EACH SECTION CORNER	4 1/4" [108mm]	8" [203mm] NOM CMU BLOCK	< 17" [432mm] (CONSULT MANUFACTURER IF STRUCTURE IS DEEPER AS A NON-STANDARD SETUP WILL BE REQUIRED)	EDGE DISTANCE OF 3" [76mm] MIN IN ONE DIRECTION AND 8" [203mm] MIN IN ALL OTHER DIRECTIONS, SECONDARY MOUNTING ANGLE SUBSTRATE LEG MUST BE FULLY BACKED BY SUBSTRATE OR OTHER SUFFICIENT SUPPORT OVER NOTED BEARING DISTANCES
	1/2" [13mm] Ø DEWALT SCREW-BOLT+, BY OTHERS. CALCULATE "X" TO FIND THE TOTAL # OF FASTENERS AT THE CORNER OF EACH LOUVER SECTION: $X = (\text{ACTUAL SECTION HEIGHT}) * (\text{ACTUAL SECTION WIDTH}) * (6.25/1,440)$ FOR $X \leq 3.5$ THEN 1/CORNER, FOR $X \leq 7.5$ THEN 2/CORNER, FOR $X \leq 11$ THEN 3/CORNER, FOR $X \leq 15$ THEN 4/CORNER					
	SUBSTRATE REQUIREMENTS: -FULLY GROUTED CMU, 1.5 KSI [10.3 MPA] MIN COMPRESSIVE STRENGTH. -CMU BLOCK MIN: 8x8x16" [203x203x406mm] NOM, GRADE N, LIGHT OR NORMAL OR MED-WEIGHT, TYPE II, CONFORMS TO ASTM C90. -GROUT MIN: COMPRESSIVE STRENGTH OF AT LEAST EQUAL TO ITS SPECIFIED STRENGTH BUT MIN OF 2 KSI [13.8 MPA] AS TESTED PER ASTM C1019, OR ALTERNATIVELY PER SEC 3.2.2 OF ICC-ES REPORT ESR-4042.					
STEEL	1" [25mm], 1" [25mm] MIN BEARING TOWARD HEAD/SILL AND 2 1/4" [57mm] MIN BEARING AWAY FROM HEAD/SILL	5" [127mm], MAX OF 3 TOTAL AT EACH SECTION CORNER	3/16" [5mm] FOR NUT AND BOLT, 1/4" [6mm] FOR TAP AND BOLT	5" [127mm], CAN BE LESS IF EMBEDMENT IS SATISFIED	< 10" [254mm], A DEEPER STRUCTURE DOES NOT USE THE SECONDARY MOUNTING ANGLE (REF. DETAIL D2)	PILOT HOLES PROVIDED FOR 1/2" [13mm] (9/16" [14mm] MAX) Ø FIELD DRILLED HOLES, SECONDARY MOUNTING ANGLE SUBSTRATE LEG MUST BE FULLY BACKED BY SUBSTRATE OR OTHER SUFFICIENT SUPPORT OVER NOTED BEARING DISTANCES
	1/2-13 GR5 ZP OR 300 SERIES SS BOLT, w/NUT, BY OTHERS, NUT OPTIONAL IF SUBSTRATE IS TAPPED. CALCULATE "X" TO FIND THE TOTAL # OF FASTENERS AT THE CORNER OF EACH LOUVER SECTION: $X = (\text{ACTUAL SECTION HEIGHT}) * (\text{ACTUAL SECTION WIDTH}) * (6.25/1,440)$ FOR $X \leq 9.2$ THEN 1/CORNER, FOR $X \leq 14.25$ THEN 2/CORNER, FOR $X \leq 20$ THEN 3/CORNER					
	SUBSTRATE REQUIREMENTS AT BOLT LOCATION: MIN A36, ANY APPROPRIATE SHAPE ALLOWED, AT BOLT LOCATION MIN 3/16" [5mm] FOR NUT AND BOLT OR MIN 1/4" [6mm] FOR TAP AND BOLT					

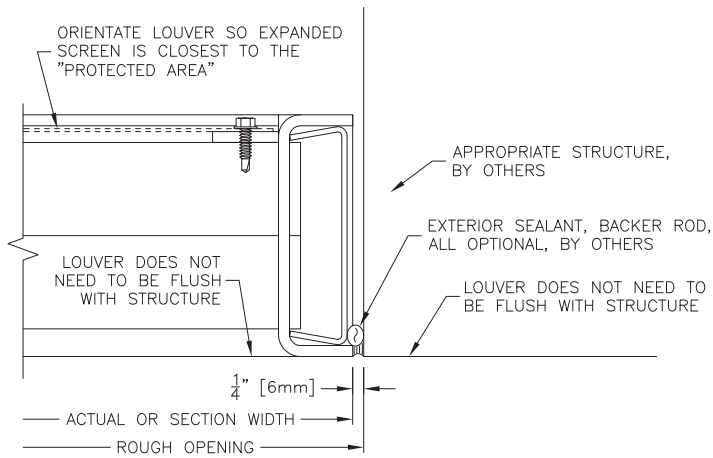

F FLUSH MOUNT OR COSMETIC FLANGE, JAMB, TYP
ALL SUBSTRATES, HEAD AND SILL ANCHOR LOCATION

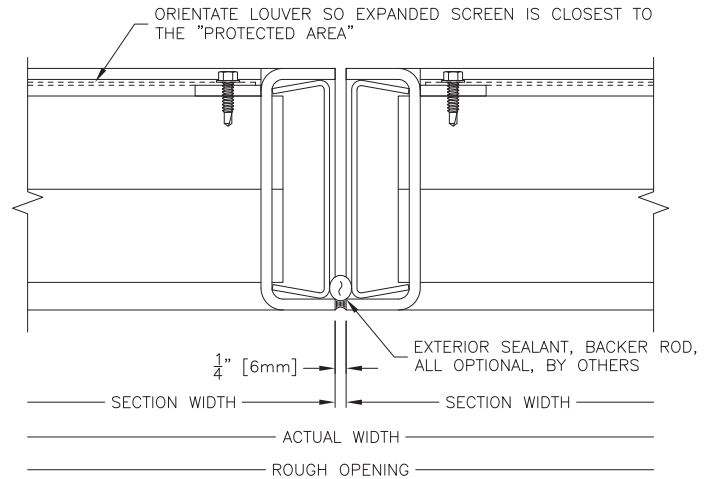

G FLUSH MOUNT OR COSMETIC FLANGE, MULLION
ALL SUBSTRATES, ALL ANCHOR LOCATIONS

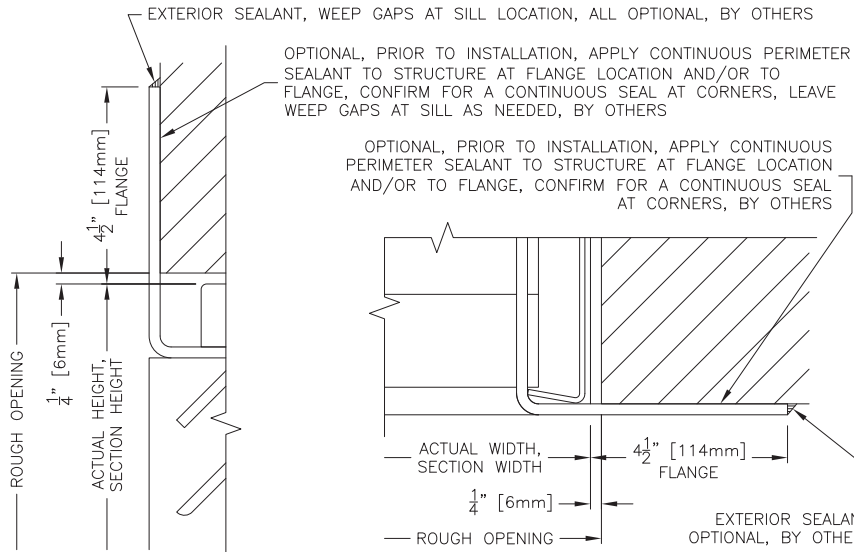

H COSMETIC FLANGE, HEAD, SILL TYP
ALL SUBSTRATES, ALL ANCHOR LOCATIONS

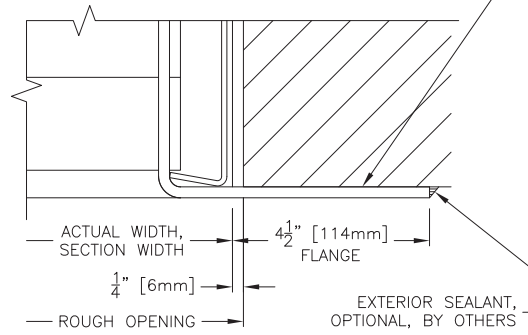

J COSMETIC FLANGE, JAMB, TYP
ALL SUBSTRATES, ALL ANCHOR LOCATIONS

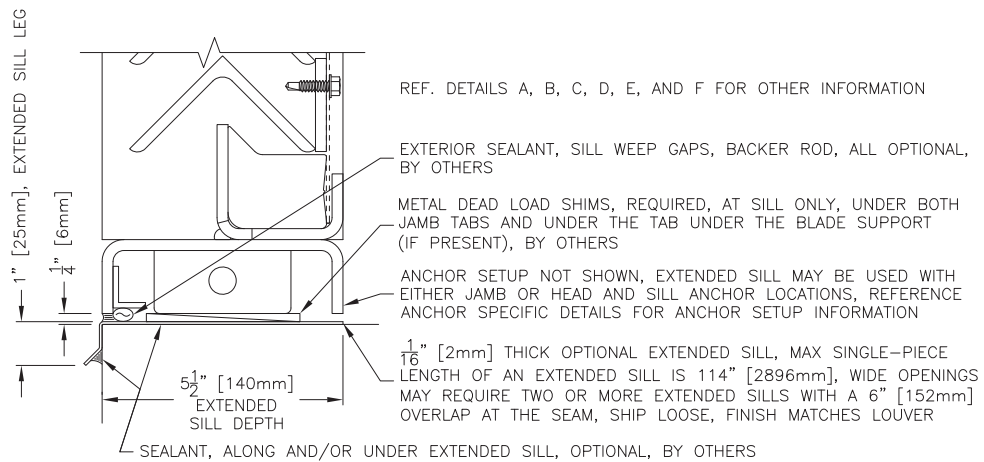

K FLUSH MOUNT, OPTIONAL EXTENDED SILL
ALL SUBSTRATES, ALL ANCHOR LOCATIONS

ALLOWABLE SECTION SIZES FOR FLUSH MOUNT CONFIGURATION					
SUBSTRATE MATERIAL	MIN STRUCTURE DEPTH (IN.)	ANCHOR LOCATION	MAX SECTION SIZE WxH (IN.)		NOTES
			MILL	FINISHED	
CONCRETE	7 OR MORE	JAMBS	60 x 120		WALL DEPTH < 11 IN. REQUIRES SECONDARY MOUNTING ANGLE.
		HEAD AND SILL	48 x 94 72 x 76 (1) 96 x 66		WALL DEPTH < 12 IN. REQUIRES SECONDARY MOUNTING ANGLE. (1) HEIGHT REDUCED TO 64 IN. IF SECONDARY MOUNTING ANGLE IS REQUIRED.
GROUT FILLED CMU	8 OR MORE	JAMBS	60 (2) x 120		WALL DEPTH < 12 IN. REQUIRES SECONDARY MOUNTING ANGLE. (2) WIDTH REDUCED TO 48 IN. IF SECONDARY MOUNTING ANGLE IS REQUIRED.
		HEAD AND SILL	48 x 72 72 x 48 96 x 36		SECONDARY MOUNTING ANGLE IS ALWAYS REQUIRED.
STEEL	5 OR MORE	JAMBS	60 x 120		WALL DEPTH < 8 IN. REQUIRES SECONDARY MOUNTING ANGLE.
		HEAD AND SILL	48 x 94 72 x 76 (3) 96 x 66 (4)		WALL DEPTH < 10 IN. REQUIRES SECONDARY MOUNTING ANGLE. (3) HEIGHT REDUCED TO 64 IN. IF SECONDARY MOUNTING ANGLE IS REQUIRED. (4) HEIGHT REDUCED TO 48 IN. IF SECONDARY MOUNTING ANGLE IS REQUIRED.

ALLOWABLE SECTION SIZES FOR COSMETIC FLANGE CONFIGURATION					
SUBSTRATE MATERIAL	MIN STRUCTURE DEPTH (IN.)	ANCHOR LOCATION	MAX SECTION SIZE WxH (IN.)		NOTES
			MILL	FINISHED	
CONCRETE	7 OR MORE	JAMBS	60 x 120	60 x 112	WALL DEPTH < 11 IN. REQUIRES SECONDARY MOUNTING ANGLE.
		HEAD AND SILL	48 x 94		WALL DEPTH < 12 IN. REQUIRES SECONDARY MOUNTING ANGLE. (1) HEIGHT REDUCED TO 64 IN. IF SECONDARY MOUNTING ANGLE IS REQUIRED.
			72 x 76 (1)	72 x 68 (1)	
GROUT FILLED CMU	8 OR MORE	JAMBS	60 (2) x 120	60 (2) x 112	WALL DEPTH < 12 IN. REQUIRES SECONDARY MOUNTING ANGLE. (2) WIDTH REDUCED TO 48 IN. IF SECONDARY MOUNTING ANGLE IS REQUIRED.
		HEAD AND SILL	48 x 72 72 x 48 96 x 36		SECONDARY MOUNTING ANGLE IS ALWAYS REQUIRED.
STEEL	5 OR MORE	JAMBS	60 x 120	60 x 112	
		HEAD AND SILL	48 x 94		WALL DEPTH < 10 IN. REQUIRES SECONDARY MOUNTING ANGLE. (3) HEIGHT REDUCED TO 64 IN. IF SECONDARY MOUNTING ANGLE IS REQUIRED. (4) HEIGHT REDUCED TO 48 IN. IF SECONDARY MOUNTING ANGLE IS REQUIRED.
			72 x 76 (3)	72 x 68 (3)	
			96 x 66 (4)		

Our Commitment

As a result of our commitment to continuous improvement, Greenheck reserves the right to change specifications without notice.

Specific Greenheck product warranties are located on greenheck.com within the product area tabs and in the Library under Warranties.

