

Installation, Operation and Maintenance Manual

Please read and save these instructions for future reference. Read carefully before attempting to assemble, install, operate or maintain the product described. Protect yourself and others by observing all safety information. Failure to comply with these instructions will result in voiding of the product warranty and may result in personal injury and/or property damage.

! IMPORTANT: DC fans must be installed with the supplied CAT-5e communication cable or shielded CAT-5e (by others) that complies with the following specifications. Cable must be twisted pair, shielded 26 ga. CAT-5e cable with a drain wire and must be compliant with ISO 11801. Cable must use shielded RJ45 connectors with a soldered drain and wiring configuration must follow EIA/TIA T568B wiring pinout. Individual CAT-5e cable lengths must not exceed 200 ft. in order to prevent network communication issues.



Model DC high volume, low speed ceiling fans are ideal for providing year-round comfort in air circulation and destratification applications. Designed for commercial spaces with low to medium height ceilings, model DC provides quiet, comfortable air movement that maximizes building efficiency by reducing load on the HVAC system. The DC's light-weight direct drive motor and compact design also result in effortless installation, making the DC a smart choice for any space.

General Safety Information

IMPORTANT: To reduce the risk of fire, electric shock or injury to persons, Model DC fans must be installed with a mount assembly, motor assembly, and airfoils that are marked (on their cartons) to indicate suitability with this model. Other mounts, motors, and airfoils cannot be substituted.

WARNING

This appliance can be used by children aged from 8 years and above and persons with reduced physical, sensory or mental capabilities or lack of experience and knowledge if they have been given supervision or instruction concerning use of the appliance in a safe way and understand the hazards involved. Children shall not play with the appliance. Cleaning and user maintenance shall not be made by children without supervision.

DANGER

Always disconnect, lock and tag power source before installing or servicing. Failure to disconnect power source can result in fire, shock or serious injury.

CAUTION

When servicing the fan, motor may be hot enough to cause pain or injury. Allow motor to cool before servicing.

CAUTION

Precaution should be taken in explosive atmospheres.

AVERTISSEMENT
Cet appareil peut être utilisé par des enfants âgés de 8 ans et plus et par des personnes aux capacités physiques, sensorielles ou mentales réduites ou qui manquent d'expérience et de connaissances s'ils sont surveillés ou ont reçu des instructions concernant l'utilisation sécuritaire de l'appareil et comprennent les risques encourus. Les enfants ne doivent pas jouer avec l'appareil. Le nettoyage et l'entretien par l'utilisateur ne doivent pas être effectués par des enfants sans surveillance.
DANGER
Pour écarter les risques d'incendie, de choc électrique ou de blessure grave, veiller à toujours débrancher, verrouiller et étiqueter la source de courant avant l'installation ou l'entretien.
ATTENTION
Lors de toute intervention sur la soufflante, le moteur peut être suffisamment chaud pour provoquer une douleur voire une blessure. Laisser le moteur refroidir avant toute maintenance.
ATTENTION
Faire preuve de précaution dans les atmosphères explosives.

Only qualified personnel should install this fan. Personnel should have a clear understanding of these instructions and should be aware of general safety precautions. Improper installation can result in electric shock, possible injury due to coming in contact with moving parts, as well as other potential hazards. Other considerations may be required if high winds or seismic activity are present. If more information is needed, contact a licensed professional engineer before moving forward.

1. Follow all local electrical and safety codes, as well as the National Electrical Code (NEC) and the National Fire Protection Agency (NFPA), where applicable. Follow the Canadian Electric Code (CEC) in Canada.
2. The rotation of the impeller is critical. It must be free to rotate without striking or rubbing any stationary objects.
3. Motor must be securely and adequately grounded.
4. Do not allow the power cable to kink or come in contact with oil, grease, hot surfaces or chemicals. Replace cord immediately if damaged.
5. Verify that the power source is compatible with the equipment.

Receiving

Upon receiving the product, check to ensure all items are accounted for by referencing the delivery receipt or packing list. Inspect each crate or carton for shipping damage before accepting delivery. Alert the carrier of any damage detected. The customer will note damage

(or shortage of items) on the delivery receipt and all copies of the bill of lading which is countersigned by the delivering carrier. If damaged, contact your local representative immediately. Any physical damage to the unit after acceptance is not the responsibility of the manufacturer.

Unpacking

Verify that all required parts and the correct quantity of each item have been received using the component list on pages 5-6. If any items are missing, report shortages to your local representative to arrange for obtaining missing parts. Sometimes it is not possible that all items for the unit be shipped together due to availability of transportation and truck space. Confirmation of shipment(s) must be limited to only items on the bill of lading.

Storage

Fans are protected against damage during shipment. If the unit cannot be installed and operated immediately, precautions need to be taken to prevent deterioration of the unit during storage. The user assumes responsibility of the fan and accessories while in storage. The manufacturer will not be responsible for damage during storage. These suggestions are provided solely as a convenience to the user.

Indoor - The ideal environment for the storage of fans and accessories is indoors, above grade, in a low humidity atmosphere that is sealed to prevent the entry of blowing dust, rain or snow. Temperatures should be evenly maintained between 30° to 110°F (-1° to 43°C). Wide temperature swings may cause condensation and “sweating” of metal parts. All accessories must be stored indoors in a clean, dry atmosphere.

Remove any accumulations of dirt, water, ice or snow and wipe dry before moving to indoor storage. To avoid “sweating” of metal parts, allow cold parts to reach room temperature. To dry parts and packages, use a portable electric heater to get rid of any moisture build up. Leave coverings loose to permit air circulation and to allow for periodic inspection.

The unit should be stored at least 3-1/2 in. (89 mm) off the floor on wooden blocks covered with moisture proof paper or polyethylene sheathing. Aisles between parts and along all walls should be provided to permit air circulation and space for inspection.

Inspection & Maintenance During Storage

While in storage, inspect fans once per month. Keep a record of inspection and maintenance performed.

If moisture or dirt accumulations are found on parts, the source should be located and eliminated. If paint deterioration begins, consideration should be given to touch-up or repainting. Fans with special coatings may require special techniques for touch-up or repair.

Machined parts coated with rust preventive should be restored to good condition promptly if signs of rust occur. Immediately remove the original rust preventive

coating with petroleum solvent and clean with lint free cloths. Polish any remaining rust from surface with crocus cloth or fine emery paper and oil. Do not destroy the continuity of the surfaces. Thoroughly wipe clean with Tectyl® 506 (Ashland Inc.) or the equivalent. For hard to reach internal surfaces or for occasional use, consider using Tectyl® 511M Rust Preventive, WD-40® or the equivalent.

Removing from Storage

As fans are removed from storage to be installed in their final location, they should be protected and maintained in a similar fashion until the fan equipment goes into operation.

Pre-Installation Checks

IMPORTANT: Consult all applicable national, state and local codes to ensure that all necessary code requirements are met. It is the sole responsibility of the installer to ensure compliance with applicable codes.

Prior to installing the fan, perform each of the following checks:

1. Verify that fan components are undamaged. Do not install or operate any damaged fan components, fans, or fan accessories. Failure to comply with this instruction may result in property damage, personal injury and/or death.
2. Verify that the fan is to be installed in a location where the airfoils will be a minimum of 10 ft. above the finished floor with a minimum of 3 ft. of clearance to any obstructions.
3. Verify that the fan is to be installed in a location where the center of the fan is a minimum of 1.5 fan diameters away from building walls and corners.
4. For best performance, the fan must be installed with a two fan diameter minimum clearance to radiant heaters and HVAC system discharges or intakes.
5. Check that the fan will not be mounted in a location near overhead doors or other building openings where gusts of wind may occur. Fan should not be installed or operated in locations where wind is present.
6. If the building is equipped with a fire sprinkler system, verify that the placement of the fan will not interfere with correct sprinkler operation and that the fan installation complies with all national, state and local codes. For NFPA 13 compliance, fan must be installed in the center of four adjacent sprinklers with at least 3 ft. of vertical clearance between the fan and sprinkler deflectors. Fan must also be interlocked to shut down upon receiving a waterflow signal from the building's alarm system.
7. Check to see if the intended placement of the fan is directly below any building lights or skylights. If possible, avoid installing fan directly below a light source to prevent a strobing effect that can be caused by fan rotation.
8. If the building has a mezzanine or other elevated spaces that may be occupied by people, verify that no component of the fan can be reached from the highest level or deck. The fan must be positioned so that the tips of the airfoils are a minimum of 3 ft. away from the furthest point that a person could reach or otherwise come in contact, to prevent injury.
9. If the fan is to be mounted in an area where materials or equipment may be elevated into its path, ensure that the floor is marked or painted to alert personnel of the overhead location of the fan(s).
10. Before installation, it is important to verify that the mounting surface will bear the operating weight and maximum torque (twisting force) of the unit. The Structural Engineer of Record (SEOR) must perform a thorough evaluation of the mounting structure and determine all final mounting requirements before the fan is installed. It is the sole responsibility of the installer to ensure that the mounting structure and fan installation method are adequate for safe operation of the fan.

DC-5 Fan Size (ft.)	*Max. Fan Weight (lbs)	Max Torque (ft·lbf)
8	112	8.3
10	119	11.1
12	126	11.8
14	135	11.9

*Maximum weight is shown in pounds and includes all available options, actual fan weight may be less.

Minimum Spacing Requirements

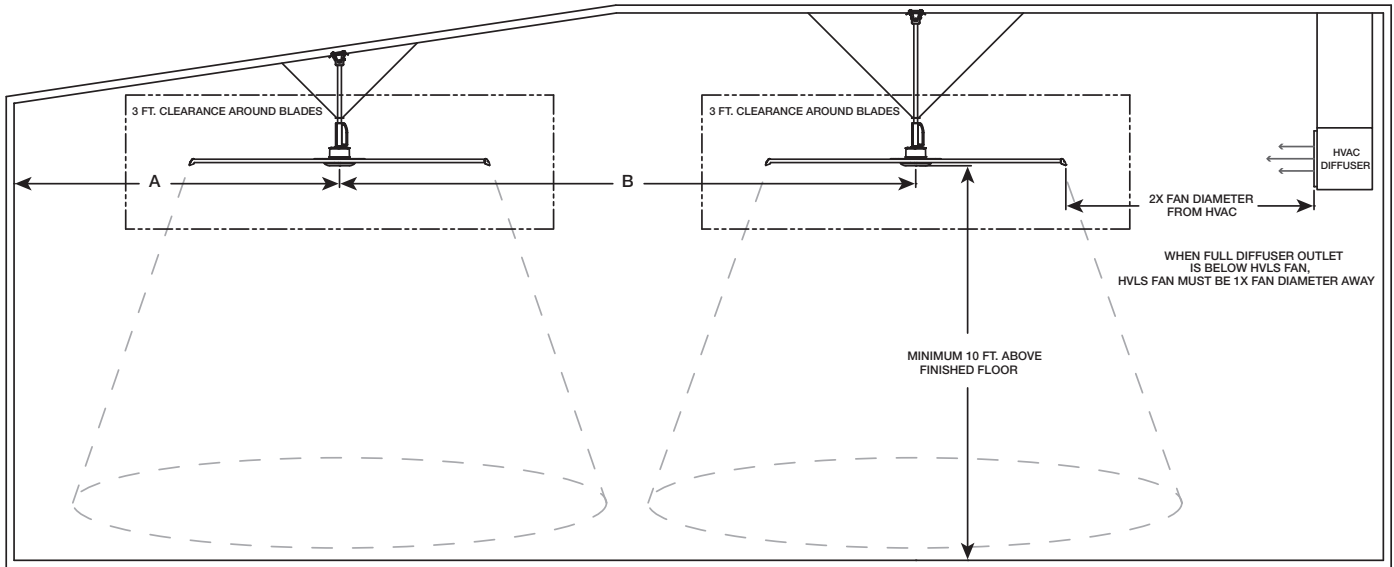

Fan Size (ft.)	Minimum Spacing From Center of Fan (ft.)	
	A	B
8	12	24
10	15	30
12	18	36
14	21	42

Fan Components

Verify that all of the following parts and hardware have been received prior to beginning installation. Contact your local representative or the manufacturer if replacement parts are required.

NOTE: Additional parts (provided by others) may be required to complete the fan installation, including additional wiring, steel angle or Unistrut® channel, and hardware for connecting the fan mount to the building structure.

NOTE: Hardware quantities listed below indicate what is required to complete installation. Hardware kits may include extra fasteners as a convenience.

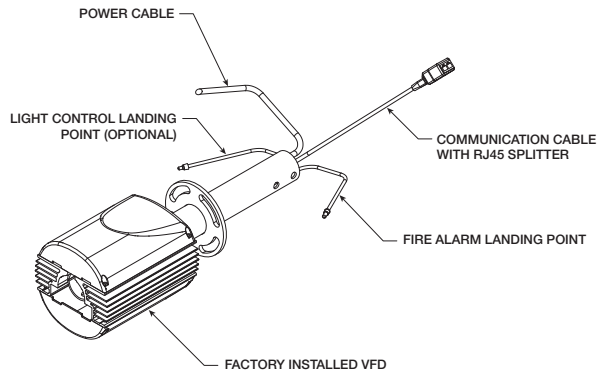

Downtube & Mount Assembly (1)

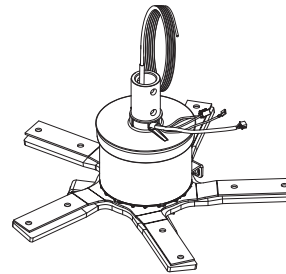

Motor/Hub Assembly (1)

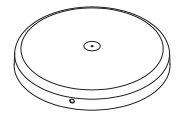

Hub Plate (1)

Bag # 916411		
U-Bolt Steel Cable Clamps (10)	20 Ft. Guy Wire (4)	Guy Wire Clamp Assembly With Clamp Bolt (4)
Quick Link (8)	Turnbuckle (4)	
Motor/Hub and Universal Mounting Bracket Kit Bag # 916399		
3/8 in. – 16 x 2-1/2 in. Grade 8, Hex Bolt (2)		
3/8 in. – 16 Grade 5, Nylon Locknut (2)		
3/8 in. – 16 x 3 in. Grade 5, Hex Bolt (2)		
Airfoil Blade and Hub Plate Hardware Kit Bag # 916400		
5/16 in. – 18 Grade 5, Nylon Locknut (10)		
5/16 in. – 18 x 1-1/4 in. Grade 5, Hex Bolt (10)		
#10 – 12 x 3/4 in. Screw (10)		
1/4 in. – 20 x 1 in. Stainless Steel Machine Screw (3)		

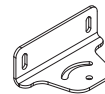

Universal Mounting Bracket (2)



CAT-5e Control Cable (1)



Winglet (5)

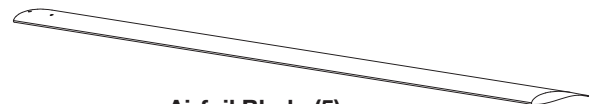

Airfoil Blade (5)

Optional Fan Components

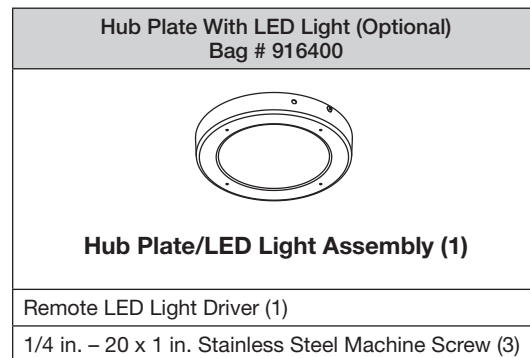
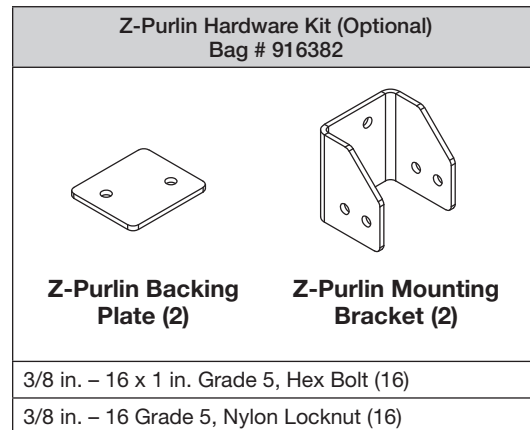
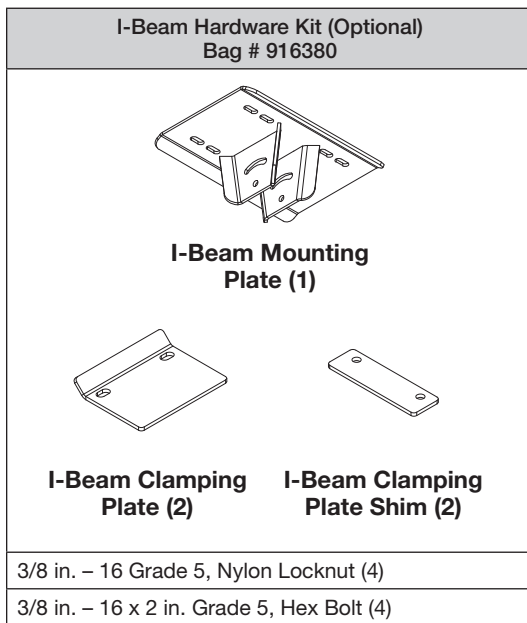
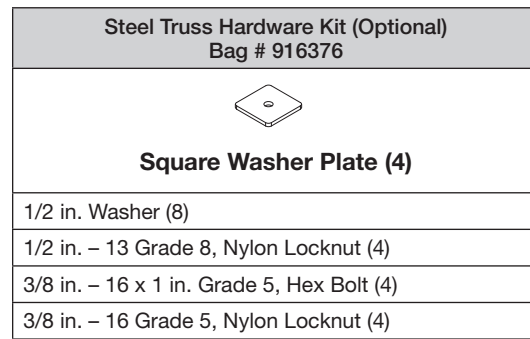
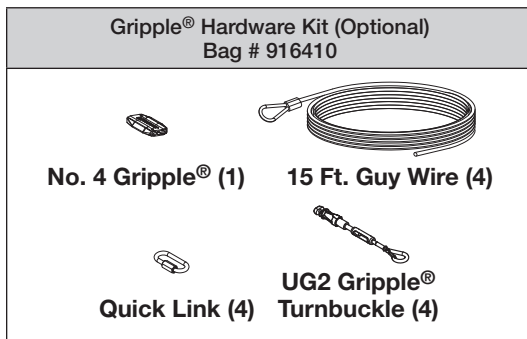

Required Tools

The following tools will be required to complete the installation of every DC fan. Additional tools may be required depending on the application and installation location of the fan.

- Socket Wrench with 7/16 in., 1/2 in., 9/16 in., and 10 mm Sockets
- 7/16 in., 1/2 in., and 9/16 in. Wrenches
- Adjustable Wrench
- Torque Wrench (up to 50 ft-lbf)
- Torque Wrench (up to 120 in-lbf)
- Drill and 7/16 in. Drill Bit
- Phillips Screwdriver
- Level

- Impact Driver
- #2 Phillips Bit and Driver
- Cable Cutters
- Wire Strippers

NOTE: Model DC fan components can weigh 40 lbs or greater depending upon the fan size and accessories that are provided. A suitable means for lifting the weight of the fan to the mounting point, such as a scissor lift, should be used for all DC fan installations.

Mounting Installation

DANGER

Always disconnect, lock and tag power source before installing or servicing. Failure to disconnect power source can result in fire, shock or serious injury.

DANGER

Pour écarter les risques d'incendie, de choc électrique ou de blessure grave, veiller à toujours débrancher, verrouiller et étiqueter la source de courant avant l'installation ou l'entretien.

The following mounting installations are covered in this manual. Identify the supplied mounting kit (page 5-6), locate the appropriate installation within this manual.

- I-Beam Mounting Kit (page 7)
- Steel Truss Mounting Kit (page 7-8)
- Wood Beam Mounting Kit (page 8)
- Z-Purlin Mounting Kit (page 9)
- Unistrut® Mounting Kit (by others, page 9)

I-Beam Mounting Kit (For Flanges up to 7.4 in. Wide)

Components required from Bag # 916380 and 916399:

- I-Beam Mounting Plate (1)
- I-Beam Clamping Plate (2)
- I-Beam Clamping Plate Shim (2)
- 3/8 in. – 16 x 2 in. Grade 5 Hex Bolt (4)
- 3/8 in. – 16 x 3 in. Grade 5 Hex Bolt (2)
- 3/8 in. – 16 Grade 5 Nylon Locknut (6)

Hardware/Tools Needed (Not Included):

- Torque Wrench
 - 9/16 in. Socket and Ratchet
 - 9/16 in. Wrench
1. Attach I-beam mounting plate to the downtube assembly using supplied (2) 3/8 in. – 16 x 3 in. grade 5 hex bolts and (2) 3/8 in. – 16 grade 5 nylon locknuts. Hand tighten hardware until the I-beam mounting plate is securely attached to the downtube but can still be pivoted from side to side (approximately 1/4 in. of the bolt threads exposed below the nylon locknuts).
 2. Using appropriate lifting equipment, raise the downtube and mount assembly until the I-beam mounting plate is positioned on the bottom of the I-beam.
 3. Using the I-beam mounting plate as a guide, identify the appropriate set of mounting slots to use for installation. The I-beam mounting plate can accommodate I-beams with a flange width up to 7.4 in. and a web thickness up to 3/4 in.

4. Attach (1) I-beam clamping plate shim and (1) I-beam clamping plate to the I-beam mounting plate using (2) 3/8 in. – 16 x 2 in. grade 5 hex bolts, and (2) 3/8 in. – 16 grade 5 nylon locknuts. Hook the I-beam clamping plate onto one side of the I-beam and tighten hardware until the I-beam mounting plate is snug against the beam but can still be moved (approximately 1/4 in. of the bolt threads exposed beyond the nylon locknut).

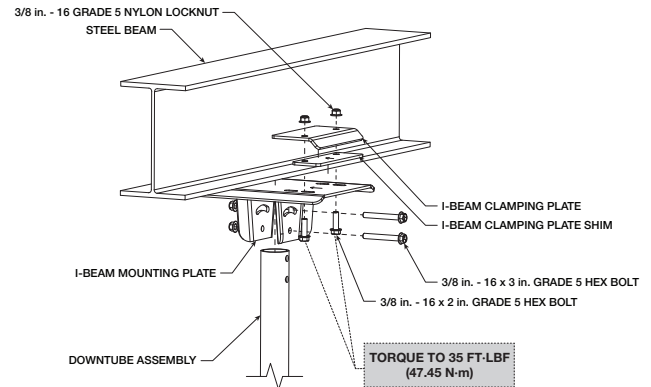

5. Attach the opposing I-beam clamp plate shim and I-beam clamp plate on to the I-beam mounting plate and I-beam. Hand tighten hardware.
6. Center the I-beam mounting plate under the I-beam. Ensure the I-beam clamp plates have maximum engagement on both sides and tighten hardware evenly to 35 ft·lbf (47.45 N·m).
7. Turn to page 10 to continue with Motor/Hub to Downtube Installation.

Steel Truss Mounting Kit

Components required from Bag # 916399 and 916376:

- Universal Mounting Bracket (2)
- Square Washer Plate (4)
- 3/8 in. – 16 x 3 in. Grade 5 Hex Bolt (2)
- 3/8 in. – 16 x 1 in. Grade 5 Hex Bolt (4)
- 3/8 in. – 16 Grade 5 Nylon Locknut (6)
- 1/2 in. – 13 Grade 8 Nylon Locknut (4)

Hardware/Tools Needed (Not Included):

- Structural Steel Angles (2)
- 1/2 in. – 13 Grade 8 Hex Bolt (4), *length determined by truss and steel angle material thickness*
- Torque Wrench
- 9/16 in. Socket and Wrench
- 9/16 in. Wrench
- Drill and 7/16 in. Drill Bit

1. Size structural steel angles (by others) to fit within steel trusses/bar joists. Size of angle to be determined by structural engineer.

2. Mount structural steel angles to steel trusses/bar joists using (4) 1/2 in. – 13, grade 8 hex bolts (by others to accommodate varying material thickness), and supplied (4) square washer plates, and (4) 1/2 in. – 13 nylon locknuts. Note that the hardware should be installed through the gap in the bottom chord of the steel trusses/bar joists (see drawing below). Torque hardware to 35 ft-lbf (47.45 N-m).

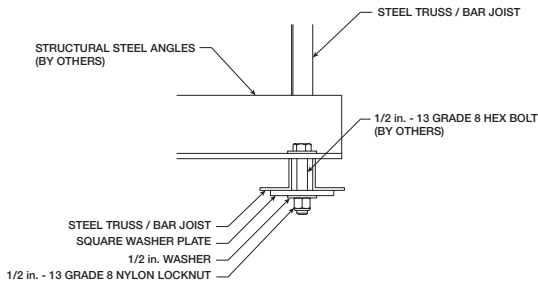
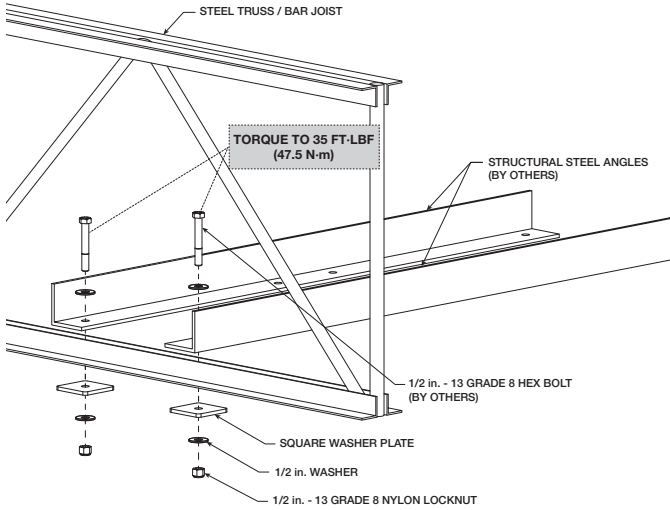

3. Attach universal mounting brackets to the downtube assembly using supplied (2) 3/8 in. – 16 x 3 in. grade 5 hex bolts and (2) 3/8 in. – 16 grade 5 nylon locknuts. Hand tighten hardware until the universal mounting brackets are securely attached to the downtube but can still be pivoted from side to side (approximately 1/4 in. of the bolt threads exposed below the nylon locknuts).

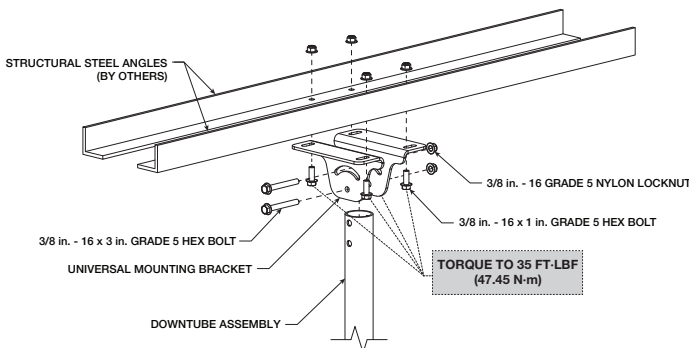

4. Locate desired fan hanging location. Using the universal mounting brackets as a template, mark and drill (4) 7/16 in. holes in structural steel angles.
5. Bolt universal mounting brackets into place using supplied (4) 3/8 in. – 16 x 1 in. grade 5 hex bolts,

and (4) 3/8 in. – 16 grade 5 nylon locknuts. Torque to 35 ft-lbf (47.45 N-m).

6. Turn to page 10 to continue with Motor/Hub to Downtube Installation.

Wood Beam Mounting Kit (For Beams 6 in. Wide or Greater)

Components required from Bag # 916399:

- Universal Mounting Bracket (2)
- 3/8 in. – 16 x 3 in. Grade 5 Hex Bolt (2)
- 3/8 in. – 16 Grade 5 Nylon Locknut (2)

Hardware/Tools Needed (Not Included):

- Wood Beam Fasteners (Max Width Diameter 3/8 in.), Specified By Others
- Torque Wrench
- 9/16 in. Socket and Wrench
- 9/16 in. Wrench
- Drill and Appropriate Drill Bit

1. Attach universal mounting brackets to the downtube assembly using supplied (2) 3/8 in. – 16 x 3 in. grade 5 hex bolts and (2) 3/8 in. – 16 grade 5 nylon locknuts. Hand tighten hardware until the universal mounting brackets are securely attached to the downtube but can still be pivoted from side to side (approximately 1/4 in. of the bolt threads exposed beyond the nylon locknuts).
2. Locate desired fan hanging location. Using the supplied universal mounting brackets as a template, mark and drill (4) holes in the wood beam. Note that the universal mounting brackets can accommodate beam widths 6 in. or greater.
3. Attach universal mounting brackets to wood beam using appropriate wood beam fasteners (by others to accommodate varying material properties). Wood beam fasteners to be specified by structural engineer.

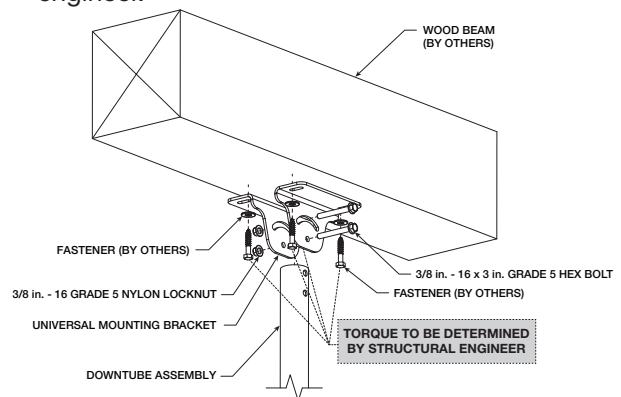

4. Torque wood beam fasteners to value determined by structural engineer.
5. Turn to page 10 to continue with Motor/Hub to Downtube Installation

Z-Purlin Mounting Kit

Components required from Bag # 916399 and 916382:

- Universal Mounting Bracket (2)
- Z-Purlin Backing Plate (2)
- Z-Purlin Mounting Bracket (2)
- 3/8 in. – 16 x 3 in. Grade 5 Hex Bolt (2)
- 3/8 in. – 16 x 1 in. Grade 5 Hex Bolt (16)
- 3/8 in. – 16 Grade 5 Nylon Locknut (18)

Hardware/Tools Needed (Not Included):

- Structural Steel Angles (2)
- Torque Wrench
- 9/16 in. Socket and Wrench
- 9/16 in. Wrench
- Drill and 7/16 in. Drill Bit

1. Locate desired fan hanging location. Using the supplied z-purlin mounting brackets as templates, mark and drill (2) 7/16 in. holes in each z-purlin.
2. Mount z-purlin mounting brackets and backing plates using supplied (4) 3/8 in. – 16 x 1 in. grade 5 hex bolts, and (4) 3/8 in. – 16 grade 5 nylon locknuts. Torque hardware to 35 ft·lbf (47.45 N·m).

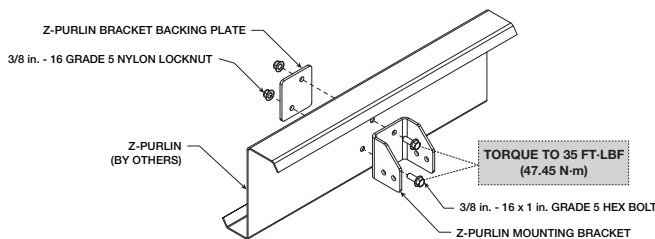

3. Size structural steel angles (by others) to fit within z-purlins and installed z-purlin mounting brackets. Size of angle to be determined by structural engineer.
4. Bolt structural steel angles in place using supplied (8) 3/8 in. – 16 x 1 in. grade 5 hex bolts, and (8) 3/8 in. – 16 grade 5 nylon locknuts. Torque hardware to 35 ft·lbf (47.45 N·m).

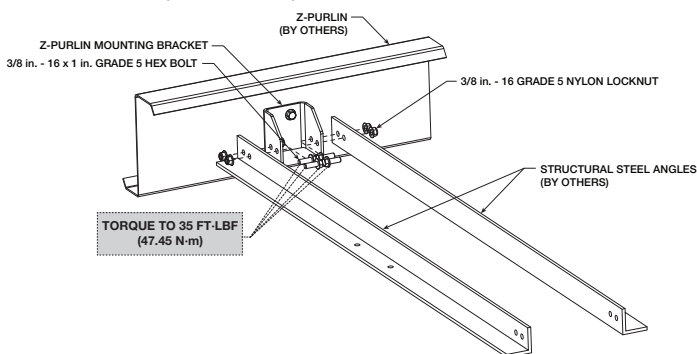

5. Attach universal mounting brackets to the downtube assembly using supplied (2) 3/8 in. – 16 x 3 in. grade 5 hex bolts and (2) 3/8 in. – 16 grade 5 nylon locknuts. Hand tighten hardware until the universal mounting brackets are securely attached

to the downtube but can still be pivoted from side to side (approximately 1/4 in. of the bolt threads exposed beyond the nylon locknuts).

6. Using the universal mounting brackets as a template, mark and drill (4) 7/16 in. holes in structural steel angles.
7. Align the universal mounting brackets and bolt into place using (4) 3/8 in. – 16 x 1 in. grade 5 hex bolts, and (4) 3/8 in. – 16 grade 5 nylon locknuts. Torque hardware to 35 ft·lbf (47.45 N·m).

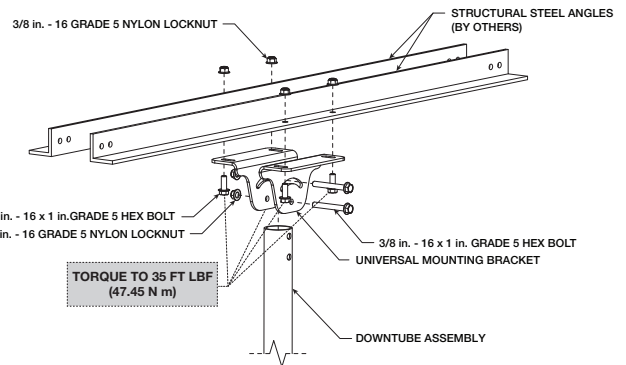

8. Turn to page 10 to continue with Motor/Hub to Downtube Installation.

Unistrut® Mounting Kit (By Others)

Components required from Bag # 916399:

- Universal Mounting Bracket (2)
- 3/8 in. – 16 x 3 in. Grade 5 Hex Bolt (2)
- 3/8 in. – 16 Grade 5 Nylon Locknut (2)

Hardware/Tools Needed (Not Included):

- Unistrut® Channels
- Unistrut and Fan Installation Hardware

1. Size Unistrut channels (by others) to span the required distance between structural members of the building. Size of Unistrut channels and appropriate installation hardware to be determined by structural engineer. Contact Unistrut customer support (www.unistrut.us) for product recommendations and detailed installation instructions for Unistrut products.
2. Install Unistrut channels per the manufacturer's recommendations.
3. Locate desired hanging location for the fan.
4. Attach universal mounting brackets to the downtube assembly using supplied (2) 3/8 in. – 16 x 3 in. grade 5 hex bolts and (2) 3/8 in. – 16 grade 5 nylon locknuts. Hand tighten hardware until the universal mounting brackets are securely attached to the downtube but can still be pivoted from side to side (approximately 1/4 in. of the bolt threads exposed beyond the nylon locknuts).
5. Bolt universal mounting brackets to Unistrut channels with the appropriate hardware as identified by structural engineer. Torque to 35 ft·lbf (47.45 N·m).

Motor/Hub to Downtube Installation

Components required from Bag # 916399:

- Motor/Hub Assembly (1)
- 3/8 in. – 16 x 2-1/2 in. Grade 8 Hex Bolt (2)

Hardware/Tools Needed (Not Included):

- 9/16 in. Socket
- Socket Wrench
- Torque Wrench
- Phillips Screwdriver
- Lifting Equipment
- Level
- Cribbing (optional)
- Awl (optional)

DANGER
Always disconnect, lock and tag power source before installing or servicing. Failure to disconnect power source can result in fire, shock or serious injury.
DANGER
Pour écarter les risques d'incendie, de choc électrique ou de blessure grave, veiller à toujours débrancher, verrouiller et étiqueter la source de courant avant l'installation ou l'entretien.

1. Using a scissor lift or other suitable lifting device, lift the motor/hub assembly by resting the motor struts on the lift structure or cribbing.
2. Feed the safety retention cable that is attached to the motor/hub assembly up through the bottom of the downtube until the loose end of the safety cable is accessible at the top of the downtube. Pull the loose end of the safety retention cable from the top of the downtube until all of the slack is pulled through.
3. Using a Phillips screwdriver, remove the front and back VFD covers and set aside.
4. Carefully align the motor axle with the downtube opening, making sure that the wires protruding from the motor axle are on the same side as the exposed circuit board of the VFD.

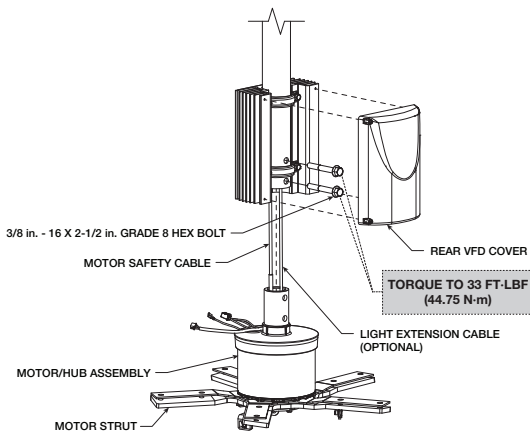

5. Slowly lift the motor/hub assembly until the motor axle is nested inside the downtube. Take care to align the motor axle holes with the downtube holes.

IMPORTANT: Do not allow safety cable or wiring to be crushed while lifting the motor/hub assembly into the downtube. Safety cable must be kept taut inside the downtube in order to prevent damage. If either the safety cable or the wiring are damaged during installation, contact your local rep or the manufacturer.

6. Install the supplied (2) 3/8 in. – 16 x 2-1/2 in. grade 8 hex bolts into the locknuts attached to the downtube. Torque the bolts to a value of 33 ft-lbf (44.75 N·m).

NOTE: When leveling the fan, the level should be moved around the circumference of the downtube periodically to ensure that the fan is level.

7. Place a level against the downtube and adjust the angle of the downtube until the fan is level. Tighten the hardware connecting the downtube to the mount and torque to 25 ft-lbf (33.90 N·m).

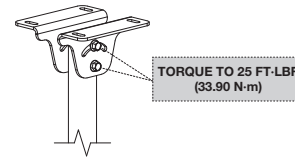

8. Plug in the motor power, ground, and hall connection wires as shown below. Note that the connectors on the hall connection and motor power wires only fit in one specific orientation.

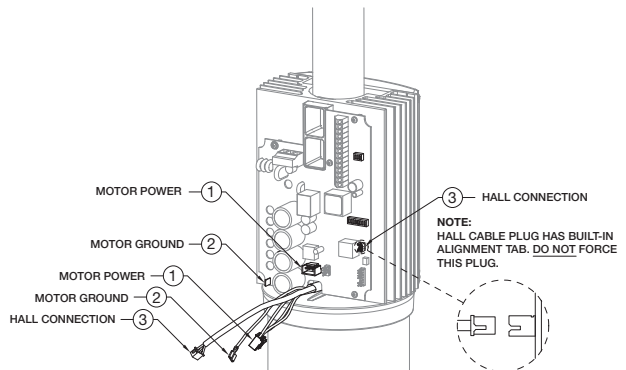

Fan Networking

If networking multiple fans to run using a single control source, the dipswitch settings on each fan's VFD circuit board will need to be adjusted using the following instructions.

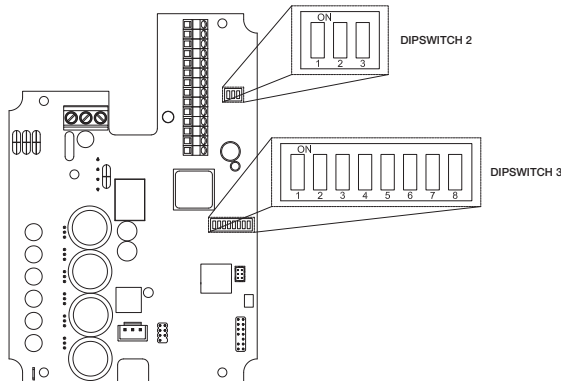

First Fan

- Determine the first fan in the network daisy-chain by identifying the fan that is connected directly to the control source.
- Remove the front VFD cover from the first fan in the network using a phillips screwdriver.
- Dipswitch 2 is used to set parameters that improve network function. Verify that each of the switches on dipswitch 2 are set as follows:
 - Position 1 – Off
 - Position 2 – On
 - Position 3 – On
- Dipswitch 3 is used to set unique Modbus addresses for each fan in the daisy-chain. Adjust positions 1-5 on dipswitch 3 to set the desired Modbus address. A table with all possible Modbus addresses is shown to the right.

IMPORTANT: Positions 6 – 8 are used to set parameters needed for fan operation and should not be adjusted.

- Refer to instruction manual provided with HVLS control to determine if additional networking modifications are required. Follow instructions to complete necessary modifications.
- Reinstall the front VFD cover.

All Remaining Fans

- Remove the front VFD cover using a phillips screwdriver.
- Set dipswitch 2 as shown below. Dipswitch 2 is used to set parameters that improve network function and will need to be adjusted for all fans in the network except for the first fan.
 - Position 1 – Off
 - Position 2 – Off
 - Position 3 – Off

- Adjust positions 1 – 5 on dipswitch 3 so that each successive fan has a unique Modbus address. A table with all possible Modbus addresses is shown below.

IMPORTANT: Positions 6 – 8 are used to set parameters needed for fan operation and should not be adjusted.

NOTE: It is good practice to use successive Modbus addresses for networked fans, but this is not necessary for proper functioning of the network.

- Refer to instruction manual provided with HVLS control to determine if additional networking modifications are required. Follow instructions to complete necessary modifications.
- Reinstall the front VFD cover.

Modbus Address Settings - Dipswitch 3						
Modbus Address	Position 1	Position 2	Position 3	Position 4	Position 5	Position 6, 7, 8
2	On	Off	Off	Off	Off	Do Not Modify
3	Off	On	Off	Off	Off	
4	On	On	Off	Off	Off	
5	Off	Off	On	Off	Off	
6	On	Off	On	Off	Off	
7	Off	On	On	Off	Off	
8	On	On	On	Off	Off	
9	Off	Off	Off	On	Off	
10	On	Off	Off	On	Off	
11	Off	On	Off	On	Off	
12	On	On	Off	On	Off	
13	Off	Off	On	On	Off	
14	On	Off	On	On	Off	
15	Off	On	On	On	Off	
16	On	On	On	On	Off	
17	Off	Off	Off	Off	On	
18	On	Off	Off	Off	On	
19	Off	On	Off	Off	On	
20	On	On	Off	Off	On	
21	Off	Off	On	Off	On	
22	On	Off	On	Off	On	
23	Off	On	On	Off	On	
24	On	On	On	Off	On	
25	Off	Off	Off	On	On	
26	On	Off	Off	On	On	
27	Off	On	Off	On	On	
28	On	On	Off	On	On	
29	Off	Off	On	On	On	

Safety Retention Cable Installation

IMPORTANT: Do not put excessive tension on the safety retention cable during installation. The safety retention cable should be installed with a small amount of slack in the cable to ensure proper functioning. Do not allow the safety retention cable to come in contact with any sharp edges.

NOTE: Failure to install the safety retention cable will void the fan warranty.

Standard Steel Cable Clamp

The following instructions apply to standard fan installations. For fans that were supplied with optional Gripple® hardware, refer to the instructions on page 12-13.

Components required from Bag # 916411:

- 0.188 in. U-Bolt Steel Cable Clamp (2)

Hardware/Tools Needed (Not Included):

- Torque Wrench
- 7/16 in. Socket and Wrench
- Cable Cutters (optional)

1. From the top of the downtube, pull the safety retention cable until it is taut inside the downtube.
2. Wrap the loose end of the safety cable around the mounting structure. Do not allow the cable to come in contact with any sharp edges.
3. Align the loose end of the safety cable (referred to as the dead-end) with the length of cable that is wrapped around the mounting structure (referred to as the live-end).
4. Attach the dead-end of the safety cable to the live-end using the supplied 0.188 in. U-bolt steel cable clamps. Loosely tighten the nuts on the steel cable clamps, leaving enough room for the safety cable to slide through the steel cable clamps.

IMPORTANT: The first steel cable clamp must be installed a minimum of 5-1/2 in. away from the dead-end of the safety cable to ensure proper functioning.

IMPORTANT: Steel cable clamps are composed of two parts: the U-bolt and the saddle. Steel cable clamps must be installed with the U-bolt over the dead-end of the safety retention cable and the saddle over the live-end of the safety cable. Failure to install steel cable clamps in this manner may result in unsafe operating conditions. Refer to drawings for correct orientation.

5. Pull the dead-end of the safety cable through the steel cable clamps to tighten the cable. The cable should be pulled taut, leaving only a small amount of slack in the cable to ensure proper functioning.
6. Tighten the nuts on the steel cable clamps using a 7/16 in. socket and torque to 54 in·lbf (6.10 N·m), alternating between nuts until reaching proper torque.

7. Cut or organize excess safety cable to ensure it does not interfere with fan performance. Make sure to leave at least 5-1/2 in. of cable between the dead-end of the cable and the first steel cable clamp to ensure proper functioning.

Gripple® Hardware (Optional)

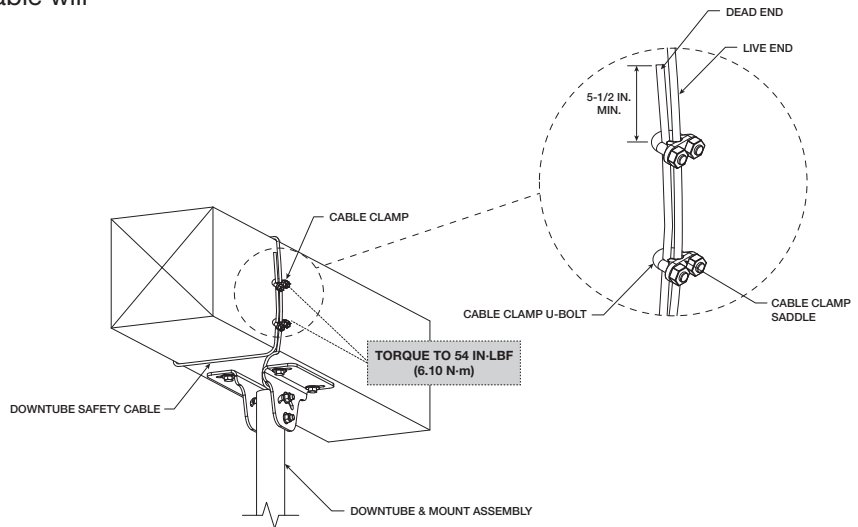

The following instructions apply to fans that were supplied with optional Gripple® hardware. For fans that were supplied with standard steel cable clamp hardware, refer to the instructions on page 12.

Components required from Bag # 916410:

- No. 4 Gripple Connector (1)

Hardware/Tools Needed (Not Included):

- 1/16 in. Allen Wrench (optional)
- Cable Cutters (optional)

1. From the top of the downtube, pull the safety retention cable until the cable is taut inside the downtube.
2. Insert the loose end of the safety cable into the No. 4 Gripple connector. Note that the cable will only feed through the Gripple connector in one direction (marked on the Gripple connector with an arrow).
3. Slide the No. 4 Gripple connector down the safety cable until it is located near the opening at the top of the downtube.
4. Wrap the loose end of the safety cable around the mounting structure. Do not allow the cable to come in contact with any sharp edges.
5. Insert the loose end of the safety cable into the open hole of the No. 4 Gripple connector. Note that the cable will only feed through the Gripple connector in one direction (marked on the Gripple connector with an arrow).
6. Pull the loose end of the safety cable through the Gripple connector to tighten the cable. The cable

should be pulled taut, leaving only a small amount of slack in the cable to ensure proper functioning.

7. Cut or organize excess safety cable to ensure it does not interfere with fan performance.

NOTE: If necessary, the safety cable can be loosened by inserting the long end of a 1/16 in. allen wrench into either of the pin holes on the No. 4 Gripple connector and pulling the cable in the opposite direction of the arrow marked on the Gripple connector.

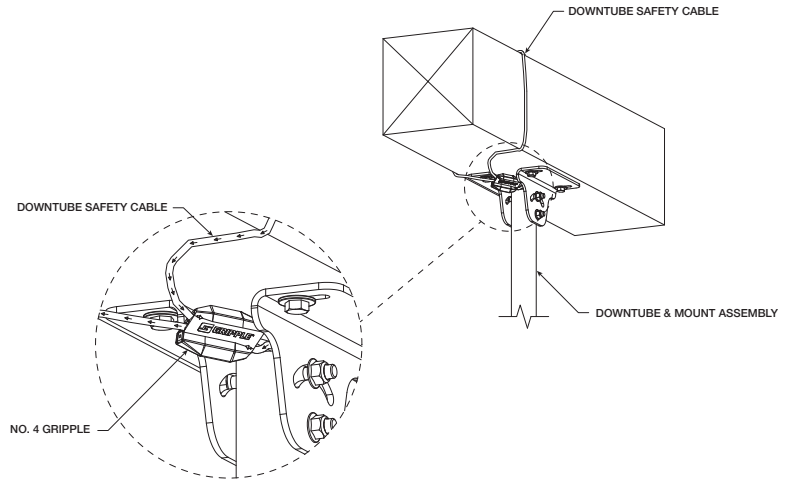

Guy Wire Installation – Drop Lengths 4 ft. and Greater

NOTE: Guy wires are only supplied for fans with drop lengths equal to or greater than 4 feet. Fans with drop lengths up to 3 feet do not require guy wires.

IMPORTANT: Guy wires must be installed for drop lengths equal to or greater than 4 feet. Guy wires must be installed 45° to 60° from vertical to ensure proper functioning.

Standard Steel Cable Clamp

The following instructions apply to standard fan installations. For fans that were supplied with optional Gripple® hardware, refer to the instructions on page 14.

Components required from Bag # 916411:

- Guy Wire Clamp Assembly (4)
- Guy Wire Clamp Bolt (4)
- Quick Link (8)
- 20 ft. Guy Wire (4)
- 0.094 in. U-Bolt Steel Cable Clamp (8)
- Turnbuckle (4)

Hardware/Tools Needed (Not Included):

- Level
- Torque Wrench
- 5/16 in. Socket and Wrench
- Adjustable Wrench
- Cable Cutters (optional)

1. Secure guy wire clamps to the building structure using the guy wire clamp bolts and an adjustable wrench. Attach guy wires to the eyelets on the guy wire clamp assemblies using the supplied quick links.

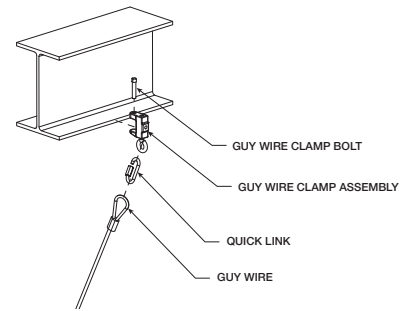

2. Insert the loose end of each guy wire through the eyebolt on a turnbuckle. Turn the guy wire back onto itself and align the loose end of the guy wire (referred to as the dead-end) with the length of guy wire that is attached to the building structure (referred to as the live-end).
3. Attach the dead-end of each guy wire to the live-end using (2) of the supplied 0.094 in. U-bolt steel cable clamps. Loosely tighten the nuts on the steel cable clamps, leaving enough room for the guy wire to slide through the steel cable clamps.

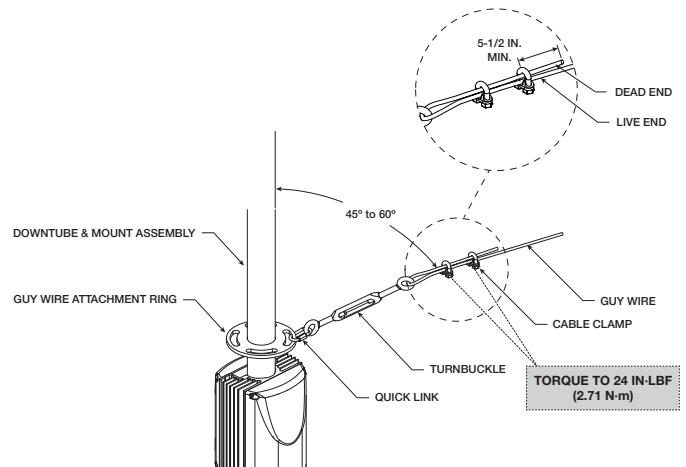

IMPORTANT: The first steel cable clamp must be installed a minimum of 5-1/2 in. away from the dead-end of the guy wire to ensure proper functioning.

IMPORTANT: Steel cable clamps are composed of two parts: the U-bolt and the saddle. Steel cable clamps must be installed with the U-bolt over the dead-end of the guy wire and the saddle over the live-end of the guy wire. Failure to install steel cable clamps in this manner may result in unsafe operating conditions. Refer to drawings below for correct orientation.

4. Attach all (4) turnbuckles to the guy wire attachment ring located on the downtube using (4) supplied quick links.
5. Pull the dead-end of each guy wire through the steel cable clamps until taut.
6. Tighten the nuts on the steel cable clamps using a 5/16 in. socket and torque to 24 in·lbf (2.71 N·m), alternating between nuts until reaching proper torque.
7. Place a level against the downtube and tighten all (4) turnbuckles by hand in a crisscross pattern until the guy wires are tight and the fan is level.

NOTE: When leveling the fan, place the level against the downtube in-between two neighboring guy wires to simplify the leveling process. The level should also be moved around the circumference of the downtube periodically to ensure that the fan is level in all directions.

8. Cut or organize excess guy wires to ensure that they do not interfere with fan performance. Make sure to leave at least 5-1/2 in. of wire between the dead-end of the guy wire and the first wire rope clip to ensure proper functioning.

Gripple® Hardware (Optional)

The following instructions apply to fans that were supplied with optional Gripple® hardware. For fans that were supplied with standard steel cable clamp hardware, refer to the instructions on page 13.

Components required from Bag # 916410:

- Guy Wire Clamp Assembly (4)
- Guy Wire Clamp Bolt (4)
- Quick Link (4)
- 15 ft. Guy Wire (4)
- UG2 Gripple With Turnbuckle (4)

Hardware/Tools Needed (Not Included):

- Level
- Adjustable Wrench
- Cable Cutters (optional)

1. Secure guy wire clamps to the building structure using the guy wire clamp bolts. Attach guy wires to the eyelets on the guy wire clamp assemblies using the supplied quick links.

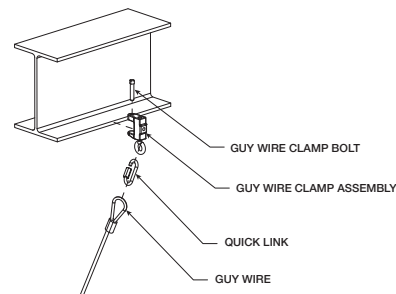

2. Insert the loose end of each guy wire into the base of UG2 Gripple® turnbuckle until a length of wire is pushed through the side of the turnbuckle.
3. Clip all (4) UG2 Gripple® turnbuckles to the guy wire attachment ring located on the downtube. Pull the loose end of each guy wire through the turnbuckles until each guy wire is taut.

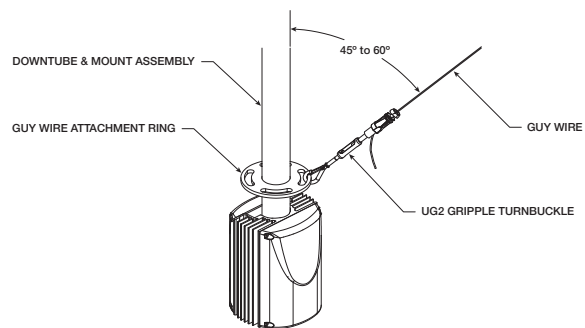

4. Place a level against the downtube and tighten all (4) turnbuckles by hand in a crisscross pattern until the guy wires are tight and the fan is level.

NOTE: When leveling the fan, place the level against the downtube in-between two neighboring guy wires to simplify the leveling process. The level should also be moved around the circumference of the downtube periodically to ensure that the fan is level in all directions.

5. Tighten the set screw on each turnbuckle by twisting the plastic knob at the base of the turnbuckle.
6. Cut or organize excess guy wires to ensure that they do not interfere with fan performance.

NOTE: If necessary, the guy wires can be loosened by twisting the plastic knob at the base of the turnbuckle until it is loose enough to push the knob inwards and compress the spring-loaded plunger, allowing the cable to slide through the turnbuckle.

Airfoil Blade & Winglet Installation

IMPORTANT: Do not operate fans without the airfoil blades. Failure to comply with this warning will result in voiding of the product warranty and may result in permanent damage to the VFD and motor.

WARNING

To reduce the risk of personal injury, do not bend motor struts, airfoil blades, or airfoil retaining links when installing the airfoil blades, balancing the blades, or cleaning the fan. Damage to these components may result in unsafe operation of the fan, which can lead to property damage, personal injury or death. Contact your local representative or the factory if replacement parts are needed.

WARNING

To reduce the risk of personal injury, do not insert foreign objects in between rotating fan blades.

AVERTISSEMENT

Pour réduire le risque de blessure, ne pliez pas les entretoises moteurs, ailerons ou aile en conservant des liens lors de l'installation des aubes, équilibrez, ou nettoyer le ventilateur. Ces composants peuvent endommager en utilisation dangereuse du ventilateur, qui peut conduire à des dommages matériels, des blessures ou la mort. Ces composants peuvent endommager en utilisation dangereuse du ventilateur, qui peut conduire à des dommages matériels, des blessures ou la mort.

AVERTISSEMENT

Ces composants peuvent endommager en utilisation dangereuse du ventilateur, qui peut conduire à des dommages matériels, des blessures ou la mort.

Components required from Bag # 916400:

- Airfoil Blade (5)
- Winglet (5)
- #10 – 12 x 3/4 in. Screw (10)
- 5/16 in. – 18 Grade 5 Nylon Locknut (10)
- 5/16 in. – 18 x 1-1/4 in. Grade 5 Hex Bolt (10)

Hardware/Tools Needed (Not Included):

- 1/2 in. Socket and Socket Wrench
- 1/2 in. Wrench
- Torque Wrench
- #2 Phillips Bit and Driver

1. Install one winglet per airfoil blade using the screw bosses located in each blade on the opposite end from the mounting holes. Use a #2 phillips bit to install (2) #10 – 12 x 3/4 in. screws per winglet. Torque screws to 60 in·lbf (6.8 N·m).

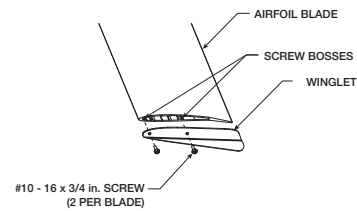

2. Lift the first blade into place, and slide over the motor strut allowing the airfoil retaining ring to rest on top of the airfoil blade. It might be necessary to use two people for this step.
3. With the blade in position on the motor strut, install (2) 5/16 in. - 18 x 1-1/4 in. hex bolts, and (2) 5/16 in. – 18 nylon locknuts as shown below. Hand tighten hardware.

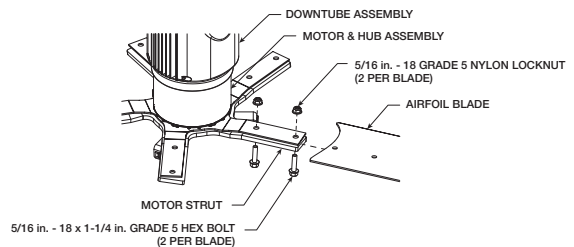

4. Repeat steps 1 through 3 on remaining airfoil blades. Torque the (10) installed bolts to 20 ft·lbf (27.12 N·m).

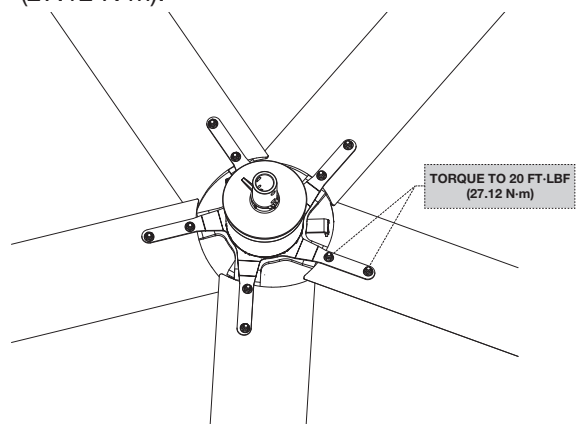

IMPORTANT: If airfoils must be removed and reinstalled for any reason, do not re-use the supplied nylon locknuts. Re-use increases the risk of locknuts loosening during operation, which may result in unwanted noise and/or unsafe operation of the fan. Contact your local representative or the factory if replacement parts are needed.

Hub Plate Installation

Components required from Bag # 916400:

- Hub Plate (1)
- 1/4 in. – 20 x 1 in. Stainless Steel Machine Screw (3)

Hardware/Tools Needed (Not Included):

- Phillips Screwdriver

1. Align (3) holes in the hub plate with the (3) U-nuts on the hub retention bracket.
2. Insert (1) 1/4-20 x 1 in. stainless steel machine screw per hole and hand tighten to ensure all fasteners will engage the U-nuts.
3. Hand tighten fasteners using a phillips screwdriver.

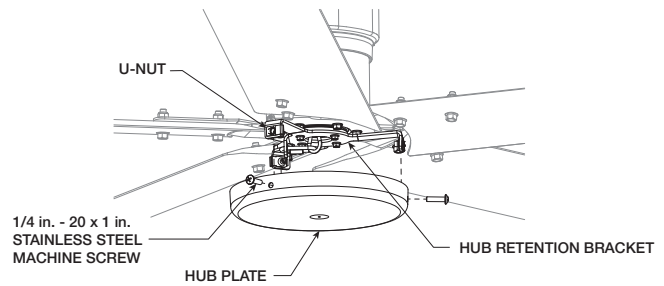

Hub Plate With LED Light Installation (Optional)

Components required from Bag # 916400:

- Hub Plate/LED Light Assembly (1)
- Remote LED Light Driver (1)
- 1/4 in. – 20 x 1 in. Stainless Steel Machine Screw (3)

Hardware/Tools Needed (Not Included):

- #2 Phillips Screwdriver
- Wire Cutter
- Wire Stripper

1. Mount the LED light driver box in close proximity to the mounting plate of the fan.
2. Open the cover of the LED light driver box and remove knockouts needed on the box.
3. Locate the power supply leads from LED light driver box and connect to building power supply.
4. Locate pre-wired control lead extending from fan downtube labeled “Light Relay”.

NOTE: Red is 0-10V and Black is common.

5. Locate the purple wire from the LED light driver box and attach to the red wire of the pre-wired control lead.
6. Locate the grey wire from the LED light driver box and attach to the black wire of the pre-wired control lead.
7. Place all wiring and connections back inside the LED light driver box and close the cover.
8. Select the desired LED color temperature using the color temperature adjustment switch on the exterior of the LED light driver box.

9. Attach the female end of the LED light driver box to the male end of the electrical jumper cable (extending from the top of the downtube). The arrow on the male and female parts of the connector between the fixture and jumper should line up.

NOTE: Electrical jumper cable must be fed up through downtube during motor installation.

10. On the hub plate/LED light assembly, attach the male end from the light to the female end of the electrical jumper cable (extending from the bottom of the motor). The arrow on the male and female parts of the connector between the fixture and jumper should line up.
11. Raise the hub plate/LED light assembly until the (3) holes in the plate are aligned with the (3) U-nuts on the hub retention bracket.
12. Install (1) 1/4 in. – 20 x 1 in. stainless steel machine screw per hole. Hand tighten to ensure all fasteners engage with the U-nuts.
13. Tighten all fasteners using a #2 Phillips screwdriver.
14. Gently turn fan to verify airfoils do not contact screw heads.

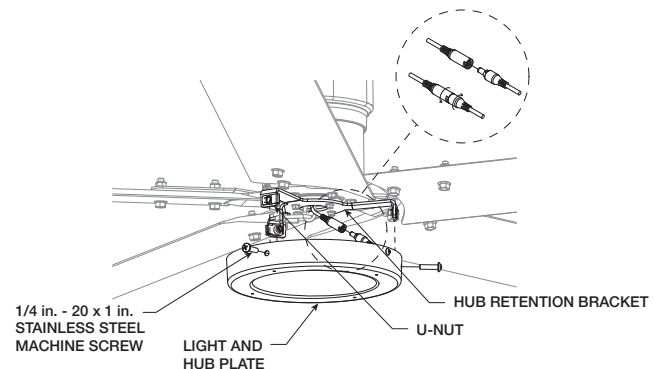

Wiring and Electrical – Factory Wiring Installation

The following instructions apply to fans that were supplied with plug-and-play factory wiring.

Fire Alarm Relay Installation

DANGER

Always disconnect, lock and tag power source before installing or servicing. Failure to disconnect power source can result in fire, shock or serious injury.

DANGER

Pour écarter les risques d'incendie, de choc électrique ou de blessure grave, veiller à toujours débrancher, verrouiller et étiqueter la source de courant avant l'installation ou l'entretien.

NOTE: The following instructions are only applicable to buildings that are equipped with a fire suppression system. If the building does not contain a fire suppression system, leave the crimp connector on the fire alarm landing point (located at the top of the downtube) and continue with the rest of the installation.

Included Component:

- Low Voltage (24VDC/VAC or 115VAC), Normally Closed Relay (1)

Hardware/Tools Needed (Not Included):

- Standard Screwdriver
- Cable Cutters
- Wire Strippers

1. If the building is equipped with a fire suppression system, remove the crimp connector from the fire alarm emergency stop landing point located at the top of the downtube by snipping the wires directly below the crimp connector.
2. Strip the loose wires and wire the supplied normally-closed relay to the fire alarm emergency stop landing point and the building's fire suppression system using the wiring diagram shown.

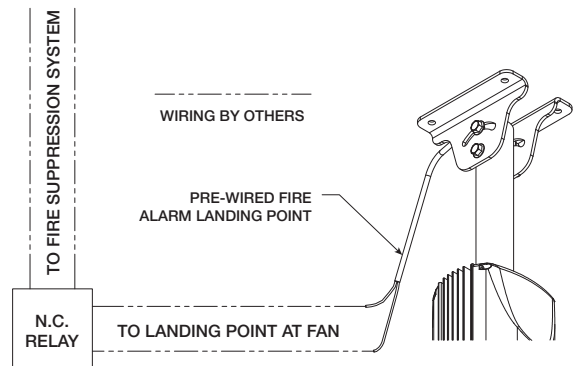

Communication Wiring & Fan Control Installation



IMPORTANT: DC fans must be installed with the supplied CAT-5e communication cable or shielded CAT-5e (by others) that complies with the following specifications. Cable must be twisted pair, shielded 26 ga. CAT-5e cable with a drain wire and must be compliant with ISO 11801. Cable must use shielded RJ45 connectors with a soldered drain and wiring configuration must follow EIA/TIA T568B wiring pinout. Individual CAT-5e cable lengths must not exceed 200 ft. in order to prevent network communication issues.

With Pre-Built CAT-5e Cable

Included Component:

- 100 – 200 ft. CAT-5e Control Cable (1)

Hardware/Tools Needed (Not Included):

- Fan Control (1, optional)

1. Plug one end of the CAT-5e control cable into the 2-way RJ45 splitter located at the top of the downtube. The cable can be plugged into any open receptacle on the splitter.
2. Identify the desired location for installation of the fan control and run the remainder of the CAT-5e control cable to this location.
3. Secure the CAT-5e control cable to the building structure to ensure it does not interfere with fan performance. To prevent communication issues, do not coil excess control cable or route control cable with power wiring.
4. If provided, mount the optional fan control in the desired location and plug the CAT-5e cable into the RJ45 port on the control. Otherwise, install and wire the control source according to the manufacturer's instructions.
5. If one control source will be used to operate multiple fans, the fans can be daisy-chained together to create a network using the following instructions.

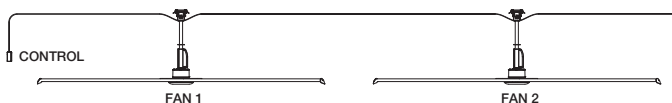

- a. Wire the first fan in the chain to the control source using steps 1-4 above.
- b. Plug an additional CAT-5e control cable into the 2-way RJ45 splitter located at the top of the downtube on the first fan. Connect the other end of this CAT-5e cable into the 2-way splitter on the next fan.

- c. Repeat step 5b. for subsequent fans until all fans in the chain are connected in series.
- d. Follow the “Fan Networking” instructions on page 11 to complete network setup for the fans.

With Optional 1,000 ft. Bulk Spool of CAT-5e Cable

Included Component:

- 1,000 ft. Bulk Spool of CAT-5e Control Cable (1)
- Shielded, Pass-Through RJ45 Connectors (25)

Hardware/Tools Needed (Not Included):

- Fan Control (1, optional)
- CAT-5e Termination Tool

1. Determine required length of CAT-5e cable run. Unspool appropriate amount of cable and cut to length.

IMPORTANT: Individual CAT-5e cable lengths must not exceed 200 ft. in order to prevent network communication issues.

2. Strip and remove 2 in. of CAT-5e cable jacket leaving the foil shield intact.
3. Fold foil shield back over cable jacket and trim foil so that 1/4 in. remains.
4. Untwist conductor pairs, straighten and align wires according to EIA/TIA T568B wiring pinout.

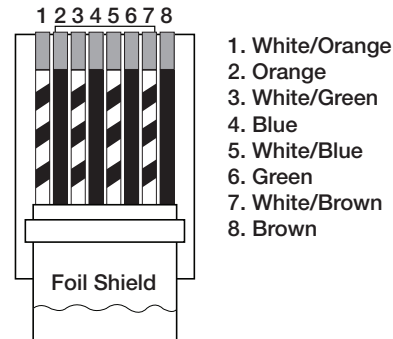

5. Trim conductor ends flush leaving 1 in. exposed.
6. Fully insert cable into shielded, pass-through RJ45 connectors until foil enters back end of connector. Use only the provided RJ45 connectors.
7. Verify that conductors are in the correct wiring scheme order.
8. Crimp RJ45 connector with CAT-5e termination tool (not included).
9. Repeat on opposite end of CAT-5e cable to complete cable construction.
10. Follow the “With Pre-Built CAT-5e Cable” instructions on page 18 to complete communication wiring and fan control installation.

Power Wiring Installation

DANGER

Always disconnect, lock and tag power source before installing or servicing. Failure to disconnect power source can result in fire, shock or serious injury.

DANGER

Pour écarter les risques d'incendie, de choc électrique ou de blessure grave, veiller à toujours débrancher, verrouiller et étiqueter la source de courant avant l'installation ou l'entretien.

IMPORTANT: Do not connect power until mechanical installation, fire alarm relay installation, communication wiring and fan control installation are complete.

IMPORTANT: Do not apply power to the fan above the rated voltage of the variable frequency drive (VFD). Failure to comply with this warning will result in voiding of the product warranty and may result in permanent damage to the VFD and motor.

IMPORTANT: To prevent electrical failures, source power must comply with the following power quality requirements. If source power falls outside of these specified tolerances, an external power line filter will be required (by others). If other power quality issues are present, contact the factory for support.

Allowable Voltage Fluctuation	+/- 10% of nominal
Allowable Frequency Fluctuation	+/- 5% of nominal (47-63 Hz)
Area of Use	Do not install fans in electrical environments with Pollution higher than Degree 2 in accordance with UL 61800-5-1
Surge Immunity	Do not install fans in electrical environments above Installation Class 3 in accordance with IEC 61000-4-5

Hardware/Tools Needed:

- Phillips Screwdriver

With Optional Electrical Plug

1. If the fan is supplied with the optional electrical plug for power wiring, refer to the chart for the corresponding receptacle that will be needed (provided by others).

Electrical Plug Reference			
Voltage	Phase	Plug*	Receptacle
115	1	5-15P	5-15R
208-230	1	L6-30P	L6-30R

*NOTE: Plugs are available from manufacturer. Receptacles must be provided by others.

2. Install the receptacle according to all national and local codes for electrical wiring.
3. Insert the electrical plug into the receptacle and twist to lock the plug in place.
4. Secure any loose power cable to the building structure to ensure it does not interfere with fan performance.

Without Optional Electrical Plug

1. If the fan is not supplied with the optional electrical plug, refer to the wiring diagram below to complete power wiring.
2. Secure any loose power cable to the building structure to ensure it does not interfere with fan performance.

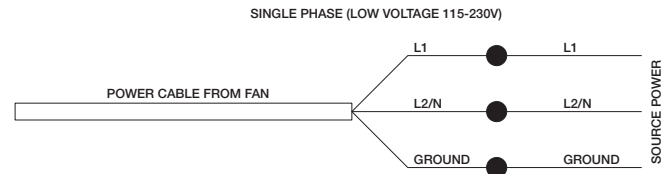

Disconnect and Fuse Installation

1. If provided, mount and wire the optional safety disconnect switch outside of the sweep of the fan's airfoil blades. Installation should be completed per the disconnect manufacturer's recommendation. Be sure to follow all national and local codes for electrical installation.
2. If fusing is required, refer to the fuse sizing charts included below. If the fan was supplied with the optional fused disconnect, the fuses received will match the models shown below. Install fuses per the manufacturer's recommendation. Be sure to follow all national and local codes for electrical installation.

Fuse Sizing Chart		
DC-5 (8 to 14 ft.) 175W Motor		
Motor Voltage	115V/ 1 PH/60 HZ	208-230V/ 1 PH/60 HZ
Motor Full Load Amps (FLA)*	5A	5A
Fuse Required**	FRN-R-6	FRN-R-6
*FLA is based on worst case system conditions assuming lowest nominal voltage and phase.		
** Fuses shown are available as an optional accessory. Fuses provided by others must meet requirements of all national and local codes.		

Pre-Start-Up Checks

1. Disconnect and lock-out all power switches to fan.
2. Check all fasteners and set screws on the ceiling mount, mounting kit, impeller, VFD, motor and accessories for tightness.
3. Rotate the fan impeller by hand to ensure that it rotates freely and does not come into contact with any obstructions.
4. Check all electrical connections for proper attachment.
5. Verify that the fan is hanging so that the airfoils and downtube are level and the fan is plumb to the floor. Adjust guy wire tension as necessary (if applicable).

Operation

IMPORTANT: If unusual vibration or oscillating movement is observed during fan operation, immediately discontinue use of the fan and contact the manufacturer or a suitably qualified maintenance/repair technician.

1. When the fan is started, observe the operation and check for any unusual noise, vibration or overheating. Refer to the Troubleshooting section of this manual if a problem develops.
2. With the system in full operation, measure current input to the VFD and compare with the FLA ratings in the tables above to determine if the motor/VFD system is operating under safe load conditions.
3. Keep approaches to fan clean and free from obstruction.

Inspection

DANGER

Disconnect and secure to the 'OFF' position all electrical power to the fan prior to inspection or servicing. Failure to comply with this safety precaution could result in serious injury or death.

DANGER

Pour écarter les risques de blessure grave ou de mort, débrancher et verrouiller l'alimentation électrique en position « Arrêt » avant tout contrôle ou entretien.

Inspection of the fan should be conducted at the first 30 minute and 24 hour intervals of satisfactory operation.

- 30 Minute Interval - Check all fasteners for tightness. Adjust and tighten as necessary.
- 24 Hour Interval - Inspect all fan components. Check all fasteners, airfoil retaining ring, the safety cable, and guy wires (if applicable). Adjust and tighten as necessary.

Maintenance

NOTE: Installation and maintenance are to be performed only by qualified personnel who are familiar with local codes and regulations and have experience with this type of equipment.

Once the fan has been put into operation, a periodic maintenance program should be set up to ensure reliable fan performance. A proper maintenance program will help deliver years of dependable service. Items to be included in this program are as follows:

1. Verify that all fasteners are tight and properly torqued.
2. Verify that all of the fan's safety systems (safety cable, airfoil retaining ring, and guy wires – if applicable) are properly installed. Inspect for signs of damage or failure. Safety cable and guy wire tension should also be checked. Safety cable should be wrapped around the building structure leaving as little slack as possible. Guy wires should be under enough tension to prevent any lateral movement of the motor and downtube (if applicable).
3. Inspect the fan for signs of fatigue, corrosion, or wear.
4. Impellers require little attention when moving clean air. Occasionally, oil and dust may accumulate causing imbalance. When this occurs, clean the impeller and other fan components to ensure smooth and safe operation. Remove any accumulated dust and dirt using hot water or mild cleaning solutions. Harsh chemicals should not be used to clean the fan as they may damage the fan's finish or motor.

IMPORTANT: Do not allow water or solvents to enter the motor. Under no circumstances should motors be sprayed with steam, water or solvents.

5. Motor maintenance is generally limited to cleaning. Limit cleaning to exterior surfaces only. Removing dust buildup on motor housing ensures proper motor cooling.
6. Prior to restarting unit, check all fasteners for tightness each time maintenance checks are performed.

Modbus Registers

The DC fan's VFD is configured for Modbus RTU communication as standard. The Modbus register list is for applications where a building management system or field-supplied control are to be used for fan operation.

Register	Name	R/W	Retentive	Signed	Format	Range	Default	Description	Detail		
Control	1	Run Command	R/W			x	0,1,2		0=Stop=clear Fault(s); 1=Reverse; 2=Forward; 99=Reset		
	2	Speed Reference	R/W			xxx	1...100		Percentage of full speed/torque		
	3	Operational Status	R			x	0...6		1=Comm CRC errors, 2=Drive Faulted, 3=Motor temp warning, 4=IGBT temp warning, 5=Drive Inhibited (Fire Input), 6=Wind Shut Down active		
	4	Light Control	R/W			xxx	0..100	0	J5 0-10V Output for Optional Light Control (%)	Resets to 0 after power cycle	
	5	External Temperature	R			xxxxx	-400..1100		External Temp (°C) (0.1 unit)	Based off an external 10K @ 25C NTC thermistor	
Fault	6	Last Fault Code	R	R		xxx			Integer code representing fault history	At each fault occurrence, values are shifted to next register and the current fault is displayed in Last Fault Code. Values are retained after power cycle.	
	7	Second Last Fault	R	R		xxx					
	8	Third Last Fault	R	R		xxx					
	9	Fourth Last Fault	R	R		xxx					
	10	Fifth Last Fault	R	R		xxx					
Diagnostics	11	Firmware Version	R	R		xxxxx	1-500		Incremental Version Count		
	12	Operating Hours	R	R		xxxxx	0-65535		Operating hours (driving motor)	MAX 65535	
	13	Motor RPM	R		S	xxx	-300...300		Motor RPM (0.1 rpm)		
	14	Voltage, DC Bus	R			xxx	0...1000		Bus Voltage (Volts) (1 units)		
	15	Voltage, Output RMS	R			xxx	0...1000		RMS Modulated Output Voltage (Volts) (1 units)		
	16	Current, Motor RMS	R			xx.x	0...150		RMS Motor current (Amps) (0.1 units)		
	17	Temperature, Motor	R		S	xxx.x	-300...1100		Motor Temp (°C) (0.1 units)		
	18	Temperature, Transistor	R		S	xxx.x	-400...1250		Transistor Temp (°C) (0.1 units)	Transistor to Heatsink	
	19	Temperature, MCU	R		S	xxx.x	-300...1350		MCU Temp (°C) (0.1 units)		
	20	Thermal Speed Derate	R			xxx	0...100		Speed/Torque derate based on overtemp (%)	Thermal regulation (Motor and/or Drive)	
	21	Communication Errors	R			xxx	0-65535		Number of errors since last power cycle	0-65535	
	22	-- Spare --	R					0			
	23	-- Spare --	R					0			
	24	-- Spare --	R					0			
	25	-- Spare --	R					0			
Configuration	26	KEEP ALIVE (WatchDog)	R/W	R		xxxxx	0-65535	30	Seconds	Any message resets; if a timeout occurs, fan will stop (if running)	
	27	MODBUS Serial Speed	R/W			x	0...9	5	Baud Rate Setting (SW2: Pin 7 ON)	0	1200 bps
										1	2400 bps
										2	4800 bps
										3	9600 bps
										4	19200 bps
										5	38400 bps
6										57600 bps	
7	115200 bps										
28	Motor Type	R/W				0..2	0	13,70,170	0=13; 1 = 70; 2=170		
29	MODBUS Device ID	R/W	R			1-247	2	New Device ID is set after power cycle	SW2 PIN 8 must be set (on) for this to take effect		
30	-- Spare --	R/W					0				

NOTE: Registers 1000-1150 are reserved for internal Diagnostics and Testing.

Maintenance Log

Date _____ Time _____ AM/PM

Notes: _____

Date _____ Time _____ AM/PM

Notes: _____

Date _____ Time _____ AM/PM

Notes: _____

Date _____ Time _____ AM/PM

Notes: _____

Date _____ Time _____ AM/PM

Notes: _____

Date _____ Time _____ AM/PM

Notes: _____

Date _____ Time _____ AM/PM

Notes: _____

Date _____ Time _____ AM/PM

Notes: _____

Date _____ Time _____ AM/PM

Notes: _____

Date _____ Time _____ AM/PM

Notes: _____

Date _____ Time _____ AM/PM

Notes: _____

Date _____ Time _____ AM/PM

Notes: _____



Troubleshooting

DANGER

Disconnect and secure to the 'OFF' position all electrical power to the fan prior to inspection or servicing. Failure to comply with this safety precaution could result in serious injury or death.

DANGER

Pour écarter les risques de blessure grave ou de mort, débrancher et verrouiller l'alimentation électrique en position « Arrêt » avant tout contrôle ou entretien.

Each fan bears a manufacturer's nameplate with the fan's model number and a unique serial number for identification. This information will assist the local representative and the manufacturer in providing service and replacement parts.

PROBLEM	CAUSE	CORRECTIVE ACTION
Reduced airflow	Fan speed too low	Increase fan speed
	Fan operating in reverse	Reverse the direction of operation using the fan controller
	Excessive dirt buildup on impeller	Clean impeller
Excessive noise	Excessive vibration	Clean dirt buildup from impeller. Check all setscrews and fasteners for tightness. Check guy wire tension (if applicable).
	Defective motor	Replace motor
	Defective variable frequency drive (VFD)	Replace VFD
Fan does not operate	Electrical supply	Check for switches turned off or disconnected. Check for correct supply voltage. Check fuses/circuit breakers. In the event of blown fuses, contact the factory before proceeding with troubleshooting.
	Motor/VFD system	Check for faults. Refer to controller instruction manual.

Fault Code Causes and Possible Solutions

CODE	FAULT	DESCRIPTION
0	No Fault	
1	Modbus Timeout	No activity on Modbus (check control connection)
2	Impact Detection	Unexpected change in speed and/or torque indicates impact
3	Motor Over Temperature	Motor temperature exceeds 110°C
4	Drive Over Temperature	Drive components over 110°C
5	Bus Over Voltage	DC Bus voltage is greater than 385v
6	Bus Under Voltage	DC Bus voltage is less than 140v
7	Phase Over Current	Phase Current is greater than 6A RMS
8	Microcontroller High Temp	Microcontroller Unit Temperature is greater than 110°C
9	Overspeed Fault	Blade Speed is greater than 300 rpm

Our Commitment

As a result of our commitment to continuous improvement, Greenheck reserves the right to change specifications without notice.

Product warranties can be found online at Greenheck.com, either on the specific product page or in the literature section of the website at Greenheck.com/Resources/Library/Literature.

AMCA Publication 410-96, Safety Practices for Users and Installers of Industrial and Commercial Fans, provides additional safety information. This publication can be obtained from AMCA International, Inc. at www.amca.org.

