

Installation, Operation and Maintenance Manual

Please read and save these instructions for future reference. Read carefully before attempting to assemble, install, operate or maintain the product described. Protect yourself and others by observing all safety information. Failure to comply with these instructions will result in voiding of the product warranty and may result in personal injury and/or property damage.



Table of Contents

General Louver Installation Instructions	2
Single Section Wide x Single Section High Installation	3
Single Section Wide x Multi Section High Installation.	4
Multi Section Structural Support Tables	5
Multi Wide x Single Section High - Unsupported	6
Multi Wide x Single Section High - Supported	7
Multi Section Wide x Multi Section High Installation .	8

Receiving and Handling

Upon receiving louvers, check for both obvious and hidden damage. If damage is found, record all necessary information on the bill of lading and file a claim with the final carrier. Check to be sure that all parts of the shipment, including accessories are accounted for.

Safety Warning

Improper installation, adjustment, alteration, service or maintenance can cause property damage, injury or death. Read the installation, operating, and maintenance instructions thoroughly before installing or servicing this equipment.

General Louver Installation Instructions

Installation Instructions

1. Locate all crates, boxes, cartons, etc.
2. Use care when handling louver sections to prevent damage. Louvers are to be carefully lifted by the louver frame or supports. Use multiple lifting points when possible to avoid deformation or distortion of louver components. **DO NOT LIFT LOUVERS BY THE LOUVER BLADES.** Use appropriate caution to prevent damage to the louver finish.
3. Remove louvers and any provided accessories from the packaging and inspect for damages. Verify louver dimensions and that all required pieces are present.
4. Single section louvers will ship fully assembled. Multiple section assemblies will ship as individual louver sections to be combined into the larger assembly at installation. Large multiple section louver assemblies may ship in multiple crates.
5. All louver sections will have a factory applied louver label affixed. This label will identify the louver size and a Tag identification if one was provided during the order process.
6. Verify that all required installation hardware is available, to include mounting angles and fasteners (customer provided or optional manufacturer provided). Inspect the opening for any damage or issues that may affect installation of the louvers. Remove any obstructions or debris as required. Adequate substrate depth must be verified.
7. Check the dimensions of the opening to verify the louver will fit correctly. Check the opening is square and plumb.

Single Section Wide x Single Section High Installation

Figure 1.1

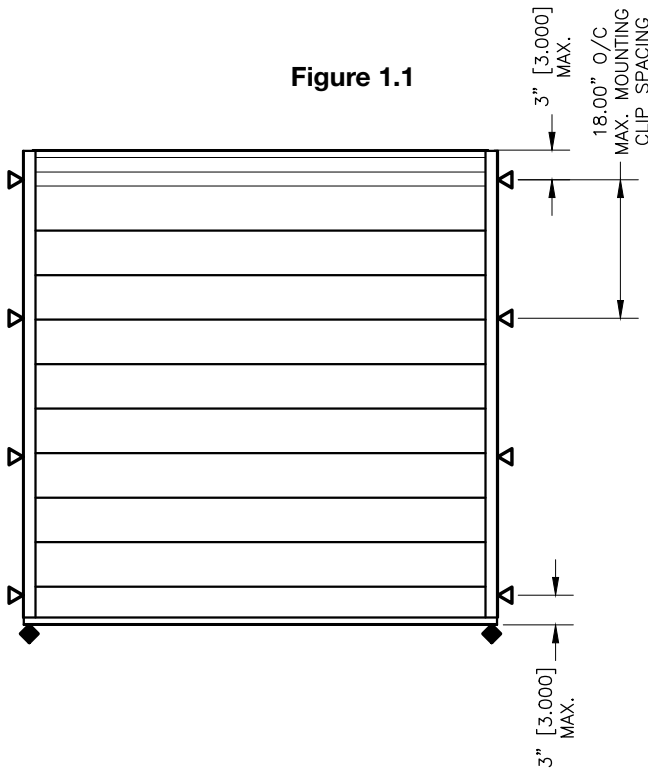

1. Locate the optional extended sill, if provided, and place in the opening. ([Extended Sill Details](#))
2. Locate mounting angles and fasteners required to attach the louver to the structure. Clip angles and fasteners are by others unless the optional mounting angles have been ordered from manufacturer with the louvers. Anchors to the structure are by others and are not manufacturer provided. ([Mounting Clip Details](#))
3. Place the louver in the opening and shim around the perimeter to maintain proper spacing for backer rod and caulk joint.
4. Using the appropriate fasteners, secure the mounting angles to the back of the louver frame at the perimeter.
5. Ensure the louvers is level and in the correct location within the opening and secure the mounting angles to the structure using the correct anchor (by others) for the building substrate material.
6. Once the louver is secured to the structure, install backer rod and caulk around the perimeter of the opening at the front of the louver.
7. If the louvers are equipped with electric actuators, consult the actuator wiring information for wiring by a qualified professional.

Figure 1.2

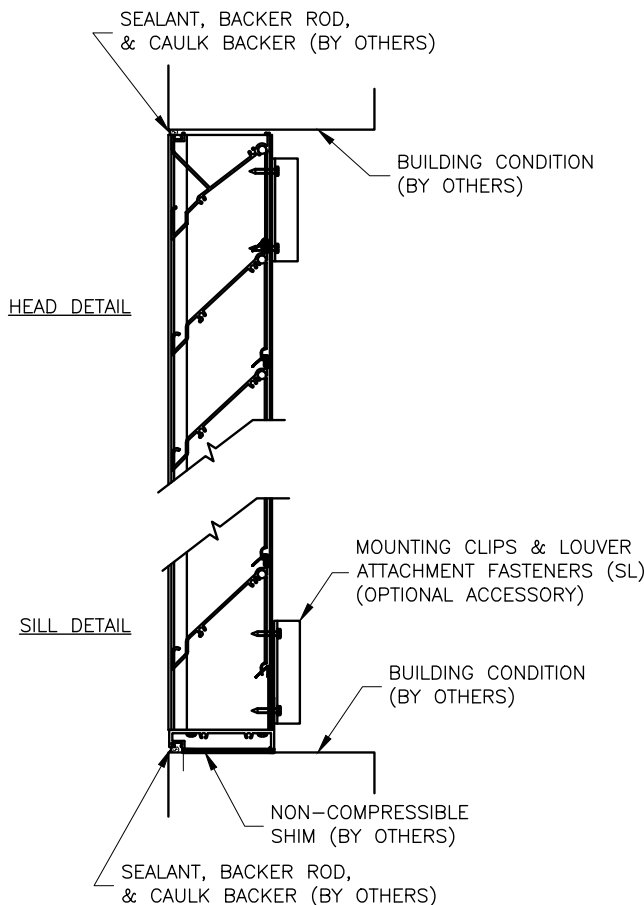
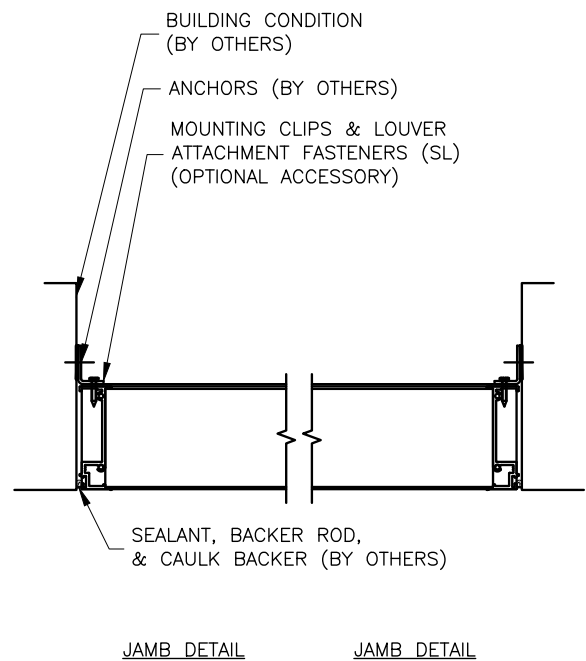

Figure 1.3



Single Section Wide x Multiple Section High Installation

Figure 2.1

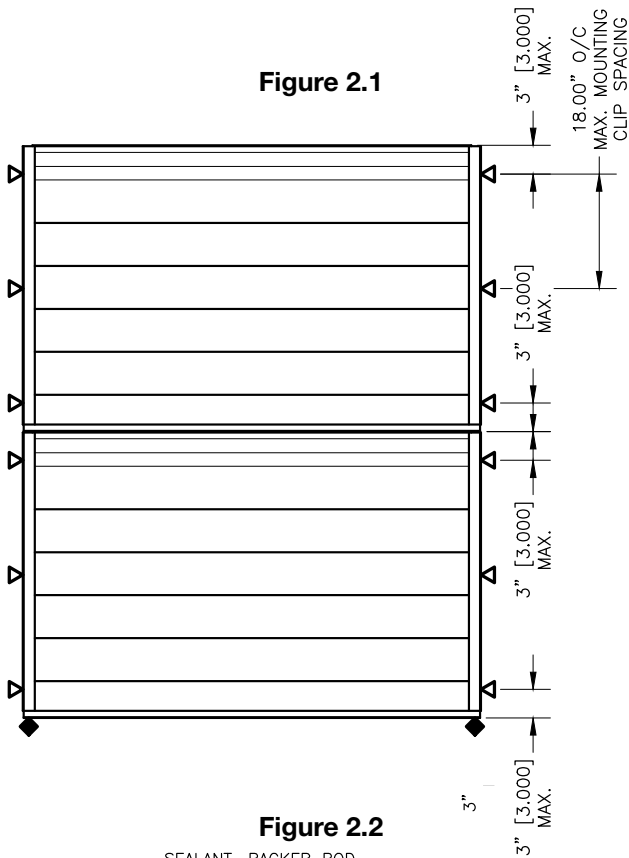
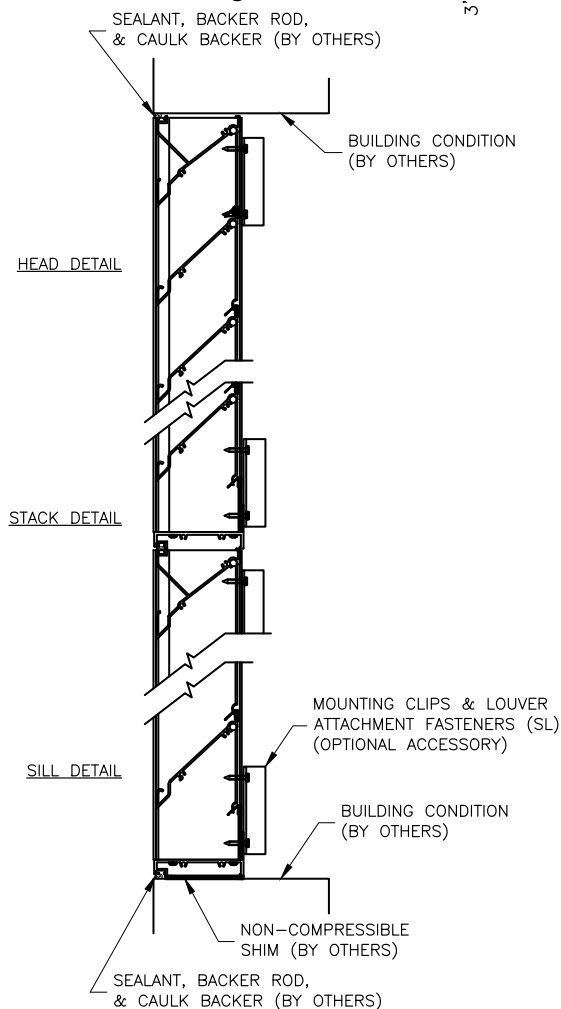

Figure 2.2



1. Locate the optional extended sill, if provided, and place in the opening. ([Extended Sill Details](#))
2. Locate mounting angles and fasteners required to attach the louver to the structure. Clip angles and fasteners are by others unless the optional mounting angles have been ordered from manufacturer with the louvers. Anchors to the structure are by others and are not manufacturer provided. ([Mounting Clip Details](#))
3. Place the lower louver in the opening and shim around the perimeter to maintain proper spacing for backer rod and caulk joint.
4. Using the appropriate fasteners, secure the mounting angles to the back of the louver frame at the perimeter.
5. Ensure the louver is level and in the correct location within the opening and secure the mounting angles to the structure using the correct anchor (by others) for the building substrate material.
6. Carefully place the upper louver in the opening on top of the lower louver verifying proper alignment between the two louvers. Shim around the perimeter to maintain proper spacing for backer rod and caulk joint.
7. Using the appropriate fasteners, secure the mounting angles to the back of the upper louver frame at the perimeter.
8. Ensure the louvers are level and in the correct location within the opening and secure the mounting angles to the structure using the correct anchor (by others) for the building substrate material.
9. Once the louver is secured to the structure, install backer rod and caulk around the perimeter of the opening at the front of the louver as well as the stack joint between the lower louver head and the upper louver sill.
10. If the louvers are equipped with electric actuators, consult the actuator wiring information for wiring by a qualified professional.

Single Section Wide x Multiple Section High Installation Continued

Review Tables 1.1 and 1.2 to determine if an additional structural support will be required based on the louver section width and height of the louvers being installed. If additional support is not required, reference the Multiple Section Wide and Single Section High-Unsupported installation instructions. If additional support is required, reference the Multiple Section Wide and Single Section High-Supported installation instructions.

Figure 2.3

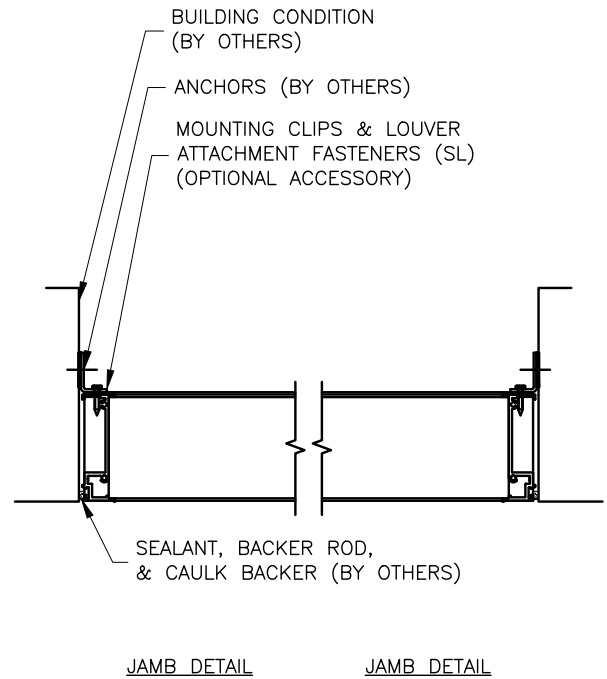

Multiple Section Structural Support

For multiple section wide and single section high louver installation, review Tables to determine if an additional structural support will be required based on the louver section width and height of the louvers being installed. If additional support is not required, reference the Multiple Section Wide and Single Section High-Unsupported installation instructions. If additional support is required, reference the Multiple Section Wide and Single Section High-Supported installation instructions.

Table 1.1

ECD-601	
Maximum Unsupported Height	
Section Width (In.)	At 25 PSF Wind Load (In.)
<= 36	120
<= 84	108
<= 120	84

Table 1.2

ECD-401	
Maximum Unsupported Height	
Section Width (In.)	At 25 PSF Wind Load (In.)
<= 38	120
<= 48	108
<= 60	96
<= 84	78
<= 108	72
<= 120	66

Multiple Section Wide x Single Section High Installation - Unsupported

Figure 3.1

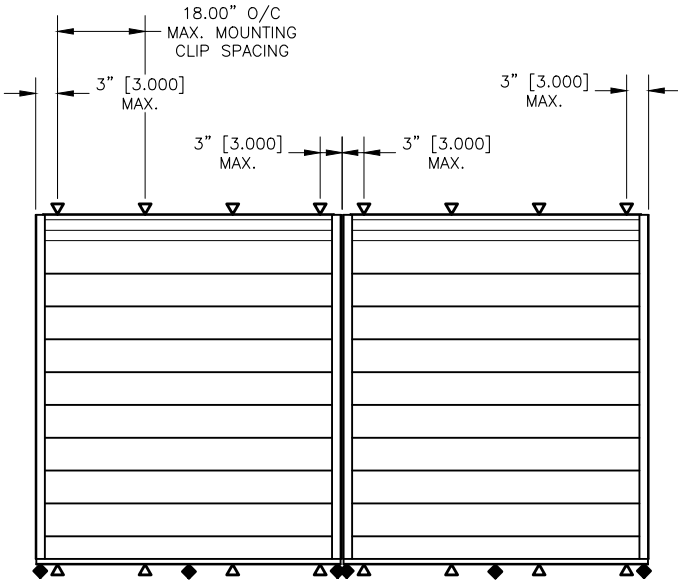

1. Locate the optional extended sill, if provided, and place in the opening. ([Extended Sill Details](#))
2. Locate mounting angles and fasteners required to attach the louver to the structure. Clip angles and fasteners are by others unless the optional mounting angles have been ordered from manufacturer with the louvers. Anchors to the structure are by others and are not manufacturer provided. ([Mounting Clip Details](#))
3. Place the left louver section (as viewed from the exterior) in the opening and shim around the perimeter to maintain proper spacing for backer rod and caulk joint.
4. Using the appropriate fasteners, secure the mounting angles to the back of the louver frame at the perimeter.
5. Ensure the louvers is level and in the correct location within the opening and secure the mounting angles to the structure using the correct anchor (by others) for the building substrate material.
6. Place the next lower louver section to the right of the first lower louver section. Shim around the perimeter to maintain proper spacing for backer rod and caulk joint. Incorporate a joint of 0.25 inches at the vertical mullion condition unless otherwise noted on submitted details. Repeat steps 4-5 above to secure the louver to the structure.
7. Follow the same procedure for any additional sections to the right.
8. Once the louver assembly is secured to the structure, install backer rod and caulk around the perimeter of the opening at the front of the louver as well as the mullion joint between the louver jambs.
9. If the louvers are equipped with electric actuators, consult the actuator wiring information for wiring by a qualified professional.

Figure 3.2

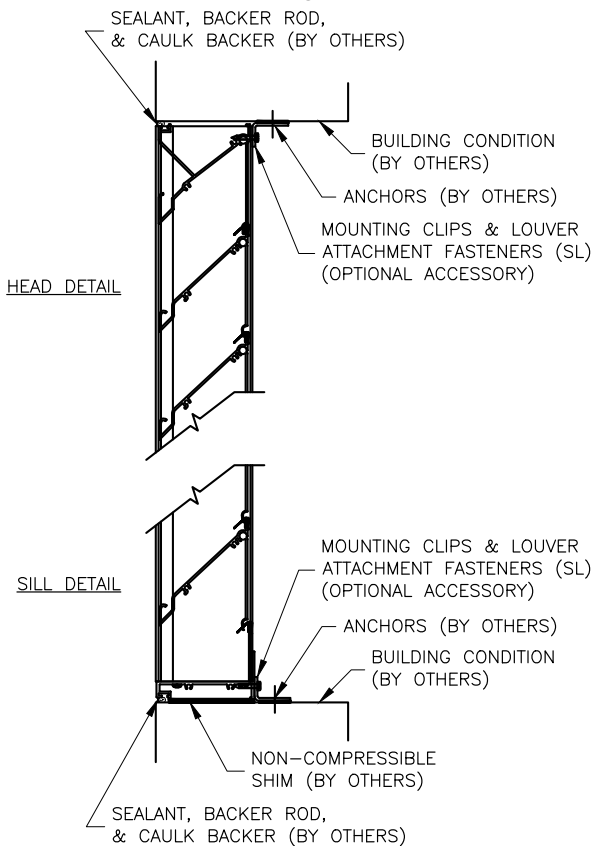
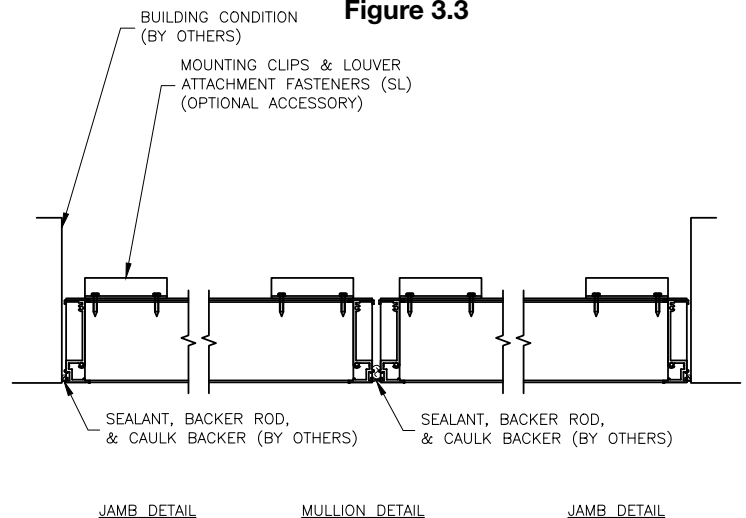

Figure 3.3



Multiple Section Wide x Single Section High Installation - Supported

Figure 4.1

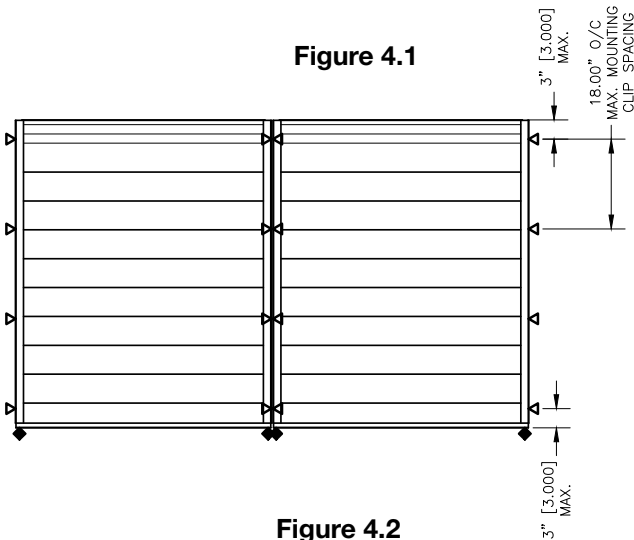

Figure 4.2

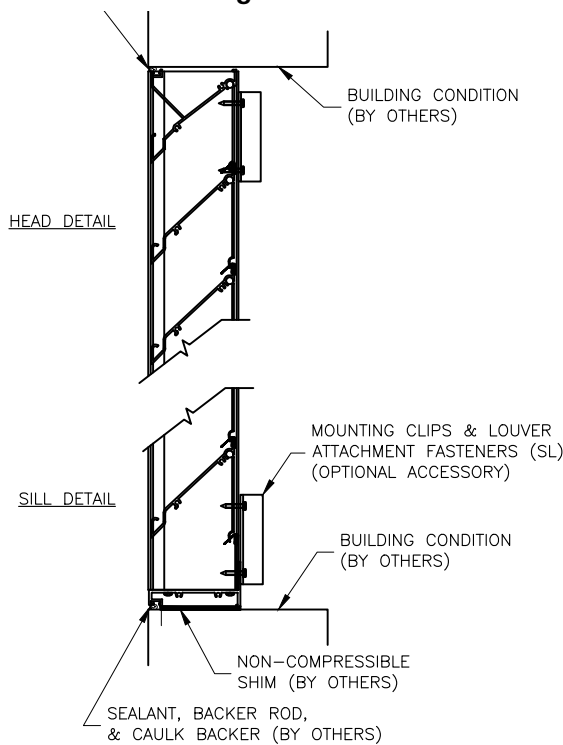

Figure 4.3

Structural Reinforcing (by others)

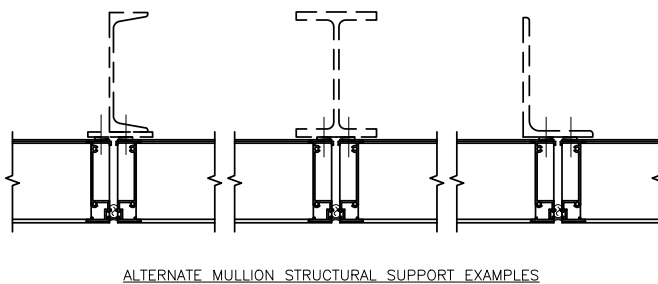
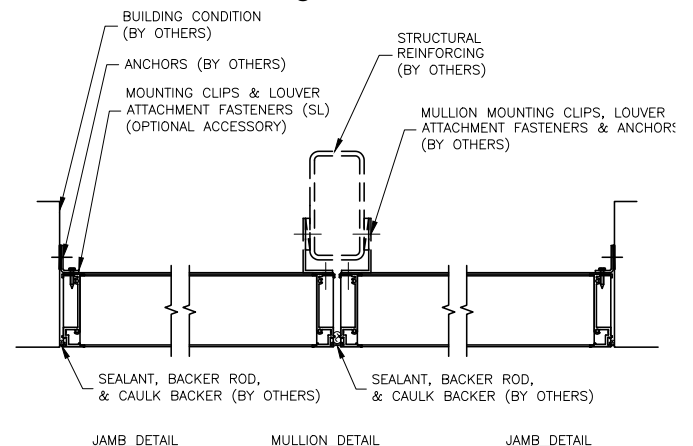

Figure 4.4



1. Locate the optional extended sill, if provided, and place in the opening. ([Extended Sill Details](#))
2. Locate mounting angles and fasteners required to attach the louver to the structure. Clip angles and fasteners are by others unless the optional mounting angles have been ordered from manufacturer with the louvers. Anchors to the structure are by others and are not manufacturer provided. ([Mounting Clip Details](#))
3. Place the left louver section (as viewed from the exterior) in the opening and shim around the perimeter to maintain proper spacing for backer rod and caulk joint.
4. Using the appropriate fasteners, secure the mounting angles to the back of the louver frame at the perimeter.
5. Ensure the louvers is level and in the correct location within the opening and secure the mounting angles to the structure using the correct anchor (by others) for the building substrate material.
6. Place the next lower louver section to the right of the first lower louver section. Shim around the perimeter to maintain proper spacing for backer rod and caulk joint. Incorporate a joint of 0.25 inches at the vertical mullion condition unless otherwise noted on submitted details. Repeat steps 4-5 above to secure the louver to the structure.
7. Follow the same procedure for any additional sections to the right.
8. Install additional structural supports (not by manufacturer) at the vertical louver mullion. Secure the louver frame to the structural support with the appropriate mounting angles and/or fasteners (not by manufacturer).
9. Once the louver is secured to the structure, install backer rod and caulk around the perimeter of the opening at the front of the louver as well as the stack joint between the lower louver head and the upper louver sill.
10. If the louvers are equipped with electric actuators, consult the actuator wiring information for wiring by a qualified professional.

Multiple Section Wide x Multiple Section High Installation

Larger opening sizes require field assembly of multiple louver sections to make up the overall opening size. Individual louver sections are designed to withstand a 25 psf wind load. Structural reinforcing members may be required to adequately support and install multiple louver sections within a large opening. Structural reinforcing members along with any associated installation hardware is not provided by manufacturer unless indicated otherwise by manufacturer.

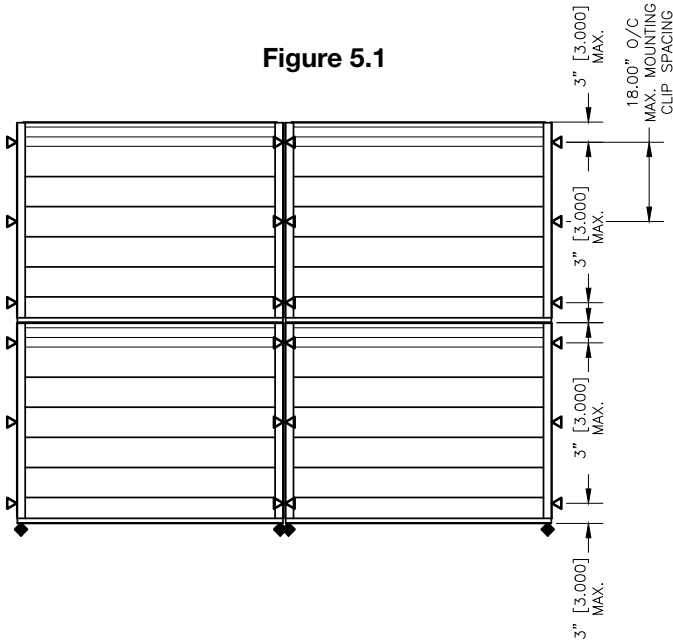

1. Locate the optional extended sill, if provided, and place in the opening. ([Extended Sill Details](#))
2. Locate mounting angles and fasteners required to attach the louver to the structure. Clip angles and fasteners are by others unless the optional mounting angles have been ordered from manufacturer with the louvers. Anchors to the structure are by others and are not manufacturer provided. ([Mounting Clip Details](#))
3. Place the lower left louver section (as viewed from the exterior) in the opening and shim around the perimeter to maintain proper spacing for backer rod and caulk joint.
4. Using the appropriate fasteners, secure the mounting angles to the back of the louver frame at the perimeter.
5. Ensure the louver is level and in the correct location within the opening and secure the mounting angles to the structure using the correct anchor (by others) for the building substrate material.
6. Place the next lower louver section to the right of the first lower louver section. Shim around the perimeter to maintain proper spacing for backer rod and caulk joint. Incorporate a joint of 0.25 inches at the vertical mullion condition unless otherwise noted on submitted details. Repeat steps 4-5 above to secure the louver to the structure.
7. Follow the same procedure for any additional lower louver sections to the right.
8. Carefully place the upper left louver in the opening on top of the lower left louver verifying proper alignment between the two louvers. Shim around the perimeter to maintain proper spacing for backer rod and caulk joint. Repeat steps 4-5 above to secure the louver to the structure.
9. Carefully place the next upper louver to the right of the first upper louver section stacking it on top of the lower Louver. Verify proper alignment between the louvers. Shim around the perimeter to maintain proper spacing for backer rod and caulk joint. Repeat steps 4-5 above to secure the louver to the structure.
10. Follow the step 9 procedure for any additional upper sections to the right.
11. Additional structural supports (not designed or provided by Greenheck) will be required and will need to be installed behind the louver mullions at this point. The louvers must be secured to the structural support using the appropriate mounting angles and fasteners (by others)
12. Once the louver assembly is secured to the structure, install backer rod and caulk around the perimeter of the opening at the front of the louvers.
13. If the louvers are equipped with electric actuators, consult the actuator wiring information for wiring by a qualified professional.

Multiple Section Wide x Multiple Section High Installation Continued

Figure 5.2

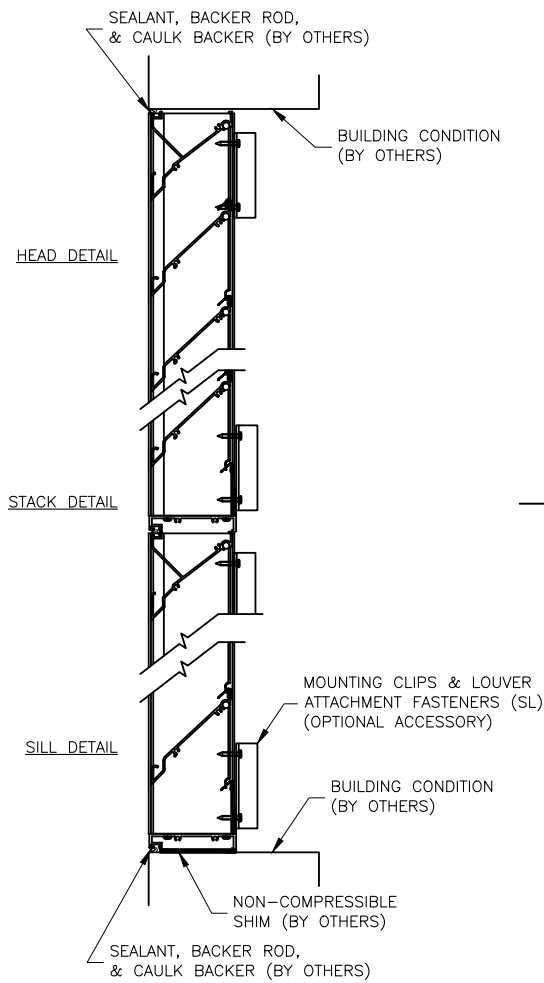

Figure 5.3
Structural Reinforcing (by others)

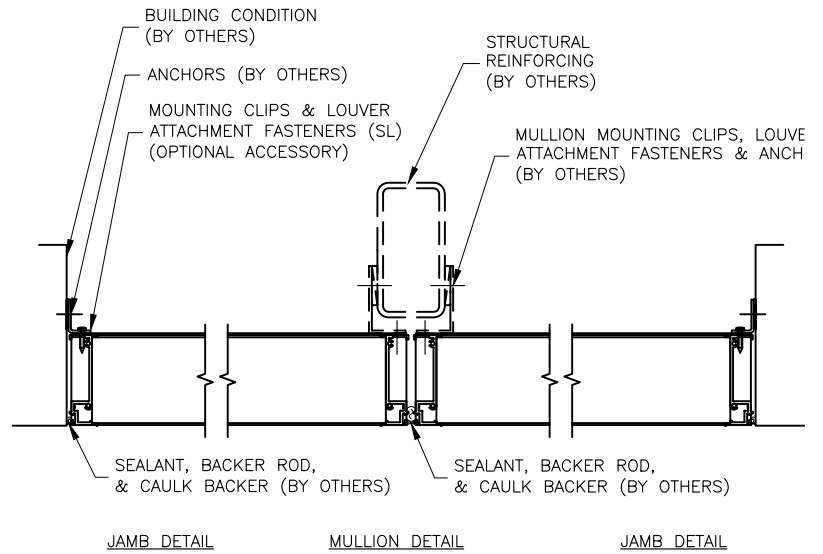
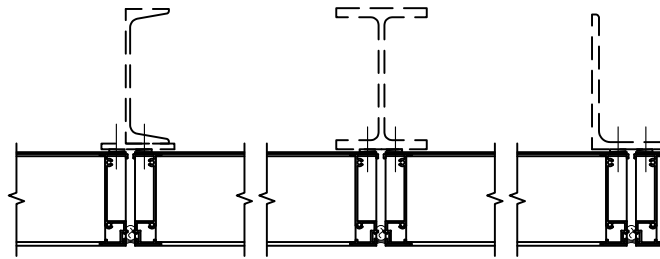

Figure 5.4



ALTERNATE MULLION STRUCTURAL SUPPORT EXAMPLES

Our Commitment

As a result of our commitment to continuous improvement, Greenheck reserves the right to change specifications without notice.

Product warranties can be found online at Greenheck.com, either on the specific product page or in the literature section of the website at Greenheck.com/Resources/Library/Literature.

Greenheck's Louver Models catalog provides additional information describing the equipment, fan performance, available accessories, and specification data.

AMCA Publication 410-96, Safety Practices for Users and Installers of Industrial and Commercial Fans, provides additional safety information. This publication can be obtained from AMCA International, Inc. at www.amca.org.

