

## Installation, Operation and Maintenance Manual

Please read and save these instructions for future reference. Read carefully before attempting to assemble, install, operate or maintain the product described. Protect yourself and others by observing all safety information. Failure to comply with these instructions will result in voiding of the product warranty and may result in personal injury and/or property damage.



### General Safety Information

Only qualified personnel should install this unit. Personnel should have a clear understanding of these instructions and should be aware of general safety precautions. Improper installation can result in electric shock, possible injury due to coming in contact with moving parts, as well as other potential hazards. Other considerations may be required if high winds or seismic activity are present. If more information is needed, contact a licensed professional engineer before moving forward.

1. Follow all local electrical and safety codes, as well as the National Electrical Code (NEC), the National Fire Protection Agency (NFPA), where applicable. Follow the Canadian Electrical Code (CEC) in Canada.
2. Do not allow the power cable to kink or come in contact with oil, grease, hot surfaces, or chemicals. Replace cord immediately if damaged.
3. Verify the power source is compatible with the equipment.

### Table of Contents

General Safety Information . . . . .	1-2
Vektor System Control (VSC) Components . . . . .	3
Variable Frequency Drive Operation . . . . .	3
Quick Installation Guide . . . . .	4
Vektor System Control (VSC) Function Overview . . . . .	5
Component Mounting . . . . .	6
Component Hardwiring . . . . .	7-10
Optional Hardwire Connections Digital Input . . . . .	11-12
Digital Input Programming . . . . .	13
Determining Parameters . . . . .	14-29
System Startup and Testing . . . . .	30
VFD Setup . . . . .	31-37
BACnet™ Objects . . . . .	38-40
Troubleshooting . . . . .	41-42
Controller Settings Reference . . . . .	43
Our Commitment. . . . .	Backcover

#### DANGER

Always disconnect, lock and tag power source before installing or servicing. Failure to disconnect power source can result in fire, shock or serious injury.

#### CAUTION

When servicing the fan, motor may be hot enough to cause pain or injury. Allow motor to cool before servicing.

#### CAUTION

Precaution should be taken in explosive atmospheres.

#### DANGER

Pour écarter les risques d'incendie, de choc électrique ou de blessure grave, veiller à toujours débrancher, verrouiller et étiqueter la source de courant avant l'installation ou l'entretien.

#### ATTENTION

Lors de toute intervention sur la soufflante, le moteur peut être suffisamment chaud pour provoquer une douleur voire une blessure. Laisser le moteur refroidir avant toute maintenance.

#### ATTENTION

Faire preuve de précaution dans les atmosphères explosives.

## General Safety Information (cont.)

---

### Receiving

Upon receiving the components, check to ensure all items are accounted for by referencing the delivery receipt or packing list. Inspect each crate or carton for shipping damage before accepting delivery. Alert the carrier of any damage detected. The customer will make a notation of damage (or shortage of items) on the delivery receipt and all copies of the bill of lading which is countersigned by the delivering carrier. If damaged, immediately contact your local sales representative. Any physical damage to the unit after acceptance is not the responsibility of the manufacturer.

### Unpacking

Verify that all required parts and the correct quantity of each item have been received. If any items are missing; report shortages to your local representative to arrange for obtaining missing parts. Sometimes it is not possible that all items for the unit be shipped together due to availability of transportation and truck space. Confirmation of shipment(s) must be limited to only items on the bill of lading.

### Handling

Handle in such a manner as to keep from scratching or chipping the coating. Damaged finish to parts may reduce ability of unit to resist corrosion.

### Storage

Units are protected against damage during shipment. If the unit cannot be installed and operated immediately, precautions need to be taken to prevent deterioration of the unit during storage. The user assumes responsibility of the unit and accessories while in storage. The manufacturer will not be responsible for damage during storage. These suggestions are provided solely as a convenience to the user.

**INDOOR** - The ideal environment for the storage of units and accessories is indoors, above grade, in a low humidity atmosphere which is sealed to prevent the entry of blowing dust, rain, or snow. Temperatures should be evenly maintained between 30°F (-1°C) and 110°F (43°C) (wide temperature swings may cause condensation and “sweating” of metal parts). All accessories must be stored indoors in a clean, dry atmosphere. Remove any accumulations of dirt, water, ice, or snow and wipe dry before moving to indoor storage. To avoid “sweating” of metal parts, allow cold parts to reach room temperature. To dry parts and packages use a portable electric heater to eliminate any moisture build up. Leave coverings loose to permit air circulation and to allow for periodic inspection. The unit should be stored at least 3-1/2 in. (89 mm) off the floor on wooden blocks covered with moisture proof paper or polyethylene sheathing. Aisles between parts and along all walls should be provided to permit air circulation and space for inspection.

### Inspection and Maintenance during Storage

While in storage, inspect equipment once per month. Keep a record of inspection and maintenance performed. If moisture or dirt accumulations are found on parts, the source should be located and eliminated.

### Removed From Storage

As units are removed from storage to be installed in their final location, they should be protected and maintained in a similar fashion, until the equipment goes into operation. Prior to installing the unit and system components, inspect the unit assembly to make sure it is in working order. Check all fasteners and accessories for tightness.

# Vektor System Control (VSC) Components



Programmable Logic Controller (PLC)  
Control Box  
(1 per fan system)



Variable Frequency Drive (VFD)  
(1 per fan)  
VFD Brand and Model may  
vary from image.



Pressure Transducer  
(1 per fan system)



Pressure Tubing  
(25 feet)



Pressure Probe  
(1 per fan system)



5 Pin, 16.4 feet (5 meter) cable  
[2 per fan]  
8 Pin, 32.8 feet (10 meter) cable  
[3 per fan system]

## Customer-Supplied System Components

- Control wiring and conduit from pressure transducer to control box
- Mounting hardware for all components
- Power wiring and conduit to controller box, VFD(s) and from VFD(s) to motor(s).

## Variable Frequency Drive Operation

For operation with a variable frequency drive (VFD) always check motor amps when adjusting the operating frequency. Motor may be sized for the original selected operating speed under 60 Hz. Bypassing the VFD or increasing the speed from this original selection, even if less than 60 Hz, may cause motor to overload or fail. Consult factory with fan serial number before increasing the upper limiting frequency.

Always check the fan RPM when adjusting the operating frequency. Do not exceed maximum class fan RPM of the wheel.

### NOTE

It is the responsibility of the installing body to perform coast-down tests and identify any resonant frequencies after the equipment is fully installed. These resonant frequencies are to be removed from the operating range of the fan by using the "skip frequency" function in the VFD programming. Failure to remove resonant frequencies from the operating range will decrease the operating life of the fan and void the warranty.

# Quick Installation Guide

## System Mounting & Wiring

Steps 2, 3, 7 and 9 need to be repeated for multiple fan systems.

All wiring done by others to be per local code (see figure 1).

1. Mount control box upright with connectors down on structural support within 50 ft (15.2 m) of fan plenum.  
Note: control box is labeled with a fan mark. This must match the fan mark on the fan system being connected.
2. Mount Variable Frequency Drive(s) (VFD) within 20 ft (6.1 m) of control box (1 per fan).  
Note: VFD is labeled with a fan mark. This must match the fan mark on the fan system.
3. Connect 5 pin cable from VFD1 to control box VFD1. Maintain 12 inches from all high power cables when routing.
4. Connect 8 pin cable from damper junction box on fan plenum to control box connection labeled Plenum.
5. Wire static pressure transducer to control box. Plumb pressure probe to pressure transducer-port.
6. Wire optional connections on terminal strip, see **Optional Hardwire Connections Digital Input** section.
7. Wire incoming power to VFD1.
8. Wire incoming power to control box.
9. Wire from VFD1 to motor on FAN1.

### Start-up:

1. Confirm incoming voltage and motor nameplate data match the VFD(s) label.
2. Confirm the fan mark on the VFD(s) and control box match the fan mark on the fan.
3. Apply power to VFD(s).
4. Turn on disconnect located on VFD(s) and/or local fan disconnect(s).
5. Set the VFD Modbus address for Fan 1 to 1 and for Fan 2 to 2. See **System Startup and Testing** section.
6. Press the *Auto On* button on the VFD(s) keypad.
7. Apply power to the control box.
8. Confirm pressure transducer is powered on; the digital display on the pressure transducer will illuminate.
9. Configure optional wire connections. See **Optional Hardwire Connections Digital Input** for details.
10. Confirm the system can be turned on safely without damage to duct work.
11. Using CAREL® keypad located in control box, use *Up* and *Down* arrows to navigate to *System On/Off*. Press *Enter* button to turn the system on.
12. Follow the System Startup and Testing section to properly start and test the system.
13. The system is factory preset to start up and maintain 1 in. wg; this will need to be adjusted to the user desired static pressure setting.

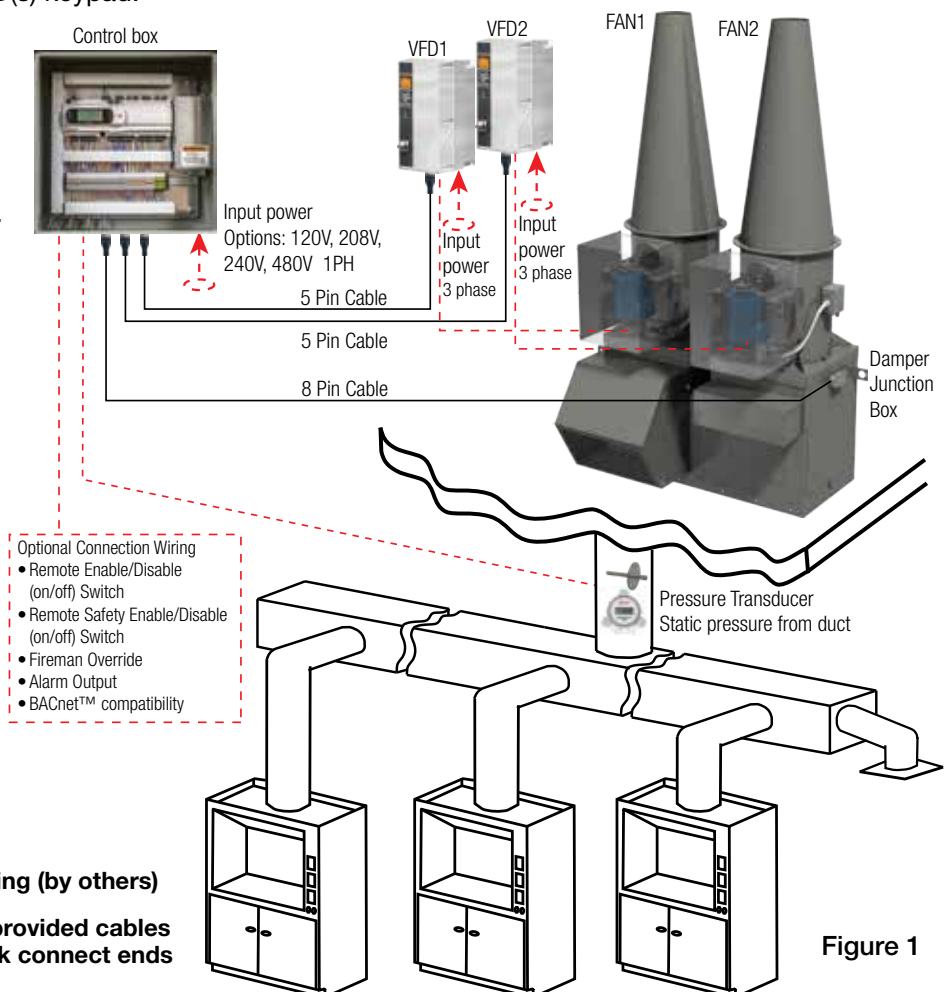

Figure 1

# Vektor System Control (VSC) Function Overview

Vektor System Control (VSC) is a complete factory controls package for use in controlling the dampers and motors on a Vektor fan system. Hardware includes a control box, pressure transducer, and variable frequency drive(s) (VFD) for field mounting. The system operates by receiving an input signal from a duct static pressure sensor and depending on the relation to the set point, adjusts the fan speed and dampers. This system can control up to one bypass and one isolation damper per fan.

Each VSC package will come with one control box that is preprogrammed, ready to control the fan system it was ordered with (see figure 2). A multi-tap transformer will accept single phase 120V, 208V, 240V or 480V input power field wired to a terminal strip. The connections to the VFD(s), isolation damper(s), and bypass damper(s) are made easy with quick connect cables. The pressure transducer connection will be field wired to the terminal strip located in the control box. Systems may not have isolation or bypass dampers; the control box will be programmed accordingly.

Figure 2

Control Box

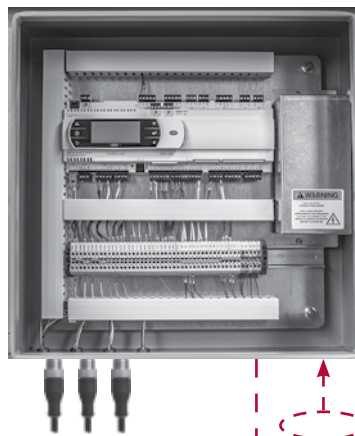

Input Power Options:  
120V, 208V, 240V,  
480V 1PH

Pressure Transducer

Field Wiring (by others)



Quick Connect Cabling

Each VSC package will come with one VFD per fan that is preprogrammed to communicate with the PLC, ready to control the fan motor it was ordered with (see figure 3). Incoming power and output power to the fan motor will be field wired. The connection from the control box to the VFD is made easy with a quick connect cable.

Figure 3

VFD



Output Power to Fan Motor

Input Power 3PH

Field Wiring (by others)

Each VSC package will come with one pressure transducer that is preprogrammed, ready to control the fan system it was ordered with (see figure 4). Three wires will be field wired from the control box terminal strip to the pressure transducer terminal strip. The pressure transducer will receive power from the control box, no additional power source is required. A static pressure probe and tubing to connect the probe to the pressure transducer is factory supplied.

Figure 4

Transducer

VAC  
VDC  
COM  
V out



Field Wiring (by others)

# Component Mounting

## Mounting the Vektor System Control (VSC) Box

- Mount VSC box upright with connectors down on structural support within 50 ft (15.2 m) from center of fan plenum.
- Cables and wiring will be connected to the bottom of the box. It must have a minimum of 12 in. (305 mm) of clearance from any obstructions.
- VSC control box is a NEMA-3R enclosure suitable to be mounted indoors or outdoors.

## Mounting of Variable Frequency Drive(s) (VFD)

- The mounting hole pattern can be found in the manual supplied with the VFD.
- Place the VFD(s) within 20 ft (6.1 m) of the VSC control box.
- Place the VFD(s) as near to the motor as possible, keeping the motor cables as short as possible. Maximum motor cable length to be less than 100 ft (30.5 m).
- Mount the VFD(s) vertically to a solid structure; always use the provided sheet metal backing plate.
- A minimum clearance of 9 in. (229 mm) above and below, 3 in. (76 mm) on each side is required.

### VFD Weathershield Mounting

The weathershield is only required if the VFD is the Danfoss brand and mounted outdoors.

- Weathershield attaches to the top of the VFD using M6x1 fasteners (supplied).
1. Slide the bracket between the VFD mounting surface and the back of the VFD (see figure 5).
  2. Tighten the upper mounting bolts to secure the bracket and VFD(s).
  3. Slide the shield onto the bracket (see figure 6).
  4. Fasten the shield to the bracket with supplied screws.

## Pressure Transducer Mounting

- The pressure transducer is housed in a NEMA-4X rated enclosure suitable to be mounted indoors or outdoors.
- Locate the pressure transducer within 100 ft (30.5 m) of the VSC control box. Two hundred feet is the maximum control wire length for this pressure transducer.
- The pressure transducer should be mounted on a flat vertical surface with the connections directed down to prevent moisture from entering either the pressure ports or the electrical cable entry. The diaphragm must be vertical to minimize gravity effects on the diaphragm.
- The pressure transducer should be mounted higher than the static pressure probe to ensure that any moisture or condensation drains back into the duct.
- Pressure transducer plumbing options:  
Negative static pressure measurement.

Connect the pressure probe to the negative (-) port, as indicated on the transmitter. Leave positive (+) port open to atmosphere.

Figure 5

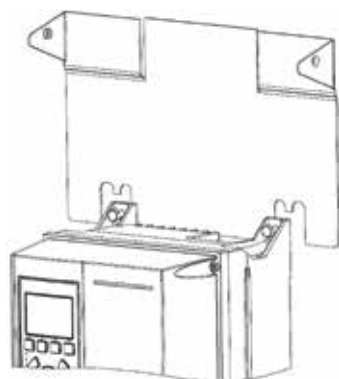
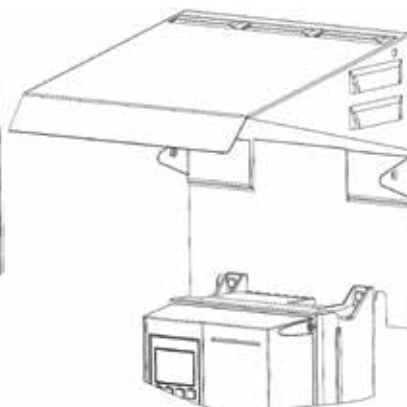

Figure 6



# Component Hardwiring

## System Wiring

### Greenheck supplied cable connections

- Control box to fan plenum
  - 8 pin cable
  - Qty. 3, 32.8 ft (10 m) each. Daisy chain to the length required.
- Control box to VFD(s)
  - 5 pin cable
  - Qty. 2, 16.4 ft (5 m) each. Daisy chain to the length required.

### Contractor supplied cable/connections

- To VFD and Motor
  - Power to each VFD (selected motor voltage), grommet location in bottom of VFD.
  - Power from VFD to motor/disconnect on fan.
- Power to control box
  - Control box has built-in transformer for 24V power to PLC, sensors and actuators.
  - Contractor to drill hole in PLC box and connect conduit per installation location and local codes.
  - To power connect 120V, 1-phase or 1 leg of 3-phase power.
    - (Accepts: 120V, 208V, 230V or 460V)
- Control wiring
  - Recommend using 18-20 ga. wire. Local codes and standards may require other gauge.
  - Contractor to drill hole in the control box and connect conduit per installation location and local codes.
  - Required (yellow highlights on terminal strip image)
    - Duct static pressure sensor to control box. Transducer provided by Greenheck.
    - 24 volt power from control box transformer.
  - Optional hardwire connections (green highlights on terminal strip image)
    - Remote enable/disable (on/off) switch (switch by others)
    - Remote safety enable/disable (on/off) switch (switch by others)
    - Fireman's override (switch by others) Field configured for either ON or OFF.
    - Alarm Output
    - BACnet™ MSTP or BACnet™ IP to Building Management System (BMS)
  - DO NOT connect to red highlights on terminal strip image.

### Control box wiring terminal strip:

1 INPUT	2 INPUT	3 INPUT	4 INPUT	1BYPAS	2BYPAS	ISOL1	ISOL2	SYSON+	SYSON-	SAFE-	SAFE+	FIRE-	FIRE+	ALARM+	ALARM-	1MODBS+	1MODBS-	2MODBS+	2MODBS-	3MODBS+	3MODBS-	+24VAC	+24VAC	+24VAC	+24VAC	+24VAC	COM	COM	COM	COM	COM	COM	GND			
○	○	○	○	○	○	○	○	○	○	○	○	○	○	○	○	○	○	○	○	○	○	○	○	○	○	○	○	○	○	○	○	○	○	○		
○	○	○	○	○	○	○	○	○	○	○	○	○	○	○	○	○	○	○	○	○	○	○	○	○	○	○	○	○	○	○	○	○	○	○		

# Component Hardwiring (continued)

## Control box wiring diagram:

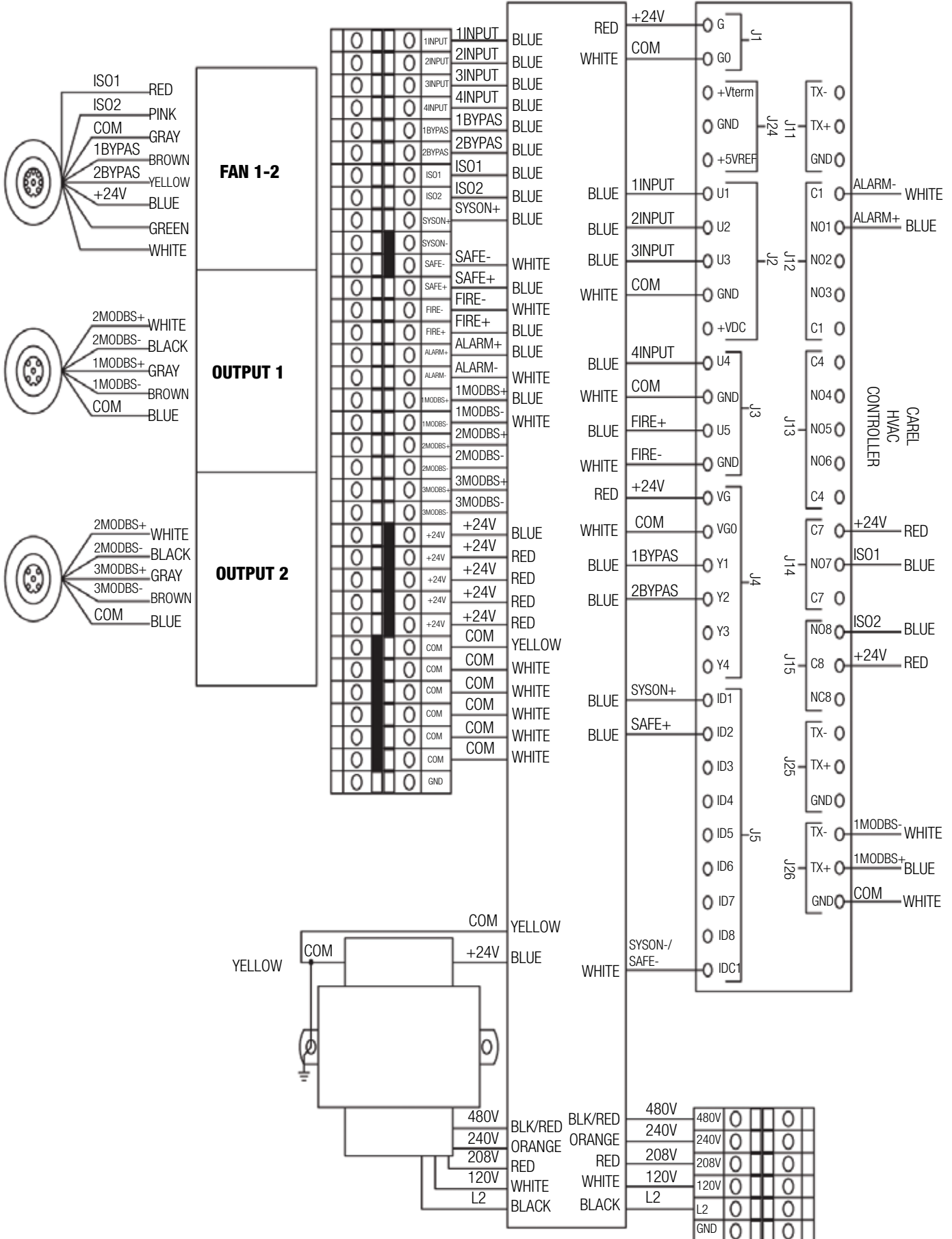



## Damper junction box wiring diagram:

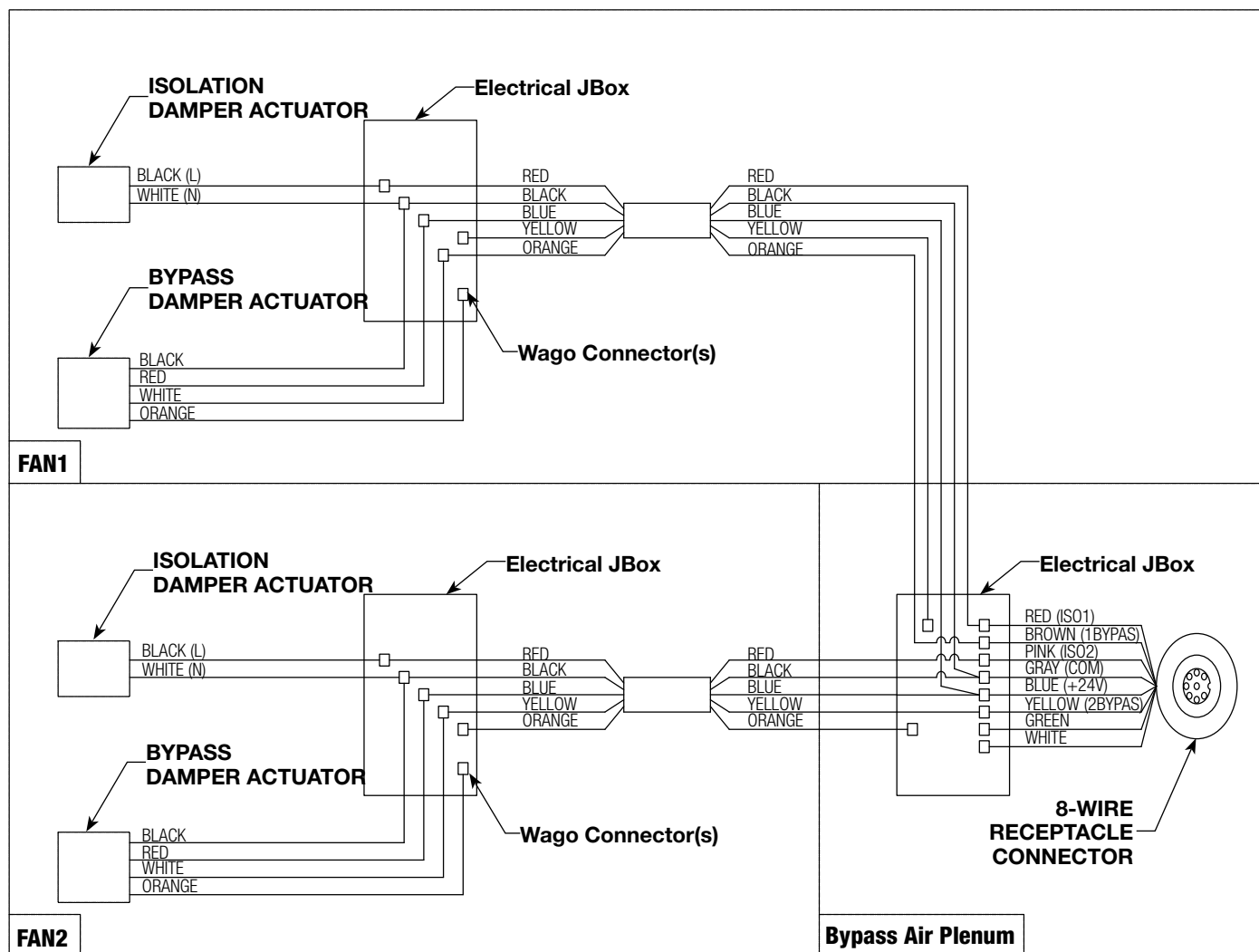

### NOTE

All field installation and wiring of electrical equipment must be done to meet NEC, CEC and local codes.

Be sure to use appropriately sized wire for the full load amp draw.

Once the following hardwiring is complete, please refer to the **Building Management System (BMS) Settings** menu for details on programming the BMS to communicate with the Vektor System Control via the hardwire connections.

Make sure the numbering of the fans is consistent during the entire wiring installation; fan 1 will require wiring specific to fan 1, fan 2 will require specific wiring, if applicable.

### Control Box Incoming Power

(hardwire connections)

The control box will function on 120, 208, 240 or 480V single-phase 50/60 Hz AC. Each control box will draw a maximum of 2 amps. Remove the metal cover located on the right side of the control box to access the terminal strip for incoming power (reference wire

diagram for details on terminal strip landing points). Once the wiring is complete, reinstall the metal cover.

### Control Box to VFD Quick Connect

Connect the factory supplied 5 pin cable (shipped in the control box) to the 5 pin threaded bulkhead on the bottom of the control box; connect the other end to the 5 pin threaded bulkhead on bottom of the VFD(s). Each fan is provided with two (2) – 5 meter cables that can be connected together to extend the length; use as required per fan.

### NOTE

Repeat this step for fan 2, if applicable.

### Control Box to Damper Junction Box

Connect the factory supplied 8 pin cable (shipped in the control box) to the 8 pin threaded bulkhead on bottom of the control box; connect the other end to the 8 pin threaded bulkhead on the damper junction box that is mounted on the fan plenum. Each fan is provided with three (3) - 10 meter cables that can be connected together to extend the length; use as required.

## Component Hardwiring (continued)

### Control Box to Pressure Transducer

(hardwire connections)

Keep control wires as short as possible [100 ft (30.5 m) or less] and separate from high power cables to minimize interference.

Remove the face cover of the pressure transducer by rotating the face cover counterclockwise and pulling outward to access the wiring terminals.

Remove the display by pulling outward noting the orientation of the display. If the display is reinstalled upside down, the numbers will be upside down.

- Connect INPUT1 on the control box terminal strip to the VOUT on the pressure transducer.
- Connect COM on the control box terminal strip to the COM terminal on the pressure transducer.
- Connect +24V on the control box terminal strip to the VAC terminal on the pressure transducer.

#### Pressure Transducer

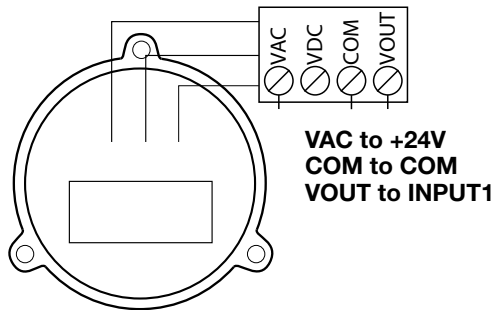

### VFD to Motor Wiring Procedure

(hardwire connections)

#### ABB ACH580:

Remove the cover of the VFD to access the terminal strips.

- Connect incoming 3-phase AC input power to terminals L1, L2 and L3 on the master disconnect.
- Connect the 3-phase motor wiring to terminals T1/U, T2/V and T3/W.
- Connect ground wire to the nearest grounding terminal located on the body of the enclosure.
- Use a cable clamp to relieve pressure from connections.
- Replace VFD cover reusing fasteners.

#### NOTE

Repeat this step for fan 2, if applicable.

### VFD to Motor Wiring Procedure

(hardwire connections)

#### Danfoss FC102 3R:

Remove the eight fasteners on the cover of the VFD using T20 Torx® or flat head screwdriver. An extension may be needed to reach the fasteners. Remove the cover.

- Connect incoming 3-phase AC input power to terminals T1, T2 and T3 on the master disconnect.
- Connect the 3-phase motor wiring to terminals 96 (U), 97 (V) and 98 (W).
- Connect ground wire to the nearest grounding terminal located on the body of the enclosure.
- Use a cable clamp to relieve pressure from connections.
- Replace VFD cover reusing fasteners.

#### NOTE

Repeat this step for fan 2, if applicable.

## Optional Hardwire Connections Digital Input

### NOTE

All field installation and wiring of electrical equipment must be done to meet NEC, CEC and local codes.

Be sure to use appropriately sized wire for the full load amp draw.

Once the following hardwiring is complete, please refer to the **BMS Settings** menu for details on programming the BMS to communicate with the Vektor System Control via the hardwire connections.

### Remote Enable/Disable (on/off) Switch

(Customer supplied switch; hardwire connections)

A switch can be wired to the control box to remotely enable or disable the Vektor System Control (VSC). Wiring this switch is optional; if remote enable/disable is not required, no action is required and the system can be enabled and disabled on the Programmable Logic Controller (PLC) in the control box.

Wiring remote switch:

- Connect SYON+ on the control box terminal strip to one side of the remote switch.
- Connect +24V to the other side of the remote switch.
- Connect SYON- on the control box terminal strip to COM on the terminal strip.
- See the **Digital Input Programming** menu section of this manual for details on enabling this feature.

### Remote Safety Enable/Disable (on/off) Switch

(Customer supplied switch; hardwire connections)

A safety switch can be wired to the control box to remotely enable/disable the VSC. This feature is primarily used for emergency stop buttons or duct static pressure safety switches; if the static pressure in the duct work is too high, the switch will open or close to disable the fan system. Wiring this switch is optional; if remote safety enable/disable is not required, no action is required.

Wiring remote safety switch:

- Connect SAFE+ on the control box terminal strip to one side of the remote safety switch.
- Connect +24V to the other side of the safety switch.
- Connect SAFE- on the control box terminal strip to COM on the terminal strip.
- See the **Digital Input Programming** menu section of this manual for details on enabling this feature.

### Fireman Override

(Customer supplied switch; hardwire connections)

A fireman override switch can be wired to the control box to remotely adjust the fan speed. In the event of a fire, the VSC can receive an input from the fireman override switch and force the fan system to a user adjustable setpoint between 0 and 100%. Wiring this switch is optional; if fireman override is not required, no action is required.

Fireman override switch:

- Connect FIRE+ on the control box terminal strip to one side of the fireman override switch.
- Connect FIRE- on the control box terminal strip to other side of the fireman override switch.
- See the **Digital Input Programming** menu section of this manual for details on enabling this feature.

### Alarm Output

(Hardwire connections)

If a component of the VSC triggers an alarm, a relay within the CAREL will close or open (user adjustable) a dry contact to alert the Building Management System (BMS). The alarm can be diagnosed on the CAREL PLC in the control box; BACnet™ can also be used to diagnose the issue.

Wiring alarm output:

- Connect ALRM+ on the control box terminal strip to BMS.
- Connect ALRM- on the control box terminal strip to BMS.
- See the **Digital Input Programming** menu section of this manual for details on enabling this feature.

### BACnet™

(Hardwire connections)

BACnet™ IP and BACnet™ MS/TP are both supported by the VSC.

BACnet™ IP:

- Use CAT-5 STP shielded cables
- The PLC has two Ethernet ports that are connected internally, making it easy to daisy-chain units together.
- See the **BMS Settings** menu section of this manual for additional details.

BACnet™ MS/TP:

- The J25 BMS2 connector on the PLC is used to connect the BACnet™ MS/TP.
- To improve immunity against electromagnetic interference, the serial connection cable should be a 3-wire shielded twisted pair.
- Connect the twisted pair wires to the J25 BMS2 connector - and + on the PLC to the appropriate BMS connections.

## Optional Hardwire Connections Digital Input (continued)

- The third wire of the shielded twisted cable should be used to connect the J25 BMS2 GND connection to the BMS RS485 ground reference.
- The shielding on the twisted pair 3-wire cable should only be connected to ground on one end of the cable; the green/yellow GND terminal in the VSC box is a suitable location to ground the shielding of the cable.
- See the **BMS Settings** menu section of this manual for additional details.

### NOTE

This PLC does not contain any internal terminating resistors.

Do not connect BACnet to VFD(s); all BACnet communication is transmitted through the CAREL® controller.

## Vektor System Control Menu Tree

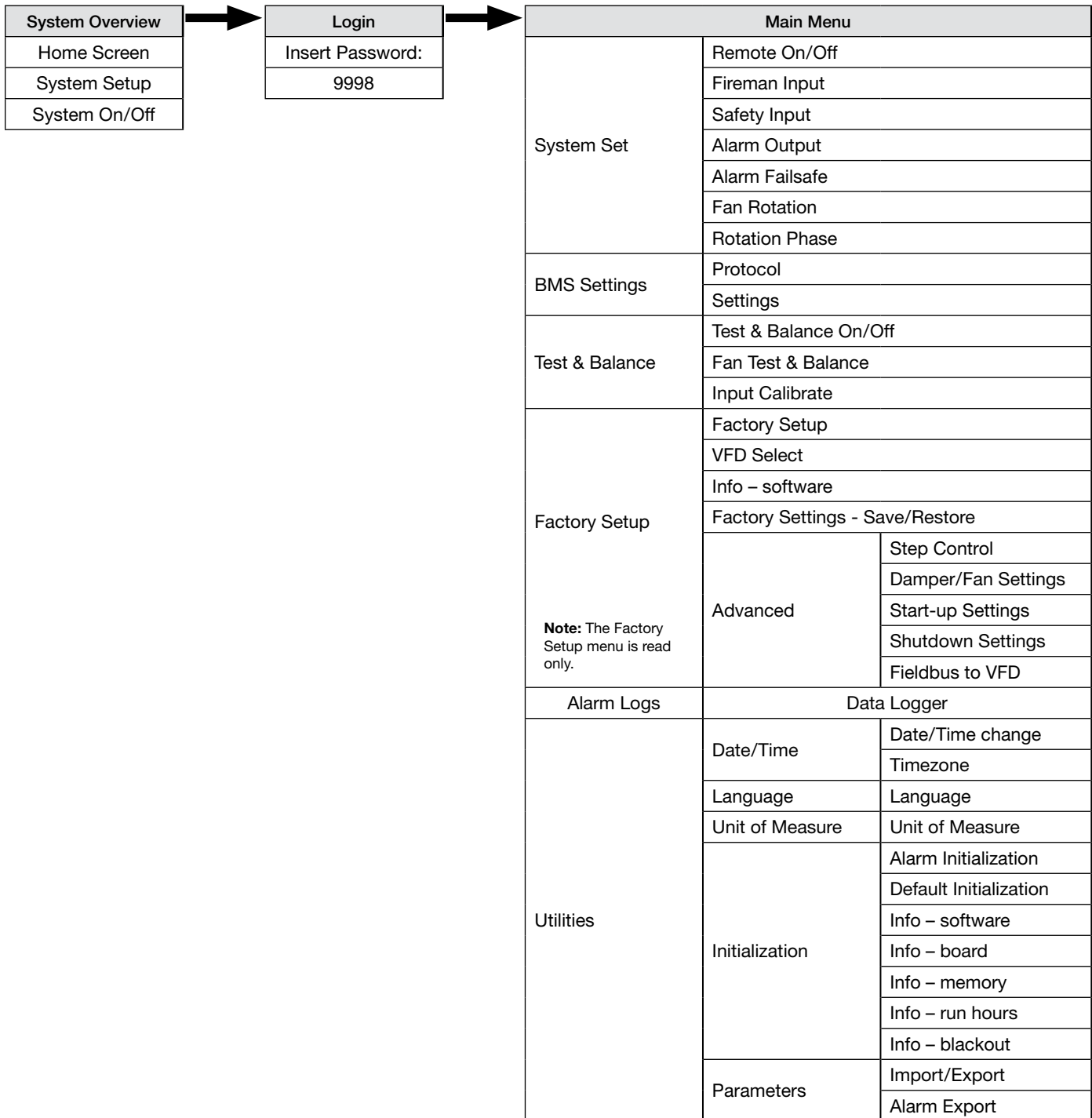

# Digital Input Programming

## Programmable Logic Controller (PLC) Introduction and Tutorial





The VSC Programmable Logic Controller (PLC) is located in the main control panel. The PLC has factory set points that can be modified to configure the system for job specific functions. The directions for the setup screens are shown in this section.

The face of the controller has six buttons, allowing the user to view unit conditions and alter parameters. The PLC is pre-programmed with easy-to-use menus.



### Operator Interface and Keypad Navigation



Keypad Navigation		
	Escape	Allows the user to exit the current menu, jumping to the Main Menu.
	Up   Down	The arrow buttons allow the user to scroll through different screens and adjust parameters.
	Alarm	Button will blink red, indicating an alarm condition. Press to review current alarms. To review previous alarms, access the DATA LOGGER through the main menu.
	Enter	A. In screens with adjustable parameters, pressing the Enter button moves the cursor from the upper left corner of the screen to the parameter. The arrow buttons can then be used to adjust the parameter. B. To move to the next parameter on the same screen, press the Enter button. C. To save the change, press the Enter button until the cursor moves back to the upper left corner of the screen.
	Program	Pressing the Program button allows the user to enter the Main Program Menu.

## Determining Parameters

### Parameter Adjustment

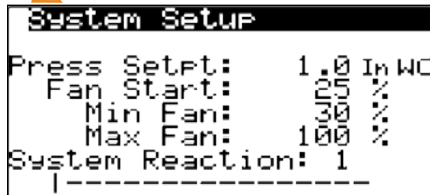

System Setup

Press Setpt: 1.0 In Wd  
Fan Start: 25 %  
Min Fan: 30 %  
Max Fan: 100 %  
System Reaction: 1

The cursor is positioned at the top left corner of the display, indicating the start of the adjustment process.

The cursor begins in the upper left corner of the display and will be blinking. Press the *Enter* button to advance the cursor down to make a change to a setting.

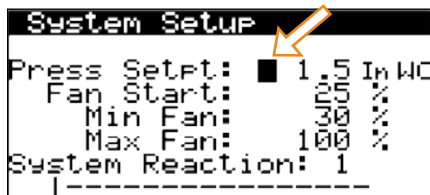

System Setup

Press Setpt: 1.5 In Wd  
Fan Start: 25 %  
Min Fan: 30 %  
Max Fan: 100 %  
System Reaction: 1

The cursor has moved to the 'Fan Start' setting, which is now highlighted with a black square.

Once the cursor has reached the desired setting to be changed, use the arrow keys to adjust the value. Press *Enter* to save the value.

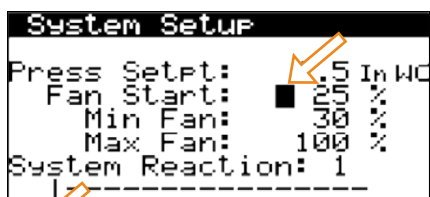

System Setup

Press Setpt: 1.5 In Wd  
Fan Start: 25 %  
Min Fan: 30 %  
Max Fan: 100 %  
System Reaction: 1

The cursor is now positioned over the numerical value '25' of the 'Fan Start' setting.

Continue to press *Enter* to advance the cursor through the remaining settings.



System Setup

Press Setpt: 1.5 In Wd  
Fan Start: 25 %  
Min Fan: 30 %  
Max Fan: 100 %  
System Reaction: 1

The cursor has returned to the top left corner of the display, indicating the end of the adjustment process.

Stop pressing *Enter* when the cursor is back in the upper left corner. If *Enter* is not pressed after making a change, the change will not be saved.

## System Overview

The controller will revert to a default main menu loop. This loop includes several screens to view the operating conditions and status of the system and fans. Scroll through the menu screens with the up and down arrows.

```
Fan Status
59% OFF

Pressure:      1.0 In WC
Press Setpt:  1.0 In WC
Bypass:        0 %
ON
```

### Home Screen

The initial menu will display the overall system status and main operating conditions. Fan speed percentage, measured pressure, pressure setpoint, bypass percentage open, and overall unit status are shown.

```
System Setup
Press Setpt:  1.0 In WC
Fan Start:    25 %
Min Fan:      30 %
Max Fan:      100 %
System Reaction: 1
|-----|
```

### System Setup

The system setup menu will display and will allow changing of values for common operational values.

Press Setpt - duct static pressure system is to monitor and maintain.

Fan Start % - provides an initial speed setting for fans when starting up.

Min Fan % - minimum fan speed. If pressure is higher than setpoint as the fans are at the minimum speed, the bypass dampers (if equipped) will begin to open.

Max Fan % - maximum allowable speed that the fan will operate at.

System Reaction - used to tune the system response to changes. 1 is slower response, 9 is a faster response.

```
System On/Off
Press ↵ to turn on

OFF 
```

### System On/Off

To turn the system and fans to ON, press the *Enter* button to change to ON.

The system will start up after a 10 second delay. Use the *Enter* button to turn the system off.

## Main Menu

The controller is equipped with several menus to help guide users with operating the system and altering parameters. The following menus can be accessed by pressing the  button. To enter the desired menu, press the enter button.

### Login

The Login menu allows access to additional menus for parameter adjustments.

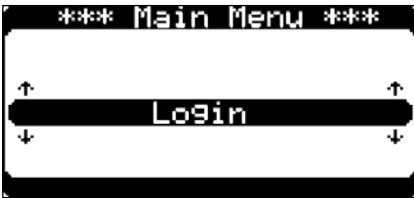

Press the  button to access the Login menu and press *Enter*.

Note: To see the menu options, one must login.





### Login

Using the *Up* and *Down* arrows and *Enter* to advance the cursor, enter the service level password of 9998. This will provide read/write access to the additional menus with the exception of the Factory Setup menu, which will be read only. Consult the factory if Factory Setup changes are required.

### System Set

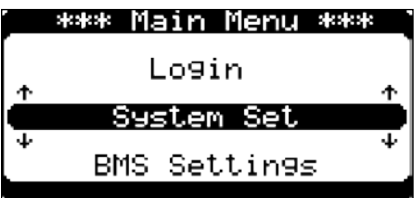
The System Set menu allows the user to configure I/O, alarms, and fan rotation.



Press the  button, login with the password 9998, and scroll to the System Set menu and press *Enter* to access it.

### Remote On/Off

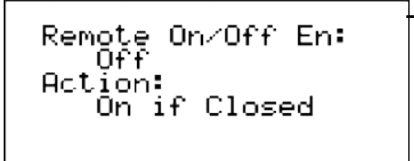

### Remote On/Off

To utilize a hardwired remote on/off switch, enable the functionality by changing Off to On via the Enter and arrow keys. Select the desired switch action.

Note: In order for the digital remote input to turn the system on, the System On/Off must be turned to On, otherwise Off by Keypad will be displayed in the main unit status line of the home screen.

On if Open = remote On when switch is open

On if Closed = remote On when switch is closed

Refer to the **Component Hardwiring** section to make wiring connection needed for the remote On/Off switch. On the terminal strip wire:

- From 24 VAC to connection on On/Off switch.
- From SYSON+ to second connection on On/Off switch
- Jumper from SYSON- to COM

### Fireman Settings

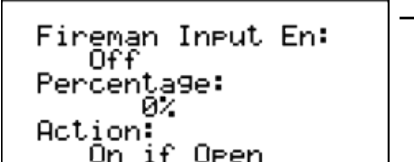

### Fireman Settings

To utilize a fireman's override switch, enable the functionality by changing OFF to On via the Enter and arrow keys. Select the desired fan speed percentage and switch action. Factory default is 0%.

On if Open = fireman override speed is active when switch is open

On if Closed = fireman override speed is active when switch is closed

Refer to the **Component Hardwiring** section to make wiring connection needed for the Fireman switch. On terminal strip wire:

- From Fire+ to connection on switch.
- From Fire- to second connection on switch



Safety Input Settings	Safety Input Settings
<pre>Safety Input En:   Off Action:   On if Open</pre>	<p>To utilize a hardwired safety switch, enable the functionality by changing Off to On via the enter and arrow keys. Select the desired switch action.</p> <p>On if Open = safety is on/active (system is off) when switch is open  On if Closed = safety is on/active (system is off) when switch is closed</p> <p>Refer to the <b>Component Hardwiring</b> section to make wiring connection needed for Safety switch. On terminal strip wire:</p> <ul style="list-style-type: none"> <li>• From 24VAC to connection on safety switch.</li> <li>• From SAFE+ to second connection on safety switch</li> <li>• Jumper from SAFE- to COM</li> </ul>

**NOTE**

It is highly recommended a static pressure safety switch be used to measure fan plenum static pressure and wired to this Safety Input to prevent accidental damage to ducts due to over pressurization.

Alarm Output Settings	Alarm Output Settings
<pre>Action:   Open If Alarm</pre>	<p>To utilize a dry contact for alarm notification, wire to ALRM- and ALRM+ on the terminal strip. Select the desired contact action when an alarm triggers.</p>

Alarm Failsafe	Alarm Failsafe
<pre>All Pressure Transducer Fail Fan Speed: 0%</pre>	<p>This screen sets the fan(s) speed in the case of a pressure transducer failure. Upon transducer failure or loss of signal, the fan will be commanded to the Alarm Failsafe percentage. Factory default is 0%.</p>

Fan Rotation	Fan Rotation
<pre>Rotation Source: Local When to Rotate: Never  Force Rotation Now: No</pre>	<p>Fan Rotation is the switching of the primary fan when operating a system with a standby fan so that equal run is achieved on both fans. Note: Fan rotation is only available when a standby fan is present.</p> <p>The fan rotation source can be set to Local or BMS.</p>

Fan Rotation	Fan Rotation
<pre>Rotation Source: Local When to Rotate: Weekly Rotate Every: 100 hr Next On Fan: LIFO Rotation Day: Any Rotation Time: 05:00AM Force Rotation Now: No</pre>	<p>When to Rotate can be set to Never, Weekly, or Daily. A rotation can be manually forced by changing Force Rotation to Yes.</p> <p>With When to Rotate set to Daily or Weekly, additional settings appear. The duration, rotation type, day, and time of the rotation can be set.</p> <p>Once the fan that is scheduled to rotate out accumulates the user adjustable rotation hours, the system will wait until the user adjustable time. If set to <i>Daily</i>, it will rotate at the time set in the controller. If set to <i>Weekly</i>, it will rotate at the time and day set in the controller.</p>

Fan Rotation	Fan Rotation
<pre>Rotation Source: BMS</pre>	<p>When rotation source is Local, the Next On Fan rotation type can be set to:</p> <ul style="list-style-type: none"> <li>• LIFO (last in, first out),</li> <li>• FIFO (first in, first out), or</li> <li>• Lowest hrs.</li> </ul> <p>With Rotation Source set to BMS, send a value of 1 to Binary Value 4, FanRotation_ForceRotate, when you want to rotate the fans. With BMS as the source for fan rotation, the BMS controls when to force rotate the fans and is not scheduled in the controller.</p>

Rotation Phase Timers		
1:	New Fan ON:	30s
2:	New Fan Ramp:	30s
3:	Old Fan Ramp:	1s
4:	Old ISO Close:	30s
Rotation Min: 30%		

### Rotation Phase

**New Fan On:** New fan is at rotation minimum fan speed for this time with isolation damper closed. After this timer expires, the new fan isolation damper is commanded open.

**New Fan Ramp:** New fan will ramp from rotation minimum fan speed for this duration while old fan maintains static pressure using PID control. At the end of this timer, PID control is transferred to the new fan and the old fan enters the old fan ramp timer.

**Old Fan Ramp:** Time for old fan to ramp down from current speed to rotation minimum fan speed.

**Old ISO Close:** This is the time the old fan continues to run after its isolation damper is commanded to close account for the time for the damper to close.

**Rotation Min:** Minimum fan speed that can occur during a fan rotation. Adjusting the Rotation Min to 20% less than the normal operating percentage will provide optimal performance.

End of Menu
-------------

### End of Menu

**BMS Settings** The BMS Setting menu is where BMS communications are configured.

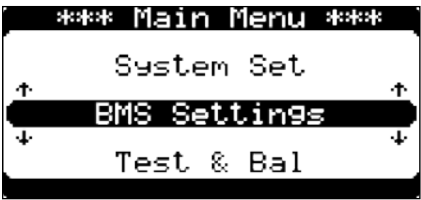

Press the **⊙** button, login with the password 9998, and scroll to the BMS Settings menu and press *Enter* to access it.



**Supervisory/BMS**

The communication protocol is selected here. Options exist for:

- BACnet™ MS/TP
- None
- BACnet™ IP

After making a change to the protocol, press *Enter* to accept the change.

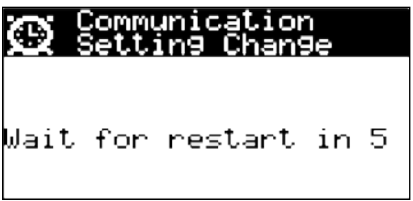

The controller will automatically restart to implement the changes. After restart, the service level password will need to be re-entered to access the menus.

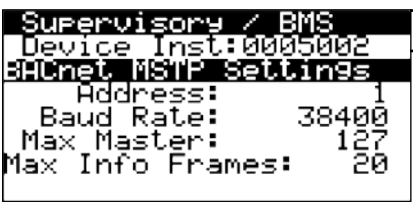

**Supervisory/BMS – BACnet™ MSTP Settings**

The Device Instance is displayed on this screen and is adjustable. Address, Baud Rate, Max Master, and Max Info Frames information is displayed here and is adjustable.  
 Note: The settings shown here are the default settings for BMS communications.

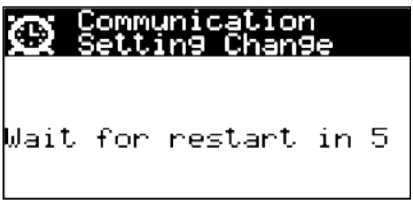

The controller will automatically restart to implement the changes. After restart, the service level password will need to be re-entered to access the menus.

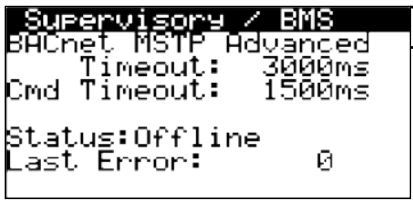

**Supervisory/BMS – Advanced BACnet™ MSTP**

Timeouts are displayed on this screen and are adjustable. Error status is displayed.

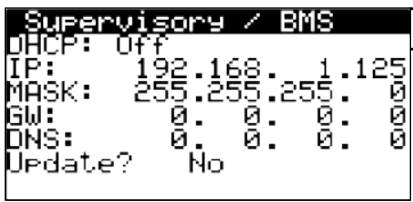

**Supervisory/BMS – BACnet™ IP Settings**

If BACnet™ IP is selected as the protocol, this screen will allow for setting of the address and subnet mask.  
 After making changes, change Update to Yes.

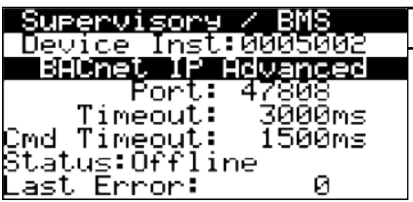

**Supervisory/BMS – BACnet™ IP Settings**

If BACnet™ IP is selected as the protocol, timeouts are displayed on this screen and are adjustable. Error status is displayed.

**Supervisory / BMS**  
BACnet IP BBMD  
Register as a  
foreign device?: NO

**Supervisory/BMS – BACnet™ IP Settings**

If BACnet™ IP is selected as the protocol, BACnet™ Broadcast Management Device is setup on this screen.

**End of Menu**

**End of Menu**



**Test & Bal** The Test & Bal menu allows for overrides for testing and transducer calibration.

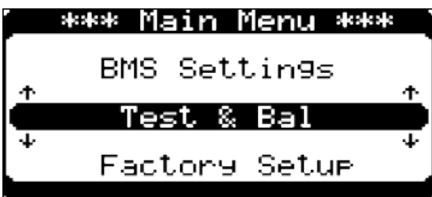

Press the  $\odot$  button, login with the password 9998, and scroll to the Test & Balance menu and press *Enter* to access it.

**NOTE**  
Running the VFD(s) in hand mode will not open the fan's isolation damper. Use the Test&Bal feature in the Carel to operate the fans.

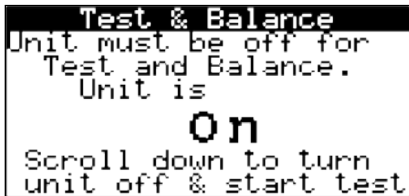

**Test & Balance**

To enter Test & Balance mode, the unit must be off. This screen will be displayed if the controller is currently ON.



To start Test and Balance mode, press *Enter* to change TEST OFF to TEST ON.

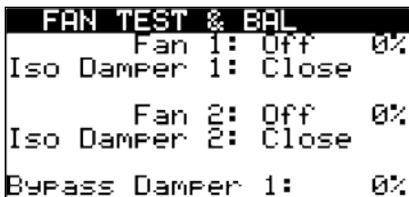

**Fan Test & Balance**

**CAUTION**  
Fan and system will operate as set in this screen regardless of duct pressure. Damage may occur if fan/system is commanded to incorrect speed or incorrect operation.

Fan operation, fan speed and damper positions can be manually overridden. Press *Enter* to advance the cursor and use the *Up* and *Down* arrows to make changes. Press *Enter* to accept the changes. Changes to command operation will occur immediately after pressing *Enter*.

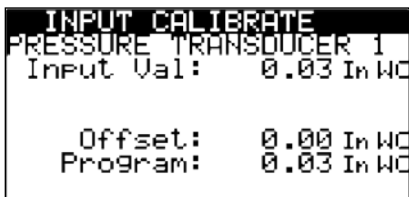

**Input Calibrate**

This screen allows for a positive or negative offset to be applied to the input value for the duct static pressure sensor to ensure accurate readings at the controller. Adding a negative offset would offset a high input value and a positive offset would offset a low input value.



**End of Menu**

## Factory Setup

The Factory Setup settings can only be viewed with the service password.

```
*** Main Menu ***
      Test & Bal
  ↑      Factory Setup      ↑
  ↓      Alarm logs        ↓
```

Press the **⊙** button, login with the password 9998, and scroll to the Factory Setup menu and press *Enter* to access it.

Note: The Factory Setup menu can only be viewed with the service level password. Consult the factory for changes to the Factory Setup.

```
Factory Setup
Number of Fans:      2
Standby Fan:        Yes
Bypass Damper:      Yes
```

## Factory Setup – Fans

This screen is used to set the number of fans in the system and to configure the system for use of a standby fan and/or bypass dampers.

```
ATTENTION!
Turn off the unit
to change unit
settings
Press ESC to back
```

Note: Unit must be off to make changes.

```
Factory Setup
Number of Fans:      2
Standby Fan:        Yes
Bypass Damper:      Yes
Settings Change
Restarting in 4
```

Note: System will automatically reboot after a change is made.

```
VFD Select
VFD:Danfoss FC 102
```

## VFD Select

This screen is used to set the VFD model that is being used for the fans.

```
ATTENTION!
Turn off the unit
to change unit
settings
Press ESC to back
```

Note: Unit must be off to make changes.

```
VFD Type
Setting Change
Wait for restart in 4
```

Note: System will automatically reboot after a change is made.

```
Info
*GREENHECK FAN CORP*
Code: USGHFeVKHQ_1
SW ver.: 1.2.004
OS ver.: 4.6.001
BOOT ver.: 4.6.002
```

## Info

This screen displays software information. The SW ver. is the software version installed in the controller.

<pre> Factory Settings Save Factory Settings: No  Restore Factory Settings? No </pre>	<p>This screen is used to save and restore factory settings</p>
<pre> Advanced Settings </pre>	<p><b>Advanced Settings</b></p> <p>The menus under the Advanced Settings set the parameters for the control of the system and should only be changed under the direction of the factory. Improper settings may result in unstable and erratic fan behavior.</p>
<pre> Step Control Settings STEP CONTROL Step Band: 1.0 Positive DB: 0.0 Negative DB: 0.0 Max Time: 2500 Min Time: 250 Max Step: 11.0 </pre>	<p><b>Step Control Settings</b></p> <p>For factory use only.</p>
<pre> Step Control Settings Step Slope: 10.0 In WC Pause Up: NO Pause Down: NO  Demand: 0.0% Demand Used: 0.0% </pre>	<p><b>Step Control Settings</b></p> <p>For factory use only.</p>
<pre> Damper/Fan Settings Startup Damper: 0% Start Fan Delay: 0s Limit Fan Delay: 15s Fan Start: 25% Hysteresis Right: 0% Hysteresis Left: 0% </pre>	<p><b>Damper/Fan Settings</b></p> <p>This screen sets the initial bypass damper position during startup, fan delays, fan start speed and hysteresis.</p> <p>Note: This screen is only displayed when the system has a bypass damper.</p>
<pre> Startup Settings Startup Mode: Isolation Damper Open AFTER Fan Starts  DELAY TIME: 10s </pre>	<p><b>Start-Up Settings</b></p> <p>This screen configures the isolation damper operation during start-up. The isolation damper can start After or When the fan starts with an adjustable delay.</p>
<pre> Shutdown Settings Shutdown Mode: Isolation Damper Close BEFORE Fan Shuts Down  DELAY TIME: 10s </pre>	<p><b>Shutdown Settings</b></p> <p>This screen configures the isolation damper operation during shutdown. The isolation damper can start Before or When the fan starts with an adjustable delay.</p>
<pre> Fieldbus to VFD Modbus RTU Settings Baud Rate: 19200 StopBits:1 Parity:None Apply Settings Now: No Address VFD1: 1 VFD2: 2 </pre>	<p><b>Fieldbus to VFD</b></p> <p>This screen configures the Modbus® communication to the VFDs.</p>

**Fieldbus to VFD**  
Modbus RTU Advanced  
Detect Interval: 10sec  
Retries: 3  
  
Polling Delay: 10ms  
Polling Time: 12647ms  
Polling Loops: 954

**Fieldbus to VFD**

This screen configures the Modbus® communication to the VFDs.

**Fieldbus to VFD**  
Modbus RTU Advanced  
Timeout: 1000ms  
Detect Timeout: 2000ms  
Command Delay: 1ms

**Fieldbus to VFD**

This screen configures the Modbus® communication to the VFDs.

**End of Menu**

**End of Menu**





## Alarm Logs

The Alarm Logs menu displays historical alarm information.

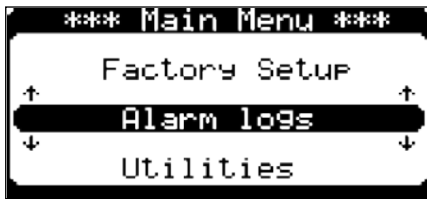

Press the **⊙** button, login with the password 9998, and scroll to the Alarm logs menu and press *Enter* to access it.

Note: After entering the menu, pushing the *Down* arrow will scroll through the most recent alarms.

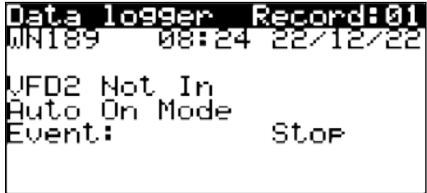

## Data Logger Recording

This screen will display the alarm number, date and time of the alarm, a verbal description of the alarm, and the resulting event impact to the system.

**Utilities** The Utilities menu allows the user to configure various controller attributes.

```
*** Main Menu ***
Alarm logs
Utilities
Logout
```

Press the **⊙** button, login with the password 9998, and scroll to the Utilities menu and press *Enter* to access it.

Note: The Utilities menu has sub-menus under it, each with their own setup screens. After entering the menu, pushing the *Down* arrow will scroll through the available sub-menus.

```
*** Utilities Menu ***
Parameters
Date/Time
Language
```

**Date/Time sub-menu**

```
Date/Time change
Format:      DD/MM/YY
Date:        28/12/22
Hour:        16:17:00
Day:         Wednesday
```

**Date/Time Change**

This screen is used to set the format, date, time and day for the controller.

```
Timezone
Time zone:
(UTC) Coordinated Univ
ersal Time
```

**Timezone**

This screen is used to set the local time zone.

```
End of Menu
```

**End of Menu**



```
*** Utilities Menu ***
  Date/Time
  ↑
  Language
  ↓
  Unit of Measure
```

**Language – sub-menu**

The language displayed on the controller can be changed in this sub-menu.

```
Language:
Language: ENGLISH
ENTER to change
ESC to confirm
```

**Language**

Use this screen to change the language displayed.

```
*** Utilities Menu ***
  Language
  ↑
  Unit of Measure
  ↓
  Initialization
```

**Unit of Measure**

This sub-menu set the unit of measure.

```
Unit of Measure
UoM zone
for this display:
                USA
```

**Unit of Measure**

Unit of measure zone for the display.

```
Unit of Measure
UoM zone
for web server:
                USA
```

**Unit of Measure**

Unit of measure zone for the web server.

```

End of Menu
```

**End of Menu**

```

*** Utilities Menu ***
  Unit of Measure
  ↑
  Initialization
  ↓
  Parameters

```

### Initialization – sub-menu

This sub-menu is used for hardware/software information and memory resets.

```

Initialization
Alarm initialization
Delete alarm logs? NO
Clear AutoReset
counters? NO
Enable buzzer? NO

```

### Initialization – Alarms

This screen allows for deletion of alarm logs, clearing auto-reset counters, and enabling a buzzer on the controller when in alarm.

```

Initialization
DEFAULT INSTALLATION
Wipe retain mem.: NO
Wipe NVRAM mem.: NO
Wipe both mem.: NO

```

### Initialization – Default Installation

This screen is used for clearing various memory within the controller.

```

Info
*GREENHECK FAN CORP*
Code: USGHFeVKHQ_1
SW ver.: 1.2.004
OS ver.: 4.6.001
BOOT ver.: 4.6.002

```

### Info

This screen displays the controller code number and software versions.

```

Info
Board type: c.PCO
Board size: Small
Core: 1
Board Temp.: 89.6F

```

### Info – Board

This screen displays the controller hardware and controller temperature.

```

Info
Ret mem writes: 114
Main task:
200ms 5.0Cycle/s

```

### Info

This screen displays the memory writes and timing.

```

Work hours
Fan1: 0h
Fan2: 0h

```

### Work Hours

This screen displays the fan run time.

```

Info
Blackout info
Current time:
22/12/22 12:07:33
PowerOff time:
21/12/22 17:18:34
Length last time off:
0Days 15Hrs 5Min

```

### Info

This screen records the last loss of power event.



<div style="border: 1px solid black; padding: 5px; text-align: center;"> <b>End of Menu</b> </div>	<b>End of Menu</b>
--	--------------------

<pre> *** Utilities Menu ***   Initialization   ↑ Parameters ↑   ↓ Date/Time ↓ </pre>	<b>Parameters – sub-menu</b> This sub-menu is used for importing or exporting information from the controller.
---	---

<pre> Unit configuration Params Import/Export Import/Export: IMPORT Memory type: INTERNAL FLASH MEMORY File name: EXPORT_00 Confirm: NO </pre>	<b>Unit Configuration – Import/Export</b> This screen is used to import/export unit configuration parameters.
--	--

<pre> Unit configuration Alarm Export Memory type: INTERNAL FLASH MEMORY File name:AL_EXPORT_00 Confirm? NO </pre>	<b>Unit Configuration – Alarm Export</b> This screen is used to export the alarm log to a USB.
--	---

<pre> Unit configuration Log Export Export to Internal is automatic, daily Export Location: INTERNAL FLASH MEMORY Confirm? NO </pre>	<b>Unit Configuration – Log Export</b> This screen is used to export the data log to a USB.
--	--

<div style="border: 1px solid black; padding: 5px; text-align: center;"> <b>End of Menu</b> </div>	<b>End of Menu</b>
--	--------------------

## System Startup and Testing

The System Startup and Testing section of this manual will provide a step-by-step procedure to set up the VFD(s) Modbus address, incoming power and fan wheel rotation direction. This system can be ordered with an ABB VFD or a Danfoss VFD. Use the instructions for your specific model VFD. Also included in this section is the setup of the bypass damper(s) and isolation damper(s). There is a check list at the end of this section that can be filled out to document the settings and proper function of the VSC components.

### Wire and Configure Optional Connection Wiring:

Prior to applying power to the Vektor System Control (VSC) components review the **Optional Hardware Connections Digital Input** section of this manual. The optional hardware connections are not required to operate the VSC; BMS is not required to run the VSC.

#### NOTE

It is highly recommended that a static pressure safety switch be installed in the plenum of the fan system, and wired to the Remote Safety Enable/Disable (on/off) Switch terminals on the terminal strip. This safety switch should open the electrical connection in the event that the static pressure is too high in the fan plenum; this will turn the fan system off prior to damaging the duct work. If the switch is installed, see the **Digital Input Programming** section of this manual for details on enabling this feature.

1. Optional Connection Wiring include:
  - Remote Enable/Disable (on/off) Switch
  - Remote Safety Enable/Disable (on/off) Switch
  - Fireman Override
  - Alarm Output
  - BACnet™
2. See **Digital Input Programming** section of this manual for details on enabling these features.

### System Startup Prechecks:

Prior to applying power to the Vektor System Control (VSC) components perform the following checks to avoid damage to the components:

Confirm the following:

1. Incoming voltage and motor nameplate data match the VFD(s) label.
2. Fan Mark on the VFD(s) and the Control Box match the Fan Mark on the fan.
3. 5 and 8 pin cables have been connected.
4. 5 and 8 pin cables are routed at least 12 inches from power cables.
5. Pressure transducer has been wired and plumbed.
6. System can be turned on safely without damage to the duct work. If the duct system is closed off completely and the fan system is turned on, the duct work may be damaged.

## VFD Setup

---

### Danfoss VFD Model:

1. Apply power to the VFD(s).
2. Turn on disconnect located on VFD(s) and/or local fan disconnect(s).
3. Complete the following steps for optimal system performance and to avoid startup issues:

#### NOTE

The fan farthest from the Damper Junction Box with the quick connect on the fan plenum is Fan 1; trace the wire connection from the fan motor to the VFD to confirm which VFD is Fan1.

Skip Modbus Address Setting for one fan systems.

### Danfoss FC102 Modbus Address Setting:

1. Press *Quick Menu* key
2. Use *Up* and *Down* arrows to display My Personal Menu
3. Press *OK* key
4. Use *Up* and *Down* arrows to display 8-31 Address
5. Press *OK* key
6. Use *Up* and *Down* arrows to set the address to 1 for Fan 1
7. Press *OK* key
8. The address is now set, press *Status* key
9. Repeat for Fan 2 with the exception that the Modbus address will be 2 for Fan 2

### Danfoss FC102 Motor and Incoming Power Settings:

1. Press *Quick Menu* key
2. Use *Up* and *Down* arrows to display My Personal Menu
3. Press *OK* key
4. Use *Up* and *Down* arrows to display the following parameters. Edit any parameters that are not correct:
  - a. 1-21 Motor Power [HP]
  - b. 1-22 Motor Voltage
  - c. 1-23 Motor Frequency
  - d. 1-25 Motor Nominal Speed
5. The VFD is now configured for the motor and incoming power, press *Status* key
6. Repeat for Fan 2

## Danfoss FC102 Automatic Motor Adaptation:

### NOTE

Running the Automatic Motor Adaptation will tune the VFD for the specific motor connected to the VFD. This can make the system more efficient, and in some cases, solve motor run issues.

1. Press *Quick Menu* key
2. Use *Up* and *Down* arrows to display My Personal Menu
3. Press *OK* key
4. Use *Up* and *Down* arrows to display 1-29 Automatic Motor Adaptation (AMA)
5. Press *OK* key
6. Use *Up* and *Down* arrows to select [1] Enable complete (AMA)
7. Press *OK* key
8. Follow the on-screen instructions. The test runs automatically and will indicate when it is complete.
9. The VFD will take several minutes to perform the AMA. The motor will not turn during AMA.
10. Some motors may be unable to run the complete AMA version of the test. If the complete AMA fails, select [2] Enable reduced AMA and run the reduced AMA.
11. The VFD is now optimized for the motor, press *Status* key.
12. Repeat for Fan 2.



**ABB VFD Model:**

1. Apply power to the VFD(s).
2. Turn on disconnect located on VFD(s) and/or local fan disconnect(s).
3. Complete the following steps for optimal system performance and to avoid start up issues:

**NOTE**

The fan farthest from the Damper Junction Box with the quick connect on the fan plenum is Fan 1; trace the wire connection from the fan motor to the VFD to confirm which VFD is Fan 1.

Skip Modbus Address Setting for one fan systems.

**ABB ACH580 Modbus Address Setting:**

1. Press Menu key.
2. Use *Up* and *Down* arrows to highlight Parameters.
3. Press *Select* key.
4. Press *Select* key to select the complete list.
5. Use *Up* and *Down* arrows to highlight 58 Embedded fieldbus.
6. Press *Select* key.
7. Use *Up* and *Down* arrows to highlight 58.03 Node address.
8. Press *Edit* key.
9. Use *Up* and *Down* arrows to set the address to 1 for Fan 1.
10. Press *Save* key.
11. Repeat for Fan 2 with the exception that the Modbus address will be 2 for Fan 2.

**ABB ACH580 Motor and Incoming Power Settings:**

1. Press Menu key.
2. Use *Up* and *Down* arrows to highlight Parameters.
3. Press *Select* key.
4. Press *Select* key to select the complete list.
5. Use *Up* and *Down* arrows to highlight 99 Motor data.
6. Press *Select* key.
7. Use *Up* and *Down* arrows to highlight 58.03 Node address.
8. Use *Up* and *Down* arrows to display the following parameters; edit any parameters that are not correct:
  - a. 99.06 Motor nominal current
  - b. 99.07 Motor nominal voltage
  - c. 99.08 Motor nominal frequency
  - d. 99.09 Motor nominal speed
  - e. 99.10 Motor nominal power
9. The VFD is now configured for the motor and incoming power. Press *Back* and *Exit* to return to the Main Menu.
10. Repeat for Fan 2.

## System Component Set:

When the system arrives, there will be factory default parameters that will need to be edited to configure the system to properly function. Perform the following steps to ensure proper function of the entire system.

1. With the fan off, remove fan wheel inspection cover. The fan rotation will be checked during this procedure.
2. Apply power to the VFD(s).
3. Turn on disconnect located on VFD(s) and/or local fan disconnect(s).
4. Press *Auto* button on VFD(s).
5. Apply power to the Control Box. Do not start the fans.
6. Complete the following steps for optimal system performance and to avoid start up issues:

## Confirm Fan Wheel Rotation Direction and Isolation Damper Function:

1. Start at the Home Screen. Press the  on the CAREL® keypad.
2. Press *Enter* key to Log in.
3. Use *Up* and *Down* arrows to change number. Use *Enter* key to cycle to the next number; enter in password: 9998.
4. Press *Enter* key.
5. Use *Up* and *Down* arrows to highlight “Test & Bal”.
6. Press *Enter* key.
7. Press *Enter* key to change TEST OFF to TEST ON.
8. Press *Down* arrow.
9. Confirm the system can be turned on safely without damage to duct work. If the duct system is closed off completely and the fan system is turned on, the duct work may be damaged.
10. Press *Enter* key multiple times to highlight Fan 1: “%”. Use *Up* and *Down* arrows to set it to 30%.

### NOTE

The fan speed must be above the Min Fan speed %. Factory default Min Fan speed is 30%.

11. Press *Enter* key multiple times to cycle back to Fan 1: OFF.
12. Use *Up* arrow to toggle it to ON. Fan 1 will begin to spin.
13. Confirm fan wheel rotation matches the rotation noted on the fan.
  - a. If fan wheel rotates in the correct direction, use *Down* arrow to turn fan OFF and proceed to the next step.
  - b. If fan is rotating backwards, use *Down* arrow to turn the fan OFF. Follow proper electrical lock out tagout procedures to ensure electrical power is off and flip flop two of the motor wires in the VFD. Repeat the above steps to ensure the fan is rotating the correct direction.
14. Press *Enter* key multiple times to cycle to Iso Damper1: “Close”.
15. Use *Up* arrow to toggle it to “Open”. Fan 1 isolation damper will begin to open.
16. Confirm that the isolation damper opened for the Fan 1 (the fan just tested for wheel rotation).
  - a. If the correct isolation damper opened, use *Down* arrow to close the isolation damper and continue to next step.
  - b. If the isolation damper opened for the opposite fan, use the *Down* arrow to close the isolation damper and then flip flop the Modbus addresses in the VFDs to assign the proper VFD to the isolation damper (see **VFD Setup – Address Setting** sections of this manual for details on Modbus addressing). Then restart at step 1 of **Confirm Fan Wheel Rotation Direction and Isolation Damper Function**.
17. Press *Enter* key to cycle to Bypass Damper 1: “%”.
18. Confirm the Bypass Damper 1: is set to 0%.
19. Visually inspect the bypass damper(s) to confirm it (they) are closed.
  - a. If the bypass damper(s) are closed, continue to next step.
  - b. If the bypass damper(s) are open, measure the DC voltage at the terminal strip between 1BYPAS and COM.
    - i. If DC voltage is less than 0.3 VDC, then rotate the reversal switch located on the bypass actuator and continue to the next step.
    - ii. If DC voltage is above 0.3 VDC, then contact factory.
20. Use *Up* and *Down* arrows to set Bypass Damper 1: to 100%.

21. Visually inspect the bypass damper(s) to confirm it (they) are open.

**NOTE**

Bypass damper can take up to 2-1/2 minutes to open from 0 - 100%.

- a. If the bypass damper(s) open to 100%, use the *Down* arrow to set Damper 1: to 0%. Press *Enter* key and continue to next step.
- b. If the bypass damper(s) are closed, measure the DC voltage at the terminal strip between 1BYPAS and COM.
  - i. If DC voltage is above 9 VDC, then trace the wires connecting the 1BYPASS and COM to the actuator.
  - ii. If DC voltage is less than 9 VDC, then contact factory.

22. Use *Up* arrow to cycle to Test & Balance screen.

23. Press *Enter* key to change TEST ON to TEST OFF.

24. Press *Escape* key multiple times to return to the Home Screen.

The above steps will ensure the system is set up correctly. It is ready for Test and Balance.

## System Setup:

System Setup can be used to fine tune the system operation to enable the fan to start at a set speed. This will allow the system to stabilize faster at start up. The fans minimum and maximum speed can also be adjusted in the System Setup menu to aid in system stabilization and minimize fan speed hunting. System Reaction setting will increase/decrease the rate at which the system reacts to changes in demand. Setting this to 1 is a slower response, 9 is a faster response. Use this to fine tune the reaction time of the system to eliminate fan hunting. Prior to adjusting these parameters, the systems minimum and maximum fan speed will need to be determined along with the most common steady state fan speed.

Recommended starting points for settings:

- Fan start % = Ten percent less than the most common steady state fan speed
- Min Fan % = Ten percent less than the minimum fan speed required to meet system demand
- Max Fan % = Ten percent more than the maximum fan speed required to meet system demand
- System Reaction = 1

1. Start at the Home Screen. Use *Up* and *Down* arrows on the CAREL® keypad, located in Control Box, to navigate to System Setup.
2. Press *Enter* key to highlight Press Setpt.
3. Use *Up* and *Down* arrows to select the desired set point.
4. Press *Enter* key to save and advance to “Fan Start %”.
5. Use *Up* and *Down* arrows to select the desired set point.
6. Press *Enter* key to save and advance to “Min Fan %”.
7. Use *Up* and *Down* arrows to select the desired set point.
8. Press *Enter* key to save and advance to “Max Fan %”.
9. Use *Up* and *Down* arrows to select the desired set point.
10. Press *Enter* key to save and advance to “System Reaction”.
11. Use *Up* and *Down* arrows to select the desired set point. 1 is slowest, 9 is fastest.
12. Press *Enter* key to save and return the cursor to top of screen.
13. Press *Escape* key to return to the Home Screen.

## Building Management System (BMS) Communication Protocol Setup:

BACnet IP and BACnet MS/TP are supported by the Vektor System Control.

### NOTE

Fans must be off to adjust BMS communication protocols. As soon as a BMS variable is edited, the controller will begin to count down from 5 seconds. Selecting and editing another BMS parameter will restart the timer. Once the last parameter has been adjusted and 5 seconds has elapsed, the controller will automatically restart.

1. Start at the Home Screen. Press the  on the CAREL® keypad.
2. Press *Enter* key to Log in.
3. Use *Up* and *Down* arrows to change the number. Use *Enter* key to cycle to the next number; enter in the password: 9998.
4. Press *Enter* key.
5. Use *Up* and *Down* arrows to highlight “BMS Settings”.
6. Press *Enter* key.
7. Press *Enter* key to edit the “Protocol Type”.
8. Use *Up* and *Down* arrows to set desired protocol type.
9. Press *Enter* key. The controller will start a 5 second countdown to automatically restart.
10. Use *Up* and *Down* arrows and *Enter* key to access and edit the parameters required to configure the BMS

# BACnet™ Objects

The following objects are available through BACnet™.

Type	Instance	Name	Access	Parameter Notes [Units]
Binary Value	1	OnOffUnitMng.BmsOnOff_Enabled (Binary_Value:1)	Read/Write	Disable/Enable – If enabled, the BMS On/Off variable (BV2) must be ON for the unit to start.
	2	OnOffUnitMng.BmsOnOff (Binary_Value:2)	Read/Write	Unit On/Off by BMS
Analog Value	102	Setpoint_SP1 (Analog_Value:102)	Read/Write	Static Pressure Setpoint 1 [in w.c.]
Binary Value	4	FanRotation_ForceRotate (Binary_Value:4)	Read/Write	Force fan rotation - used by BMS for rotating primary fan
Analog Value	5	System_Reaction_Adjust_REAL (Analog_Value:5)	Read/Write	System reaction - changes fan and damper response time
	13	FanSpeed_Fireman (Analog_Value:13)	Read/Write	User Defined Speed of Fan When Fireman's Override is Enabled [0-100%]
	14	FanSpeed_Pressure_AllAlarm (Analog_Value:14)	Read/Write	User Defined Speed of Fan When All Pressure Transducers are in Alarm [0-100%]
Binary Value	101	Pressure_Source_IO_BMS[1] (Binary_Value:101)	Read/Write	Set true if transducer value is from BMS
Analog Value	101	Pressure1_BMS (Analog_Value:101)	Read/Write	Pressure 1 measurement from BMS [0-15 IN H2O] – BV101 must be set to 1 for this pressure to be used for pressure 1 rather than the analog input. [in w.c.]
Analog Input	1	Pressure1_AIN.Val (Analog_Input:1)	Read Only	Static Pressure 1 [IN H2O]
	7	BypassDamperCmd1_AOUT.Val (Analog_Input:7)	Read Only	Bypass Damper 1 Position [0-100%]
	9	FanModCmd1_AOUT.Val (Analog_Input:9)	Read Only	Fan 1 Speed [0-100%]
	10	FanModCmd2_AOUT.Val (Analog_Input:10)	Read Only	Fan 2 Speed [0-100%]
	101	Fan_Msk[1].Power_KW (Analog_Input:101)	Read Only	Fan 1 Power [KW]
	102	Fan_Msk[1].Power_Hp (Analog_Input:102)	Read Only	Fan 1 Power [Hp]
	103	Fan_Msk[1].MotorVolt (Analog_Input:103)	Read Only	Fan 1 Motor Voltage [V]
	104	Fan_Msk[1].MotorCurrent (Analog_Input:104)	Read Only	Fan 1 Motor Current [A]
	105	Fan_Msk[1].Freq (Analog_Input:105)	Read Only	Fan 1 Frequency [HZ]
	107	Fan_Msk[1].Speed_RPM (Analog_Input:107)	Read Only	Fan 1 Motor Speed [RPM]
	108	Fan_Msk[1].Torque_Nm (Analog_Input:108)	Read Only	Fan 1 Torque [Nm]
	110	Fan_Msk[1].DCLink_Volt (Analog_Input:110)	Read Only	VFD 1 DC Link Voltage [V]
	114	Fan_Msk[1].ControllerCardTemp (Analog_Input:114)	Read Only	VFD 1 Controller Card Temp [C]
	115	Fan_Msk[1].Power_kWh_Counter (Analog_Input:115)	Read Only	VFD 1 Power kWh Counter
	116	Fan_Msk[1].Speed_Pct (Analog_Input:116)	Read Only	VFD 1 Speed Percentage
201	Fan_Msk[2].Power_KW (Analog_Input:201)	Read Only	Fan 2 Power [KW]	

AnalogInput	202	Fan_Msk[2].Power_Hp (Analog_Input:202)	Read Only	Fan 2 Power [Hp]
	203	Fan_Msk[2].MotorVolt (Analog_Input:203)	Read Only	Fan 2 Motor Voltage [V]
	204	Fan_Msk[2].MotorCurrent (Analog_Input:204)	Read Only	VFD 1 DC Link Voltage [V]
	205	Fan_Msk[2].Freq (Analog_Input:205)	Read Only	VFD 1 Heatsink Temp [C]
	207	Fan_Msk[2].Speed_RPM (Analog_Input:207)	Read Only	VFD 1 Inv Nom Max [A]
	208	Fan_Msk[2].Torque_Nm (Analog_Input:208)	Read Only	VFD 1 Inv Max Current [A]
	210	Fan_Msk[2].DCLink_Volt (Analog_Input:210)	Read Only	VFD 1 Controller Card Temp [C]
	214	Fan_Msk[2].ControllerCardTemp (Analog_Input:214)	Read Only	Fan 2 Power [KW]
	215	Fan_Msk[2].Power_kWh_Counter (Analog_Input:215)	Read Only	Fan 2 Power [Hp]
	216	Fan_Msk[2].Speed_Pct (Analog_Input:216)	Read Only	VFD 2 Speed Percentage
BinaryInput	502	AI_Prb_Pressure1.Active (Binary_Input:502)	Read Only	1 = pressure transducer alarm, operating at failsafe speed, 0 = pressure transducer is ok
	508	AI_Safety_DIN.Active (Binary_Input:508)	Read Only	1 = safety switch is active (system is off), 0 = ok.
	510	AI_VFD1_Offline.Active (Binary_Input:510)	Read Only	1 = VFD1 is offline, 0 = VFD1 is online
	511	AI_VFD2_Offline.Active (Binary_Input:511)	Read Only	1 = VFD2 is offline, 0 = VFD2 is online
AnalogValue	0	FanRotation_Method_REAL (Analog_Value:0)	Read Only	1=FIFO, 2=LIFO, 3=Lowest hrs
	1	Num_Fans_REAL (Analog_Value:1)	Read Only	Number of fans in system
	2	Num_StandbyFan_REAL (Analog_Value:2)	Read Only	1 = standby fan present, 0 = no standby fan
	3	Num_BypassDamper_REAL (Analog_Value:3)	Read Only	1 = bypass damper present, 0 = no bypass damper
	100	SwVer_REAL	Read Only	Software version
	103	RunHours_Act_REAL[1] (Analog_Value:103)	Read Only	Fan1 run hours
	203	RunHours_Act_REAL[2] (Analog_Value:203)	Read Only	Fan2 run hours

MultiStateInput	1	UnitStatus (Multi_State_Input:1)	Read Only	1 = On
				2 = Off by Alarm
				3 = Off by BMS
				4 = Off by Schedule
				5 = Off by Keypad
				6 = Fan Rotation
				7 = Off by Dig Input
				8 = Off by Safety Input
				9 = Fireman Override
				10 = In Failsafe Mode
				11 = On by Test Balance
				12 = Off by VFD Alarm
MultiStateInput	101	FanStateProg[1] (Multi_State_Input:101)	Read Only	1 = Off
				2 = Start
				3 = Rotating In – At minimum speed
				4 = Rotating In – Ramp up
				5 = Running
	201	FanStateProg[2] (Multi_State_Input:201)	Read Only	6 = Rotating Out – Ramp down
				7 = Rotating Out – At minimum speed
				8 = Shutdown
				9 = Alarm
				10 = Offline



# Troubleshooting

## WARNING

Before taking any corrective action, make certain unit is not capable of operation during repairs.

## AVERTISSEMENT

Avant d'entreprendre toute action corrective, s'assurer que l'appareil ne pourra pas fonctionner durant les réparations.

Symptom	Cause	Corrective Action
Display on CAREL controller is not on	No power	Check that control box is wired and upstream disconnect or breaker is on.
		Verify that control box transformer breaker is not tripped; this is located on the transformer under the transformer cover. Prior to resetting, verify the transformer is wired correctly
		Verify that orange J1 plug is seated firmly into CAREL controller.
		Verify that orange J1 plug has 24V AC voltage present.
VFD Offline	Display ribbon cable loose	If the CAREL has power at the J1 plug and the digital display on the bottom of the CAREL is illuminated, the ribbon cables behind the display may be loose. Use a small, flat screwdriver to pry the display from the PLC body. Inspect that both ribbon cables behind the display are correctly seated.
	No Power to VFD	Check that VFD is wired and upstream disconnect or breaker is on. Verify VFD disconnect is on.
	5 pin cable not connected	If the VFD is OFF or in Hand mode, it will not communicate with the control box. Verify the VFD is in Auto mode.
	VFD is not in Auto mode	If the VFD is Off or in Hand mode, it will not communicate with the control box. Verify the VFD is in Auto mode.
	Incorrect VFD addressing	Verify that the correct VFD Modbus® address is entered into each VFD. Addresses should be 1 for the VFD connected to fan 1 and 2 for the VFD connected to fan 2. Fan 1 is the fan closest to the 8 pin quick connect box on the plenum. If the addresses are the same neither VFD will communicate with the control box.
Pressure reading remains at 0.0 on the CAREL display with fan running	5 pin cable is too close to high power cables	Confirm that the 5 pin cable from the VFD to the control box is at least 12 inches from any incoming power or motor power. High voltage will interfere with Modbus® communication and cause intermittent VFD Offline alarms.
	Fan Pressure transducer is not wired	Wire transducer.
	Pressure transducer is wired incorrectly.	Correct wiring terminations. If pressure transducer is wired correctly 24VAC voltage should be present between terminals VAC and COM. The pressure transducer will output a 0-10VDC signal to the control box with a linear relationship to the pressure range of the pressure transducer setting.
Pressure	Pressure transducer tubing is not connected to duct	Connect transducer tubing to static pressure tap.
	Pressure transducer tubing is not connected to the correct pressure port on the bottom of the pressure transducer	Connect transducer tubing to correct port.
Pressure reading showing with fans off or incorrect pressure being displayed	Controller out of calibration	Calibrate transducers with offset in Test & Balance menu to calibrate the input.

Symptom	Cause	Corrective Action
Isolation damper does not open	8 pin cable not connected	Connect 8 pin cable from plenum to control box.
Bypass damper does not open	8 pin cable not connected	Connect 8 pin cable from plenum to control box.
Fan is hunting	System response too fast or slow Need to follow System Fine Tuning process outlined in this IOM	On system setup screen of controller, adjust the System Reaction. Increase value for faster response or decrease the value to reduce the system response. See <b>System Fine Tuning</b> section of this IOM.
BMS will not communicate with controller	Incorrect addressing	Check MSTP addressing or IP settings.
	Missing wiring	Verify MSTP wiring to J25 plug or IP Ethernet cable to either Ethernet ports on the controller.
Isolation damper is not opening  Fans not creating correct pressure or low airflow	Isolation damper is not opening	Confirm the isolation damper for the fan that is operating is open. If the isolation damper is not open, confirm the correct VFD is wired and addressed to that fan; if a nonoperating fan has the isolation damper open, then the VFD Modbus® address might need to be adjusted in the VFDs to synchronize the fan with the correct isolation damper position. Fan 1 is the fan closest to the 8 pin quick connect box on the plenum. The VFD with the Modbus® address of 1 controls fan 1 and the VFD with Modbus® address 2 controls fan 2.
	Isolation damper is not opening	After confirming that the VFD wiring and Modbus® address corresponds to the correct isolation damper measure the AC voltage between terminals ISOL1 and COM for fan 1 or ISOL2 and COM for fan 2 on the terminal strip located in the control box. If no voltage is present, contact factory. If 24VAC is present, there may be an issue with the 8 pin cable connecting the control box to the plenum or wiring in the quick connect box.  Please see the quick connect box wiring diagram located in the Component Hardwiring section in this IOM. Confirm the wire connections in the quick connect box are correct. Measure voltage between terminals ISOL1 and COM for fan 1 or ISOL2 and COM for fan 2. If 24 VAC is present, check voltage at actuator. If no voltage, then replace the 8 pin cable with a known good cable.
	Bypass damper is open	Confirm bypass damper is closed. Confirm 8 pin cable between control box and plenum is connected. If bypass damper is open and the 8 pin cable is connected, look at the display to see if the bypass position is 0%. If the CAREL displays 0%, then measure the DC voltage between 1BYPAS and COM or 2BYPAS and COM on the terminal strip located in the control box. 1.8 - 2.3VDC will be present if the CAREL displays 0% Bypass. If it is outside that range, contact factory.
	Fan is rotating backwards	Verify the fan rotation and correct if necessary.
	Excessive duct leakage.	Seal duct work.
	Max fan speed percentage is too low.	Increase max fan speed percentage.

# Control Settings Reference

Unit Model Number \_\_\_\_\_  
Unit Serial Number \_\_\_\_\_  
Sales Order Number \_\_\_\_\_

## System Setup Settings

Pressure Setpoint \_\_\_\_\_ in w.c.  
Fan Start % \_\_\_\_\_ %  
Min Fan % \_\_\_\_\_ %  
Max Fan % \_\_\_\_\_ %  
System Reaction \_\_\_\_\_

## System Set

Remote On/Off Enabled:  Off  On  
Action:  On  Off if Closed  
Fireman Input Enabled:  Off  On  
Action:  On  Off if Closed  
Fireman Input % \_\_\_\_\_ %  
Safety Input Enabled:  Off  On  
Action:  On  Off if Closed  
Alarm Output:  
Action:  On  Off if Alarm  
Alarm FailSafe % \_\_\_\_\_ %

## Fan Rotation

Rotation Source \_\_\_\_\_  
When to Rotate \_\_\_\_\_  
Rotate Every \_\_\_\_\_  
Next On Fan \_\_\_\_\_  
Rotation Day \_\_\_\_\_  
Rotation Time \_\_\_\_\_

## Rotation Phase

New Fan ON \_\_\_\_\_ seconds  
New Fan Ramp \_\_\_\_\_ seconds  
Old Fan Ramp \_\_\_\_\_ seconds  
Old Iso Close \_\_\_\_\_ seconds  
Rotation Min \_\_\_\_\_ %

## BMS Settings

BMS Protocol

- BACnet™ MS/TP  
 BACnet™ IP  
 None

## BACnet™ MS/TP Settings

Device Instance \_\_\_\_\_  
Address \_\_\_\_\_  
Baud Rate \_\_\_\_\_  
Max Master \_\_\_\_\_  
Max Info Frames \_\_\_\_\_  
Timeout \_\_\_\_\_ ms  
Cmd Timeout \_\_\_\_\_ ms

## BACnet™ IP Settings

DHCP:  Off  On  
IP \_\_\_\_\_ - \_\_\_\_\_ - \_\_\_\_\_ - \_\_\_\_\_  
Mask \_\_\_\_\_ - \_\_\_\_\_ - \_\_\_\_\_ - \_\_\_\_\_  
GW \_\_\_\_\_ - \_\_\_\_\_ - \_\_\_\_\_ - \_\_\_\_\_  
DNS \_\_\_\_\_ - \_\_\_\_\_ - \_\_\_\_\_ - \_\_\_\_\_  
Device Instance \_\_\_\_\_  
Port \_\_\_\_\_  
Timeout \_\_\_\_\_ ms  
Cmd Timeout \_\_\_\_\_ ms

Foreign Device:  No  Yes

## Our Commitment

---

*As a result of our commitment to continuous improvement, Greenheck reserves the right to change specifications without notice.*

Product warranties can be found online at [Greenheck.com](http://Greenheck.com), either on the specific product page or in the literature section of the website at [Greenheck.com/Resources/Library/Literature](http://Greenheck.com/Resources/Library/Literature).

