

R7824, R7847, R7848, R7849, R7861, R7886 Amplifiers for 7800 SERIES Relay Modules

PRODUCT DATA



FEATURES

- Flame failure response time of 0.8 or 1 second; or 2.0 or 3.0 seconds, depending on the amplifier and relay module selected. See Table 1.
- Plug-in to 7800 SERIES Relay Module through printed circuit board edge connector keyed for proper orientation.
- Flame signal test jacks measure amplifier flame signal voltage.
- 0.0 to 5.0 Vdc Flame signal strength reading range.
- Color coded label identifies flame detection type:
 Green—rectification. Red—infrared.
 Purple—ultraviolet. Blue—pulsed rectification.
- R7847B, R7848B, R7849B Dynamic Ampli-Check® circuitry tests all flame amplifier components 12 times per minute. The 7800 SERIES Relay Module locks out on safety shutdown with amplifier failure.
- R7824C and R7847C Dynamic Self-Check Rectification Amplifier, R7861 Self-Check Ultraviolet Flame Amplifier and R7886A Dynamic Self-Check Ultraviolet Amplifier test the detectors and all electronic components in the flame detection system 12 times per minute. The 7800 SERIES Relay Module locks out on safety shutdown with flame detection system failure.

NOTE: R7824C, Series 2 or greater, and R7847C, Series 4 or greater, pulse shutter when signal of 1.5 Vac is sensed.

APPLICATION

The R7824C Rectification Flame Amplifier is a solid state plug-in amplifier that responds to a rectified signal from a C7024E,F Self-Check Ultraviolet Flame Detector to indicate the presence of flame when used with an RM7824 Relay Module.

The R7847A,B Rectification Flame Amplifiers are solid state plug-in amplifiers that respond to a rectified signal from a rectification type flame detector to indicate the presence of flame when used with 7800 SERIES Relay Modules.

The R7847C Self-Check Rectification Flame Amplifier is a solid state plug-in amplifier that responds to a rectified signal from a C7012E,F Self-Check Ultraviolet Flame Detector to indicate the presence of flame when used with 7800 SERIES Relay Modules. This is not European Community (CE) approved for EC7810, EC7820, EC/RM7830 or EC/RM7850 Relay Modules.

The R7848A,B Infrared Flame Amplifiers are solid state plug-in amplifiers that respond to an infrared signal from a C7015 Infrared Flame Detector to indicate the presence of flame when used with 7800 SERIES Relay Modules.

The R7849A,B Ultraviolet Flame Amplifiers are solid state plug-in amplifiers that respond to an ultraviolet signal from a C7027, C7035 or C7044 Ultraviolet Flame Detector to indicate the presence of flame when used with 7800 SERIES Relay Modules.

The R7861A Self-Check Ultraviolet Flame Amplifier is a solid state plug-in amplifier that responds to an ultraviolet signal from a C7061 Self-Check Ultraviolet Flame Detector to indicate the presence of flame when used with 7800 SERIES Relay Modules.

The R7886A Dynamic Self-Check Ultraviolet Amplifier is a solid state plug-in amplifier that responds to a pulsed direct current signal from a C7076A,C Ultraviolet Flame Detector with adjustable sensitivity to indicate the presence of flame when used with 7800 SERIES Relay Modules.

Contents

Application	1
Features	1
Specifications	2
Ordering Information	2
Installation	4
Checkout	6



SPECIFICATIONS

Models:

Flame Detection Systems (see Table 2):

Rectification:

R7824C for use with C7024E,F Solid State Ultraviolet Detectors.

R7847A for use with flame rods, rectifying photocells or C7012A,C Solid State Ultraviolet Detectors.

R7847B for use with flame rods, rectifying photocells or C7012A,C Solid State Ultraviolet Detectors.

R7847C for use with C7012E,F Solid State Ultraviolet Detectors.

Infrared:

R7848A for use with C7015 Infrared (lead sulfide) Detector.

R7848B for use with C7015 Infrared (lead sulfide) Detector.

Ultraviolet:

R7849A for use with C7027/C7035/C7044 Minipeeper Ultraviolet Detectors.

R7849B for use with C7027/C7035/C7044 Minipeeper Ultraviolet Detectors.

R7861A for use with C7061A Ultraviolet Detector.

R7886A for use with C7076A,D Ultraviolet Detectors with adjustable sensitivity.

Flame Failure Response Time :

See Table 1.

Table 1. Relay Module Flame Failure Response Time (FFRT).

Relay Module	Flame Failure Response Time (FFRT)	
	0.8 or 1.0 seconds	2.0 or 3.0 seconds
EC7810, EC7820, EC/RM7830, EC/RM7850	1.0	2.0
RM/EC7823, RM/EC7885, RM/EC7890, RM/EC7895, RM7896, RM7888, RM7838, RM7800, RM7840	0.8	3.0
RM7824	N/A	3.0

Flame Signal (Volts dc):

Minimum Acceptable: 1.25 Vdc.

Flame Signal Voltage Range (displayed on Keyboard Display Module or measured with a 1M ohm/volt meter plugged into amplifier test jacks): 0.0 to 5.0 Vdc.

Environmental Ratings:

Ambient Temperature:

Operating: -40°F to 140°F (-40°C to 60°C).

Storage: -40°F to 150°F (-40°C to 65°C).

Humidity: Operating 85% rh continuous, noncondensing.

Vibration: Continuous 0.5G environment.

Dimensions:

See Fig. 1.

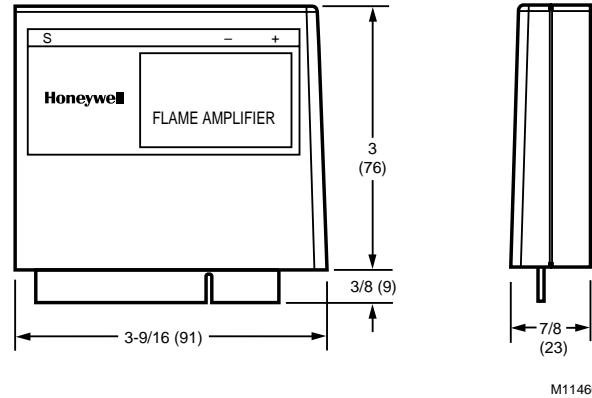

Fig. 1. Flame amplifier dimensions in in. (mm).

Weight:

2.5 oz (71g), unpacked.

Approvals:

Underwriters Laboratories Inc. Listed: File no. MP268, Guide no. MCCZZ: R7847A, R7847B, R7847C, R7861A, R7886A, R7848A, R7848B, R7849A, R7849B.

Underwriters Laboratories Inc. Component Recognized: File no. MP268, Guide no. MCCZZ: R7824C.

Canadian Standards Association Certified: LR95329-3.

Factory Mutual Approved: Report J.I.1V9A0.AF.

Industrial Risk Insurers: Acceptable.

NOTE: EN298 Approved: When these amplifiers are used with an EC7810, EC7820, EC/RM7830, or EC/RM7850 Relay Module.

Accessories:

Flame Simulators:

Rectification: 123514A.

Ultraviolet: 203659.

Flame Detectors (ordered separately): select from Table 2.

ORDERING INFORMATION

When purchasing replacement and modernization products from your TRADELINE® wholesaler or distributor, refer to the TRADELINE® Catalog or price sheets for complete ordering number.

If you have additional questions, need further information, or would like to comment on our products or services, please write or phone:

1. Your local Home and Building Control Sales Office (check white pages of your phone directory).
2. Home and Building Control Customer Logistics
Honeywell Inc., 1885 Douglas Drive North
Minneapolis, Minnesota 55422-4386 (612) 951-1000

In Canada—Honeywell Limited/Honeywell Limitée, 155 Gordon Baker Road, North York, Ontario M2H 3N7.

International Sales and Service Offices in all principal cities of the world. Manufacturing in Australia, Canada, Finland, France, Germany, Japan, Mexico, Netherlands, Spain, Taiwan, United Kingdom, U.S.A.

Table 2. Flame Detection Systems.

Plug-in Flame Signal Amplifiers				Applicable Flame Detectors			
Type	Color	Self-Checking	Model	Flame Failure Response Time (sec) ^a	Fuel	Type	Models
Rectification	Green	Dymanic Self-Check	R7824C ^{b,c, i}	3	Gas, oil, coal	Ultraviolet (Purple Peeper®)	C7024E,F
		No	R7847A ^h	0.8/1 or 2/3	Gas	Rectifying Flame Rod Holders ^j	C7004, C7007, C7011 Complete Assemblies: C7008, C7009, Q179
		No	R7847A ^h	0.8/1 or 2/3	Oil	Rectifying Photocell	C7003, C7010, C7013, C7014 ^d
		No	R7847A ^h	2/3	Gas, oil, coal	Ultraviolet (Purple Peeper®)	C7012A,C.
		Dynamic Ampli-Check®	R7847B ^{e,h}	0.8/1 or 2/3	Gas	Rectifying Flame Rod Holders ^b	C7004, C7007, C7011 Complete Assemblies: C7008, C7009, Q179
		Dynamic Ampli-Check®	R7847B ^{e,h}	0.8/1 or 2/3	Oil	Rectifying Photocell	C7003, C7010, C7013, C7014 ^d
		Dynamic Ampli-Check®	R7847B ^{e,h}	2/3	Gas, oil, coal	Ultraviolet (Purple Peeper®)	C7012A,C
		Dynamic Self-Check	R7847C ^{c,f, i}	2/3	Gas, oil, coal	Ultraviolet (Purple Peeper®)	C7012E,F
Infrared	Red	No	R7848A	2/3	Gas, oil, coal	Infrared (Lead Sulfide)	C7015
		Dynamic Ampli-Check®	R7848B ^e	3 sec	Gas, oil, coal	Infrared (Lead Sulfide)	C7015
Ultraviolet	Purple	No	R7849A	0.8/1 or 2/3	Gas, oil	Ultraviolet (Minipeeper)	C7027, C7035, C7044 ⁹
		Dynamic Ampli-Check®	R7849B ^d	0.8/1 or 2/3	Gas, oil	Ultraviolet (Minipeeper)	C7027, C7035, C7044 ⁹
		Dynamic Self-Check	R7861A ^{c,f}	0.8/1 or 2/3	Gas, oil, coal	Ultraviolet	C7061
	Blue	Dynamic Self-Check	R7886A ^{c,f}	2/3	Gas, oil, coal	Ultraviolet (Adjustable Sensitivity)	C7076

^a Flame Failure Response Time (FFRT) depends on selection of amplifier and 7800 SERIES Relay Module.

^b R7824C is used only with the 24 Vdc RM7824 Relay Module and C7024E,F Flame Detectors.

^c Circuitry tests all electronic components in flame detection system (amplifier and detector) 12 times a minute during burner operation and shuts down burner if detection system fails.

^d Use only Honeywell part no. 38316 Photocell.

^e Circuitry tests flame signal amplifier 12 times a minute during burner operation and shuts down burner if amplifier fails.

^f 200/220/240 Vac applications require a 120 Vac, 10 VA minimum stepdown transformer (not provided) to drive the shutter. Applies to R7847C series 3 or greater; R7886A series 2 or greater; R7861 series 1 or greater. Fig. 2 shows flame detector wiring.

⁹ Use C7027, C7035 and C7044 Flame Detectors only on burners that cycle on-off at least once every twenty-four hours. Use C7012E,F Flame Detector with R7847C Amplifier, C7061A Ultraviolet Detector with R7861A Amplifier or C7076A Flame Detector with R7886A Amplifier as ultraviolet flame detection system for appliances with burners that remain on continuously for twenty-four hours or longer.

^h R7847A,B Amplifiers with 0.8/1 second FFRT should not be used with C7012A,C Solid State Ultraviolet Detectors.

ⁱ R7824C Series 2 and greater and R7847C Series 4 and greater check flame detector system when flame reaches 1.5 Vdc or at 4.5 seconds, whichever occurs first.

^j Order flame rod separately; see flame detector Instructions for holder.

CAUTION

Equipment Damage Hazard.
Incorrect combination of relay module, amplifier and flame detector can cause equipment damage.
In infrared applications (C7015 Infrared Flame Detector and R7848 Amplifier) using the RM7890 Relay Module with software revision 4004 or less requires a ten-second delay to start sequence. This applies only to the initial powering of the RM7890.

INSTALLATION

When Installing this Product...

1. Read these instructions carefully. Failure to follow them could damage the product or cause a hazardous condition.
2. Check the ratings given in the instructions and on the product to make sure the product is suitable for your application.
3. Installer must be a trained, experienced, flame safeguard control technician.
4. After installation is complete, check out the product operation as provided in these instructions.

WARNING

Electric Shock Hazard.
Can cause electrical shock, serious injury or death.
Disconnect the power supply before beginning installation. More than one power supply disconnection can be involved.

IMPORTANT

1. *Wiring must comply with all applicable codes, ordinances and regulations.*
2. *Wiring (where required) must comply with NEC Class 1 (Line Voltage) wiring.*
3. *Perform all required checkout tests after installation is complete.*

CAUTION

Equipment Damage Hazard.
Can cause equipment damage.
Disconnect 7800 SERIES Relay Module power before removing amplifier.

Installing Plug-In Flame Signal Amplifier (Fig. 2)

WARNING

Electric Shock Hazard.
Can cause electrical shock, serious injury or death.
Disconnect the power supply before beginning installation. More than one power supply disconnection can be involved.

1. Align the amplifier circuit board edge connector with the keyed receptacle on the 7800 SERIES Relay Module. Be sure the amplifier nameplate faces away from the Relay Module.
2. Push in the amplifier until the circuit board is fully inserted into the receptacle and then push the amplifier toward the 7800 SERIES Relay Module retaining clasp.
3. Be sure the amplifier is firmly in place.
4. Perform all required checkout tests.

Installing Flame Detector

NOTE: Table 2 lists flame detection systems available for use with 7800 SERIES Relay Modules. Be sure to use the correct combination of amplifier and flame detector.

Proper flame detector installation is the basis of a safe and reliable flame safeguard installation. Refer to the Instructions packed with the flame detector and the equipment manufacturer instructions.

Keep the flame signal leadwires as short as possible from the flame detector to the wiring subbase. Capacitance increases with leadwire length, reducing the signal strength. The maximum permissible leadwire length depends on the type of flame detector, leadwire and conduit. However, the ultimate limiting factor for the flame detector leadwire is the flame signal; see Table 3 in the Checkout section.



Fig. 2. Installing flame signal amplifier.

Wiring

CAUTION

Electrical Shock Hazard.
Can cause electrical shock or equipment damage.
Disconnect power supply before beginning installation. More than one disconnection can be involved.

1. Remove the 7800 SERIES Relay Module from the wiring subbase.
2. Refer to Fig. 3 for proper flame detector wiring.
3. Disconnect power supply before making wiring connections to prevent electrical shock and equipment damage.
4. All wiring must comply with appropriate electrical codes, ordinances and regulations including NEC Class 1 (Line Voltage) wiring where required.

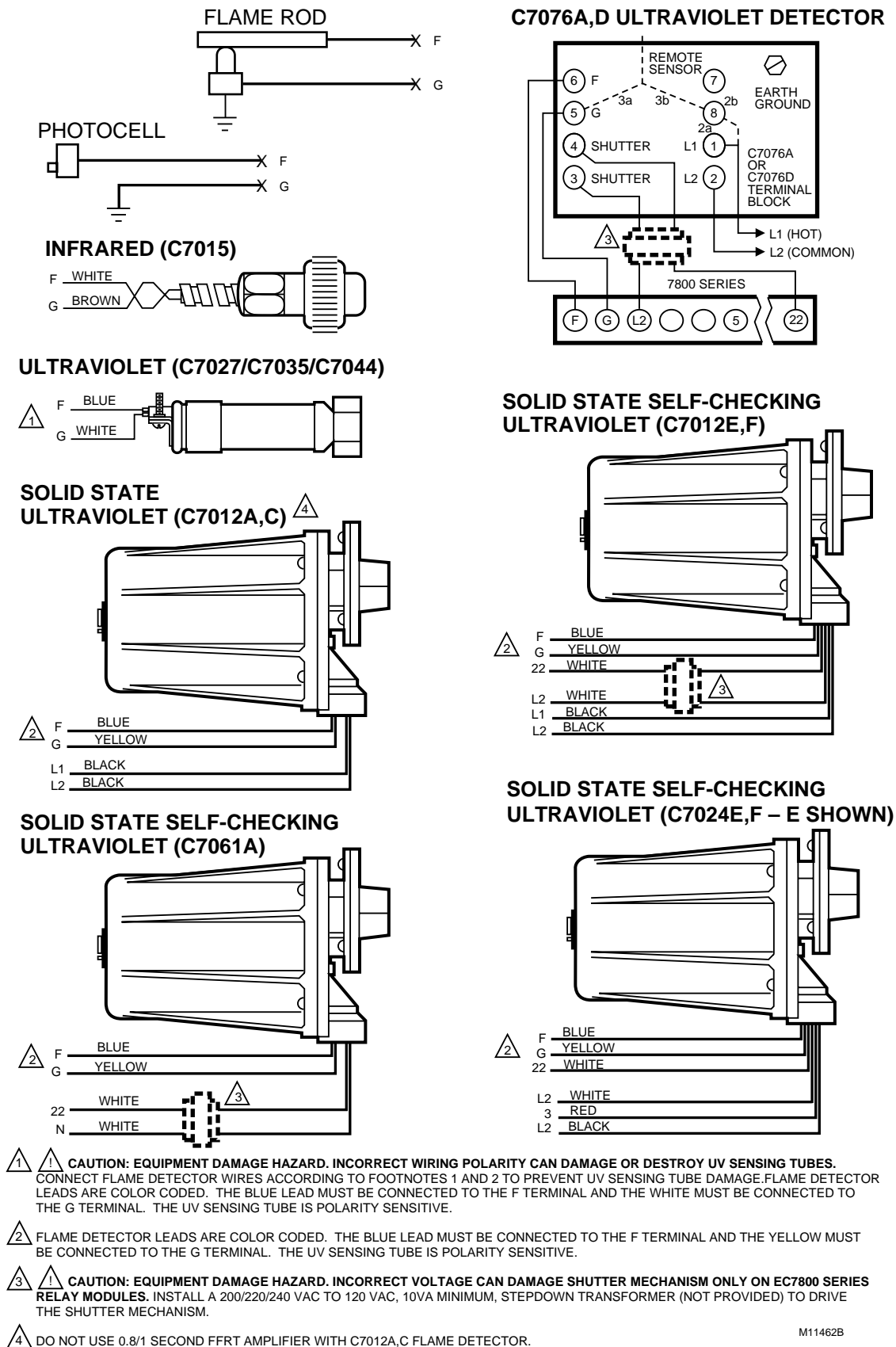

Fig. 3. Flame detector wiring.

5. Use recommended wire size and type no. 18 copper conductors TTW(60C) or THW (75C) or THNN(90C).
6. Use recommended wire routing:
 - a. Keep the flame signal leadwire as short as possible from the detector to the 7800 SERIES Relay Module. The maximum permissible leadwire length depends on the type of leadwire, conduit type and leadwire diameter. The ultimate limiting factor for flame signal leadwire length is the flame signal voltage.
 - b. Do not run high voltage ignition transformer wires in the same conduit with the flame detection wiring.
 - c. If the flame detector leadwires are not long enough to reach the 7800 SERIES Relay Module electrical connectors, make splices in a junction box.
 1. Enclose scanner wiring without armor cable in metal cable or conduit.
 2. Follow flame detector Instructions.
7. Check wiring, see Fig. 4.
8. Install 7800 SERIES Relay Module.
9. Restore power to the 7800 SERIES Relay Module.

- 3 Amplifier is securely mounted on the 7800 SERIES Relay Module.
- 4 Detectors are properly positioned and cleaned according to Detector Instructions.
- 5 Correct combination of amplifier and flame detector is used.

Flame Signal Measurement (Fig. 4)

Flame signal can be measured at the Flame Signal Test Jacks, see Fig. 4, and at the Keyboard Display Module. Measure the flame signal at the appropriate times defined in the Checkout section; see applicable 7800 SERIES Relay Module Instructions. See Table 3 for acceptable and maximum flame signal voltage strengths.

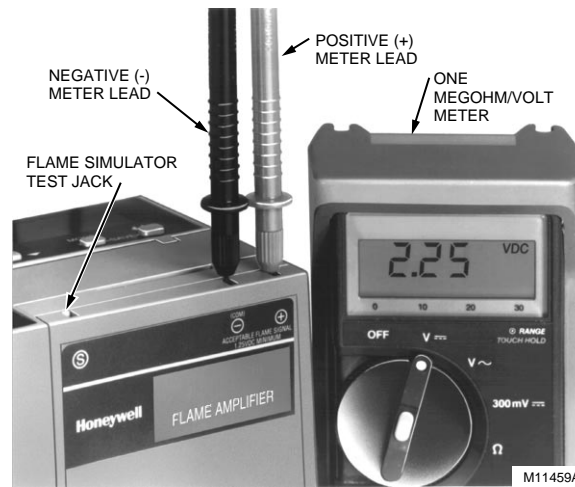

Fig. 4. Flame signal measurement with meter.

Flame detector wiring is shown in Fig. 3.

CHECKOUT

Preliminary Inspection

Make certain that:

- 1 Wiring connections are correct and all terminal screws and electrical connections are tight.
- 2 Proper flame failure response time is selected.

Table 3. Flame signal.

Flame Detector	Flame Signal Amplifier	Minimum Acceptable Steady dc Voltage ^a	Maximum Expected dc Voltage
Flame Rod Photocell C7012A,C ^c	R7847A,B ^b	1.25 Vdc	5.0 Vdc at Keyboard Display Module or on volt-ohmmeter ^e
C7012E,F ^c	R7847C ^{d,e}		
C7015A	R7848A,B ^b		
C7024E,F	R7824C ^{d,e}		
C7027A C7035A C7044A	R7849A,B ^b		
C7061A	R7861A ^d		
C7076A,D	R7886A ^d		

^a This minimum or stronger signal can be easily obtained if the detector is correctly installed and positioned to properly sense the flame. Obtain this voltage before completing checkout.

^b The flame amplifiers are Ampli-Check® type.

^c Adjust slightly, or face the pipe down, or extend the sight pipe on C7012A,C,E,F applications to obtain a maximum flame signal reading less than 5.0 volts.

^d The flame signal amplifier circuitry is tested one-half second every five seconds during burner operation and shuts down the burner if the amplifier fails (all installations).

^e R7824C, Series 2 or greater, and R7847C, Series 4 or greater, pulse the shutter when the flame signal reaches 1.5 Vdc.



CAUTION

Equipment Damage Hazard. Improper wiring can destroy ultraviolet sensing tube.

Carefully follow polarity sensitive wiring instructions for the C7027, C7035, C7044, C7012, C7024, C7061 and C7076. Reversing the leadwires, even momentarily, can destroy the ultraviolet sensing tube.

1. Connect blue leadwire from detector to terminal F and white leadwire from C7027/C7035/C7044/C7061 to terminal G.
2. Connect blue leadwire from detector to terminal F and yellow leadwire from C7012/C7024 to terminal G.
3. Follow lightoff Instructions for applicable 7800 SERIES Relay Module.

Measuring Flame Signal With Keyboard Display Module

Consult Instructions for applicable 7800 SERIES Relay Module or Keyboard Display Module.

Measuring Flame Signal with a Volt Ohmmeter

Two test jacks, positive and negative (Com) are accessible on the top of the amplifier when plugged into the 7800 SERIES Relay Module. These jacks are provided for monitoring flame signal strength. Use a one megohm/volt meter to measure the flame signal strength. Connect the positive meter lead (red) to the positive (+) amplifier test jack and the negative meter lead (black) to the negative (-) amplifier test jack. The test jacks use standard 0.180 inch diameter voltmeter probes. A minimum 1.25 Vdc flame signal is required.

The flame signal for the pilot alone, the main burner flame alone, and both together must be steady and a minimum of 1.25V. If the flame signal is unsteady, or less than the minimum acceptable voltage, check the flame detector installation and circuitry in the following procedure.

1. Check the supply voltages at terminals (L1) and L2 (N). Make sure the master switch is closed, connections are correct, and the power supply is of the correct voltage and frequency and is sinusoidal.
2. Check the detector wiring for defects including:
 - a. Incorrect connections.
 - b. Wrong type of wire.
 - c. Deteriorated wire.
 - d. Open circuits.
 - e. Short circuits.
 - f. Leakage paths caused by moisture, soot or accumulated dirt.
3. For a flame rod, make sure:
 - a. There is enough ground area.
 - b. The flame rod is properly located in the flame.
 - c. Temperature at the flame rod insulator is no greater than 500°F (260°C).
4. For all optical detectors, clean the detector viewing window, lens, and inside of the sight pipe as applicable.
5. With the burner running, check the temperature at the detector. If it exceeds the detector maximum rated temperature:
 - a. Add a heat block to stop conducted heat traveling up the sight pipe.
 - b. Add a shield or screen to reflect radiated heat.
 - c. Add cooling (refer to sight pipe ventilation in the detector Instructions).
6. Make sure that the flame adjustment is not too lean.
7. Make sure the optical detector is properly sighting the flame.
8. If necessary, resight or reposition the detector.
9. If you cannot obtain proper operation, replace the plug-in amplifier.
10. If you cannot yet obtain proper operation, replace the flame detector.

IMPORTANT

If you make any changes to the flame detection system, repeat all required Checkout tests in Checkout section of the Instructions for the applicable 7800 SERIES Relay Module.

Home and Building Control

Honeywell Inc.
Honeywell Plaza
P.O. Box 524
Minneapolis MN 55408-0524

Honeywell Latin American Region

480 Sawgrass Corporate Parkway
Suite 200
Sunrise FL 33325

Home and Building Control

Honeywell Limited-Honeywell Limitée
155 Gordon Baker Road
North York, Ontario
M2H 3N7

Honeywell Europe S.A.

3 Avenue du Bourget
1140 Brussels
Belgium

Honeywell Asia Pacific Inc.

Room 3213-3225
Sun Hung Kai Centre
No. 30 Harbour Road
Wanchai
Hong Kong

Honeywell

