

These instructions explain how to replace blade seals in the field.

- 1) Open damper. Energize the actuator, or disconnect actuator linkage so blade will remain open. Warning: Damper will close if actuator is de-energized.
- 2) Scrape existing seal from frame perimeter using a putty knife or similar scraper. Solvent rinse the frame stop area to remove any dirt, oil or contaminant.
- 3) Replacement seal is either approximately square or "D" shaped. The flat surface of seal is to be oriented against the rolled bar stop and is to be located along perimeter. See Figure 1.

- 4) Apply a 1/8" bead of Tremco Spectrem 1 adhesive sealant to either the rolled bar or to the seal. Use scraper to distribute adhesive evenly.
- 5) Install seal in place. Cut to length so seal ends abut blade in open position.
- 6) Close blade. The will hold seal in place. Allow 24 hours for complete curing.

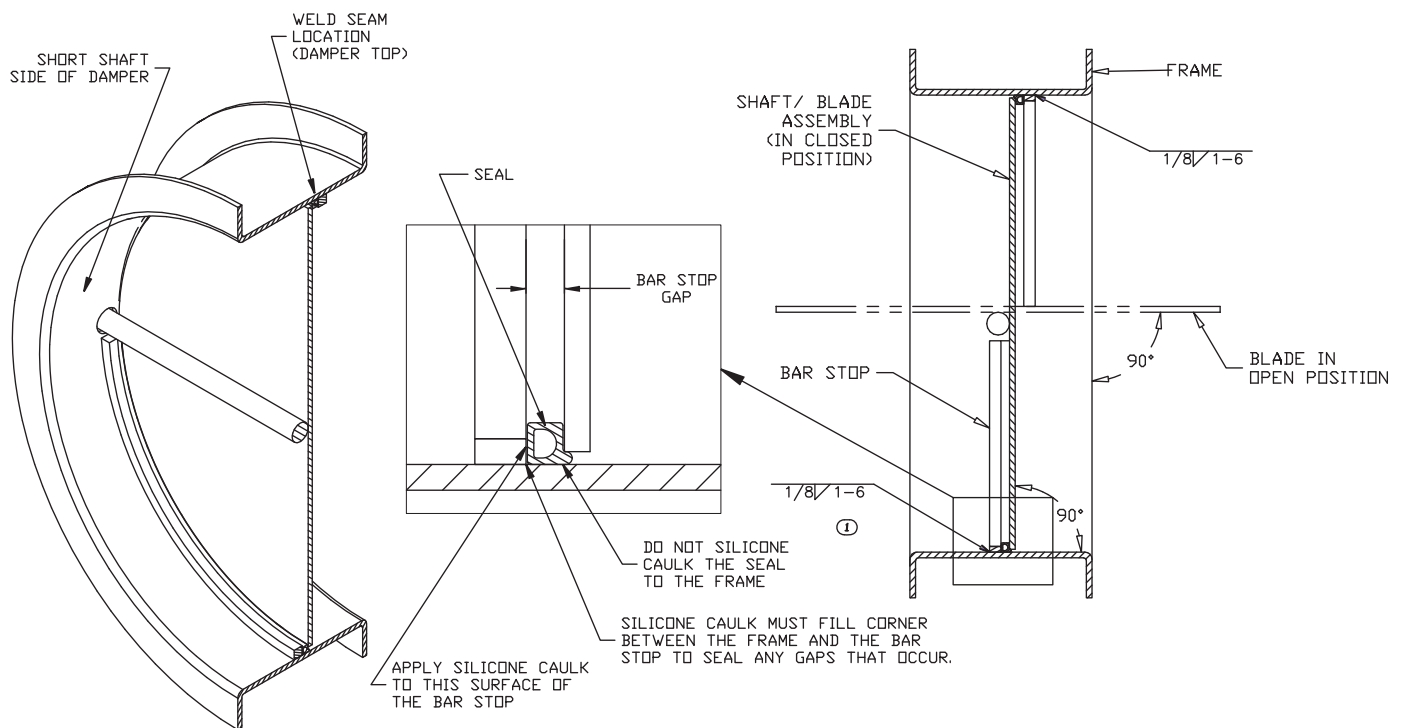

Figure 1

## Our Commitment

*As a result of our commitment to continuous improvement, Greenheck reserves the right to change specifications without notice.*

Product warranties can be found online at [Greenheck.com](http://Greenheck.com), either on the specific product page or in the literature section of the website at [Greenheck.com/Resources/Library/Literature](http://Greenheck.com/Resources/Library/Literature).