

These instructions explain how to replace blade seals in the field. Axle (shaft) penetrations through frame are protected by o-ring axle seals. The Viton o-rings may deteriorate due to abrasion, wear, oxidation or exposure to adverse chemicals. Replace as necessary. See Figure 1 & 2.

- 1) Remove actuator crankarms and interconnect linkage from axles. Smooth any burrs.
- 2) Remove external bearings and o-ring cover plate to expose the o-ring. It may be easiest to remove the o-ring stuffing box plate so as to facilitate o-ring removal.
- 3) Remove the old o-ring and the red silicone rubber gasket, if used, from the mounting surface.
- 4) Install new red silicone gasket or apply a thin layer of silicone caulk. Reinstall the o-ring stuffing box plate over the mounting studs.
- 5) Lubricate the new o-ring with petroleum jelly (Vaseline) and install into stuffing box plate.
- 6) Reinstall cover plate and external bearing. Tighten until the red silicone rubber gasket starts to squeeze from behind the o-ring stuffing box.
- 7) Reinstall drive linkage.

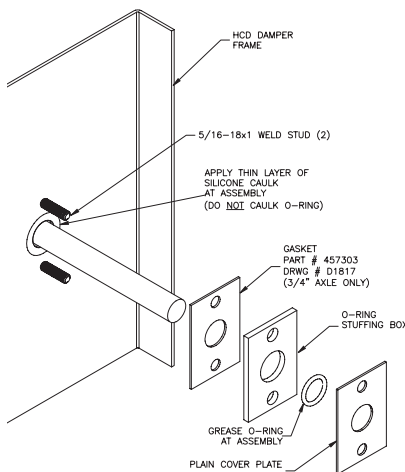
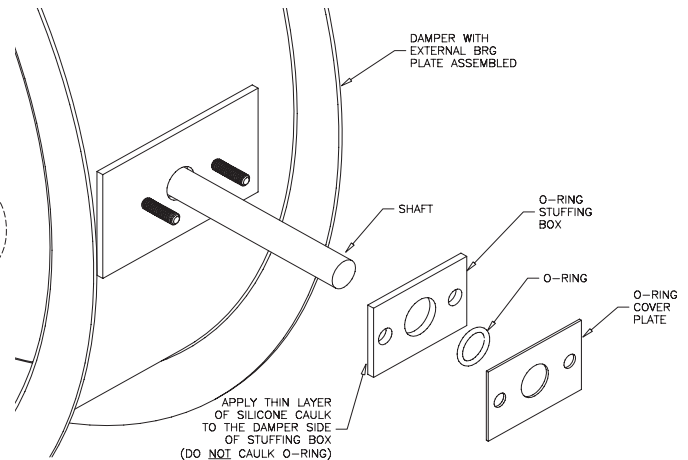
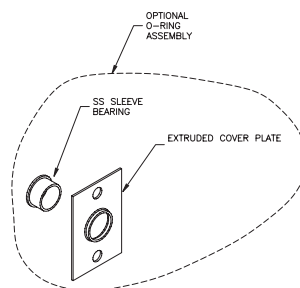

Figure 1



NOTE:
LUBRICATE O-RING WITH GREASE.

Figure 2

Our Commitment

As a result of our commitment to continuous improvement, Greenheck reserves the right to change specifications without notice.

Product warranties can be found online at Greenheck.com, either on the specific product page or in the literature section of the website at Greenheck.com/Resources/Library/Literature.