

Standard Construction

Frame	Heavy gauge extruded 5052-H32 aluminum, 5.5 in. (140 mm) x 0.25 in. (6 mm) nominal wall thickness
Blades	Chevron design, heavy gauge extruded 6061-T6 aluminum, 0.25 in. (6 mm) nominal wall thickness, positioned 45° on approximately 2 in. (51 mm) centers
Louver Depth	5.5 in. (152 mm)
Construction	Welded
Finish	Mill
Mounting	Channel Frame Recessed/Flush
Mounting Angles	The 1/4 in. (6 mm) thick frame is extended along the jambs, or head and sill, with mounting holes
Minimum Section Size	12 in. W x 12 in. H (305 mm W x 305 mm H)
Maximum Single Section Size	96 in. x 120 in. (2438 mm x 3048 mm) Limited to 50 sq. ft. (4.6 sq. m), maximum size is also dependent on frame configuration and finish process
Maximum Opening Width	Unlimited, larger openings may be configured of multiple louver panels without additional structural reinforcing when configured as head and sill mount
Approx. Weight	13 PSF (0.6 kPa), integral lifting lugs included
Wind Load	+/-250 PSF (1.2 kPa)

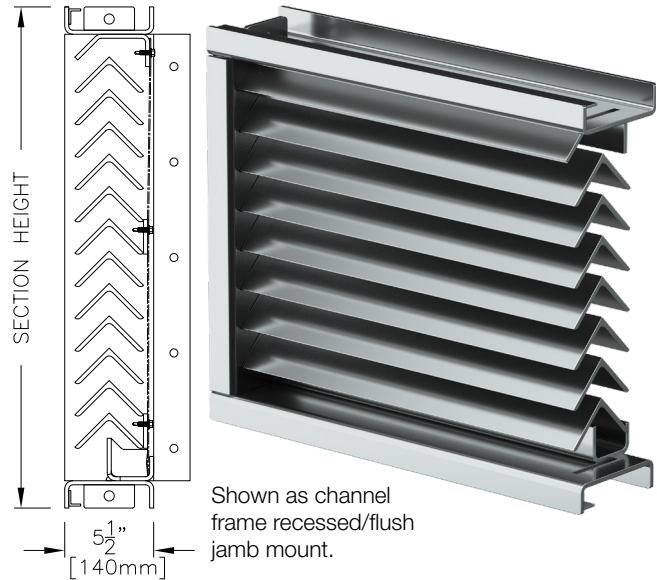

The AFL-501 is a UL Classified Wind-Storm Rated Assembly in accordance with FEMA Guidelines P-320 and P-361, and ICC 500 (2020) to static and cyclical design pressures of positive/negative 250 PSF and debris impact of a 15 lb sawn lumber 2x4 traveling at 100 MPH (6.8 kg at 44.7 m/s).



Performance Ratings



Greenheck Fan Corporation certifies that the AFL-501 louvers shown herein are licensed to bear the AMCA Seal. The ratings shown are based on tests and procedures performed in accordance with AMCA Publication 511 and comply with the requirements of the AMCA Certified Ratings Program. The AMCA Certified Ratings Seal applies to Water Penetration and Air Performance ratings.

Louvers were tested in accordance with AMCA Standard 500-L.

Performance of 48 in. x 48 in. (1219 mm x 1219 mm) Louver

Free Area	
Area	7.60 sq. ft. (0.706 sq. m)
Percent	47.5%
Performance at Beginning Point of Water Penetration	
Free Area Velocity	552.5 fpm (2.807 m/s)
Max Intake Volume	4199 cfm (1.982 m³/s)
Performance at 6,000 CFM (2.832 m³/s) Intake	
Pressure Drop	0.157 in. wg (0.039 kPa)

Options and Accessories

- Cantilever and Flange Style Mounting
- [Extended Sill](#)
- Flange Frame
- Head and Sill Mounting Configuration
- [Insect Screen](#)
- [Variety of Architectural Finishes](#)

Standard Details and IOMs

[AFL-501 Standard Details](#)

[Exterior Flange \(IOM #483327\)](#)

[Interior Flange \(IOM #483328\)](#)

[Exterior Cantilevered \(IOM #483329\)](#)

[Interior Cantilevered \(IOM #483330\)](#)

[Flush Mount \(IOM #483331\)](#)

Structural reinforcing members may be required to adequately support and install multiple louver sections within a large opening. Structural reinforcing members along with any associated installation hardware is not provided by Greenheck unless indicated otherwise by Greenheck. Options and accessories including, but not limited to, screens, filter racks, louver doors, and blank off panels are not subject to structural analysis unless indicated otherwise by Greenheck.

Free Area Chart

Free Area Chart shows free area in square feet.

Equivalent Cantilever R.O.Size		Rough Opening Width (Inches)																		
		-	12	14.13	20.13	26.13	32.13	38.13	44.13	50.13	56.13	60	62.13	68.13	72	74.13	80.13	86.13	92.13	96
Rough Opening Height (Inches)	Recessed/ Flanged	12	15.88	18	24	30	36	42	48	54	60	63.88	66	72	-	78	84	90	96	-
	-	12	0.24	0.35	0.41	0.58	0.76	0.93	1.11	1.28	1.45	1.62	1.74	1.80	1.97	2.08	2.15	2.32	2.50	2.67
12	15.88	0.37	0.54	0.64	0.91	1.17	1.44	1.71	1.98	2.24	2.51	2.69	2.78	3.05	3.23	3.32	3.59	3.86	4.13	4.31
14.13	18	0.43	0.64	0.75	1.07	1.38	1.70	2.02	2.34	2.64	2.96	3.16	3.28	3.59	3.80	3.91	4.23	4.55	4.86	5.07
20.13	24	0.62	0.92	1.09	1.55	2.01	2.47	2.93	3.39	3.83	4.29	4.59	4.75	5.21	5.51	5.67	6.14	6.60	7.06	7.36
26.13	30	0.82	1.21	1.42	2.03	2.63	3.23	3.84	4.44	5.02	5.63	6.02	6.23	6.83	7.23	7.44	8.04	8.65	9.25	9.64
32.13	36	1.01	1.49	1.76	2.51	3.25	4.00	4.75	5.50	6.21	6.96	7.44	7.71	8.46	8.94	9.20	9.95	10.70	11.45	11.93
38.13	42	1.21	1.78	2.10	2.99	3.88	4.77	5.66	6.55	7.40	8.30	8.87	9.19	10.08	10.65	10.97	11.86	12.75	13.64	14.21
44.13	48	1.40	2.07	2.43	3.47	4.50	5.54	6.57	7.60	8.60	9.63	10.30	10.66	11.70	12.37	12.73	13.77	14.80	15.83	16.50
50	53.88	1.59	2.35	2.77	3.95	5.13	6.30	7.48	8.66	9.79	10.96	11.72	12.14	13.32	14.08	14.50	15.67	16.85	18.03	18.79
50.13	54	1.59	2.35	2.77	3.95	5.13	6.30	7.48	8.66	9.79	10.96	11.72	12.14	13.32	14.08	14.50	15.67	16.85	18.03	
56.13	60	1.79	2.64	3.11	4.43	5.75	7.07	8.39	9.71	10.98	12.30	13.15	13.62	14.94	15.79	16.26	17.58	18.90	20.22	
62.13	66	1.98	2.93	3.45	4.91	6.37	7.84	9.30	10.77	12.17	13.63	14.58	15.10	16.56	17.51	18.02	19.49	20.95	22.42	
67	-	2.15	3.18	3.75	5.34	6.93	8.52	10.11	11.70	13.23	14.82	15.84	16.41	18.00	19.03					
68.13	72	2.18	3.21	3.78	5.39	7.00	8.61	10.21	11.82	13.36	14.97	16.00	16.57	18.18						
72.13	76	2.31	3.41	4.01	5.71	7.41	9.12	10.82	12.52	14.15	15.86	16.96	17.56	19.26						
74.13	78	2.37	3.50	4.12	5.87	7.62	9.37	11.12	12.87	14.55	16.30	17.43								
80.13	84	2.56	3.79	4.46	6.35	8.25	10.14	12.03	13.93	15.74	17.64	18.86								
86.13	90	2.76	4.07	4.80	6.83	8.87	10.91	12.94	14.98	16.93	18.97	20.29								
92.13	96	2.95	4.36	5.13	7.31	9.49	11.67	13.85	16.03	18.12	20.30	21.71								
98.13	102	3.15	4.65	5.47	7.79	10.12	12.44	14.76	17.09	19.31	21.64	23.14								
104.13	108	3.34	4.93	5.81	8.27	10.74	13.21	15.67	18.14	20.51	22.97	24.57								
110.13	114	3.53	5.22	6.14	8.75	11.37	13.98	16.59	19.20	21.70	24.31	25.99								
116.13	120	3.73	5.51	6.48	9.24	11.99	14.74	17.50	20.25	22.89	25.64	27.42								
120	-	-	5.70	6.71	9.56	12.40	15.25	18.10	20.95	23.68	26.53	28.37								

Document Links

[Louver Finishes & Colors](#)

[Louver Product Selection Guide](#)

[Louver Products Catalog](#)

[Louver Warranty Statement](#)

Free Area Chart

Free Area Chart shows free area in square meters.

		Rough Opening Width (Meters)																			
		-	0.30	0.36	0.51	0.66	0.82	0.97	1.12	1.27	1.43	1.52	1.58	1.73	1.83	1.88	2.04	2.19	2.34	2.44	
Equivalent Cantilever R.O.Size	Recessed/ Flanged	0.30	0.40	0.46	0.61	0.76	0.91	1.07	1.22	1.37	1.52	1.62	1.68	1.83	-	1.98	2.13	2.29	2.44	-	
	-	0.30	0.01	0.01	0.01	0.01	0.02	0.02	0.03	0.03	0.04	0.04	0.04	0.05	0.05	0.05	0.05	0.06	0.06	0.07	-
0.30	0.40	0.01	0.01	0.02	0.02	0.03	0.04	0.04	0.05	0.06	0.06	0.07	0.07	0.08	0.08	0.08	0.09	0.10	0.10	0.11	
0.36	0.46	0.01	0.02	0.02	0.03	0.04	0.04	0.05	0.06	0.07	0.08	0.08	0.08	0.09	0.10	0.10	0.11	0.12	0.12	0.13	
0.51	0.61	0.02	0.02	0.03	0.04	0.05	0.06	0.07	0.09	0.10	0.11	0.12	0.12	0.13	0.14	0.14	0.16	0.17	0.18	0.19	
0.66	0.76	0.02	0.03	0.04	0.05	0.07	0.08	0.10	0.11	0.13	0.14	0.15	0.16	0.17	0.18	0.19	0.20	0.22	0.23	0.24	
0.82	0.91	0.03	0.04	0.04	0.06	0.08	0.10	0.12	0.14	0.16	0.18	0.19	0.20	0.21	0.23	0.23	0.25	0.27	0.29	0.30	
0.97	1.07	0.03	0.05	0.05	0.08	0.10	0.12	0.14	0.17	0.19	0.21	0.23	0.23	0.26	0.27	0.28	0.30	0.32	0.35	0.36	
1.12	1.22	0.04	0.05	0.06	0.09	0.11	0.14	0.17	0.19	0.22	0.24	0.26	0.27	0.30	0.31	0.32	0.35	0.38	0.40	0.42	
1.27	1.37	0.04	0.06	0.07	0.10	0.13	0.16	0.19	0.22	0.25	0.28	0.30	0.31	0.34	0.36	0.37	0.40	0.43	0.46	0.48	
1.27	1.37	0.04	0.06	0.07	0.10	0.13	0.16	0.19	0.22	0.25	0.28	0.30	0.31	0.34	0.36	0.37	0.40	0.43	0.46		
1.43	1.52	0.05	0.07	0.08	0.11	0.15	0.18	0.21	0.25	0.28	0.31	0.33	0.35	0.38	0.40	0.41	0.45	0.48	0.51		
1.58	1.68	0.05	0.07	0.09	0.12	0.16	0.20	0.24	0.27	0.31	0.35	0.37	0.38	0.42	0.44	0.46	0.50	0.53	0.57		
1.70	-	0.05	0.08	0.10	0.14	0.18	0.22	0.26	0.30	0.34	0.38	0.40	0.42	0.46	0.48						
1.73	1.83	0.06	0.08	0.10	0.14	0.18	0.22	0.26	0.30	0.34	0.38	0.41	0.42	0.46							
1.83	1.93	0.06	0.09	0.10	0.15	0.19	0.23	0.27	0.32	0.36	0.40	0.43	0.45	0.49							
1.88	1.98	0.06	0.09	0.10	0.15	0.19	0.24	0.28	0.33	0.37	0.41	0.44									
2.04	2.13	0.07	0.10	0.11	0.16	0.21	0.26	0.31	0.35	0.40	0.45	0.48									
2.19	2.29	0.07	0.10	0.12	0.17	0.23	0.28	0.33	0.38	0.43	0.48	0.52									
2.34	2.44	0.07	0.11	0.13	0.19	0.24	0.30	0.35	0.41	0.46	0.52	0.55									
2.49	2.59	0.08	0.12	0.14	0.20	0.26	0.32	0.37	0.43	0.49	0.55	0.59									
2.64	2.74	0.08	0.13	0.15	0.21	0.27	0.34	0.40	0.46	0.52	0.58	0.62									
2.80	2.90	0.09	0.13	0.16	0.22	0.29	0.36	0.42	0.49	0.55	0.62	0.66									
2.95	3.05	0.09	0.14	0.16	0.23	0.30	0.37	0.44	0.51	0.58	0.65	0.70									
3.05	-	-	0.14	0.17	0.24	0.31	0.39	0.46	0.53	0.60	0.67	0.72									

Airflow Resistance

Standard Air - 0.075 lb/ft³ (1.2 kg/m³)

Test size 48 in. x 48 in. (1219 mm x 1219 mm)

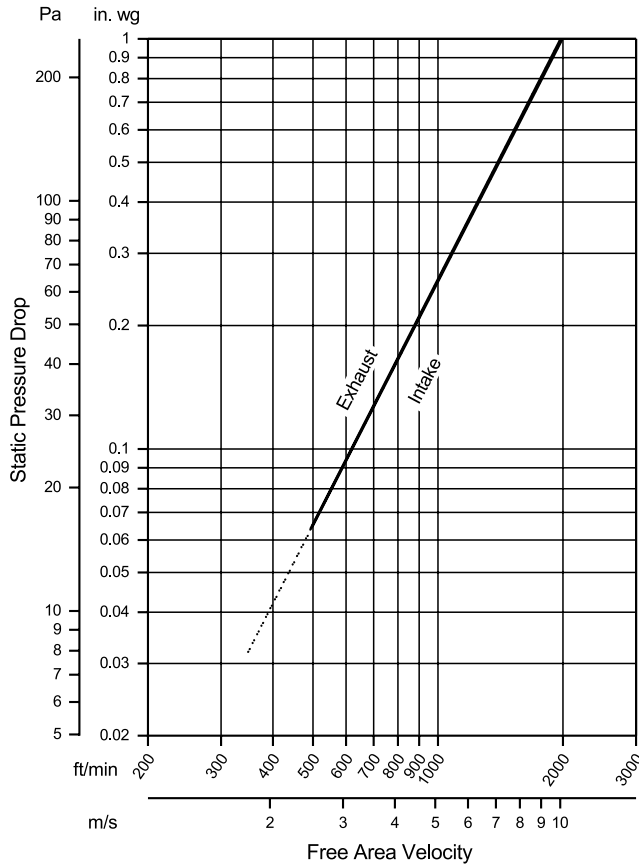

Model AFL-501 resistance to airflow (pressure drop) varies depending on louver application (air intake or air exhaust). Free area velocities (shown) are higher than average velocity through the overall louver size. See louver selection information. (Test Figure 5.5-6.5)

Water Penetration

Standard Air - 0.075 lb/ft³ (1.2 kg/m³)

Test size 48 in. x 48 in. (1219 mm x 1219 mm)

Test duration of 15 min.

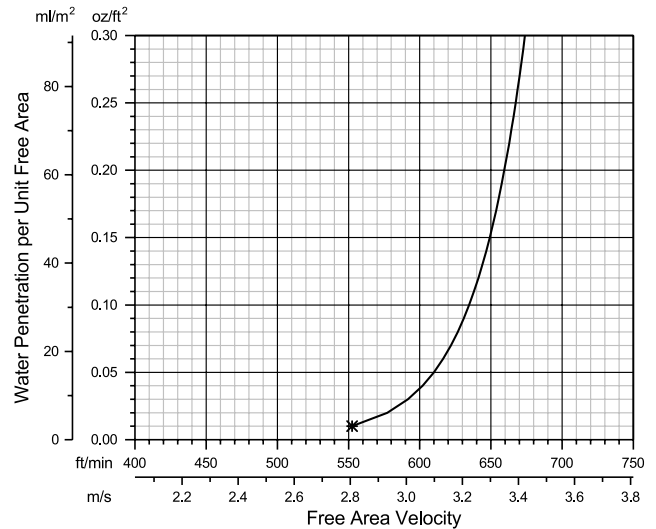

The AMCA Water Penetration Test provides a method for comparing various louver models and designs as to their efficiency in resisting the penetration of rainfall under specific laboratory test conditions. The beginning point of water penetration is defined as that velocity where the water penetration curve projects through 0.01 oz. (3 g) of water (penetration) per sq. ft. (m²) of louver free area. ***The beginning point of water penetration for Model AFL-501 is 552.5 fpm (2.807 m/s) free area velocity.** These performance ratings do not guarantee a louver to be weatherproof or stormproof and should be used in combination with other factors including good engineering judgement in selecting louvers.