

## Application

Adjustable Pressure Controller (APC) allows field setting of relief pressure on all EM series dampers. Use one per panel. Maximum recommended pressure set limitations are as follows:

- EM series damper must be equipped with counterbalance
- One per section is required

Area		Maximum Set Pressure	
(ft <sup>2</sup> )	(m <sup>2</sup> )	(in. wg)	(Pa)
4	0.37	0.75	187
6	0.58	0.50	125
8	0.74	0.40	100
10	0.93	0.30	75
15	1.40	0.20	50
20	1.86	0.15	37
24	2.23	0.125	31

EM-10, Horizontal Mount, Vertical Airflow Up  
 EM-30, Vertical Mount, Horizontal Airflow  
 EM-40, Horizontal Mount, Vertical Airflow Down

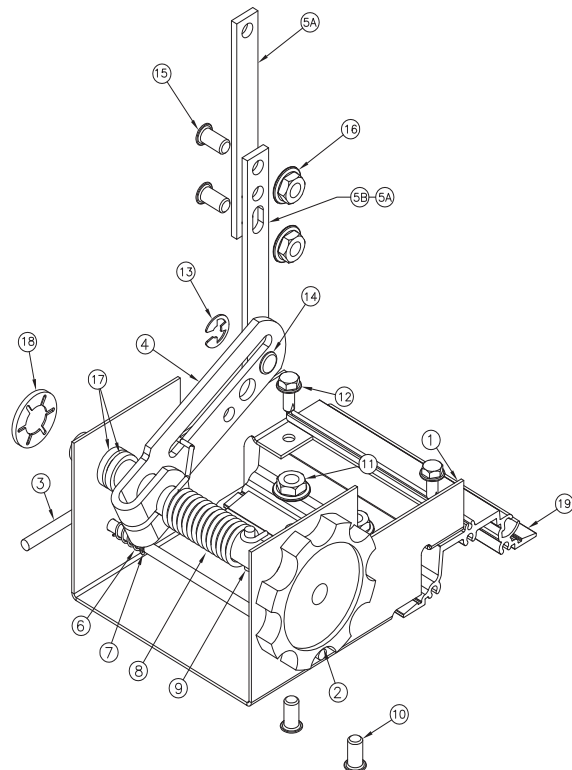

Item #	Part #	Description	Qty
1	705238	Mounting Bracket	1
2	823936	Control Knob Sub-Assembly	1
3	705241	Release Rod	1
4	653631	1/2 in. Non-Knurled Crankarm	1
5A	705239	Connecting Bar (4 1/8 in. long)	*
5B	705240	Connecting Bar (3 in. long)	*
6	457803	Spring	2
7	457806	3/16 in. E-Clip	1
8	463906	Link Separator Spring -SS	1
9	454092	5/32 in. x 1.5 Roll Pin - SS	1
10	416052	#10-32 x 5/8 in. SS Threadstud	2
11	415991	#10-32 Keps Nut -SS	2
12	415555	#10 x 1/2 in. Tek Screw - ZP	2
13	451588	1/4 in. E-clip- ZP	1
14	451820	1/4 x 0.360 in. Knurl Pin - ZP	1
15	415609	1/4 - 20 x 1/2 in. Threadstud	2
16	415455	1/4 - 20 Spinlock Nut-ZP	2
17	415482	3/16 x 1/2 in. nylon washer	2
18	416179	1/2 in. Push-On Retainer-ZP	1
19		Frame sill of damper	

\* See installation instructions for correct connecting bar

## AMCA Test Figure 5.3

Figure 5.3 illustrates a fully ducted damper. This configuration has low pressure drop because entrance and exit losses are minimized by straight duct runs upstream and downstream of the damper.

### Pressure Drop Data

This pressure drop data was conducted in accordance with AMCA Standard 500-D using Test Figure 5.3. All data has been corrected to represent standard air at a density of 0.075 lb/ft<sup>3</sup> (1.2 kg/m<sup>3</sup>).

Actual pressure drop found in any HVAC system is a combination of many factors. This pressure drop information along with an analysis of other system influences should be used to estimate actual pressure losses for a damper installed in a given HVAC system.

**AMCA Test Figure 5.3**

