

Application

Model DFD-150 is approved for use in walls, floors, and partitions with fire resistance ratings less than 3 hours. This model carries a 1½ hour UL 555 fire damper label and is dynamic rated for use in HVAC systems that are operational in the event of fire.

Ratings

UL 555 Fire Resistance

Fire Rating: 1½ hours

Velocity

4000 fpm (20.3 m/s) vertical mount only, up to 24 in. x 24 in. (610mm x 610mm);
2000 fpm (10.2 m/s) vertical or horizontal mount all sizes

Pressure

Maximum: 4 in. wg (1 kPa)



* W & H dimensions furnished approximately ¼ in. (6mm) undersize.

Construction

Construction	Standard	Optional
Frame Material	Galvanized steel*	-
Frame Depth	3 11/16 in. (94mm)	-
Blade Material	Galvanized steel*	-
Closure Spring	Stainless steel	-
Fusible Link	165°F (74°C)	212°F or 286°F (100°C or 141°C)
Mounting	Vertical	Horizontal

* in gauges required by UL listing R13317



See complete marking on product.
UL 555 Classification R13317

Model DFD-150 meets the requirements for fire dampers established by:

National Fire Protection Association
(NFPA Standards 80, 90A & 101)

Underwriters Laboratories Standard 555
(Listing #R13317)

IBC International Building Codes

California State Fire Marshall
(Listing #3225-981:102)

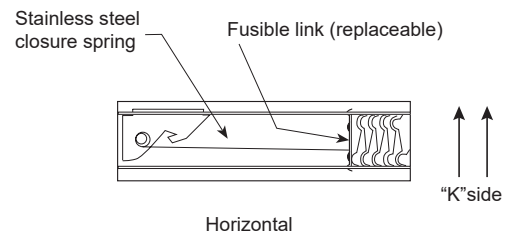
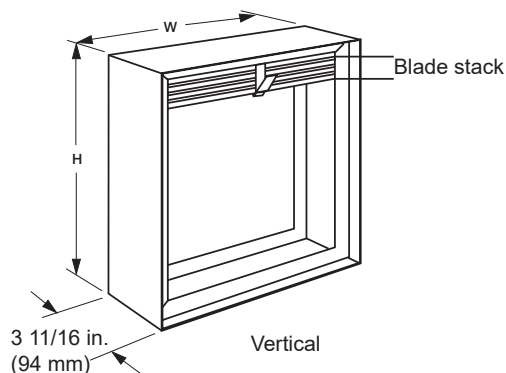

Options and Accessories

- [Breakaway connections](#)
- Clean wrap
- Closed indicator switch
- Flanges
- [Grille tabs](#)
- [Retaining angles](#)
- Sealed transitions and sleeve
- Transitions: B, B2, C, CO, CR, R

Document Links



[INSTALLATION](#)



[CATALOG](#)



[SELECTION GUIDE](#)



[SPECIFICATIONS](#)



[WARRANTY](#)

Factory Sleeve Option

All fire damper installations require the use of sleeves, angles and methods described in the installation instructions. Sleeves can be field fabricated or factory furnished as a completed damper/sleeve assembly.

Sleeves are galvanized steel and are available in 20 through 10 ga. (1mm - 3.5mm) thickness and lengths up to 36 in. (914mm).

“K” dimension specifies location of damper within the sleeve. Minimum is 4 in. (102mm), maximum is “L” less 4 in. (102mm), which allows for retaining angle installation, and duct connection at each end of the sleeve. If “K” dimension is not specified, it will be provided as one half of “L” dimension (damper centered in sleeve).

Note: If using access doors, the door should be installed on the “K” side of the damper.

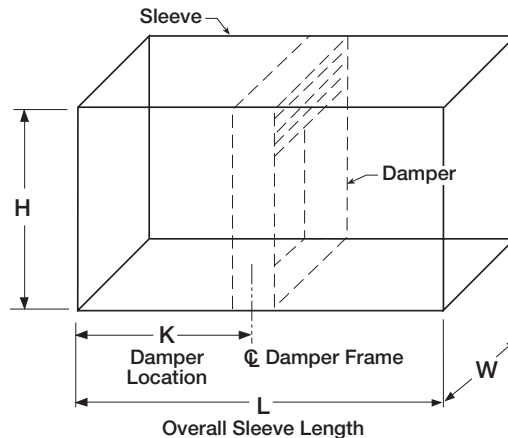

Sealed Option

When sealed option is selected, damper sleeve will be sealed to the damper frame or selected transition using UL approved sealant. For B transitions, the corners will need to be field sealed in the area where the duct to sleeve connection is made.

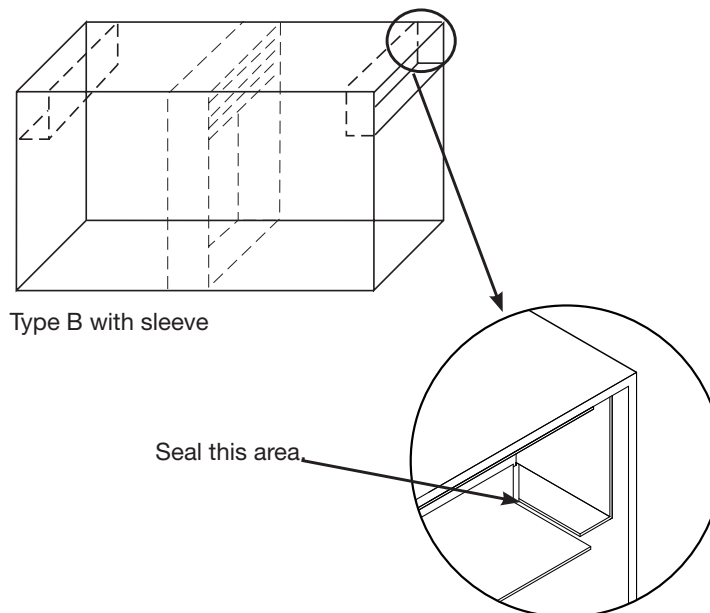

Type A, B, & B2

Dampers larger than maximum single section sizes are supplied in 2 or more sections of equal size. Multi-section dampers are factory assembled ready for installation.

Size Limitations

Inches (mm)	Type A		Type B & B2	
	Minimum	Maximum*	Minimum	Maximum*
Single Section Vertical	4 x 4 (102 x 102)	36 x 36 (914 x 914)	4 x 3 (102 x 76)	36 x 31 (914 x 787)
Multi Section** Vertical	NA	72 x 48 (1829 x 1219), 60 x 60 (1524 x 1524) or 120 x 30 (3048 x 762)	NA	72 x 45 (1829 x 1143), 60 x 56 (1524 x 1422) or 120 x 26 (3048 x 660)
Single Section Horizontal	4 x 4 (102 x 102)	30 x 30 (762 x 762)	4 x 3 (102 x 76)	30 x 26 (762 x 660)
Multi Section** Horizontal	NA	48 x 36 (1219 x 914)	NA	48 x 33 (1219 x 838)

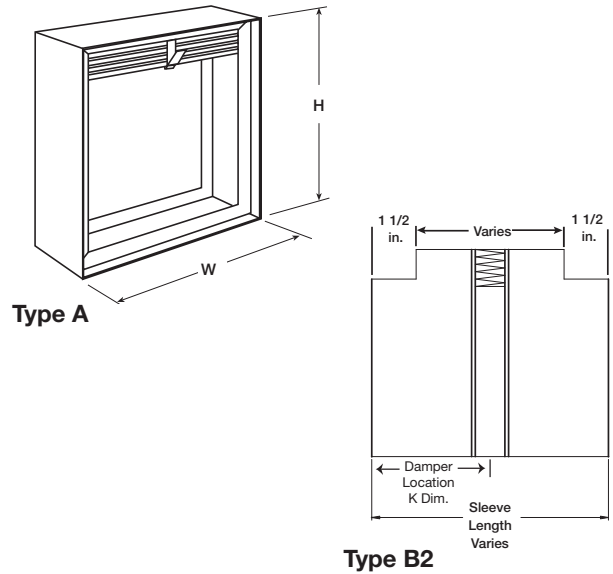

* Sizes are based on 165°F closure temperature and 2000 fpm. Consult factory for maximum size for different temperatures and velocities.

** Consult factory for number of sections.

Maximum Single Section Dimensions

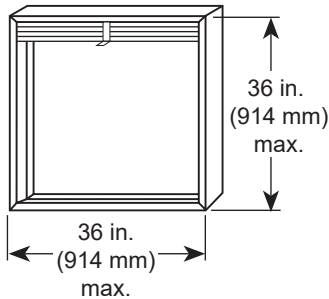

Type A Single Section

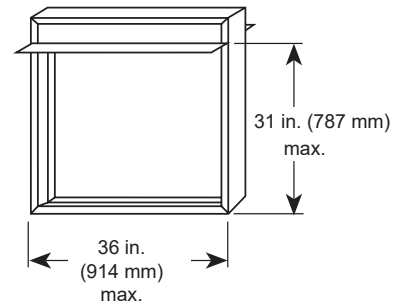

Type B Single Section

Maximum Multi-Section Dimensions

Maximum damper height is 48 in. (1219 mm) when combination width is 72 in. (1829 mm) or less.

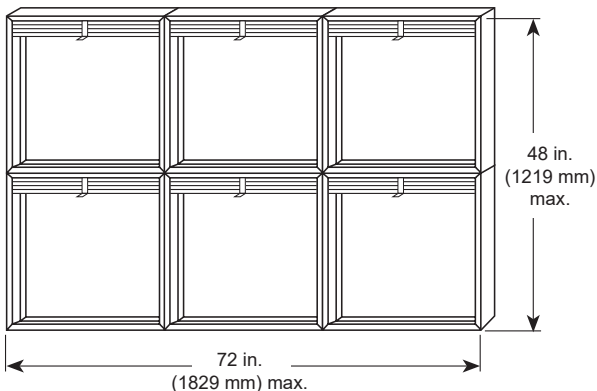

Maximum damper height is 45 in. (1143 mm) when combination width is 72 in. (1829 mm) or less.

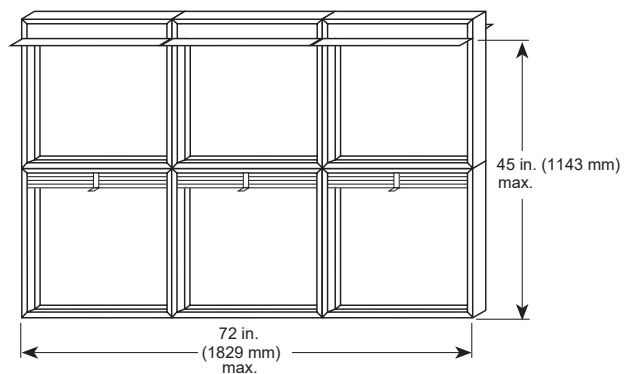

Multi Section Limitations - Type B/B2

Multi-Section Limitations - Type A

Note: All multi-section dampers with transitions will include a factory sleeve. When transition type is B or B2 on multi-section high dampers, the top section(s) are Type B or B2 and the bottom section(s) are Type A.

Type B & B2 Overall Dimensions

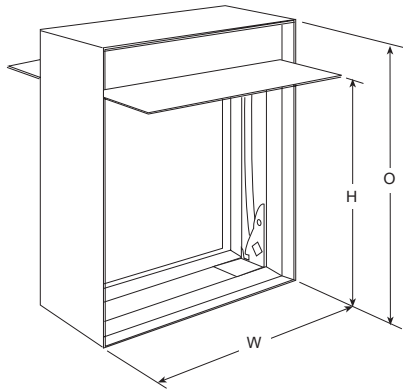

Type B

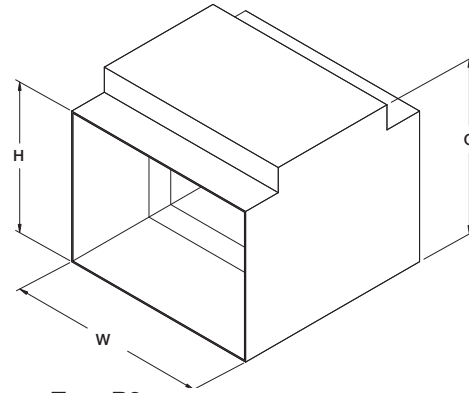

Type B2

Vertical Mount

H*	O*	H*	O*
3 (76)	5 (127)	30 (762)	34 (864)
4 (102)	6 (152)	31 (787)	36 (914)
5 (127)	7 (178)	32 (813)	37 (940)
6 (152)	8 (203)	33 (838)	37 (940)
7 (178)	9 (229)	34 (864)	37 (940)
8 (203)	10 (254)	35 (889)	38 (965)
9 (229)	11 (279)	36 (914)	39 (991)
10 (254)	12 (305)	37 (940)	40 (1016)
11 (279)	13 (330)	38 (965)	41 (1041)
12 (305)	14 (356)	39 (991)	42 (1067)
13 (330)	15 (381)	40 (1016)	43 (1092)
14 (356)	16 (406)	41 (1041)	44 (1118)
15 (381)	18 (457)	42 (1067)	45 (1143)
16 (406)	19 (483)	43 (1092)	46 (1168)
17 (432)	20 (508)	44 (1118)	47 (1194)
18 (457)	21 (533)	45 (1143)	48 (1219)
19 (483)	22 (559)	46 (1168)	50 (1270)
20 (508)	23 (584)	47 (1194)	51 (1295)
21 (533)	24 (610)	48 (1219)	52 (1321)
22 (559)	26 (660)	49 (1245)	53 (1346)
23 (584)	27 (686)	50 (1270)	54 (1372)
24 (610)	28 (711)	51 (1295)	55 (1397)
25 (635)	29 (737)	52 (1321)	56 (1422)
26 (660)	30 (762)	53 (1346)	57 (1448)
27 (686)	31 (787)	54 (1372)	58 (1473)
28 (711)	32 (813)	55 (1397)	59 (1499)
29 (737)	33 (838)	56 (1422)	60 (1524)

Horizontal Mount

H*	O*	H*	O*
3 (76)	5 (127)	19 (483)	22 (559)
4 (102)	6 (152)	20 (508)	23 (584)
5 (127)	7 (178)	21 (533)	24 (610)
6 (152)	8 (203)	22 (559)	26 (660)
7 (178)	9 (229)	23 (584)	27 (686)
8 (203)	10 (254)	24 (610)	28 (711)
9 (229)	11 (279)	25 (635)	29 (737)
10 (254)	12 (305)	26 (660)	30 (762)
11 (279)	13 (330)	27 (686)	31 (787)
12 (305)	14 (356)	28 (711)	31 (787)
13 (330)	15 (381)	29 (737)	32 (813)
14 (356)	16 (406)	30 (762)	33 (838)
15 (381)	18 (457)	31 (787)	34 (864)
16 (406)	19 (483)	32 (813)	35 (889)
17 (432)	20 (508)	33 (838)	36 (914)
18 (457)	21 (533)	-	-

* Dimensions are in inches (mm). These dimensions are furnished approximately 1/4 in. (6mm) undersize. All 'H' dimensions larger than single section height are two sections high. Refer to size limitations chart.

Type C, CO, & CR

Dampers larger than maximum single section sizes are supplied in 2 or more sections of equal size. Dimensions are in inches (mm).

Inches (mm)	Type CR		Type CO & C	
	Minimum	Maximum*	Minimum	Maximum*
Single Section Vertical	3 (76)	30 (762)	3 x 3 (76 x 76)	34 x 30 (864 x 762)
Multi Section Vertical**	NA	55 (1397)	NA	70 x 44 (1778 x 1118), 58 x 55 (1473 x 1397) or 118 x 25 (2997 x 635)
Single Section Horizontal	3 (76)	25 (635)	3 x 3 (76 x 76)	28 x 25 (711 x 635)
Multi Section Horizontal**	NA	32 (813)	NA	46 x 32 (1163 x 787)

* Sizes are based on 165°F closure temperature and 2000 fpm. Consult factory for maximum size for different temperatures and velocities.

** Consult factory for number of sections.

Maximum Single Section Dimensions

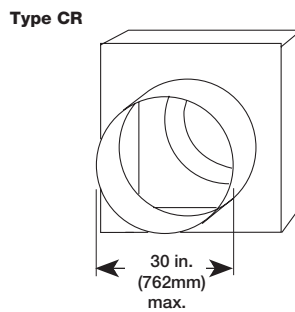
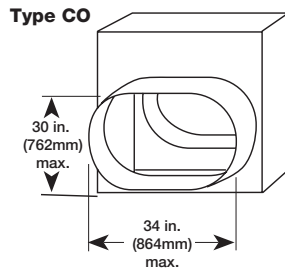
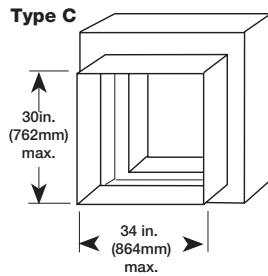

Overall Damper Dimensions

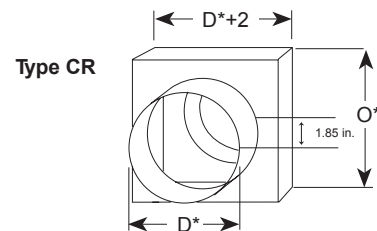
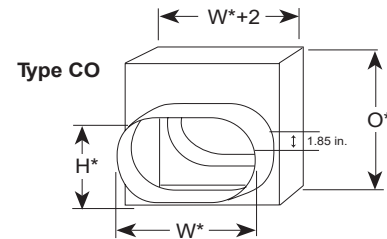
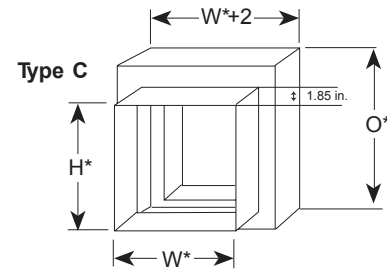

*See page 7 for O dimension information.

C, CO, CR transitions are positioned 1 in. (25mm) from bottom of sleeve.

Note: All multi-section dampers with transitions will include a factory sleeve.

Vertical Mount

H* or D*	O*	H* or D*	O*	H* or D*	O*
3 (76)	6 (152)	21 (533)	26 (660)	39 (991)	45 (1143)
4 (102)	7 (178)	22 (559)	27 (686)	40 (1016)	46 (1168)
5 (127)	8 (203)	23 (584)	28 (711)	41 (1041)	47 (1194)
6 (152)	9 (229)	24 (610)	29 (737)	42 (1067)	48 (1219)
7 (178)	10 (254)	25 (635)	30 (762)	43 (1092)	49 (1245)
8 (203)	11 (279)	26 (660)	31 (787)	44 (1118)	50 (1270)
9 (229)	12 (305)	27 (686)	32 (813)	45 (1143)	50 (1270)
10 (254)	13 (330)	28 (711)	33 (838)	46 (1168)	51 (1295)
11 (279)	14 (356)	29 (737)	34 (864)	47 (1194)	52 (1321)
12 (305)	15 (381)	30 (762)	36 (914)	48 (1219)	53 (1346)
13 (330)	16 (406)	31 (787)	37 (940)	49 (1245)	54 (1372)
14 (356)	18 (457)	32 (813)	37 (940)	50 (1270)	55 (1397)
15 (381)	19 (483)	33 (838)	39 (991)	51 (1295)	56 (1422)
16 (406)	20 (508)	34 (864)	40 (1016)	52 (1321)	57 (1448)
17 (432)	21 (533)	35 (889)	41 (1041)	53 (1346)	58 (1473)
18 (457)	22 (559)	36 (914)	42 (1067)	54 (1372)	59 (1499)
19 (483)	23 (584)	37 (940)	43 (1092)	55 (1397)	60 (1524)
20 (508)	24 (610)	38 (965)	44 (1118)	-	-

Horizontal Mount

H* or D*	O*	H* or D*	O*
3 (76)	6 (152)	18 (457)	22 (559)
4 (102)	7 (178)	19 (483)	23 (584)
5 (127)	8 (203)	20 (508)	24 (610)
6 (152)	9 (229)	21 (533)	26 (660)
7 (178)	10 (254)	22 (559)	27 (686)
8 (203)	11 (279)	23 (584)	28 (711)
9 (229)	12 (305)	24 (610)	29 (737)
10 (254)	13 (330)	25 (635)	30 (762)
11 (279)	14 (356)	26 (660)	31 (787)
12 (305)	15 (381)	27 (686)	31 (787)
13 (330)	16 (406)	28 (711)	32 (813)
14 (356)	18 (457)	29 (737)	33 (838)
15 (381)	19 (483)	30 (762)	34 (864)
16 (406)	20 (508)	31 (787)	35 (889)
17 (432)	21 (533)	32 (813)	36 (914)

* Dimensions are in inches (mm). These dimensions are furnished approximately ¼ in. (6mm) undersize, except round and oval dimensions (D, H, W) are approximately ⅓ in. (3mm) undersize. (All 'H' dimensions larger than single section height are two sections high. Refer to chart.)

Type R

Inches (mm)	Type R*		
	Minimum	Maximum with 1 in. offset	Maximum with 2 in. offset
Single Section Vertical	3 (76)	35 (889)	34 (864)
Multi Section Vertical**	NA	59 (1499)	58 (1473)
Single Section Horizontal	3 (76)	29 (737)	28 (711)
Multi Section Horizontal**	NA	35 (889)	34 (864)

* Sizes are based on 165°F closure temperature and 2000 fpm. Consult factory for maximum size for different temperatures and velocities.

** Consult factory for number of sections.

Overall Damper Dimensions

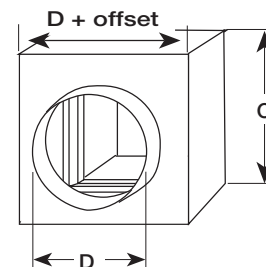

Type R transition is centered in damper sleeve.

To calculate O Dimension:

Diameter + offset (1 or 2 in.) = O Dimension

