

Adjustable Louver J Blade

Application and Design

EAH-401 is an adjustable louver designed to protect air intake and exhaust openings in building exterior walls. Design incorporates a drainable head member, adjustable J style blades and high free area to provide maximum resistance to rain while providing minimum resistance to airflow. The EAH-401 is an extremely efficient louver with **AMCA LICENSED PERFORMANCE DATA** enabling designers to select and apply with confidence.

Standard Construction

- Frame** Heavy gauge extruded 6063-T5 aluminum, 4 in. x 0.125 in. nominal wall thickness
- Blades** J style design, heavy gauge extruded 6063-T5 aluminum, 0.081 in. nominal wall thickness, positioned at 45° angles on approximately 4 in. centers
- Seals** Dual-durometer extruded vinyl blade seals
Compressible stainless steel jamb seals
- Temperature Restrictions** . . . (-20° F) - (+180° F)
- Linkage** Side linkage, out of airstream (concealed in frame)
- Bearings** Synthetic sleeve type
- Axles** ½ in. dia. zinc plated steel
- Construction** . . . Mechanically fastened
- Birdscreen** ¾ in. x 0.051 in. flattened expanded aluminum in removable frame, inside mount (rear)
- Finish** Mill
- Minimum Size** . . 12 in. W x 12 in. H
- Maximum Single Section Size** . . . 60 in. W x 96 in. H

Options (at additional cost)

- A variety of bird and insect screens
- A variety of electric, pneumatic or manual actuators
- Clip angles
- Extended sill
- Filter rack
- Flanged frame
- Glazing adaptor
- Security bars
- A variety of architectural finishes including:
 - Clear anodize
 - Integral color anodize
 - Baked enamel paint
 - Kynar paint

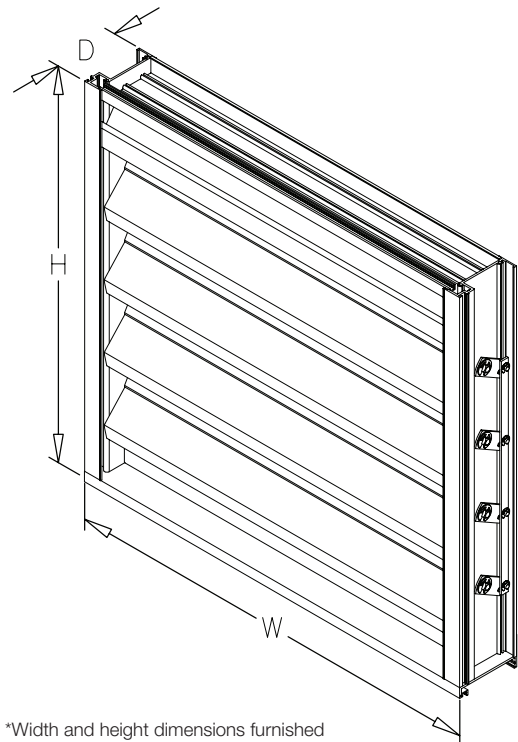
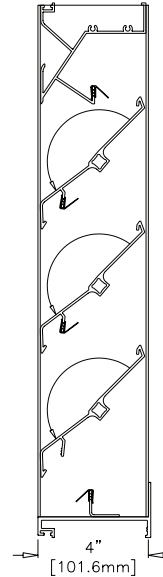

*Width and height dimensions furnished approximately ¼ inch under size.

PERFORMANCE DATA

EAH-401

Adjustable Louver J Blade
Extruded Aluminum

Free Area Chart (Sq. ft.)

Louver Height Inches	Louver Width in Inches																
	12	15	18	21	24	27	30	33	36	39	42	45	48	51	54	57	60
16	0.28	0.38	0.47	0.59	0.65	0.75	0.84	0.93	1.02	1.11	1.21	1.30	1.39	1.48	1.57	1.67	1.76
21	0.43	0.57	0.71	0.85	0.99	1.13	1.28	1.42	1.56	1.70	1.84	1.98	2.12	2.26	2.40	2.54	2.68
30	0.73	0.97	1.20	1.44	1.68	1.91	2.15	2.39	2.63	2.86	3.10	3.34	3.57	3.81	4.05	4.28	4.52
33	0.88	1.16	1.45	1.73	2.02	2.30	2.59	2.87	3.16	3.44	3.73	4.01	4.30	4.59	4.87	5.15	5.44
42	1.18	1.56	1.94	2.32	2.70	3.08	3.47	3.85	4.23	4.61	4.99	5.37	5.75	6.14	6.54	6.90	7.28
48	1.33	1.75	2.18	2.61	3.04	3.47	3.90	4.33	4.76	5.19	5.62	6.05	6.48	6.91	7.34	7.77	8.20
57	1.62	2.15	2.67	3.20	3.73	4.25	4.78	5.31	5.83	6.36	6.88	7.41	7.94	8.46	8.99	9.52	10.04
60	1.77	2.35	2.92	3.49	4.07	4.64	5.22	5.79	6.37	6.94	7.52	8.09	8.66	9.24	9.81	10.39	10.96
69	2.07	2.74	3.41	4.08	4.75	5.42	6.09	6.77	7.44	8.11	8.78	9.45	10.12	10.79	11.46	12.13	12.80
75	2.22	2.94	3.66	4.37	5.09	5.81	6.53	7.25	7.97	8.69	9.41	10.13	10.85	11.57	12.29	13.00	13.72
84	2.51	3.33	4.15	4.96	5.78	6.59	7.41	8.22	9.04	9.86	10.67	11.49	12.30	13.12	13.93	14.75	15.56
87	2.66	2.53	4.39	5.25	6.12	6.98	7.85	8.71	9.57	10.44	11.30	12.17	13.03	13.89	14.76	15.62	16.48
96	2.96	3.92	4.88	5.84	6.80	7.76	8.72	9.68	10.64	11.60	12.56	13.52	14.48	15.44	16.40	17.37	18.33

Air Leakage (with damper section closed) Test size 48 in. x 48 in.

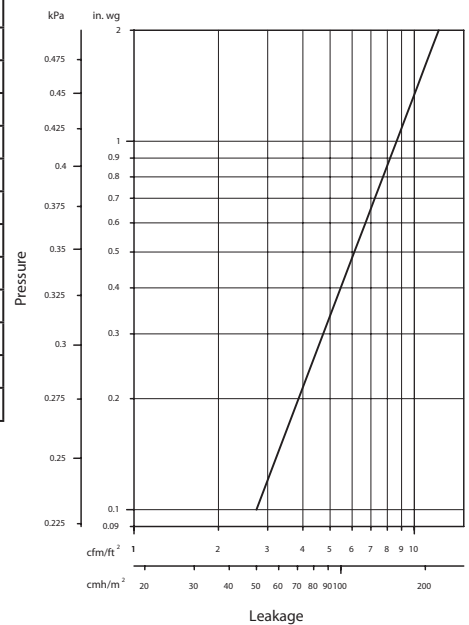



Greenheck Fan Corporation certifies that the EAH-401 louvers shown herein are licensed to bear the AMCA Seal. The ratings shown are based on tests and procedures performed in accordance with AMCA Publication 511 and comply with the requirements of the AMCA Certified Ratings Program. The AMCA Certified Ratings Seal applies to air performance and water penetration ratings.

Airflow Resistance (Standard Air - .075 lb/ft³)

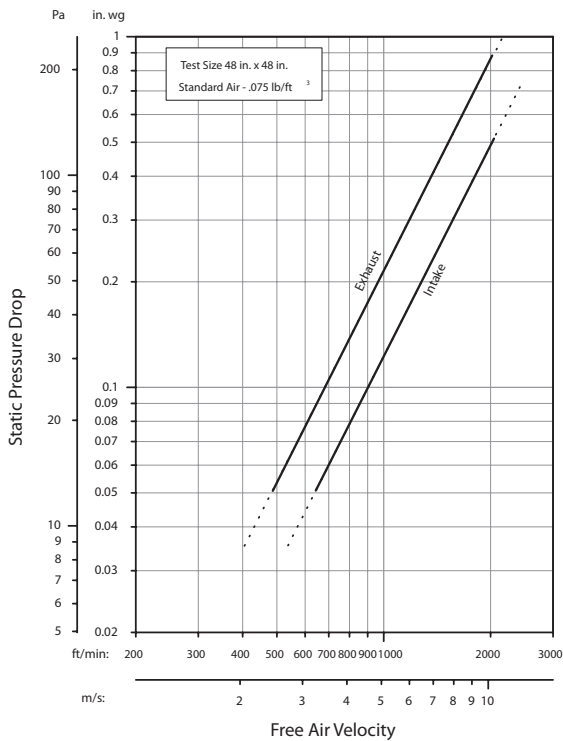

Model EAH-401 resistance to airflow (pressure drop) varies depending on louver application (air intake or air exhaust). Free area velocities (shown) are higher than average velocity through the overall louver size. See louver selection information.

Water Penetration (Standard Air - .075 lb/ft³)

Test size 48 in. x 48 in. Test duration of 15 min.

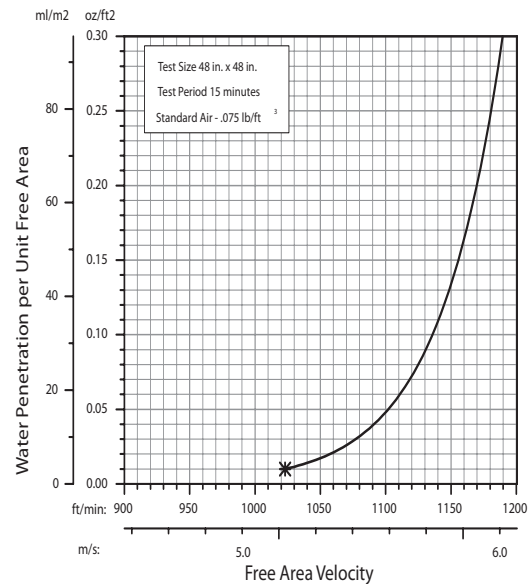

The AMCA Water Penetration Test provides a method for comparing various louver models and designs as to their efficiency in resisting the penetration of rainfall under specific laboratory test conditions. The beginning point of water penetration is defined as that velocity where the water penetration curve projects through .01 oz. of water (penetration) per sq. ft. of louver free area. ***The beginning point of water penetration for Model EAH-401 is 1023 fpm free area velocity.** These performance ratings do not guarantee a louver to be weatherproof or stormproof and should be used in combination with other factors including good engineering judgement in selecting louvers.



INSTALLATION DETAILS

EAH-401

Maximum Size and Installation Information

Adjustable Louver J Blade
Extruded Aluminum

Maximum single section size for model EAH-401 is 60 in. W x 96 in. H. Larger openings require field assembly of multiple louver sections to make up the overall opening size. Individual louver sections are designed to withstand a 25 PSF wind load (please consult Greenheck if the louvers must withstand higher wind-loads). Structural reinforcing members may be required to adequately support and install multiple louver sections within a large opening. Structural reinforcing members along with any associated installation hardware is not provided by Greenheck unless indicated otherwise by Greenheck. Options and accessories including, but not limited to, screens, filter racks, louver doors, and blank off panels are not subject to structural analysis unless indicated otherwise by Greenheck. Additional information on louver installation may be found in AMCA Publication #501, Louver Application Manual.

SINGLE SECTION

MULTIPLE SECTION W/ MULLION

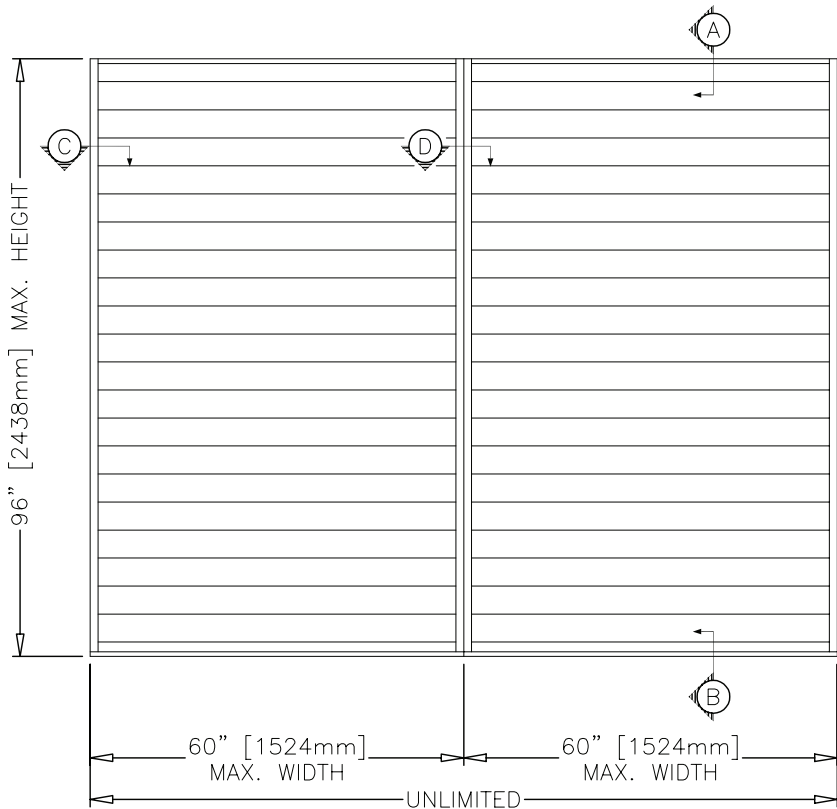
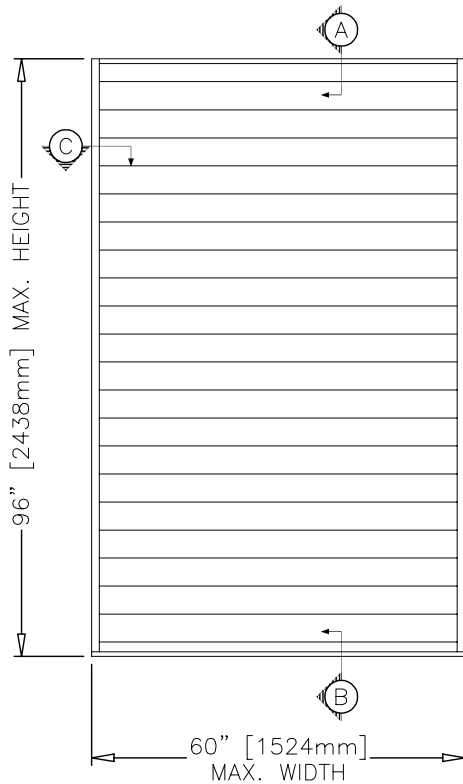

Minimum Single Section Size

12 in. W x 12 in. H

Maximum Single Section Size

60 in. W x 96 in. H

PRODUCT DETAILS

EAH-401

Adjustable Louver J Blade
Extruded Aluminum

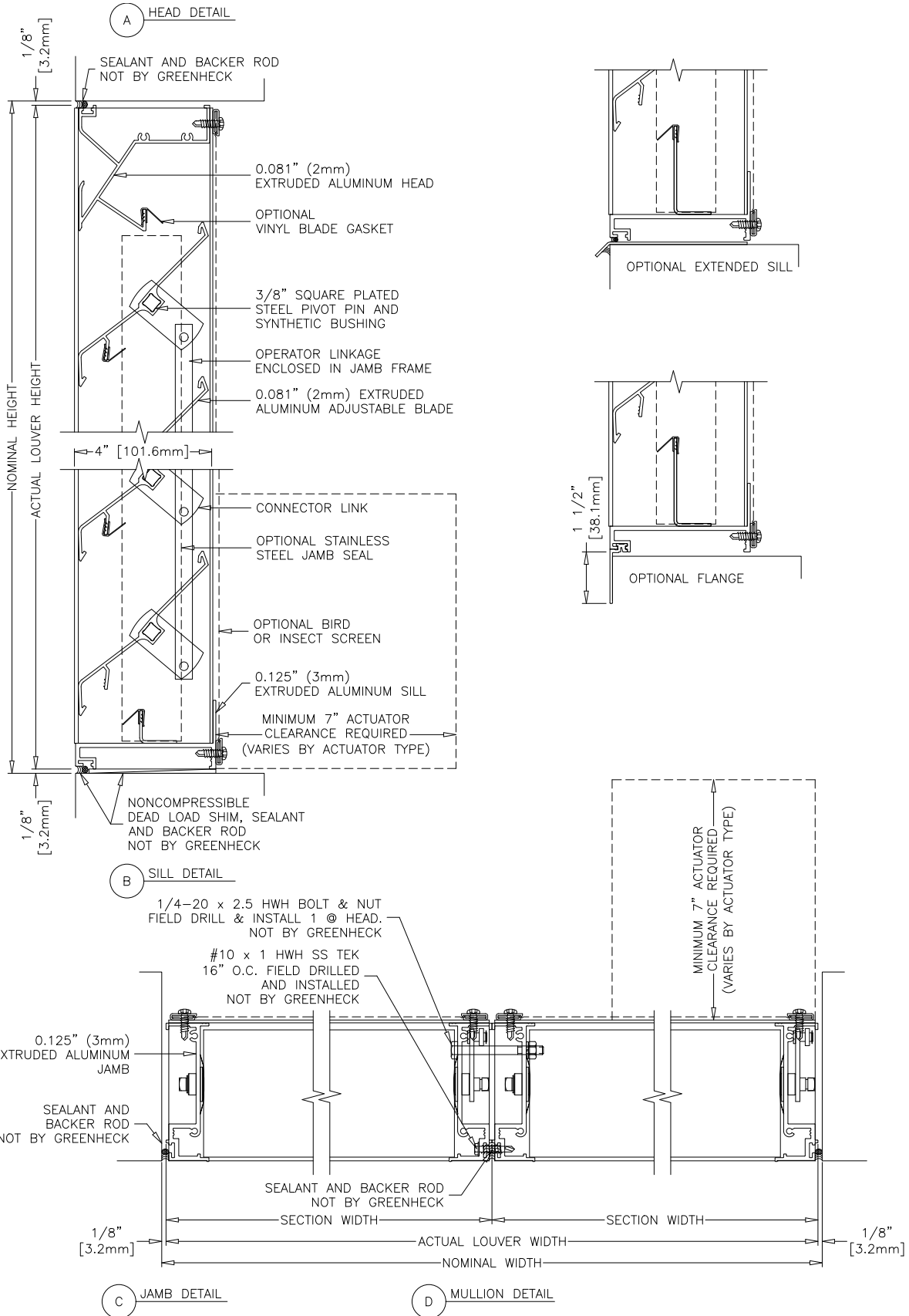

OPTION DRAWINGS

EAH-401

Adjustable Louver J Blade Extruded Aluminum

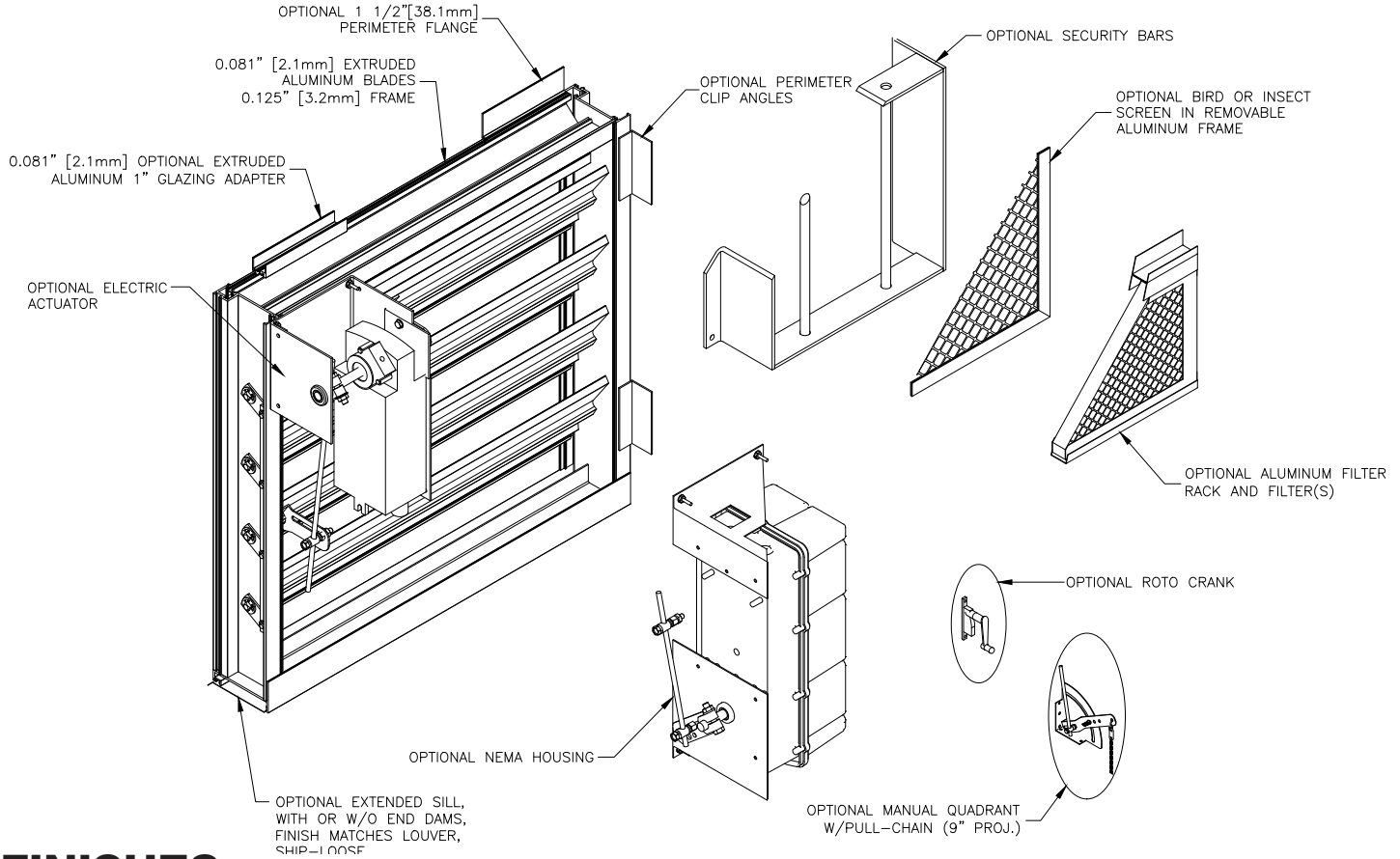

FINISHES

Finish Type	Description/Application	Color Selection	Standard Warranty (Aluminum)
AAMA 2605 100% Fluoropolymer (FEVE) 2-Coat 70% Kynar® (PVDF) 3-Coat 70% Kynar® (PVDF) 4-Coat 70% Kynar® (PVDF)	"Best." The premier finish for extruded aluminum. Tough, long-lasting coating has superior color retention and abrasive properties. Resists chalking, fading, chemical abrasion and weathering.	Standard Colors: Any of the 27 standard colors shown can be furnished in 70% or 50% Kynar®, 100% Fluoropolymer or Baked Enamel.	10 Years (20 Years Optional)
AAMA 2604 50% Kynar® / Acroflur®	"Better." Tough, long-lasting coating has excellent color retention and abrasive properties. Resists chalking, fading, chemical abrasion and weathering.	Mica Colors: Greenheck offers 6 standard Mica colors for 70% Kynar® or 100% Fluoropolymer.	5 Years
AAMA 2603 Baked Enamel	"Good." Provides good adhesion and resistance to weathering, corrosion and chemical stain.	Custom Colors: Custom color matching is available. Consult your Greenheck representative for cost and/or lead-time implications if a custom color is required.	1 Year
AA-M10C22A42 Integral Color Anodize	"Two-step" anodizing is produced by following the normal anodizing step with a second, colorfast process.	Light, Medium, Dark or Extra Dark Bronze; Champagne; Black	5 years
AA-M10C22A41 Clear Anodize 215 R-1	Clear, colorless and hard oxide aluminum coating that resists weathering and chemical attack.	Clear	5 years
AA-M10C22A31 Clear Anodize 204	Clear, colorless and hard oxide aluminum coating that resists weathering and chemical attack.	Clear	1 Year
Prime Coat	Louvers or architectural products shall be cleaned, pre-treated and receive a prime coat finish suitable for field painting. Greenheck does not recommend prime coat or field painting of materials.		n/a
Mill	Materials may be supplied in natural aluminum or galvanized steel finish when normal weathering is acceptable and there is no concern for color or color change.		n/a

Finishes meet or exceed AAMA 2605, AAMA 2604, and AAMA 2603 requirements. Please consult www.greenheck.com for complete information on standard and extended paint warranties. Paint finish warranties are not applicable to steel products.

