

Florida Product Approval No.: FL11350.1
 Miami-Dade, FL NOA No.: 23-0425.02, EXP. 7/19/2028

Standard Construction

Frame	Heavy gauge extruded 6063-T5 aluminum, 6 in. (152 mm) x 0.081 in. (2 mm) nominal wall thickness
Blades	Horizontal rain resistant design, heavy gauge extruded 6063-T5 aluminum, 0.081 in. (2 mm) nominal wall thickness, positioned on approximately 2 in. (51 mm) centers
Construction	Welded
Finish	Mill
Minimum Throat Size	12 in. W x 12 in. L (305 mm W x 305 mm L)
Maximum Throat Size	84 in. W x 108 in. L (2134 mm W x 2743 mm L)
Minimum Louver Height	12 in. (305 mm)
Minimum Louver Height	84 in. (2134 mm)
Wind Load	+/- 115 PSF (5.5 kPa)

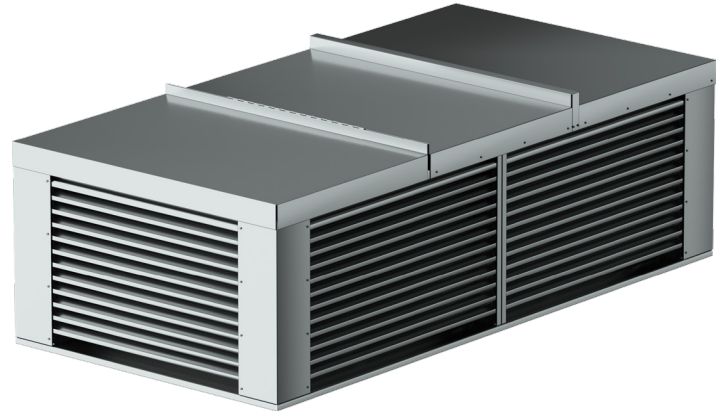

Application and Design

EHH-601PD is a gravity intake or exhaust louvered penthouse. Model EHH-601PD incorporates high performance horizontal wind-driven rain style blades for maximum protection against wind-driven rain. Meets the performance requirements established by the Florida Building Code and Miami-Dade County. Tested in accordance with and passes TAS 201 (Large Missile Impact), TAS 202 (Uniform Static Air Pressure) and TAS 203 (Cyclic Wind-Loading). This system should be installed in a location where the enclosed area/room inside the penthouse is designed to drain water penetrating into the area/room, and the area/room will house water resistant/proof equipment, components and/or supplies. Roof curbs specifically designed for model EHH-601PD may be supplied by Greenheck as an option. Qualified for installation onto concrete/masonry, steel stud, structural steel or wood substrate. Model EHH-601PD may also be supplied as an equipment enclosure without hood members.

Document Links

[Louver Finishes & Colors](#)
[Louver Product Selection Guide](#)
[Louver Products Catalog](#)
[Louver Warranty Statement](#)

Options and Accessories

- [Bird Screen](#)
- [Blank-off Panels](#)
- [Filter Rack/Filter](#)
- Hood
- Hood Insulation
- [Insect Screen](#)
- Roof Curb - flat or pitched
- [Security Bars](#)
- [Variety of Architectural Finishes](#)

Product Details

[Miami-Dade County, FL Notice of Acceptance](#)

PERFORMANCE DATA

EHH-601PD

Miami-Dade and Florida Product Approved
Extruded Aluminum, Louvered Penthouse

Performance data shown herein is a result of in-house airflow resistance testing procedures in an AMCA Accredited Laboratory. The static pressure drops shown at given throat velocities include the pressure drop through the throat of the product as well as through the louvers themselves. The recommended height shown herein allows for equal to or greater than effective louver free area to that of the penthouse inside throat area. Increasing the product height will have minimal affect on the static pressure drop. The static pressure drops shown do not include the effects of bird screen, insect screen or any other appurtenance.

Throat W x L in. mm	Recommended Louver Height in. mm	Louver Throat Area sq. ft. sq. m	Intake CFM CMS			Exhaust CFM CMS			
			Pressure Drop in. wg kPa			Pressure Drop in. wg kPa			
			0.082	0.185	0.333	0.037	0.086	0.152	0.239
			0.020	0.046	0.083	0.009	0.021	0.038	0.059
			Intake Throat Velocities			Exhaust Throat Velocities			
			400 fpm 0.189 mps	600 fpm 0.283 mps	800 fpm 0.378 mps	400 fpm 0.189 mps	600 fpm 0.283 mps	800 fpm 0.378 mps	1000 fpm 0.472 mps
12 x 12 305 x 305	12 305	0.8 0.07	320 0.15	480 0.23	640 0.30	320 0.15	480 0.23	640 0.30	800 0.38
12 x 24 305 x 610	16 406	1.8 0.17	720 0.34	1,080 0.51	1,440 0.68	720 0.34	1,080 0.51	1,440 0.68	1,800 0.85
24 x 24 610 x 610	16 406	3.7 0.34	1,480 0.70	2,220 1.05	2,960 1.40	1,480 0.70	2,220 1.05	2,960 1.40	3,700 1.75
24 x 48 610 x 1219	20 508	7.5 0.70	3,000 1.42	4,500 2.12	6,000 2.83	3,000 1.42	4,500 2.12	6,000 2.83	7,500 3.54
36 x 36 914 x 914	20 508	8.5 0.79	3,400 1.60	5,100 2.41	6,800 3.21	3,400 1.60	5,100 2.41	6,800 3.21	8,500 4.01
36 x 72 914 x 1829	24 610	17.3 1.61	6,920 3.27	10,380 4.90	13,840 6.53	6,920 3.27	10,380 4.90	13,840 6.53	17,300 8.16
48 x 48 1219 x 1219	24 610	15.3 1.42	6,120 2.89	9,180 4.33	12,240 5.78	6,120 2.89	9,180 4.33	12,240 5.78	15,300 7.22
48 x 96 1219 x 2438	32 813	31.0 2.88	12,400 5.85	18,600 8.78	24,800 11.70	12,400 5.85	18,600 8.78	24,800 11.70	31,000 14.63
60 x 60 1524 x 1524	28 711	24.2 2.25	9,680 4.57	14,520 6.85	19,360 9.14	9,680 4.57	14,520 6.85	19,360 9.14	24,200 11.42
62 x 86 1575 x 2184	44 1118	25.8 2.40	10,320 4.87	15,480 7.31	20,640 9.74	10,320 4.87	15,480 7.31	20,640 9.74	25,800 12.18
60 x 108 1524 x 2743	36 914	43.8 4.07	17,520 8.27	26,280 12.40	35,040 16.54	17,520 8.27	26,280 12.40	35,040 16.54	43,800 20.67
72 x 72 1829 x 1829	32 813	35.0 3.25	14,000 6.61	21,000 9.91	28,000 13.21	14,000 6.61	21,000 9.91	28,000 13.21	35,000 16.52
72 x 96 1829 x 2438	40 1016	46.8 4.35	18,720 8.83	28,080 13.25	37,440 17.67	18,720 8.83	28,080 13.25	37,440 17.67	46,800 22.09
84 x 84 2134 x 2134	40 1016	47.8 4.44	19,120 9.02	28,680 13.54	38,240 18.05	19,120 9.02	28,680 13.54	38,240 18.05	47,800 22.56
84 x 96 2134 x 2438	40 1016	54.8 5.09	21,920 10.35	32,880 15.52	43,840 20.69	21,920 10.35	32,880 15.52	43,840 20.69	54,800 25.86
84 x 108 2134 x 2743	44 1118	61.7 5.73	24,680 11.65	37,020 17.47	49,360 23.30	24,680 11.65	37,020 17.47	49,360 23.30	61,700 29.12

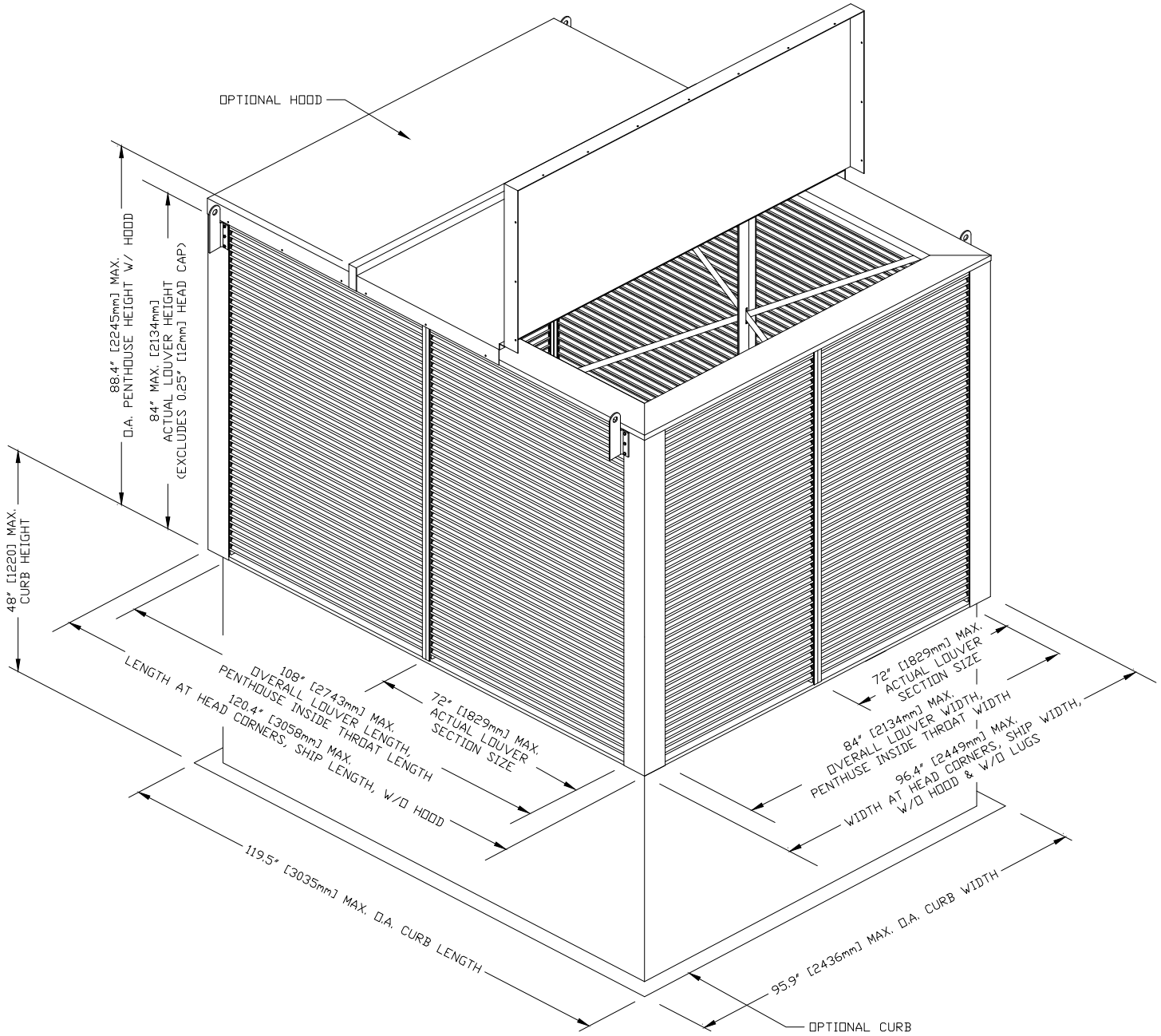

DETAILS

SINGLE SECTION-WITHOUT HOOD

EHH-601PD

Miami-Dade and Florida Product Approved
Extruded Aluminum, Louvered Penthouse

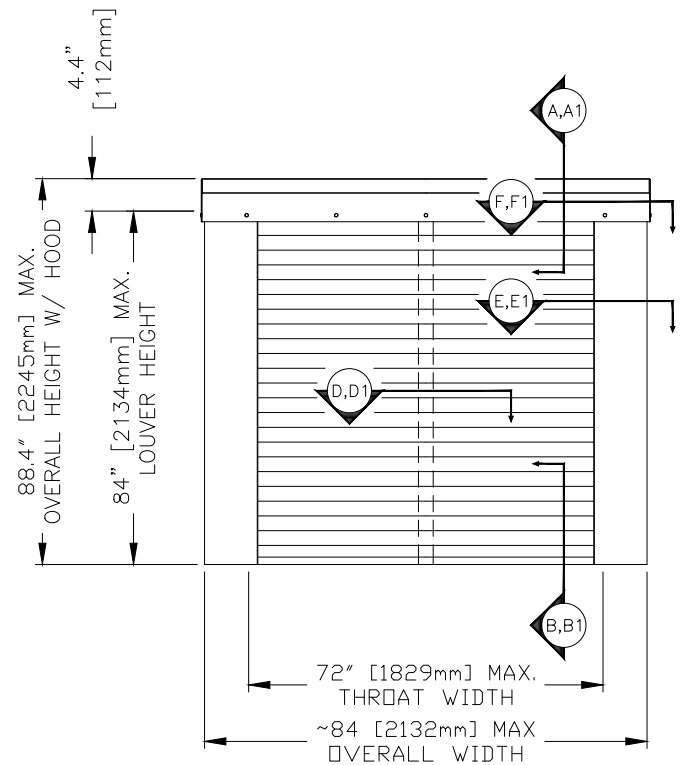
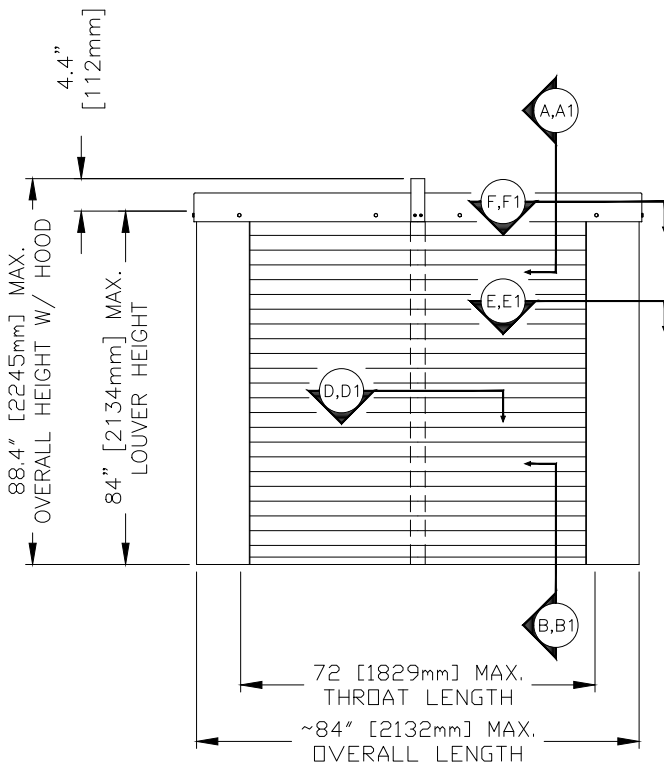
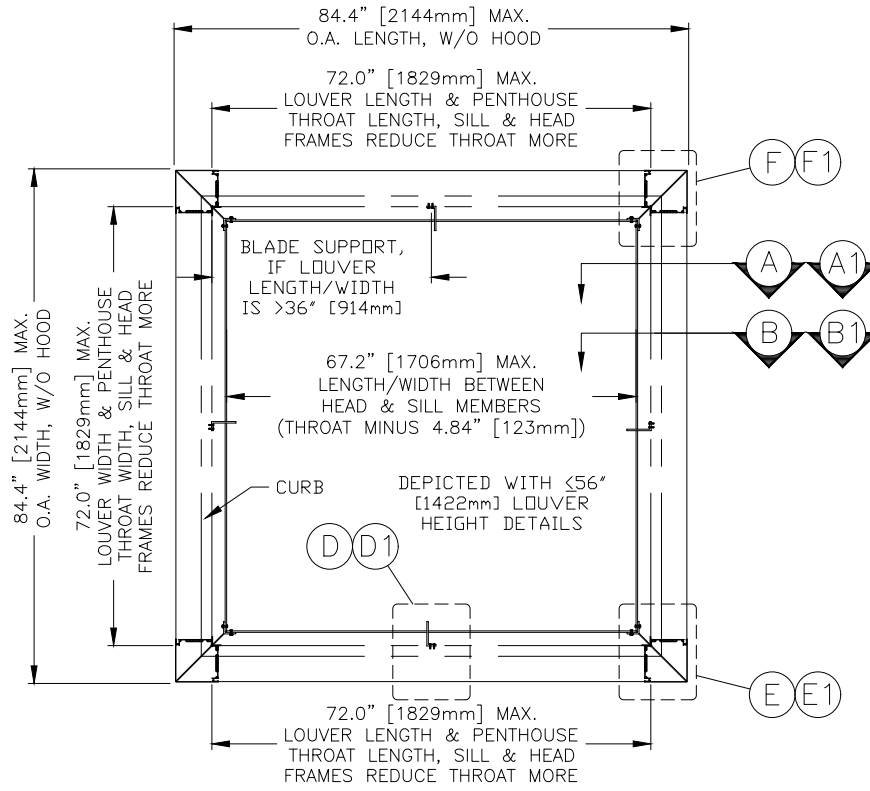

DETAILS

TWO SECTION-WITHOUT HOOD

EHH-601PD

Miami-Dade and Florida Product Approved
Extruded Aluminum, Louvered Penthouse

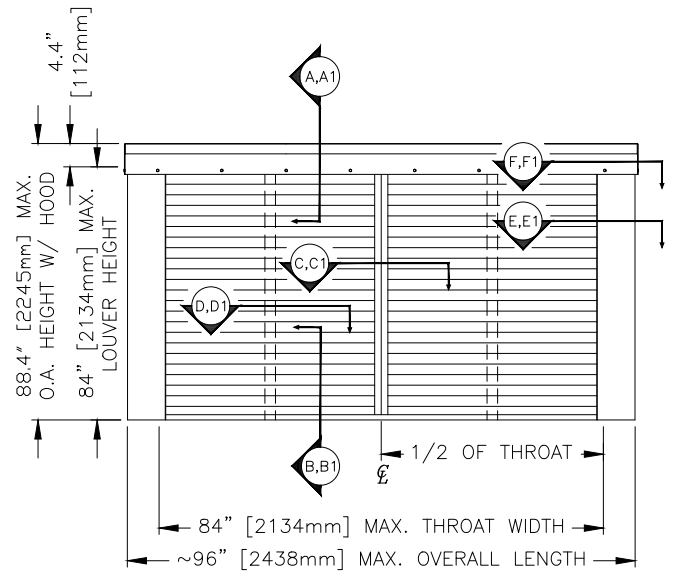
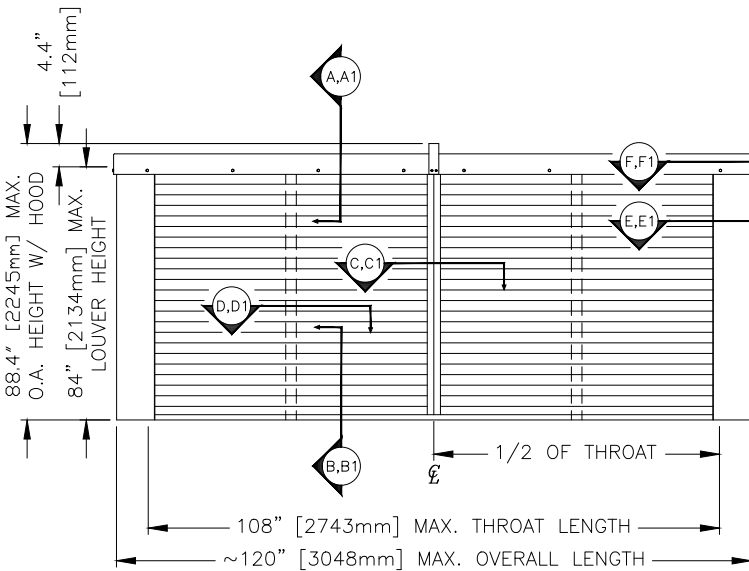
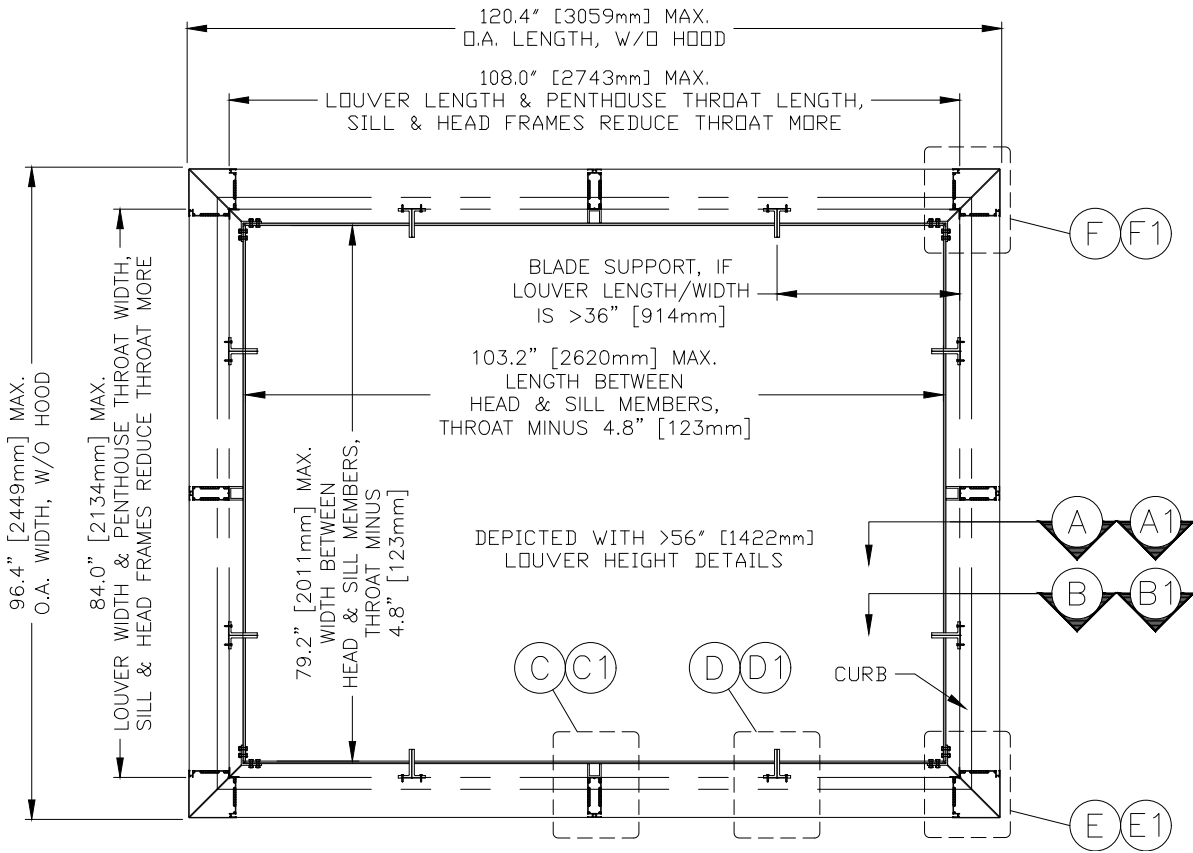

LESS THAN OR EQUAL TO 56 IN. (1142 MM) HEIGHT

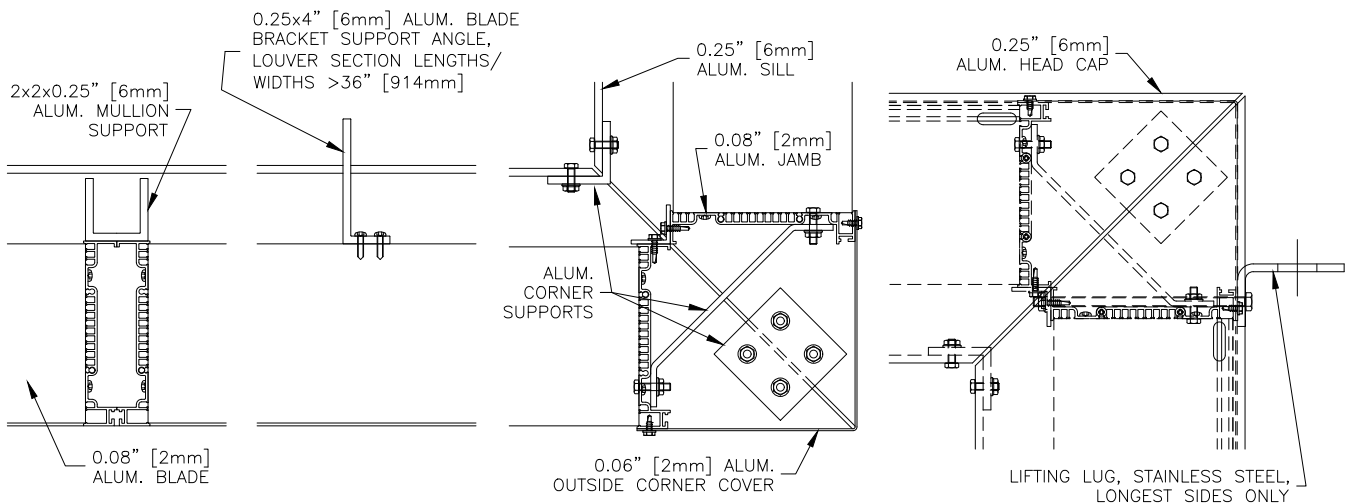
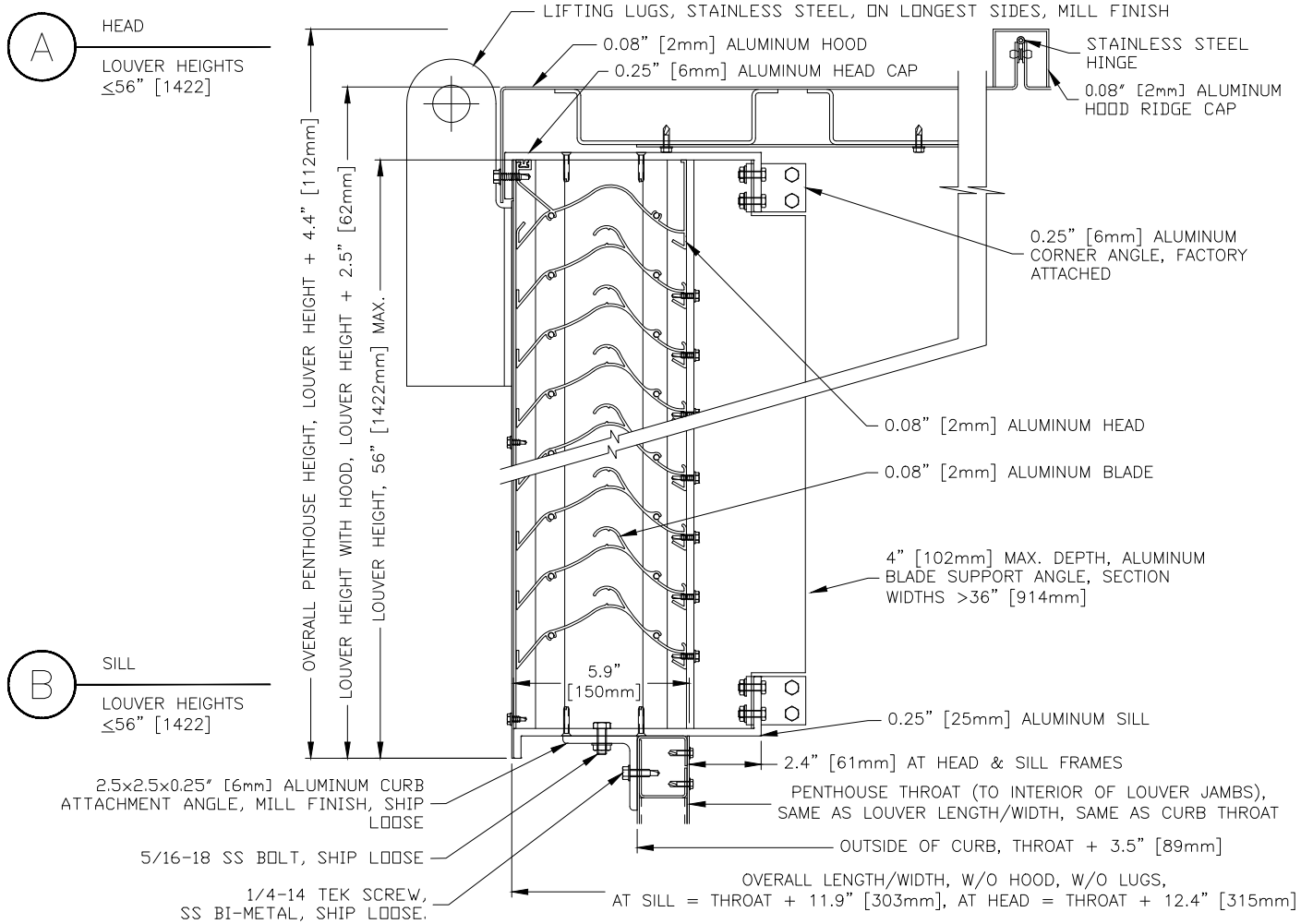

C MULLION
LOUVER HEIGHTS ≤56" [1422mm]

D BLADE SUPPORT
LOUVER HEIGHTS ≤56" [1422mm]

E SILL CORNER
LOUVER HEIGHTS ≤56" [1422mm]

F HEAD CORNER
LOUVER HEIGHTS ≤56" [1422mm]

GREATER THAN 56 IN. (1142 MM) HEIGHT

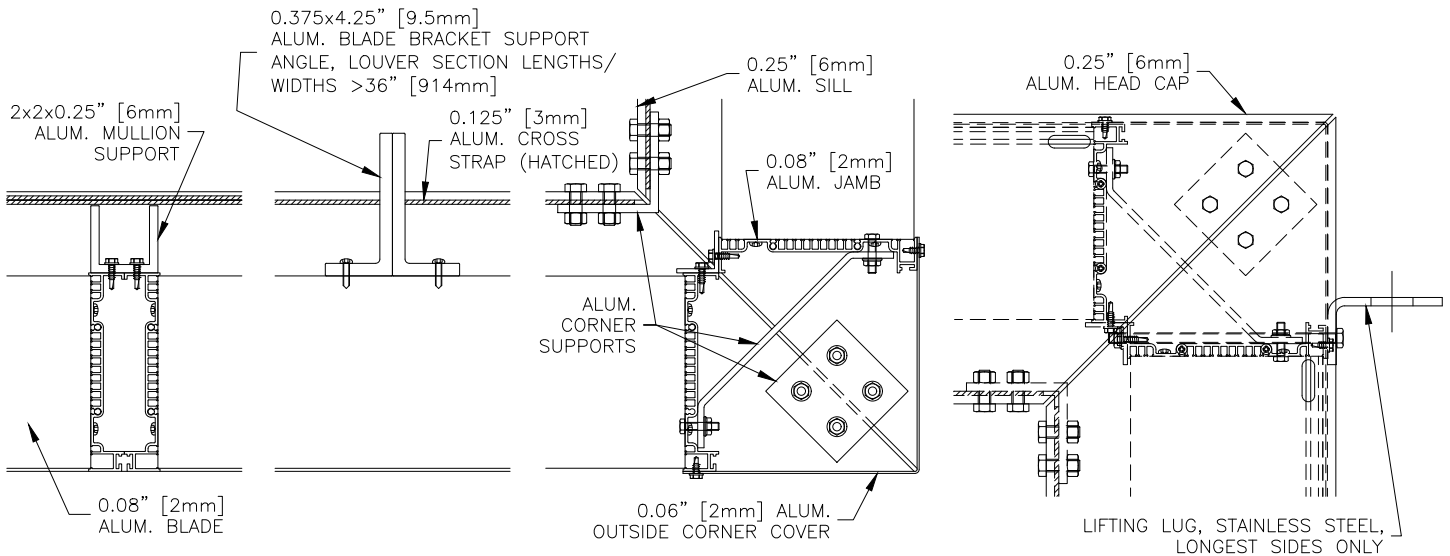
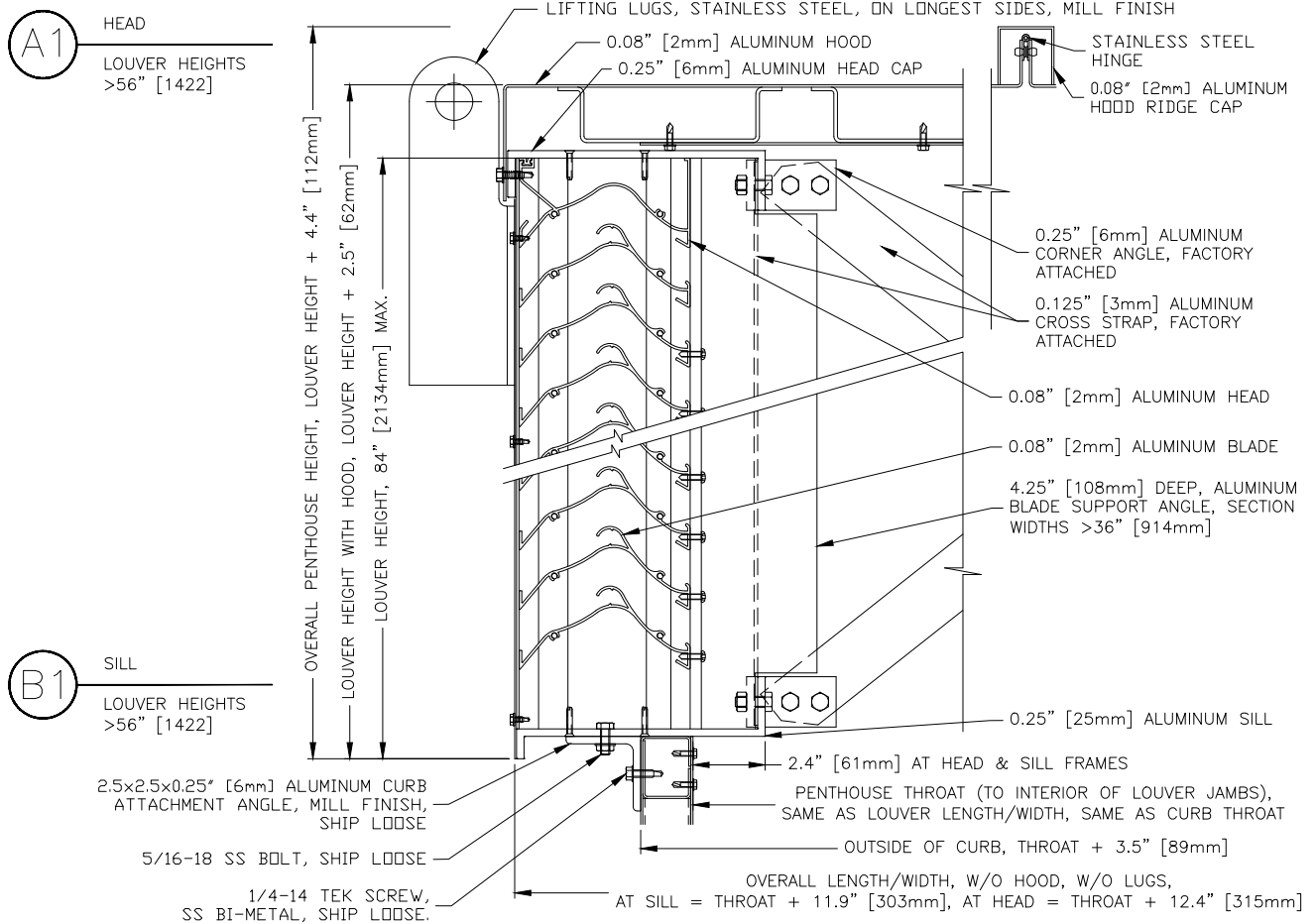

C1 MULLION
LOUVER HEIGHTS >56" [1422mm]

D1 BLADE SUPPORT
LOUVER HEIGHTS >56" [1422mm]

E1 SILL CORNER
LOUVER HEIGHTS >56" [1422mm]

F1 HEAD CORNER
LOUVER HEIGHTS >56" [1422mm]

CURB DETAILS

EHH-601PD

Miami-Dade and Florida Product Approved
Extruded Aluminum, Louvered Penthouse

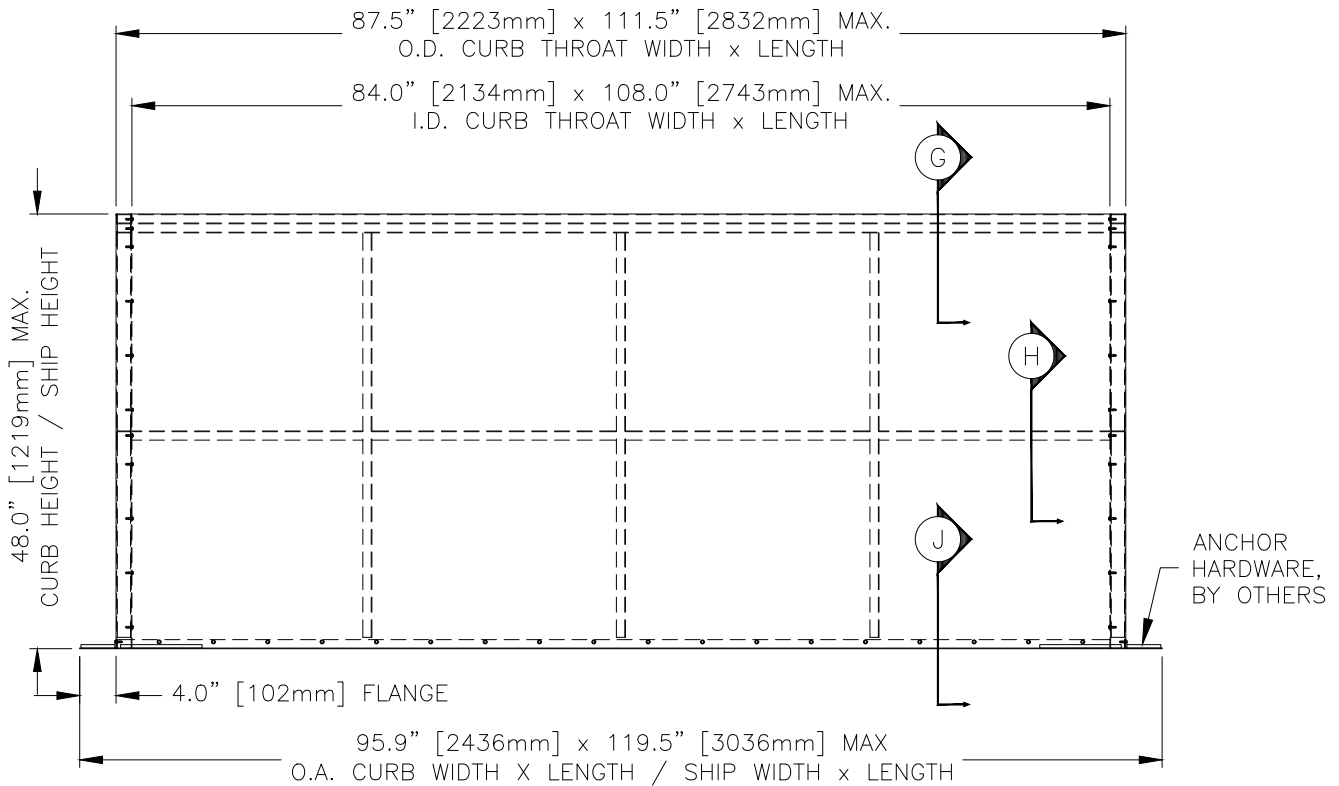

G CURB DETAILS TOP

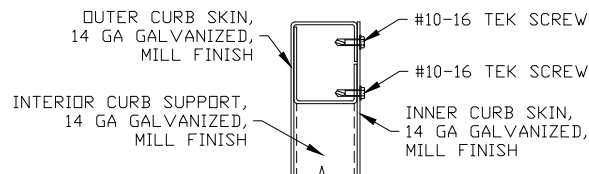

H CURB DETAILS MIDDLE

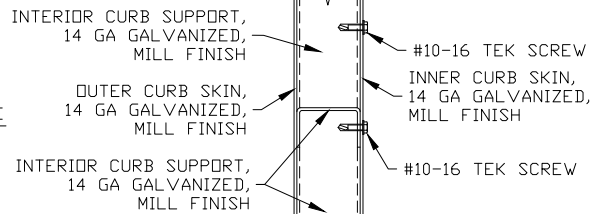

J CURB DETAILS BOTTOM

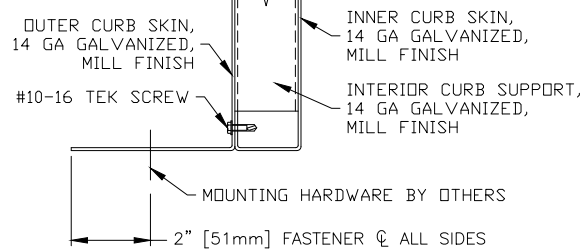

ROOF OPENING DETAILS

EHH-601PD

Miami-Dade and Florida Product Approved
Extruded Aluminum, Louvered Penthouse

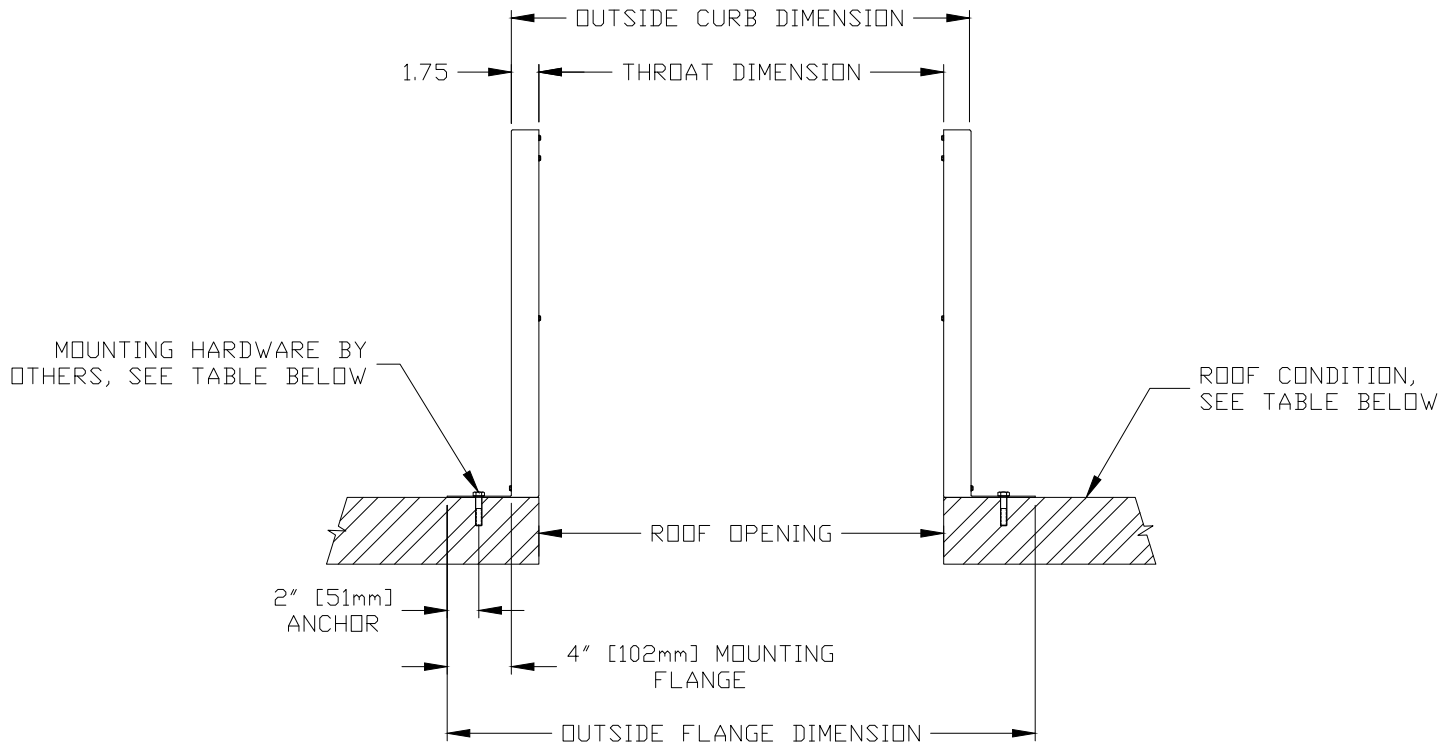

CURB ANCHOR INFORMATION		
SUBSTRATE, MINIMUMS	ANCHOR DESCRIPTION	NOTES
CONCRETE: 4" [102mm] THICK 3 KSI [20.6 MPA] NORMAL WEIGHT CRACKED	HILTI KWIK BOLT TZ2 EXPANSION ANCHOR, 300 SS, 6" [152mm] MAX CENTERS ALONG CURB FLANGE, $\phi 3/8"$ [10mm] ONLY X MIN LENGTH \square 3" [76mm]	MIN 2.5" NOM. EMBEDMENT, MIN 4.38" [111mm] TO CONCRETE EDGE/END, FULL BEARING REQUIRED UNDER CURB FLANGE, ALSO ACCEPTABLE IS 300 SS THRU-BOLT MIN 3/8-16 WITH MIN 2" [51mm] O.D. BY MIN 0.05" [1.3mm] THICK WASHER AT NUT
	HILTI KWIK BOLT TZ2 EXPANSION ANCHOR, 300 SS. 2 PER CORNER ANCHOR PLATE AT 6" [152mm] MAX CENTERS, $\phi 3/8"$ [10mm] ONLY X MIN LENGTH \square 3.5" [89mm]	
STEEL: 16 GA [1.6mm] FY 50 KSI [345 MPA] OR 1/8" [3mm] ASTM A3, FY 36 KSI [248 MPA]	ELCO BI-FLEX SELF-DRILLING SCREW, 3" [76mm] MAX CENTERS ALONG CURB FLANGE, MIN 1/4-(14 OR 20) X 1" MIN LENGTH	FULL THREAD ENGAGEMENT, MIN 0.5" [13mm] STEEL EDGE/END, 300 SS HEAD/SHANK WITH COATED STEEL DRILL POINT, FULL BEARING REQUIRED UNDER CURB FLANGE, ALSO ACCEPTABLE IS 300 SS THRU-BOLT MIN 1/4-20 WITH MIN 0.5" [13mm] O.D. BY MIN 0.04" [1mm] THICK WASHER AT NUT
	ELCO BI-FLEX SELF-DRILLING SCREW, 9 PER CORNER ANCHOR PLATE AT 0.75" [19mm] MAX CENTERS, MIN 1/4-(14 OR 20) X 1.5" MIN LENGTH	
WOOD: 3" [76mm] THICKNESS, S.G. 0.042	LAG BOLT, 300 SS, 3" [76mm] MAX CENTERS ALONG CURB FLANGE, MIN $\phi 1/2"$ X 3" MIN LENGTH	MIN 2" [51mm] THREAD ENGAGEMENT, MIN 2.9" [74mm] PENETRATION, MIN 1.5" [38mm] WOOD EDGE, MIN 2.63" [67mm] WOOD END, FULL BEARING REQUIRED UNDER CURB FLANGE, ALSO ACCEPTABLE IS 300 SS THRU-BOLT MIN 1/2-13 WITH MIN 2" [51mm] O.D. BY MIN 0.05" [1.3mm] THICK WASHER AT NUT
	LAG BOLT, 300 SS, 3 PER CORNER ANCHOR PLATE AT 3" [76mm] MAX CENTERS, MIN $\phi 1/2"$ X 3.5" MIN LENGTH	

OPTION DRAWINGS

EHH-601PD

Miami-Dade and Florida Product Approved
Extruded Aluminum, Louvered Penthouse

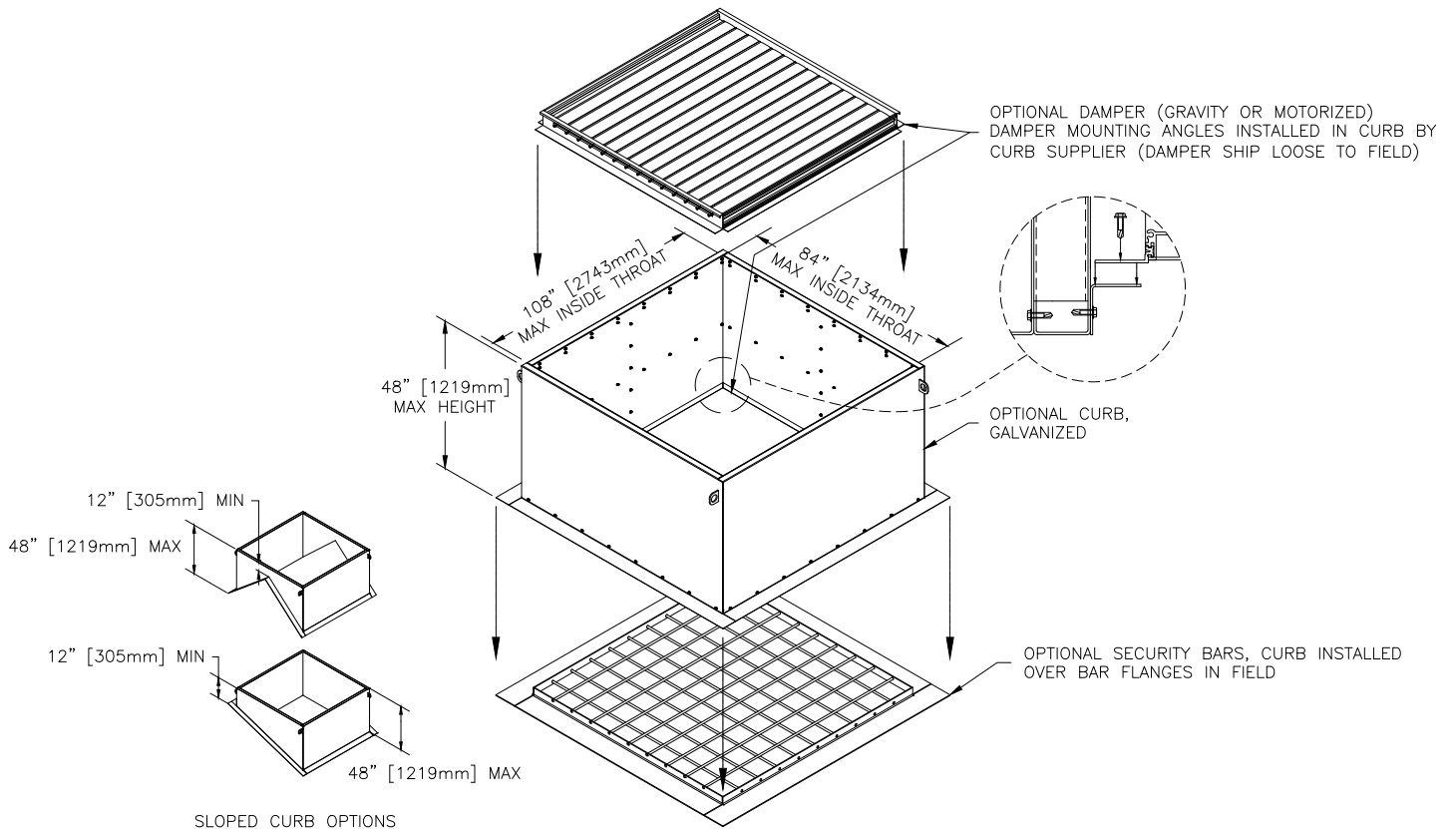

Weather Infiltration Disclosure

Louvered penthouses provide a level of defense against weather infiltration, however; louvered penthouses cannot be considered weather proof. Greenheck recommends provisions to manage weather infiltration be present beyond the louvered penthouse so as to mitigate weather passage and prevent water related damage to building conditions or equipment. Design of or materials as required to manage weather infiltration are not provided by Greenheck. Greenheck also recommends sound product application/engineering practice(s) be employed when applying louvered penthouses. Such practice(s) may include, but are not limited to, conservative throat and louver free area velocities. Greenheck shall not be held liable for water related damage to building conditions or equipment

