

Application

Model FD-150 is a static rated fire damper approved for use in floors, walls, and partitions with fire resistance ratings less than 3 hours. This model carries a 1½ hour UL 555 fire damper label and is static rated for use in HVAC systems that are automatically shut down in the event of fire.

Ratings

UL 555 Fire Resistance Rating

Fire Rating: 1½ hours

Construction

	Standard	Optional
Frame Material	Galvanized steel*	-
Frame Depth	3 ¹¹ / ₁₆ in. (94mm)	-
Blade Material	Galvanized steel*	-
Closure Spring	Stainless steel	-
Fusible Link	165°F (74°C)	212°F (100°C)
Mounting	Vertical	Horizontal

* in gauges required by UL listing R13317



* These dimensions are furnished approximately ¼ in. (6mm) undersize.



See complete marking on product.
UL 555 Classification R13317

Model FD-150 meets the requirements for fire dampers established by:

National Fire Protection Association

(NFPA Standards 80, 90A & 101)

Underwriters Laboratories Standard 555

(Listing #R13317)

IBC International Building Codes

California State Fire Marshall

(Listing #3225-981:102)

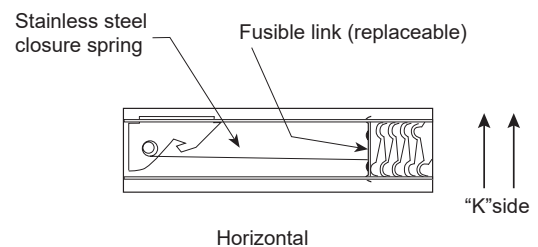
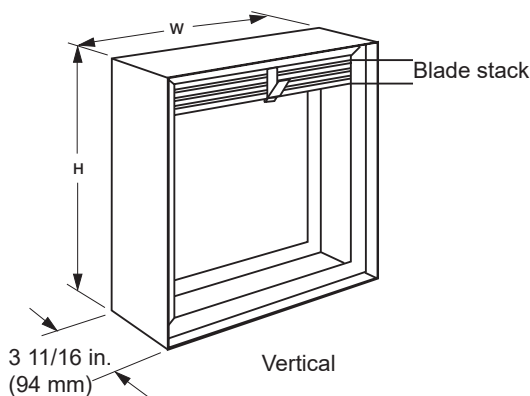

Options and Accessories

- [Breakaway connections](#)
- Clean wrap
- Closed indicator switch
- Flanges
- [Grille tabs](#)
- [Retaining angles](#)
- Sealed transitions and sleeve
- Transitions: B, B2, C, CO, CR, and R

Document Links



[INSTALLATION](#)



[CATALOG](#)



[SELECTION GUIDE](#)



[SPECIFICATIONS](#)



[WARRANTY](#)



[INSTALLATION SOLUTIONS](#)

Factory Sleeve Option

All fire damper installations require the use of sleeves, angles and methods described in the installation instructions. Sleeves can be field fabricated or factory furnished as a completed damper/sleeve assembly.

Sleeves are galvanized steel and are available in 20 through 10 ga. (1mm - 3.5mm) thicknesses and lengths up to 36 in. (914mm).

“K” dimension specifies location of damper within the sleeve. Minimum is 4 in. (102mm), maximum is “L” less 4 in. (102mm), which allows for retaining angle installation, and duct connection at each end of the sleeve. If “K” dimension is not specified, it will be provided as one half of “L” dimension (damper centered in sleeve).

Note: If using access doors, the door should be installed on the “K” side of the damper.

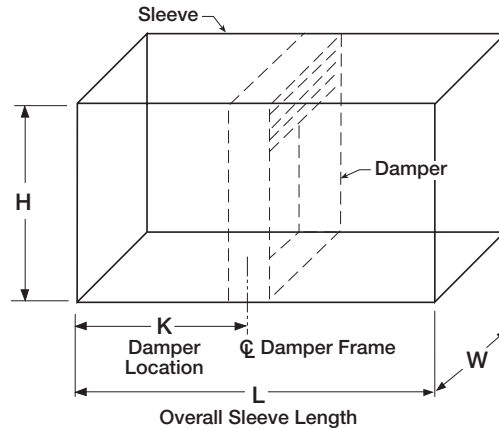

Sealed Option

When sealed option is selected, damper sleeve will be sealed to the damper frame or selected transition using UL approved sealant. For B transitions, the corners will need to be field sealed in the area where the duct to sleeve connection is made.

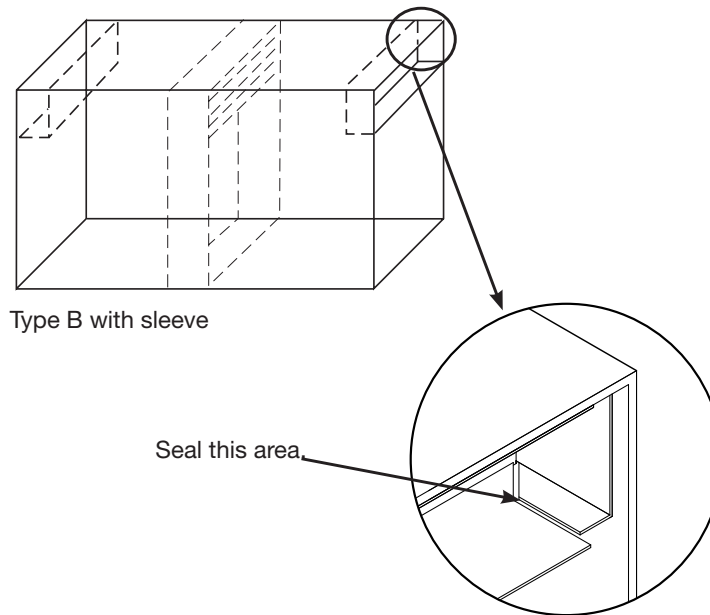

Type A, B, & B2

Dampers larger than maximum single section size are supplied in two or more sections of equal size. Multi-section dampers are factory assembled ready for installation. Dimensions are in inches (mm).

Size Limitations

Inches (mm)	Type A		Type B & B2	
	Minimum	Maximum	Minimum	Maximum
Single Section Vertical	4 x 4 (102 x 102)	48 x 48 (1219 x 1219)	4 x 3 (102 x 76)	48 x 42 (1219 x 1067)
Multi Section Vertical*	NA	96 x 48, 74 x 74 or 120 x 40 (2438 x 1219, 1880 x 1880 or 3048 x 1016)	NA	96 x 42, 74 x 69 or 120 x 35 (2438 x 1067, 1880 x 1753 or 2048 x 889)
Single Section Horizontal	4 x 4 (102 x 102)	48 x 48 (1219 x 1219)	4 x 3 (102 x 76)	48 x 36 (1219 x 914)
Multi Section Horizontal*	NA	96 x 48 or 120 x 40 (2438 x 1219 or 3048 x 1016)	NA	96 x 42 or 120 x 35 (2438 x 1067 or 3048 x 889)

*Consult factory for number of sections.

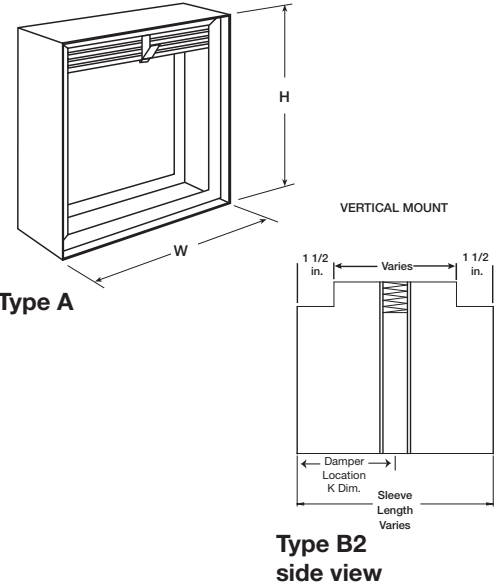

Maximum Single Section Dimensions

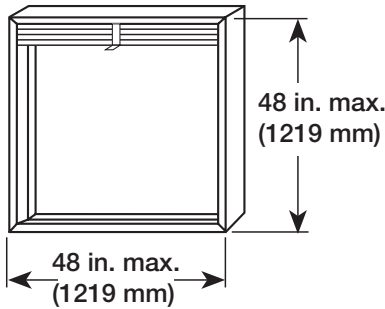

Type A Single Section

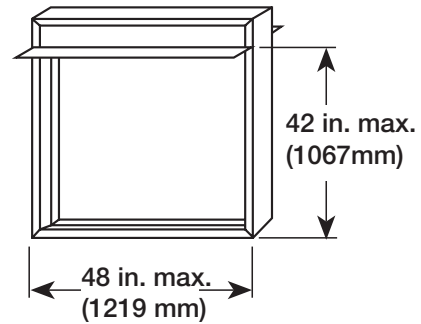

Type B Single Section

Maximum Multi-Section Dimensions

Maximum height is 74 in. (1880mm) when width is less than or equal to 74 in. (1880mm). Vertical mullion provided on dampers over 37 in. (940 mm) wide and 48 in. (1219 mm) high.

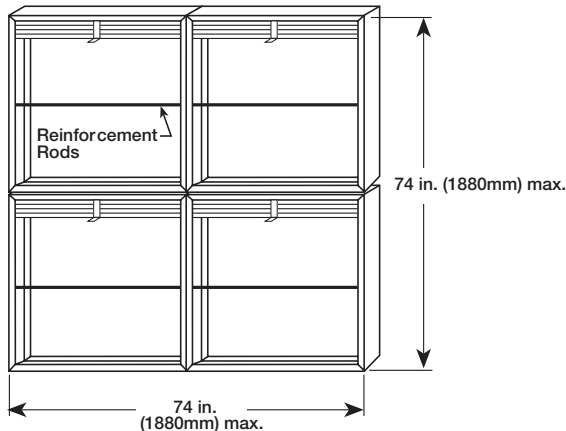

Type A

Maximum height is 69 in. (1753 mm) when width is less than or equal to 74 in. (1880 mm). Vertical mullion provided on dampers over 37 in. (940 mm) and 43 in. (1092 mm) high.

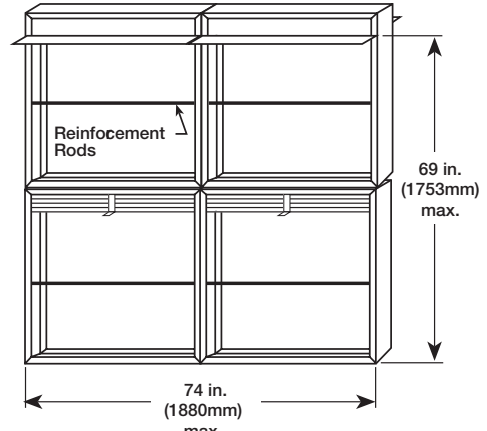

Type B

Note: All multi-section dampers with transitions will include a factory sleeve. When transition type is B or B2 on multi-section high dampers, the top section(s) are Type B or B2 and the bottom section(s) are Type A.

Type B & B2 Overall Dimensions

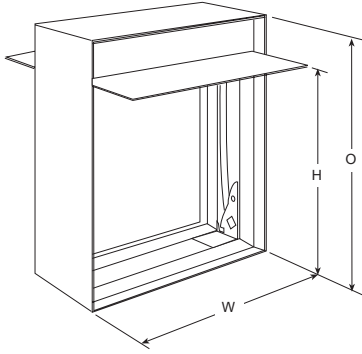

Type B

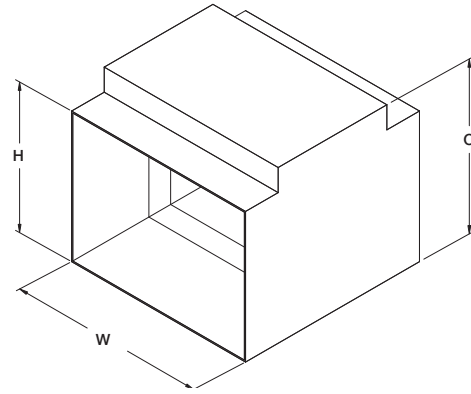

Type B2

H*	O*
3 (76)	5 (127)
4 (102)	6 (152)
5 (127)	7 (178)
6 (152)	8 (203)
7 (178)	9 (229)
8 (203)	10 (254)
9 (229)	11 (279)
10 (254)	12 (305)
11 (279)	13 (330)
12 (305)	14 (356)
13 (330)	15 (381)
14 (356)	16 (406)
15 (381)	18 (457)
16 (406)	19 (483)
17 (432)	20 (508)
18 (457)	21 (533)
19 (483)	22 (559)
20 (508)	23 (584)
21 (533)	24 (610)
22 (559)	26 (660)
23 (584)	27 (686)
24 (610)	28 (711)
25 (635)	29 (737)
26 (660)	30 (762)
27 (686)	31 (787)
28 (711)	32 (813)
29 (737)	33 (838)
30 (762)	34 (864)
31 (787)	36 (914)
32 (813)	37 (940)
33 (838)	38 (965)
34 (864)	39 (991)
35 (889)	40 (1016)
36 (914)	41 (1041)

H*	O*
37 (940)	42 (1067)
38 (965)	44 (1118)
39 (991)	45 (1143)
40 (1016)	46 (1168)
41 (1041)	47 (1194)
42 (1067)	48 (1219)
43 (1092)	49 (1245)
44 (1118)	49 (1245)
45 (1143)	49 (1245)
46 (1168)	50 (1270)
47 (1194)	51 (1295)
48 (1219)	52 (1321)
49 (1245)	53 (1346)
50 (1270)	54 (1372)
51 (1295)	55 (1397)
52 (1321)	56 (1422)
53 (1346)	57 (1448)
54 (1372)	58 (1473)
55 (1397)	59 (1499)
56 (1422)	60 (1524)
57 (1448)	61 (1549)
58 (1473)	62 (1575)
59 (1499)	63 (1600)
60 (1524)	64 (1626)
61 (1549)	65 (1651)
62 (1575)	66 (1676)
63 (1600)	67 (1702)
64 (1626)	68 (1727)
65 (1651)	70 (1778)
66 (1676)	71 (1803)
67 (1702)	72 (1829)
68 (1727)	73 (1854)
69 (1753)	74 (1880)

* Dimensions are in inches (mm). These dimensions are furnished 1/4 in. (6mm) undersize. All 'H' dimensions larger than 43 in. (1092mm) are two sections high.

Type C, CO, & CR

Dampers larger than maximum single section size are supplied in two or more sections of equal size. Multi-section dampers are factory assembled ready for installation. Dimensions are in inches (mm).

Inches (mm)	Type CR		Type CO & C	
	Minimum	Maximum	Minimum	Maximum
Single section Vertical	3 (76)	41 (1041)	3 x 3 (76 x 76)	46 x 41 (1168 x 1041)
Multi Section Vertical**	NA	68 (1727)	NA	94 x 41, 72 x 68 or 118 x 34 (2388 x 1041, 1829 x 1727 or 2997 x 864)
Single Section Horizontal	3 (76)	41 (1041)	3 x 3 (76 x 76)	46 x 41 (1168 x 1041)
Multi Section Horizontal**	NA	NA	NA	94 x 41 or 118 x 34 (2388 x 1041 or 2997 x 864)

** Consult factory for number of sections.

Type C

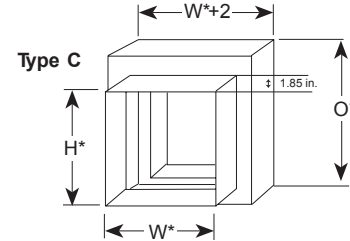
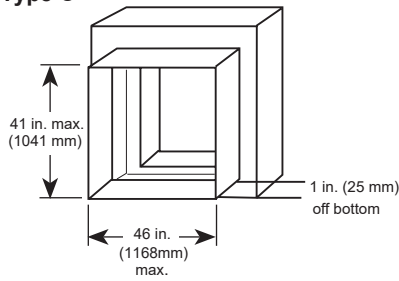

Type CO

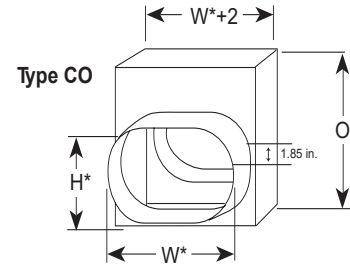
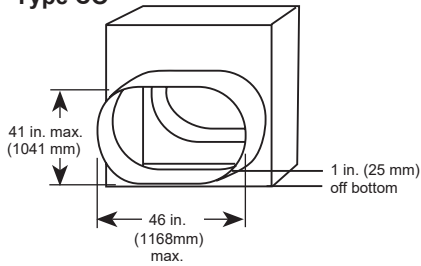

Type CR

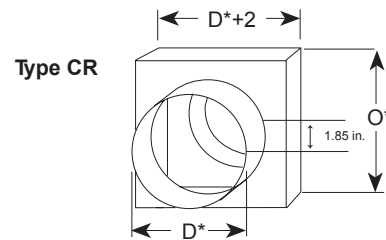
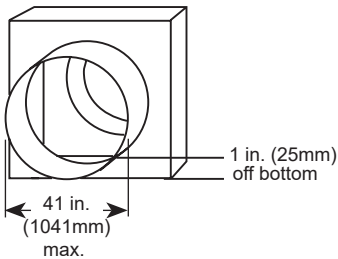

*See page 7 for O dimension information.

C, CO, CR transitions are positioned 1 in. (25mm) from bottom of sleeve.

Note: All multi-section dampers with transitions will include a factory sleeve.

H* or D*	O*	H* or D*	O*	H* or D*	O*
3 (76)	6 (152)	25 (635)	30 (762)	47 (1194)	52 (1321)
4 (102)	7 (178)	26 (660)	31 (787)	48 (1219)	53 (1346)
5 (127)	8 (203)	27 (686)	32 (813)	49 (1245)	54 (1372)
6 (152)	9 (229)	28 (711)	33 (838)	50 (1270)	55 (1397)
7 (178)	10 (254)	29 (737)	34 (864)	51 (1295)	56 (1422)
8 (203)	11 (279)	30 (762)	36 (914)	52 (1321)	57 (1448)
9 (229)	12 (305)	31 (787)	37 (940)	53 (1346)	58 (1473)
10 (254)	13 (330)	32 (813)	38 (965)	54 (1372)	59 (1499)
11 (279)	14 (356)	33 (838)	39 (991)	55 (1397)	60 (1524)
12 (305)	15 (381)	34 (864)	40 (1016)	56 (1422)	61 (1549)
13 (330)	16 (406)	35 (889)	41 (1041)	57 (1448)	62 (1575)
14 (356)	18 (457)	36 (914)	42 (1067)	58 (1473)	63 (1600)
15 (381)	19 (483)	37 (940)	44 (1118)	59 (1499)	64 (1626)
16 (406)	20 (508)	38 (965)	45 (1143)	60 (1524)	65 (1651)
17 (432)	21 (533)	39 (991)	46 (1168)	61 (1549)	66 (1676)
18 (457)	22 (559)	40 (1016)	47 (1194)	62 (1575)	67 (1702)
19 (483)	23 (584)	41 (1041)	48 (1219)	63 (1600)	68 (1727)
20 (508)	24 (610)	42 (1067)	49 (1245)	64 (1626)	70 (1778)
21 (533)	26 (660)	43 (1092)	49 (1245)	65 (1651)	71 (1803)
22 (559)	27 (686)	44 (1118)	49 (1245)	66 (1676)	72 (1829)
23 (584)	28 (711)	45 (1143)	50 (1270)	67 (1702)	73 (1854)
24 (610)	29 (737)	46 (1168)	51 (1295)	68 (1727)	74 (1880)

* Dimensions are in inches (mm). These dimensions are furnished ¼ in. (6mm) undersize except round and oval dimensions are approximately ⅛ in. (3mm) undersize. All 'H' dimensions larger than single section height are two sections high.

Type R

Inches (mm)	Type R*		
	Minimum	Maximum with 1 in. offset	Maximum with 2 in. offset
Single Section Vertical	3 (76)	47 (1194)	46 (1168)
Multi Section Vertical**	NA	73 (1854)	72 (1829)
Single Section Horizontal	3 (76)	47 (1194)	46 (1168)
Multi Section Horizontal	NA	NA	NA

* Sizes are based on 165°F closure temperature and 2000 fpm. Consult factory for maximum size for different temperatures and velocities.

** Consult factory for number of sections.

Overall Damper Dimensions

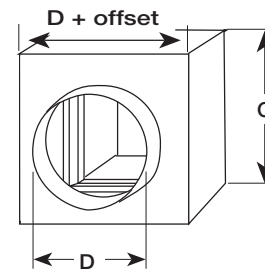

Type R transition is centered in damper sleeve.

To calculate O Dimension:

Diameter + offset (1 or 2 in.) = O Dimension