

Application

Model HB-230 is a heavy duty backdraft damper with a double flanged galvanized steel channel frame and double thickness fabricated airfoil blades. It is designed to prevent backflow and to provide shutoff in HVAC or industrial process systems. External heavy duty linkage, blade counterbalance, and ball bearings are standard.

Ratings

Velocity

Up to 5150 fpm (26.2 m/s)

Temperature

-20° to 250°F (-29° to 121°C)

Consult factory for temperatures above 250°F (121°C)

Pressure

Up to 13.5 in. wg (3.4 kPa) - differential pressure

Construction

	Standard	Optional
Frame Depth	8 in. (203 mm)	8 in - 12 in. (203 mm - 305 mm)
Frame Material	Galvanized steel	Carbon steel, 304SS, 316SS
Frame Type	Flanged channel	-
Frame Thickness	14 ga. (2 mm)	10 ga. (3.5mm) 12 ga. (2.7mm)
Flange Width (D)	2 in. (51 mm)	1½ in. (38 mm)
Blade Material	Galvanized steel	Galvanneal, 304SS, 316SS
Blade Seals	Silicone	EPDM, None
Blade Thickness	18 ga. (1.5mm)	16 ga. (1.5mm)
Blade Type	Fabricated Airfoil	
Linkage	External heavy duty type with steel clevis arms and plated steel tie bars & pivot pins with nylon pivot bearings	304SS, 316SS
Axle Diameter	¾ in. (19 mm) square	-
Axle Bearing	Galvanized ball	External ball
Axle Material	Plated steel	303SS, 316SS
Airflow	-	Horizontal, Vertical Up, Vertical Down, Angular Up, Angular Down
Paint Finishes	Mill finish	Hi Pro Polyester, Industrial Epoxy
Mounting Holes	None	Standard, Standard with corner holes



RH

* Actual inside dimension.

** RH counterbalance is standard.

*** Counterbalance weights extend beyond inlet flange in the open position.

Counterbalance Weight Dimensions

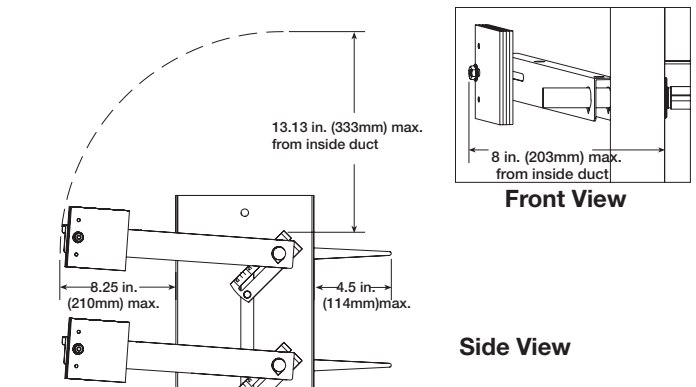

Advise air flow direction & counterbalance weight location when ordering

Size Limitations

W x H	Minimum Size	Maximum Size	
		Single Section	Multi - Section
Inches	6 x 6	60 x 96	120 x 96
mm	152 x 152	1524 x 2438	3048 x 2438

Performance Data

Pressure Drop Data

This pressure drop data was conducted in accordance with AMCA Standard 500-D using the three configurations shown. All data has been corrected to represent standard air at a density of .075 lb/ft³ (1.2 kg/m³).

Actual pressure drop found in any HVAC system is a combination of many factors. This pressure drop information along with an analysis of other system influences should be used to estimate actual pressure losses for a damper installed in a given HVAC system.

AMCA Test Figures

Figure 5.3 illustrates a fully ducted damper. This configuration has the lowest pressure drop of the three test configurations because the entrance and exit losses are minimized by straight duct runs upstream and downstream of the damper.

Figure 5.2 illustrates a ducted damper exhausting air into an open area. This configuration has a lower pressure drop than Figure 5.5 because the entrance losses are minimized by a straight duct run upstream of the damper.

Figure 5.5 illustrates a plenum mounted damper. This configuration has the highest pressure drop because of the high entrance and exit losses due to the sudden changes of area in the system.

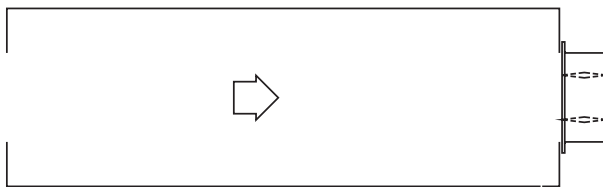
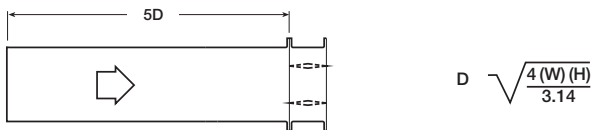
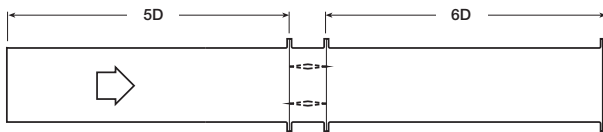

Pressure Drop

12 in. x 12 in. (305mm x 305mm) Damper

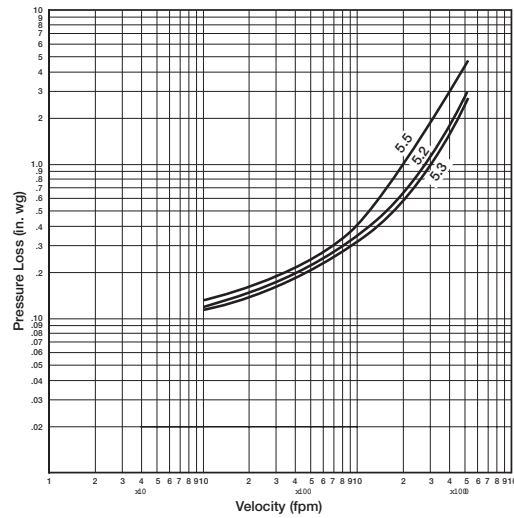

Pressure Drop

24 in. x 24 in. (610mm x 610mm) Damper

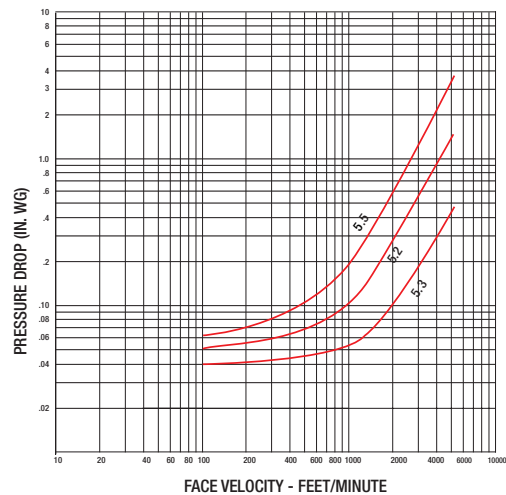

Pressure Drop

36 in. x 36 in. (914mm x 914mm) Damper

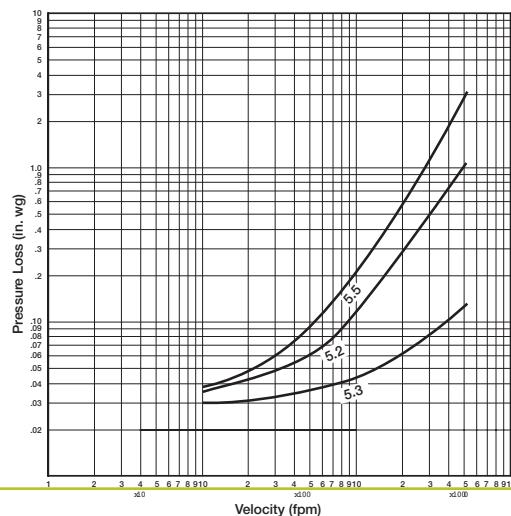

Leakage Data

Leakage testing was conducted in accordance with AMCA Standard 500-D and is expressed as CFM per sq. ft. of damper face area. All data has been corrected to represent standard air at a density of 0.075 lb/ft³ (1.2 kg/m³).

Leakage

36 in. x 36 in. (914mm x 914mm) Damper

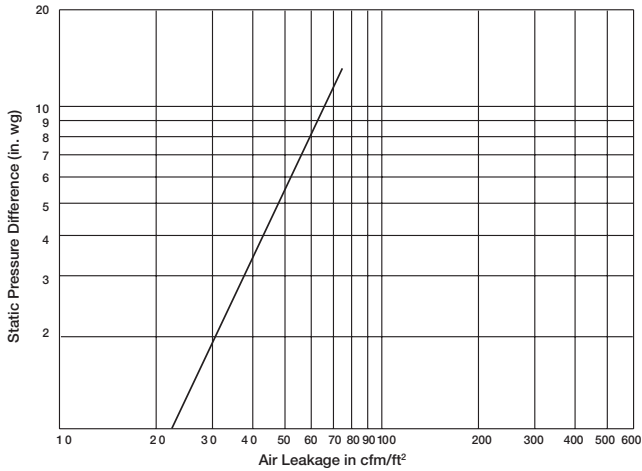

Pressure Limitations

The chart below shows conservative pressure limitations based on a maximum blade deflection of $w/360$.

Temperature Limitations

Blade seals: -40° to 250°F (-40° to 121°C)

For higher temperatures, consult factory.

Velocity Limitations

The chart at below shows velocity limitations based on damper size.

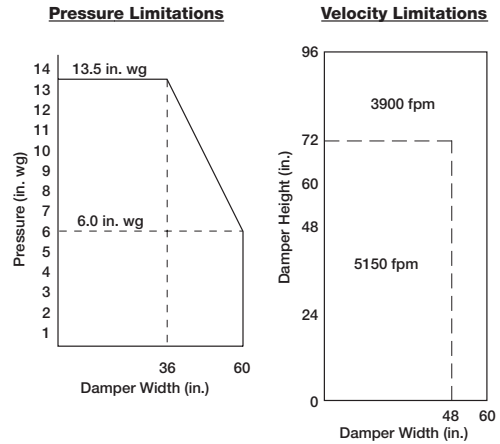

Mounting Holes

Bolt holes are available as an option. The standard pattern is $\frac{7}{16}$ in. (11mm) diameter holes (M dimension) spaced 6 in. (152mm) on center (L dimension). Custom bolt hole patterns are available. Contact factory for the limitations.

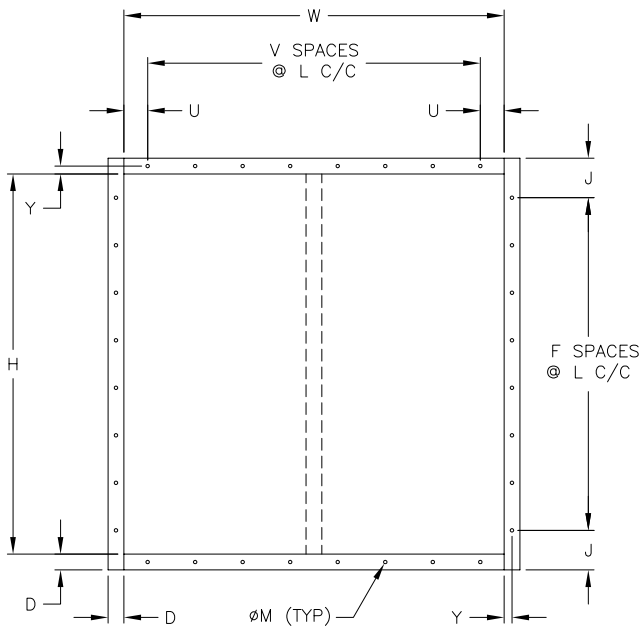

Standard Mounting Hole Pattern
Typical for single or double wide panel

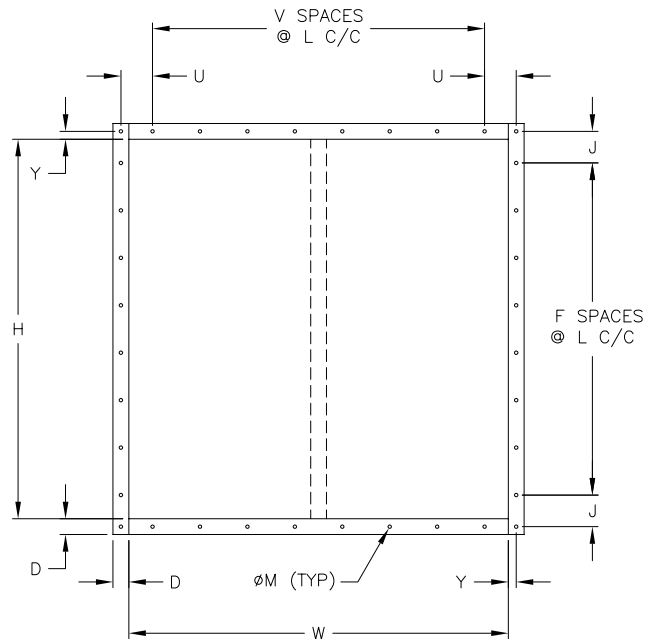

Standard Mounting Hole Pattern with Corner Holes
Typical for single or double wide panel

Multiple Sections

Damper sizes larger than 60 in. x 96 in. (1524mm x 2438mm) and less than 120 in. x 96 in. (3048mm x 2438mm) will be supplied in one frame with two sets of blades separated by a mullion as shown below. Counterbalance weights supplied on right hand and left hand side. For sizes larger than 120 in. x 96 in. (3048mm x 2438mm), consult factory.

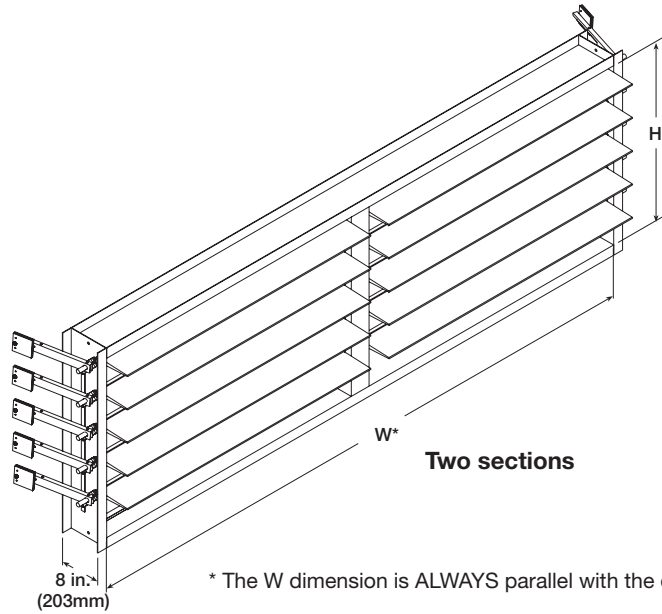

Document Links

[Installation Instructions](#)



[Heavy Duty/Industrial Damper Catalog](#)



[Heavy Duty and Industrial Product Selection Guide](#)



[Damper Interactive Selection Guide](#)



[Specifications](#)



[Warranty](#)

