

Application

The HBT-321 is heavy duty rectangular damper designed for isolation and decontamination applications. The damper has bubble tight leakage performance per AMCA 500-D up to 20 in. wg (5 kPa). The damper frame is flanged for easy mounting and the blade seal is mechanically fastened to the blade.

Ratings

Velocity

4000 fpm (20.3 m/s)

Pressure

20 in. wg (5 kPa) - differential pressure

Leakage

Bubble tight per AMCA 500-D

Temperature

-40 to 250°F (-40 to 121°C)

Construction

	Standard	Optional
Frame Depth (C)	See chart	-
Frame Material	Painted	304SS, 316SS
Frame Type	Flanged Channel	
Frame Thickness	12 ga. (2.7 mm)	-
Flange Width (D)	2 in. (51mm)	3 in. (76 mm)
Blade Action	Parallel	-
Blade Material	Painted	304SS, 316SS
Blade Seals	Silicone	-
Blade Thickness*	12 ga. (2.7 mm)	-
Blade Type	Rectangular butterfly	
Linkage	Plated steel	304SS, 316SS
Axle Diameter**	¾ in. (19 mm) or 1 in. (25 mm)	-
Axle Bearing	Outboard ball	-
Axle Material	Plated steel	303SS, 316SS
Axle Seals	Double gland stuffing box	-
Paint Finishes	Hi Pro Polyester	Industrial Epoxy, Mill finish (304SS or 316SS)
Mounting Holes	None	Standard, Standard with corner holes

* with 12 ga. backing plate

** Axle diameter is based on damper size, required torque, and actuator selection. Consult factory for specific information.

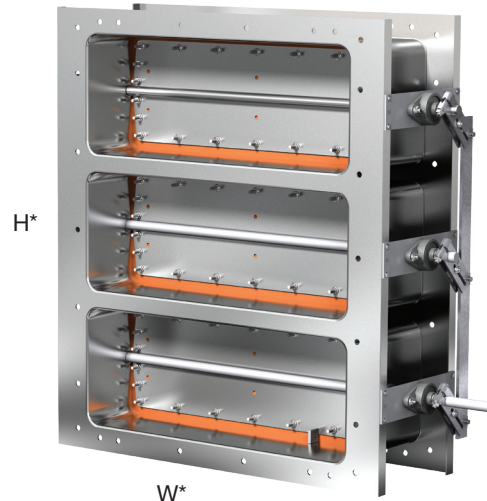

* Actual inside dimension. The W dimension is ALWAYS parallel with the damper blade length.

Axles must always be in the horizontal plane.

Frame Depth

Damper Height Inches (mm)		Number of Blades			
		1	2	3	4
Above	Through	Frame Depth - Inches (mm)			
5.99 (152)	8 (203)	8 (203)	-	-	-
8 (203)	10 (254)	10 (254)	-	-	-
10 (254)	12 (305)	12 (305)	-	-	-
12 (305)	14 (356)	14 (356)	-	-	-
14 (356)	17½ (445)	-	8 (203)	-	-
17½ (445)	21½ (546)	-	10 (254)	-	-
21½ (546)	25½ (648)	-	12 (305)	-	-
25½ (648)	27 (686)	-	-	8 (203)	-
27 (686)	33 (838)	-	-	10 (254)	-
33 (838)	39 (991)	-	-	12 (305)	-
39 (991)	42 (1067)	-	-	-	10 (254)

Size Limitations

W x H	Minimum Size	Maximum Size	
		1 Blade	2 Blades
Inches	6 x 6	48 x 14	48 x 25½
mm	152 x 152	1219 x 356	1219 x 648
		3 Blades	4 Blades
Inches		48 x 39	48 x 42
mm		1219 x 991	1219 x 1067

Performance Data

Pressure Drop Data

This pressure drop data was conducted in accordance with AMCA Standard 500-D using the three configurations shown. All data has been corrected to represent standard air at a density of .075 lb/ft³ (1.2 kg/m³).

Actual pressure drop found in any HVAC system is a combination of many factors. This pressure drop information along with an analysis of other system influences should be used to estimate actual pressure losses for a damper installed in a given HVAC system.

AMCA Test Figures

Figure 5.3 illustrates a fully ducted damper. This configuration has the lowest pressure drop of the three test configurations because the entrance and exit losses are minimized by straight duct runs upstream and downstream of the damper.

Figure 5.2 illustrates a ducted damper exhausting air into an open area. This configuration has a lower pressure drop than Figure 5.5 because the entrance losses are minimized by a straight duct run upstream of the damper.

Figure 5.5 illustrates a plenum mounted damper. This configuration has the highest pressure drop because of the high entrance and exit losses due to the sudden changes of area in the system.

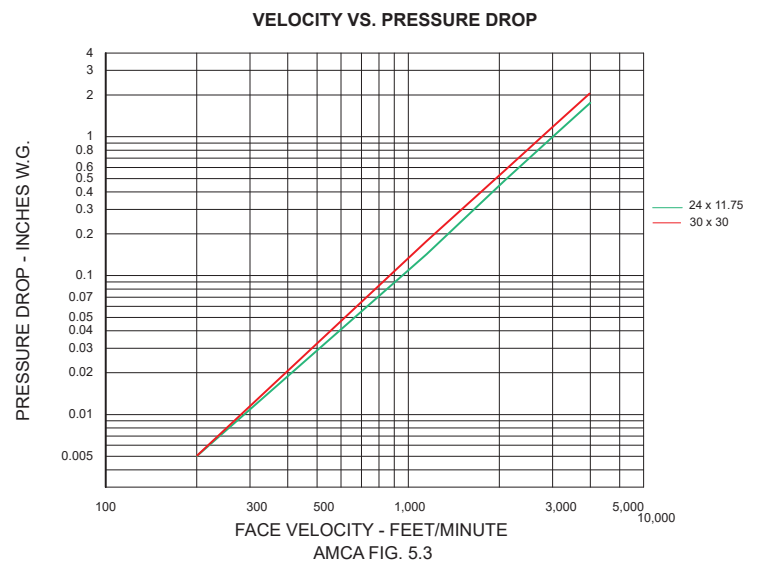
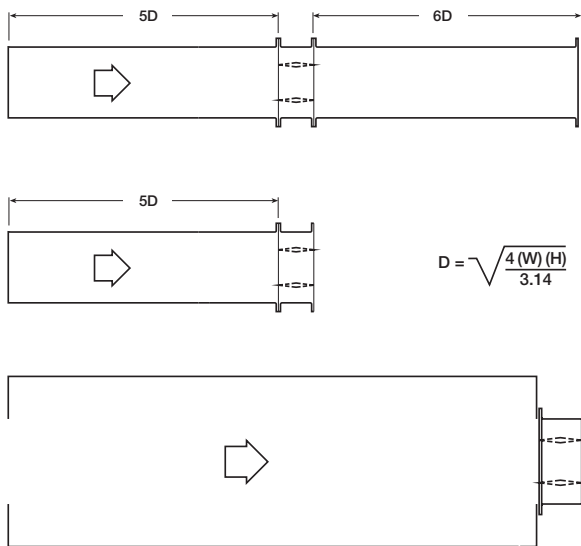

Leakage

Every HBT-321 is leakage tested at 20 in. wg (5 kPa) in accordance with AMCA 500-D before it leaves the factory. The HBT-321 does not ship unless it meets the requirements of the standard.

Bearings and Axle Seal



Relubricable Ball Bearing

The relubricable ball bearing features a flanged cast iron housing that is bolted externally to the damper frame. Capable of high radial loads, this bearing can be applied in applications with high pressures or velocities. Seals protect the bearings' balls from the environment, making this bearing a better choice for application in dirty environments. External grease zerks allow for easy relubrication of the bearing.

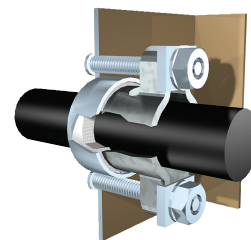

Double Gland Stuffing Box

The double gland stuffing box is recommended for clean air, contaminated air, and high temperatures.

Mounting Holes

Bolt holes are available as an option. The standard pattern is 7/16 in. (11mm) diameter holes (M dimension) spaced 4 in. (102mm) on center (L dimension). Custom bolt hole patterns are available. Contact factory for the limitations.

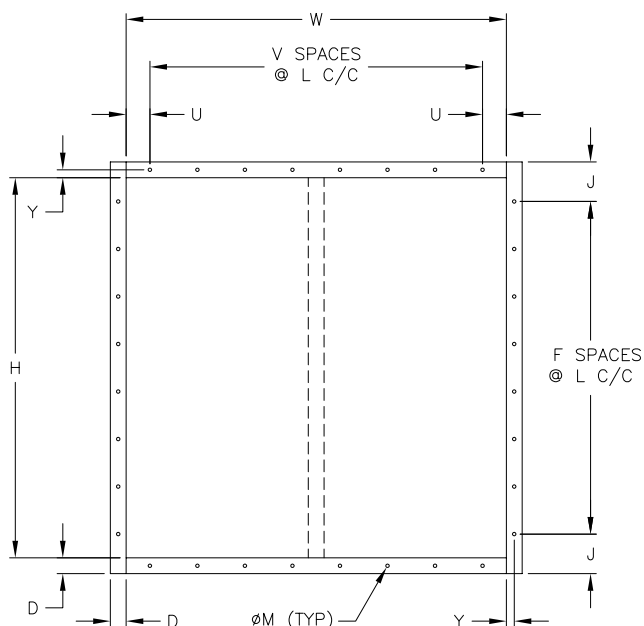

Standard Mounting Hole Pattern
Typical for single or double wide panel

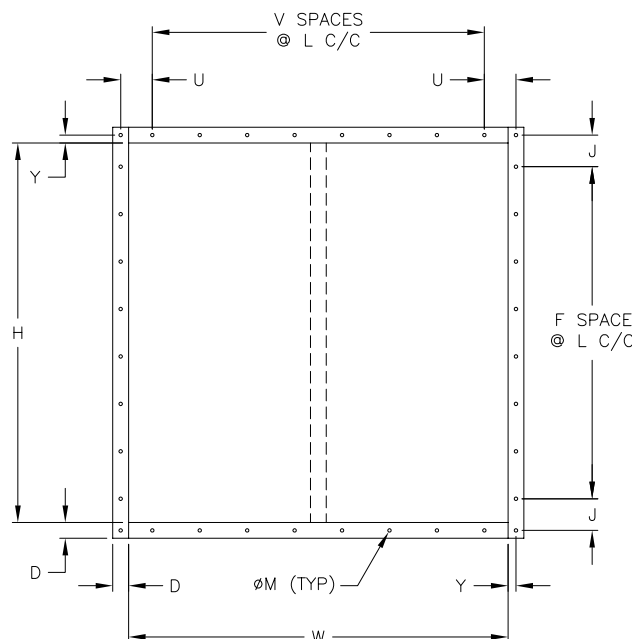

Standard Mounting Hole Pattern with Corner Holes
Typical for single or double wide panel

Document Links



[INSTALLATION](#)



[CATALOG](#)



[ISOLATION DAMPERS](#)



[SUPPLEMENTAL INFORMATION](#)



[SELECTION GUIDE](#)



[DAMPER SELECTION GUIDE](#)



[SPECIFICATIONS](#)



[WARRANTY](#)