

## Application

Model HCD-240 is a heavy duty industrial control damper with a flanged frame. It is designed to control airflow and provide shut off in HVAC or industrial process control systems. A variety of optional features makes model HCD-240 extremely versatile, allowing its capabilities to be tailored to the application. Blade and jamb seals are standard.

## Damper Ratings

### Velocity

Up to 5000 fpm (25.4 m/s)

### Pressure

Up to 15 in. wg (3.7 kPa) - pressure differential

### Temperature

-40°F to 250°F (-40°C to 121°C). Consult factory for temperatures.

## Construction

|                                 | Standard                  | Optional   |
|---------------------------------|---------------------------|--|
| <b>Frame Depth (C)</b>          | 8 in. (203 mm)            | 10 in. (254 mm)  |
| <b>Frame Material</b>           | Galvanized Steel          | 304SS, 316SS, Aluminum   |
| <b>Frame Material Thickness</b> | 14 ga. (2 mm)             | 10 ga. (3.5 mm)<br>12 ga. (2.7 mm)<br>0.125 in. (3.2 mm)                           |
| <b>Frame Type</b>               | Flanged channel           |  |
| <b>Flange Width (D)</b>         | 2 in. (51 mm)             | 1½ in. (64 mm)<br>2½ in. (64 mm)<br>3 in. (76 mm)                                  |
| <b>Blade Material</b>           | Aluminum                  | -  |
| <b>Blade Thickness</b>          | .080 in. (2 mm)           | -  |
| <b>Blade Type</b>               | Extruded Aluminum Airfoil |  |
| <b>Blade Action</b>             | Parallel                  | Opposed  |
| <b>Blade Seals</b>              | Silicone                  | EPDM   |
| <b>Linkage</b>                  | Plated steel              | 304SS, 316SS   |
| <b>Jamb Seals</b>               | 316SS                     | None   |
| <b>Axle Diameter</b>            | ¾ in. (19 mm)             | -  |
| <b>Axle Bearings</b>            | Stainless Steel Sleeve    | External SS Sleeve, External Bronze, External Ball, Outboard Bronze, Outboard Ball |
| <b>Axle Material</b>            | Plated steel              | 303SS, 316SS, Aluminum   |
| <b>Axle Seals</b>               | None                      | O-ring, Double Gland   |
| <b>Paint Finishes</b>           | None                      | Hi Pro Polyester, Hi Temp. Silver Industrial Epoxy                                 |
| <b>Mounting Holes</b>           | None                      | Standard, Standard with corner holes   |

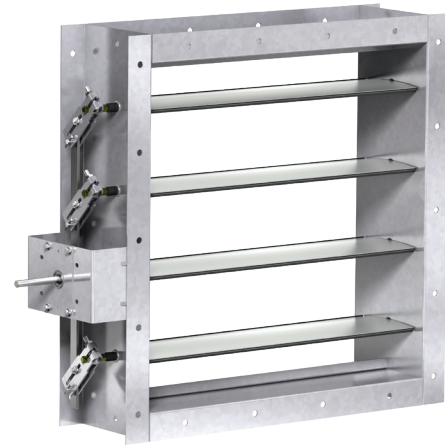

Actuator mounting bracket shown.

\* Actual Inside Dimension. The W dimension is ALWAYS parallel with the damper blade length.

Damper linkage and axles may extend beyond the damper flange based on the configuration of selectable options. Consult factory for dimensions.

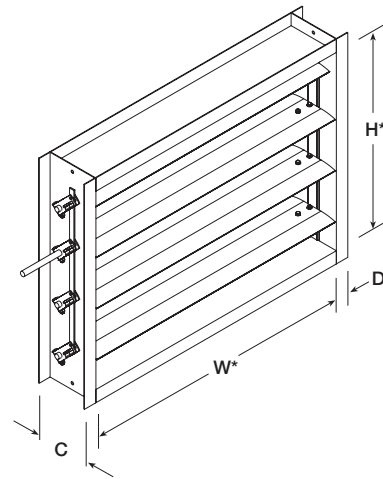

## Size Limitations

| W x H         | Minimum Size | Maximum Size   |                 |
|---------------|--------------|----------------|-----------------|
|               |              | Single Section | Multi - Section |
| <b>Inches</b> | 6½ x 6¼      | 60 x 96        | 120 x 96        |
| <b>mm</b>     | 165 x 158    | 1524 x 2438    | 3048 x 2438     |

## Options

- Wide range of actuators available
- Mounting holes in flanges
- Vertical blade orientation
- Spark resistant (see page 2)

# Spark Resistant

AMCA Standard 99-0401 defines fan material performance requirements for operation in hazardous environments. Dampers meet the spirit of this standard as follows:

- Class A - All materials in the airstream must be non-ferrous
- Class B or C - Damper blades must be non-ferrous

## Construction for Spark 'A' Resistant

- Frame: 8 in. x 2 in. x 1/8 in. (203 mm x 51 mm x 3.2 mm) formed aluminum channel
- Blades: Extruded aluminum airfoil shaped, symmetrical 8 in. (203 mm) maximum width
- Seals: Silicone rubber blade seals. No jamb seal.
- Linkage: External heavy duty type with galvanized steel clevis arms, plated steel tie bars & pivot pins
- Bearings: External mounted relubricable ball bearings
- Finish: Mill finish
- Max Size: Single section 60in x 72in (1524mm x 1829mm)

## Options for Spark 'A' Resistant

- No stainless steel linkage or jamb seal

# Performance Data

## Pressure Limitations

The chart at the right shows conservative pressure limitations based on a maximum blade deflection of w/360.

## Temperature Limitations

**Blade seals:** Silicone -40° to 400°F (-40° to 204°C)  
EPDM -20° to 250°F (-29° to 121°C)

**Jamb seals:** Flexible stainless steel -40° to 400°F (-40° to 204°C)

For higher temperatures, consult factory.

## Velocity Limitations

The chart at far right shows velocity limitations based on damper size.

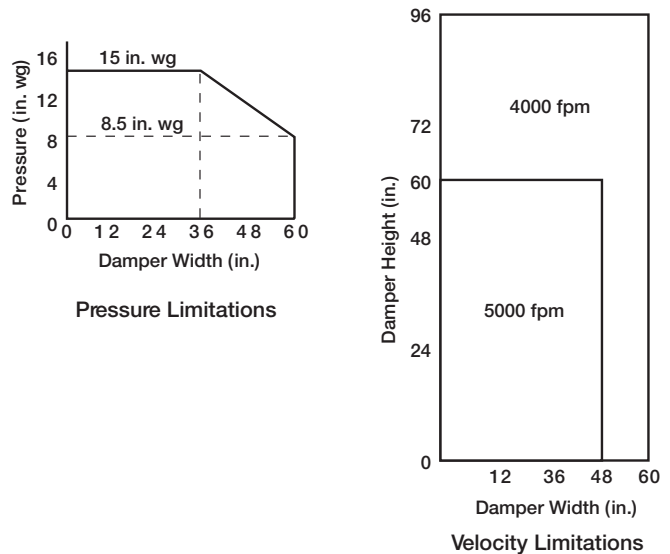

## Pressure Drop Data

This pressure drop data was conducted in accordance with AMCA Standard 500-D using the three configurations shown. All data has been corrected to represent standard air at a density of .075 lb/ft<sup>3</sup> (1.2 kg/m<sup>3</sup>).

Actual pressure drop found in any HVAC system is a combination of many factors. This pressure drop information along with an analysis of other system influences should be used to estimate actual pressure losses for a damper installed in a given HVAC system.

## AMCA Test Figures

**Figure 5.3** illustrates a fully ducted damper. This configuration has the lowest pressure drop of the three test configurations because the entrance and exit losses are minimized by straight duct runs upstream and downstream of the damper.

**Figure 5.2** illustrates a ducted damper exhausting air into an open area. This configuration has a lower pressure drop than Figure 5.5 because the entrance losses are minimized by a straight duct run upstream of the damper.

**Figure 5.5** illustrates a plenum mounted damper. This configuration has the highest pressure drop because of the high entrance and exit losses due to the sudden changes of area in the system.

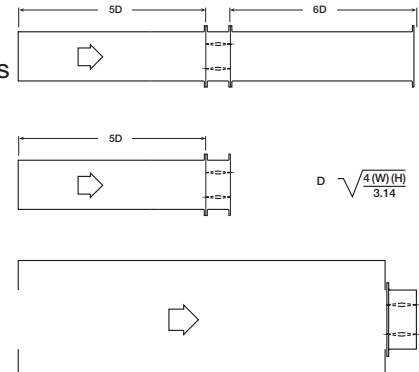

# Pressure Drop Data

## Pressure Drop

36 x 36 in. Damper  
(914 mm x 914 mm)

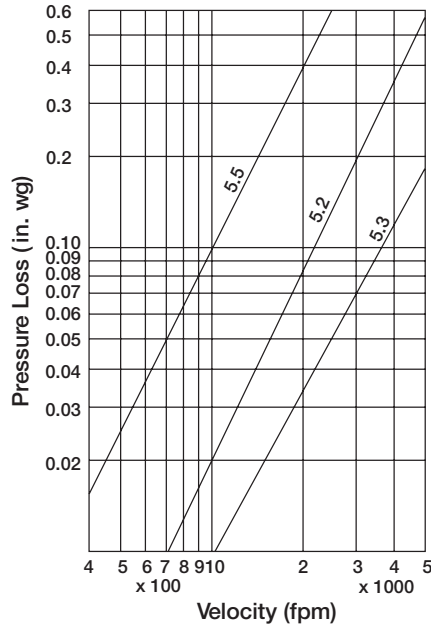

## Leakage Data

Damper leakage (with blades fully closed) varies based on the type of low leakage seals applied. Model HCD-240 is available with no jamb seals (standard) or with stainless steel jamb seals and EPDM, or silicone rubber blade seals. Leakage testing was conducted in accordance with AMCA Standard 500-D and is expressed as CFM per sq. ft. of damper face area. All data has been corrected to represent standard air at a density of .075 lb/ft<sup>3</sup> (1.2 kg/m<sup>3</sup>).

### Leakage

This chart shows worst case scenario based on these sizes:  
 6 in. x 60 in. (152 mm x 1524 mm), 60 in. x 6¼ in. (1524 mm x 159 mm),  
 48 in. x 36 in. (1219 mm x 914 mm), 60 in. x 60 in. (1524 mm x 1524 mm).  
 Based on 5 in. lb/ft<sup>2</sup> of torque.

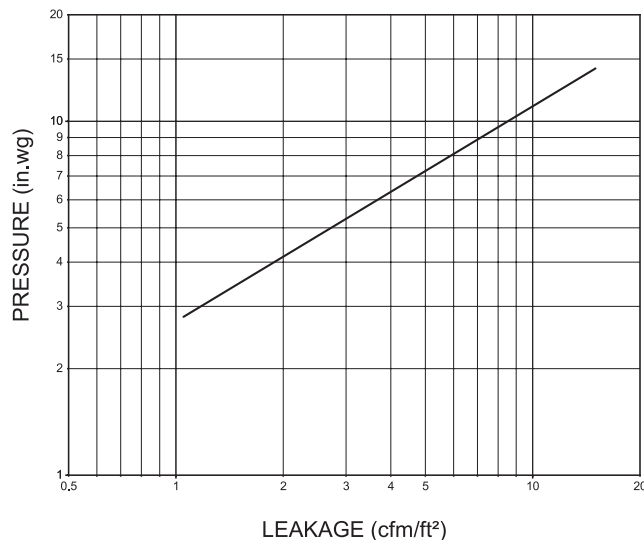

Bolt holes are available as an option. The standard pattern is 7/16 in. (11 mm) diameter holes (M dimension) spaced 6 in. (152 mm) on center (L dimension). Custom bolt hole patterns are available. Contact factory for the limitations.

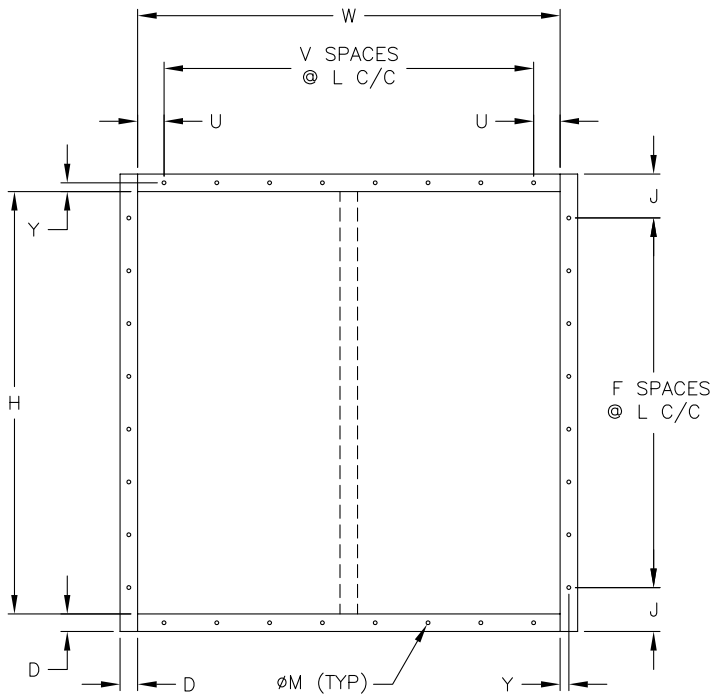

Standard Mounting Hole Pattern  
Typical for single or double wide panel

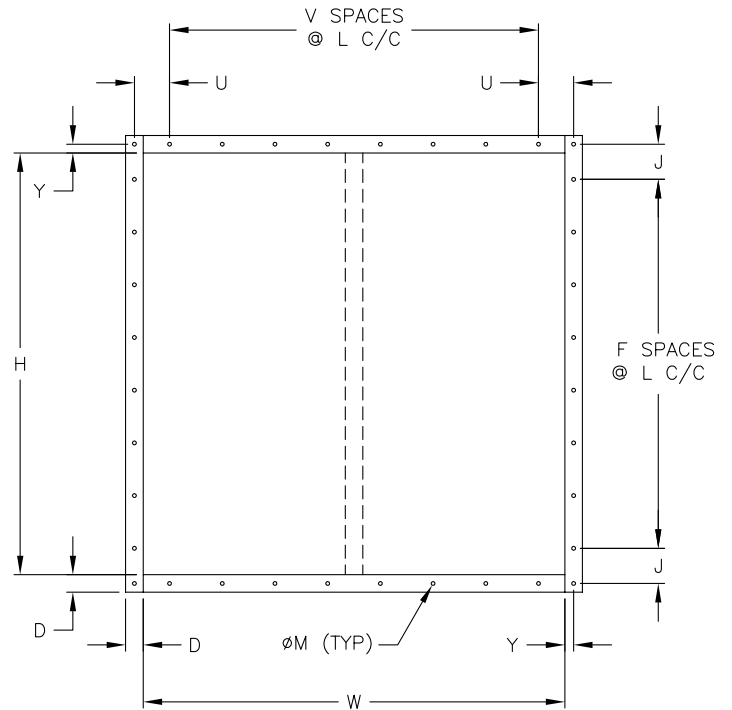

Standard Mounting Hole Pattern with Corner Holes  
Typical for single or double wide panel

## Links



[INSTALLATION](#)



[CATALOG](#)



[HD PRODUCT GUIDE](#)



[SELECTION GUIDE](#)



[WARRANTY](#)



[SPECIFICATIONS](#)