

## Application

Model HCDR-150 is a heavy duty round industrial control damper with a flanged style frame. It is designed to control airflow and provide shut off in HVAC or industrial process control systems.

## Ratings

### Velocity

Up to 4000 fpm (20.3 m/s)

### Temperature

-40° to 400°F (-40° to 204°C)

### Pressure

Up to 6 in. wg (1.5 kPa) - differential pressure

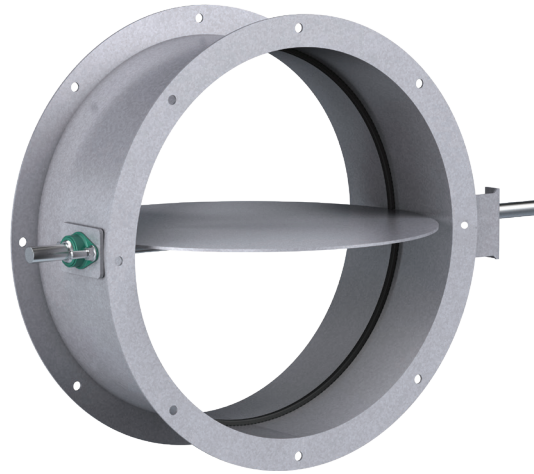

Diameter = Actual Inside Dimension

Diameter	Minimum Size	Maximum Size
Inches	4	48
mm	102	1219

## Construction

	Standard	Optional
<b>Frame Material</b>	Painted	304SS or 316SS
<b>Frame Type</b>	Flanged channel	-
<b>Blade Material</b>	Painted	304SS or 316SS
<b>Blade Seals</b>	None	EPDM or Silicone
<b>Blade Stop</b>	Pin stop	Rolled bar
<b>Blade Type</b>	Round butterfly	
<b>Axle Bearing</b>	Stainless steel sleeve	External bronze
<b>Axle Material</b>	Plated steel	303SS or 316SS
<b>Axle Seals</b>	None	O-ring
<b>Paint Finishes</b>	Hi Pro Polyester	Hi Temperature Flame Control, Hi Temperature Silver, Industrial Epoxy, None
<b>Mounting Holes</b>	None	Parallel, Straddle

## Features

- Wide mounting flanges can be ordered with bolt holes, customized to match your requirements.
- Rolled bar stops are required when blade seal is selected.
- Wide range of actuators available.

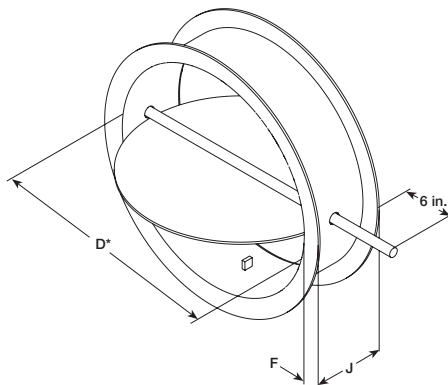

Diameter <i>D</i> Inches (mm)		Frame Depth <i>J</i> Inches (mm)	Frame & Flange Gauge (mm)	Flange Width <i>F</i> Inches (mm)	Axle Diameter Inches (mm)	Blade Thickness Gauge (mm)
Above	Through					
3.99 (101)	12 (305)	6 (152)	12 (2.7)	1.25 (32)	0.5 (13)	10 (3.5)
12 (305)	20 (508)	8 (203)	12 (2.7)	1.5 (32)	0.5 (13)	10 (3.5)
20 (508)	24 (610)	8 (203)	12 (2.7)	1.5 (32)	0.75 (19)	10 (3.5)
24 (610)	36 (914)	8 (203)	10 (3.5)	2.0 (51)	.75 (19)	10 (3.5)
36 (914)	48 (1219)	8 (203)	10 (3.5)	2.0 (51)	1.00 (25)	10 (3.5)

# Options

## Bearing and Shaft Options

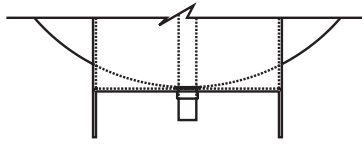

Stainless Steel Sleeve Bearing (Standard)

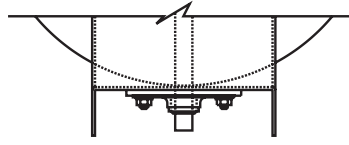

External Mounted Bronze Sleeve Bearing (Optional)

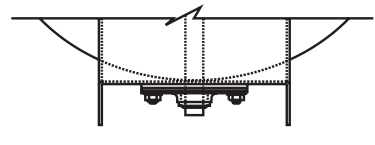

External Mounted Bronze Sleeve Bearing with O-Ring (Optional)

## Blade Seal Options (Rolled Bar Blade Stops Required)

Standard - Does not include Blade Seals

Optional - EPDM Blade Seals (250°F [121°C] max.)

Optional - Silicone Rubber Blade Seals (400°F [204°C] max.)

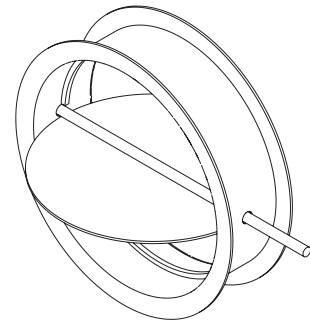

Rolled Bar Blade Stops

## Mounting Holes

The recommended bolt hole pattern is shown in the table below. Customer must specify bolt holes that are parallel to the axle centerline or that straddle the axle centerline as shown in the diagrams below. The factory can also provide bolt hole sizes and patterns other than those shown.

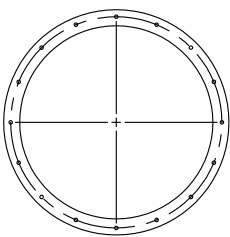
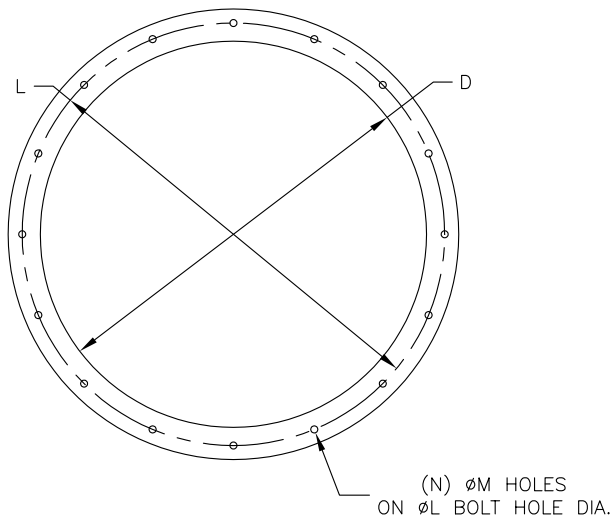

On Centerline

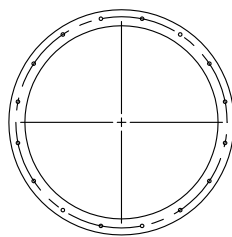

Straddle Centerline

Recommended Bolt Hole Pattern (Bolt Holes Parallel to Axle Centerline)					
Diameter Inches (mm)		Number of Holes	Mounting Hole Diameter in. (mm) N	Bolt Circle Diameter L	Degrees Between Holes
Above	Through				
4 (102)	8 (203)	4	3/8 (9.5)	*	90
8.001 (203)	18 (457)	8	7/16 (11)	*	45
18.001 (457)	24 (610)	12	7/16 (11)	*	30
24.001 (610)	36 (914)	16	7/16 (11)	*	22½
36.001 (914)	58 (1473)	24	7/16 (11)	*	15
58.001 (1473)	72 (1829)	32	9/16 (14)	*	11¼

\* Bolt Circle Diameter = Damper Diameter + Flange Height + ¼ in. (6mm)

# Performance Data

## AMCA Test Figure 5.3

Figure 5.3 illustrates a fully ducted damper. This configuration has low pressure drop because entrance and exit losses are minimized by straight duct runs upstream and downstream of the damper.

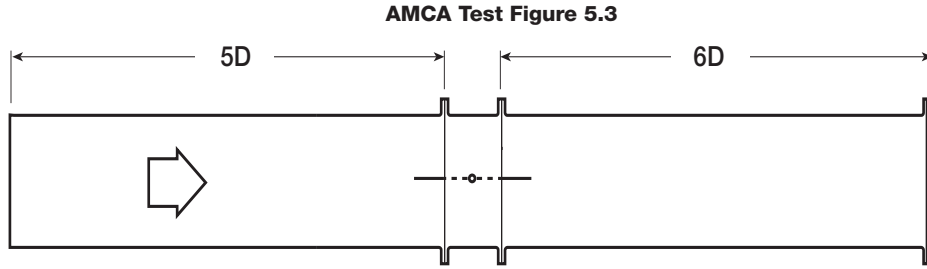

## Pressure Drop Data

This pressure drop data was conducted in accordance with AMCA Standard 500-D using Test Figure 5.3. All data has been corrected to represent standard air at a density of 0.075 lb/ft<sup>3</sup> (1.2 kg/m<sup>3</sup>).

Actual pressure drop found in any HVAC system is a combination of many factors. This pressure drop information along with an analysis of other system influences should be used to estimate actual pressure losses for a damper installed in a given HVAC system.

NOTE: PS refers to damper with standard pin blade stop

BS refers to damper with rolled bar blade stop

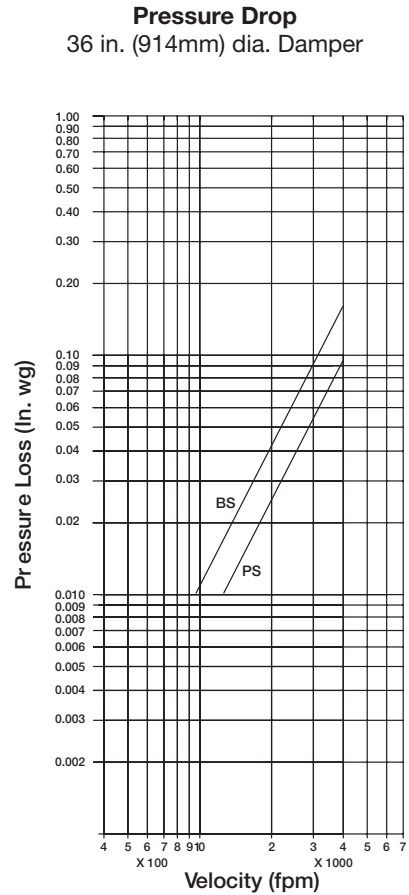
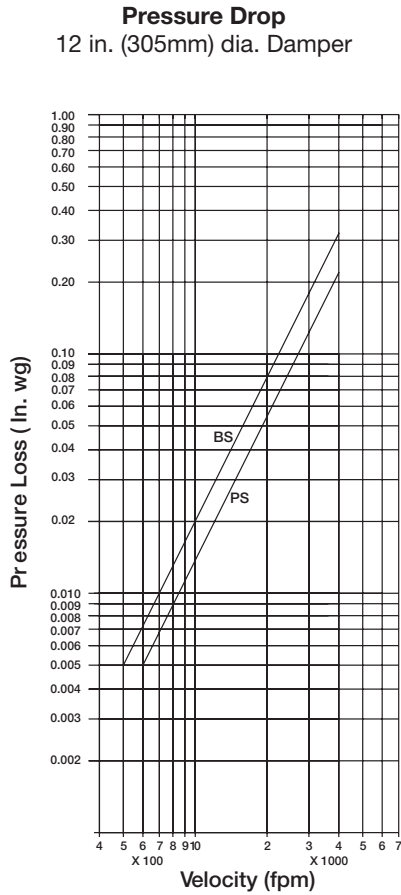

# Leakage

Damper leakage (with blades fully closed) varies based on the type of blade stops and low leakage seals applied. Model HCDR-150 is available with no seals (standard) or with EPDM or silicone rubber blade seals. Leakage testing was conducted in accordance with AMCA Standard 500-D and is expressed as cfm/ft<sup>2</sup> of damper face area. All data has been corrected to represent standard air at a density of 0.075 lb/ft<sup>3</sup> (1.2 kg/m<sup>3</sup>).

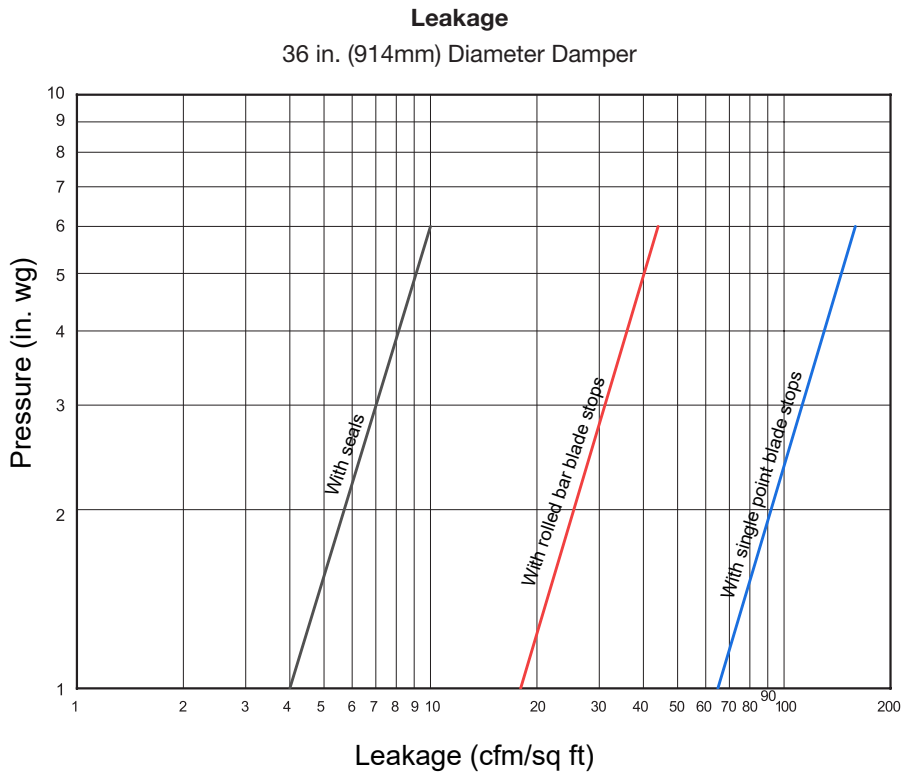
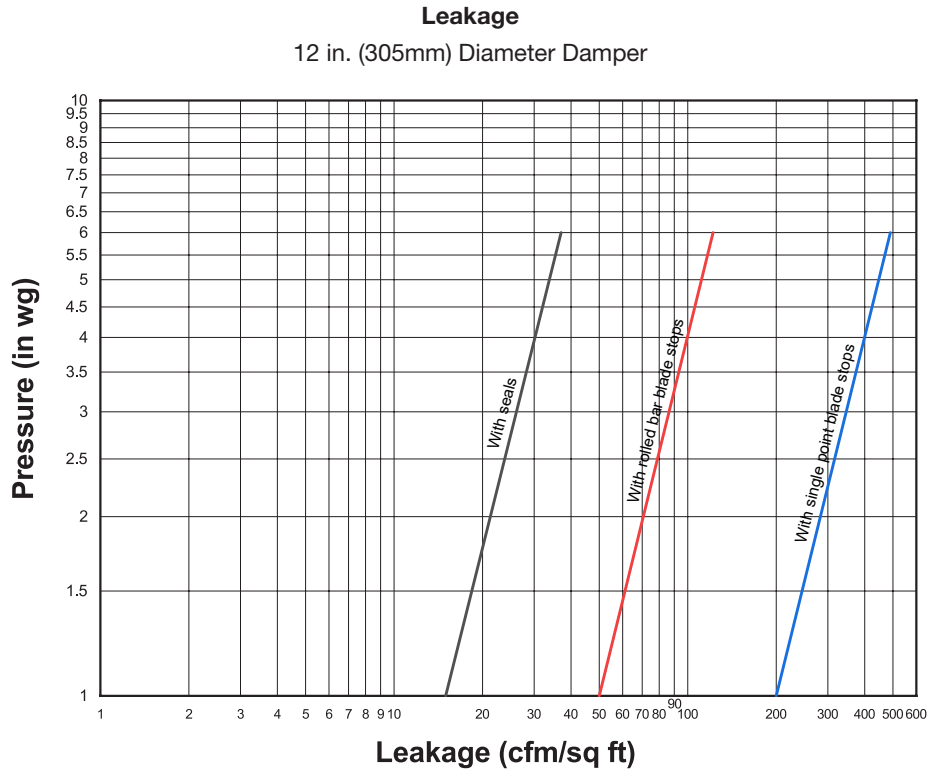

[Installation Instructions](#)



[Heavy Duty/Industrial Damper Catalog](#)



[Heavy Duty and Industrial Product Selection Guide](#)

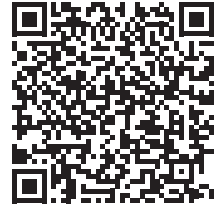

[Damper Interactive Selection Guide](#)



[Specifications](#)

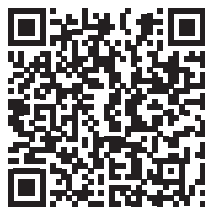

[Warranty](#)

