

### Application and Design

Model HCDR-250 is a heavy duty round industrial control damper with a flanged style frame. It is designed to control airflow and provide shut off in HVAC or industrial process control systems. A variety of optional features (see page 3) makes model HCDR-250 extremely versatile, allowing its capabilities to be tailored to the application.

### Ratings (See pages 2 and 3 for specific limitations)

**Pressure:** Up to 13.5 in. wg (3.4 kPa) - differential pressure

**Velocity:** Up to 5150 fpm (26.5 m/s)

**Temperature:** -40°F to 600°F (-40°C to 315°C). Consult factory for other temperatures.

	Standard	Optional
<b>Frame Material</b>	Painted	304SS or 316SS
<b>Frame Type</b>	Flanged Channel	
<b>Blade Material</b>	Painted	304SS or 316SS
<b>Blade Seals</b>	None	EPDM, Silicone, Fiberglass, or Ceramic
<b>Blade Stops</b>	Pin Stop	Rolled Bar
<b>Blade Type</b>	Round Butterfly	
<b>Axle Bearing</b>	External Bronze through 56 in. (1422mm); External Ball above 56 in. (1422mm) diameter	External Ball, Outboard Bronze, Outboard Ball, Outboard Carbon
<b>Axle Material</b>	Plated Steel	303SS or 316SS
<b>Axle Seals</b>	None	O-ring, Double Gland
<b>Paint Finishes</b>	Hi Pro Polyester	Hi Temperature Flame Control, Hi Temperature Silver, Industrial Epoxy, None

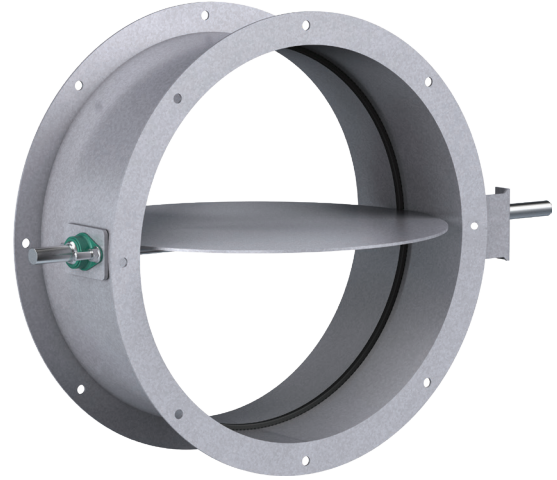

\* Actual Inside Dimension

Diameter	Minimum Size	Maximum Size
Inches	4	72
mm	102	1829

Diameter <i>D</i> Inches (mm)		Frame Depth <i>J</i> Inches (mm)	Frame & Flange Gauge (mm)	Flange Width <i>F</i> Inches (mm)	Axle Diameter Inches (mm)	Blade Thickness Gauge (mm)
Above	Through					
3.99 (101)	12 (305)	6 (152)	12 (2.7)	1.25 (32)	0.5* (13)	10 (3.5)
12 (305)	16 (406)	8 (203)	12 (2.7)	1.5 (32)	0.5* (13)	0.188 (4.8)
16 (406)	24 (610)	8 (203)	12 (2.7)	1.5 (32)	0.75 (19)	0.188 (4.8)
24 (610)	36 (914)	8 (203)	10 (3.5)	2.0 (51)	0.75 (19)	0.188 (4.8)
36 (914)	44 (1118)	8 (203)	10 (3.5)	2.0 (51)	1.00 (25)	0.188 (4.8)
44 (1118)	48 (1219)	8 (203)	0.188 (4.8)	2.0 (51)	1.25 (32)	0.188 (4.8)
48 (1219)	56 (1422)	8 (203)	0.188 (4.8)	2.5 (64)	1.25 (32)	0.188 (4.8)
56 (1422)	60 (1524)	10 (254)	0.188 (4.8)	2.5 (64)	1.50 (38)	0.188 (4.8)
60 (1524)	72 (1829)	10 (254)	0.188 (4.8)	3 (76)	1.50 (38)	0.188 (4.8)

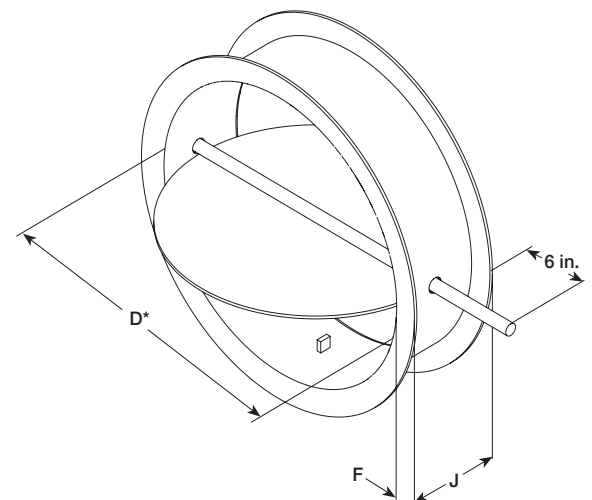

### Features

- Wide mounting flanges can be ordered with bolt holes, customized to match your requirements.
- Rolled bar stops are required when blade seal is selected.
- Wide range of actuators available

\* The axle diameter is .75 in (19mm) when outboard carbon bearings are selected for dampers 16 inches and below.

## Bearing and Shaft Options

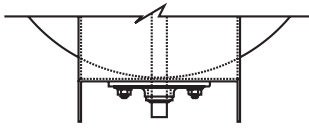

External Mounted  
Ball or Sleeve  
Bearing (Bronze  
Sleeve Standard, Ball  
Optional)

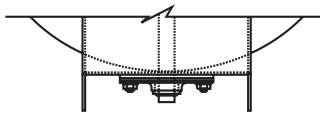

External Mounted  
Bronze Sleeve  
Bearing with O-Ring  
(Optional)

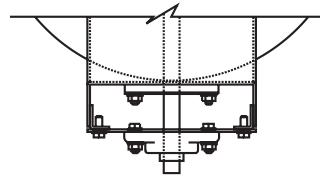

O-Ring Shaft Seal  
with Outboard  
Mounted Bearing  
(Optional)

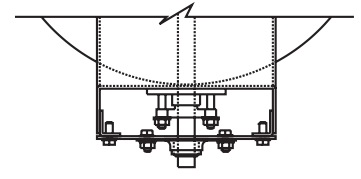

Double Gland  
Stuffing Box with  
Outboard Mounted  
Bearing (Optional)

## Blade Seal Options (Rolled Bar Blade Stops Required)

**Standard** - Does not include Blade Seals

**Optional** - EPDM Blade Seals (250°F [121°C] max.)

**Optional** - Silicone Rubber Blade Seals (400°F [204°C] max.)

**Optional** - Fiberglass or Ceramic Blade Seals (600°F [315°C] max.)

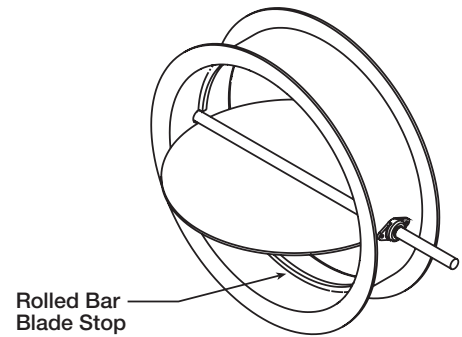

Rolled Bar  
Blade Stop

## Bolt Holes

The recommended bolt hole pattern is shown in the table below. Customer must specify bolt holes that are parallel to the axle centerline or that straddle the axle centerline as shown in the diagrams below. The factory can also provide bolt hole sizes and patterns other than those shown.

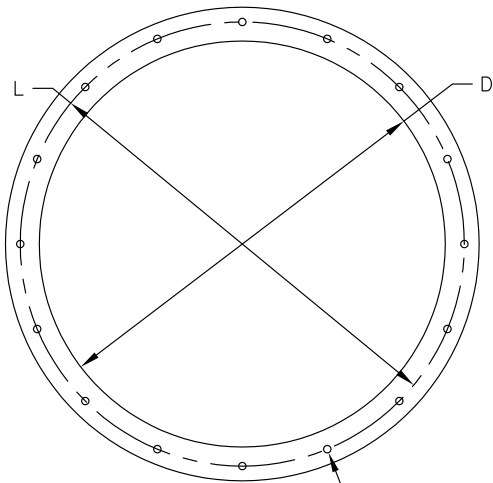

(N)  $\phi$ M HOLES  
ON  $\phi$ L BOLT HOLE DIA.

Recommended Bolt Hole Pattern (Bolt Holes Parallel to Axle Centerline)					
Diameter Inches (mm)		Number of Holes	Mounting Hole Diameter in. (mm) N	Bolt Circle Diameter L	Degrees Between Holes
Above	Through				
4 (102)	8 (203)	4	3/8 (9.5)	*	90
8.001 (203)	18 (457)	8	7/16 (11)	*	45
18.001 (457)	24 (610)	12	7/16 (11)	*	30
24.001 (610)	36 (914)	16	7/16 (11)	*	22 1/2
36.001 (914)	58 (1473)	24	7/16 (11)	*	15
58.001 (1473)	72 (1829)	32	9/16 (14)	*	11 1/4

\* Bolt Circle Diameter = Damper Diameter + Flange Height + 1/4 in. (6mm)

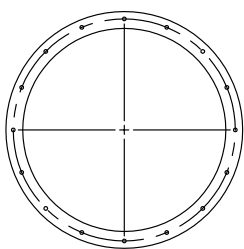

Parallel on Centerline

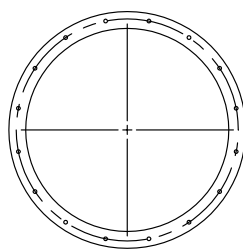

Straddle on Centerline

## AMCA Test Figure 5.3

Figure 5.3 illustrates a fully ducted damper. This configuration has low pressure drop because entrance and exit losses are minimized by straight duct runs upstream and downstream of the damper.

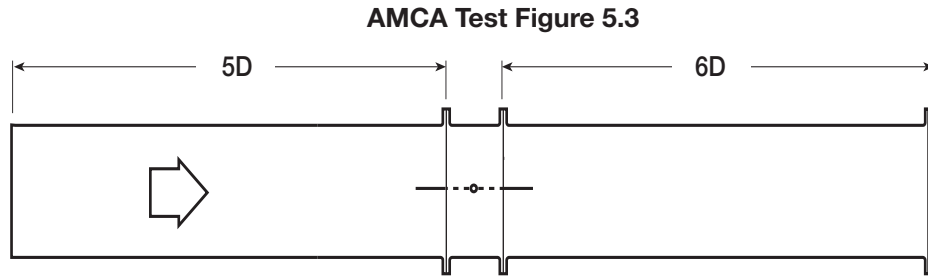

## Pressure Drop Data

This pressure drop data was conducted in accordance with AMCA Standard 500-D using Test Figure 5.3. All data has been corrected to represent standard air at a density of 0.075 lb/ft<sup>3</sup> (1.2 kg/m<sup>3</sup>).

Actual pressure drop found in any HVAC system is a combination of many factors. This pressure drop information along with an analysis of other system influences should be used to estimate actual pressure losses for a damper installed in a given HVAC system.

NOTE:

PS refers to damper with standard pin blade stop

BS refers to damper with rolled bar blade stop

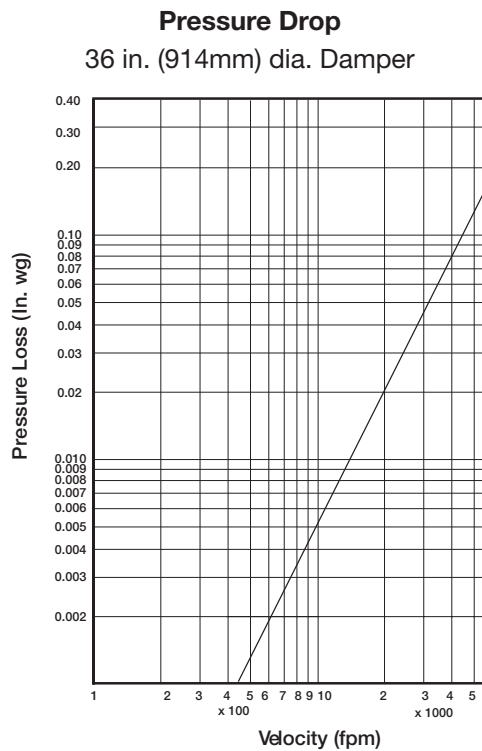
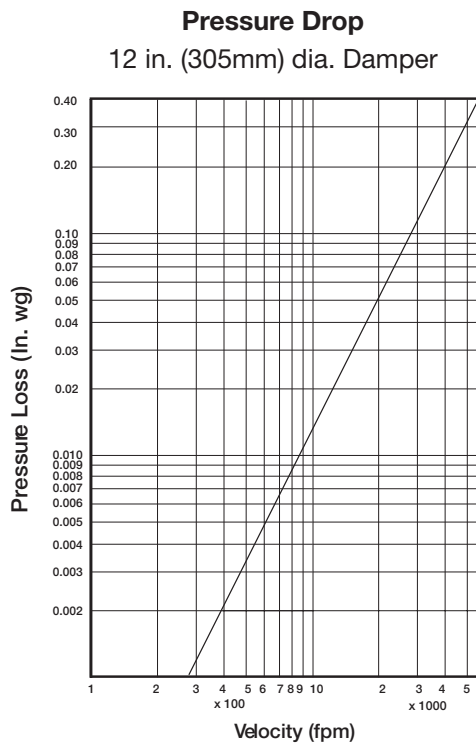

## Leakage Data

Damper leakage (with blades fully closed) varies based on the type of blade stops and low leakage seals applied. Model HCDR-250 is available with no seals (standard) or with EPDM or silicone rubber blade seals. Leakage testing was conducted in accordance with AMCA Standard 500-D and is expressed as  $\text{cfm}/\text{ft}^2$  of damper face area. All data has been corrected to represent standard air at a density of  $0.075 \text{ lb}/\text{ft}^3$  ( $1.2 \text{ kg}/\text{m}^3$ ).

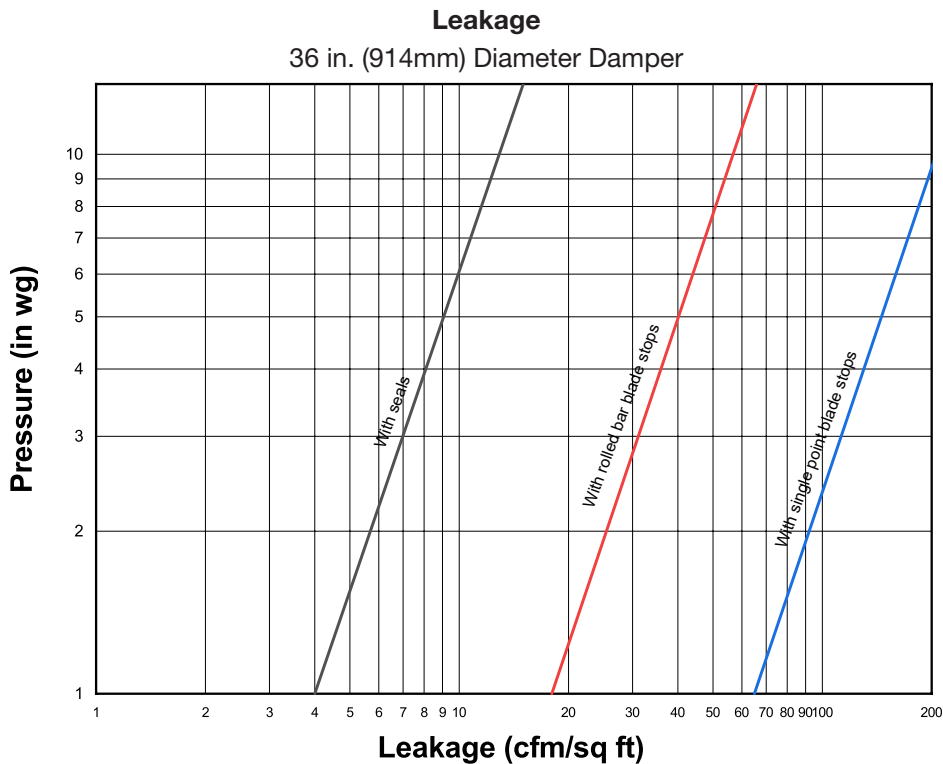
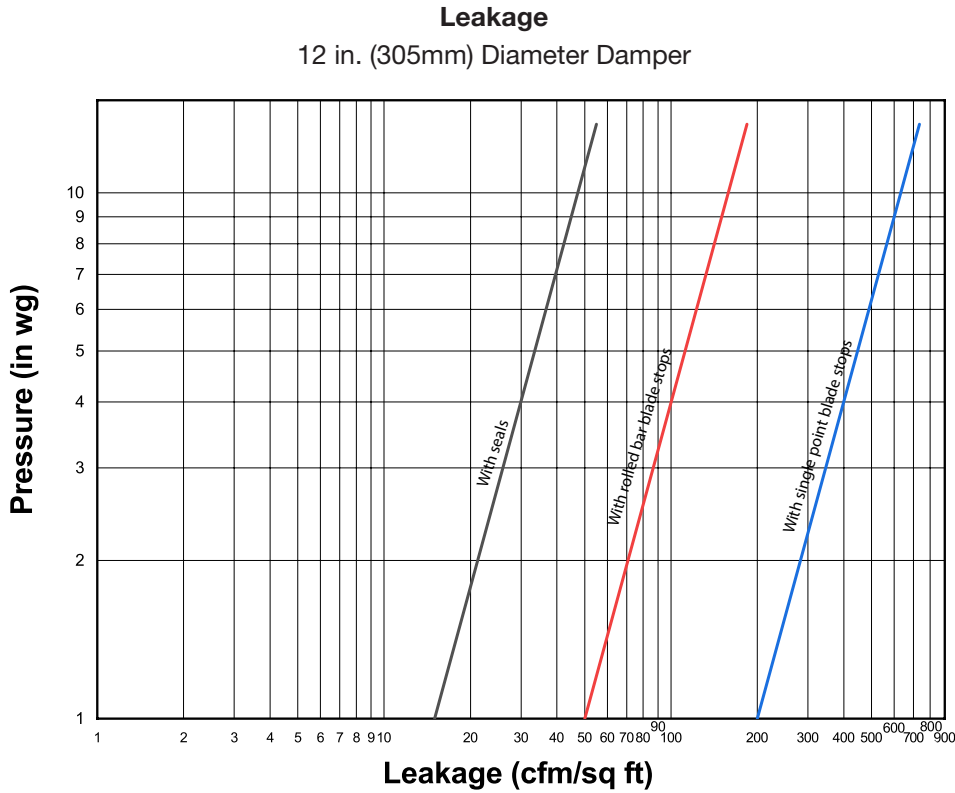

## Specifications

Industrial grade control dampers meeting the following specifications shall be furnished and installed where shown on plans and/or as described in schedules.

Dampers shall consist of a round channel frame, single axle, and single circular blade fabricated from steel with Hi Pro Polyester finish. Damper axle shall be continuous pivoting in externally mounted bronze bearings bolted to each side of the damper frame.

Damper manufacturer's printed application and performance data including pressure, velocity and temperature limitations shall be submitted for approval showing damper suitable for pressures to 13.5 in. wg (3.4 kPa), velocities to 5150 fpm (26.5 m/s), and temperatures to 600°F (315°C). Testing and ratings to be in accordance with AMCA Standard 500-D.

Specifier may add the following:

Dampers may be equipped with blade seals for low leakage performance. Blade seals shall be: EPDM synthetic rubber for 250°F (121°C) maximum temperature, Silicone Rubber for 400°F (204°C) maximum temperature, or fiberglass or ceramic for 600°F (315°C). Axles may also be equipped with Viton o-rings for clean air or double gland stuffing boxes.

Testing and ratings shall be per AMCA Standard 500-D.

Basis of design is model HCDR-250.

