

Application

Model HPR-120 is a heavy duty pressure relief damper with double flanged channel frame and single thickness blades. It is designed to protect HVAC systems and industrial processes by relieving air pressure. External heavy duty linkage, ball bearings, blade counterbalance, and adjustable pressure setting weights are standard.

Ratings (see page 2 for specific limitations)

Velocity

Up to 5150 fpm (26.2 m/s)

Temperature

-20° to 200°F (-29° to 93°C) with seals.

-20° to 250°F (-29° to 121°C) without seals.

Consult factory for temperatures above 250°F (121°C)

Pressure

0.1 in. wg (0.025 kPa) minimum;

1.0 in. wg (0.249 kPa) maximum

Back Pressure

5 - 8.5 in. wg (1.24 - 2.11 kPa)

Size Limitations

W x H	Minimum Size	Maximum Size	
		Single Section	Multi - Section
Inches	6 x 6	48 x 96	96 x 96
mm	152 x 152	1219 x 2438	2438 x 2438

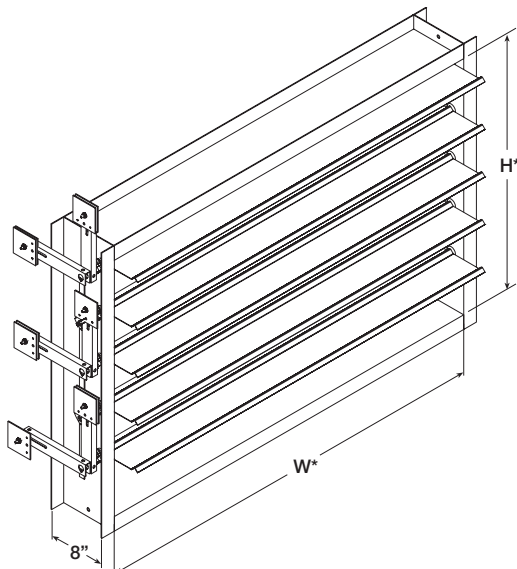

Actual Inside Dimension.

** RH counterbalance and pressure settings are standard.

*** Counterbalance and pressure setting weights extend beyond flanges in the open/closed positions.



Construction

	Standard	Optional
Frame Depth	8 in. (203 mm)	8 in. - 12 in. (203 mm - 305 mm)
Frame Material	Galvanized steel	304SS, 316SS, Carbon steel
Frame Type	Flanged channel	
Frame Thickness	14 ga. (2 mm)	10 ga. (3.5 mm), 12 ga. (2.7 mm)
Flange Width	2 in. (51 mm)	1½ in. (38 mm)
Blade Material	Galvanized steel	304SS, 316SS, Galvanneal
Blade Seals	TPE	None
Blade Thickness	16 ga. (1.5 mm)	-
Blade Type	2V	
Linkage	External heavy duty type with galvanized steel clevis arms and plated steel tie bars & pivot pins with nylon pivot bearings	304SS, 316SS
Axle Diameter	¾ in. (19 mm)	-
Axle Bearing	Galvanized ball	-
Axle Material	Plated steel	316SS
Pressure set	Adjustable arms and weights	
Paint Finishes	None	Epoxy, Hi Pro Polyester, Industrial Epoxy
Mounting Holes	None	Standard, Standard with corner holes
Airflow	Horizontal, Vertical Up, or Vertical Down	

Counterbalance & Pressure Setting Weight Dimensions

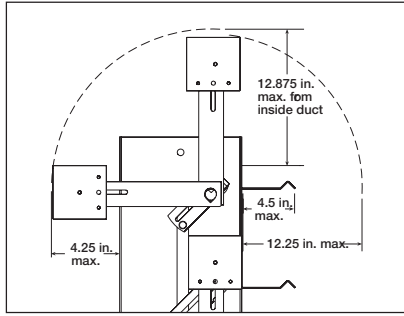

Side View

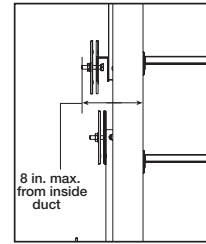

Front View

Advise air flow direction, relief pressure, & counterbalance weight location when ordering

Multi Section Assembly

Damper sizes larger than 48 in. x 96 in. (1219mm x 2438mm) and less than 96 in. x 96 in. (2438mm x 2438mm) will be supplied in one frame with two sets of blades separated by a mullion as shown below. Counterbalance and pressure set weights supplied on right hand and left hand side. For sizes larger than 96 in. x 96 in. (2438mm x 2438mm), consult factory.

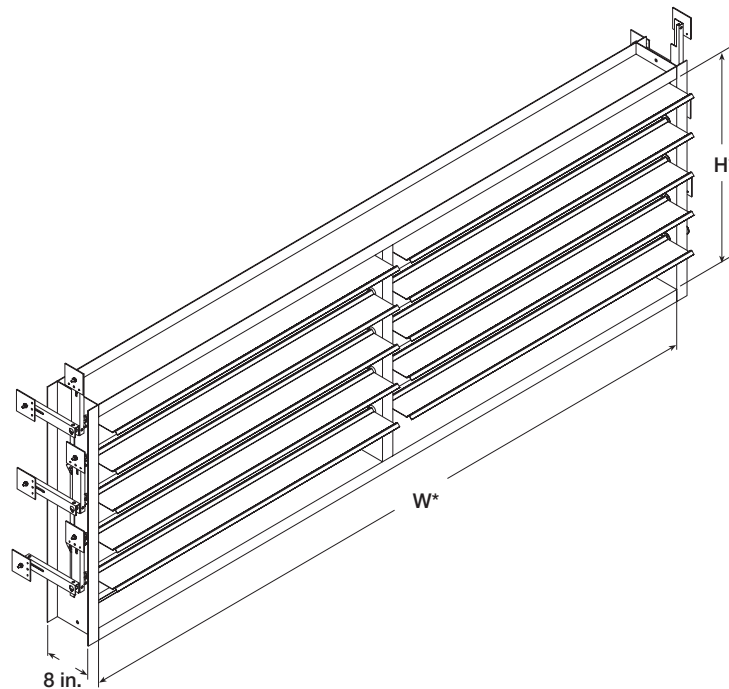

Performance Data

Back Pressure Limitations

The chart at the right shows conservative pressure limitations based on a maximum blade deflection of w/360.

Temperature Limitations

- TPE blade seals:** 20°F to 200°F (-7°C to 93°C)
- No seals:** -20°F to 250°F (-29°C to 121°C)

Velocity Limitations

The chart at far right shows conservative velocity limitations based on damper size.

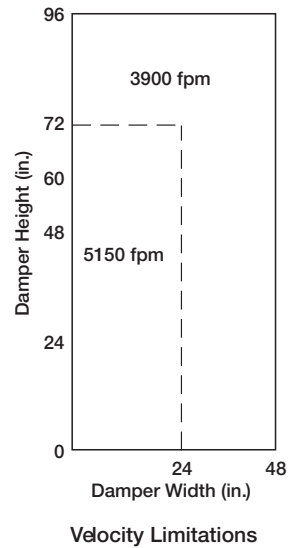
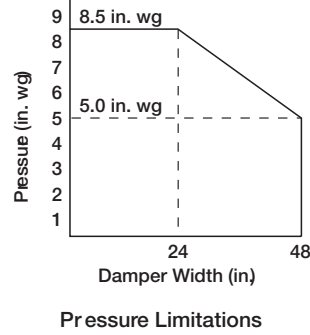

AMCA Test Figure

Figure 5.5 illustrates a plenum mounted damper. This configuration has high pressure drop because of entrance and exit losses due to the sudden changes of area in the system.

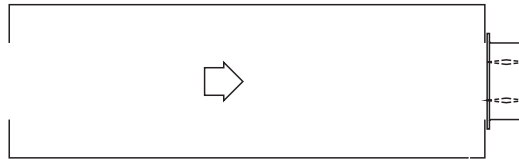

Pressure Relief/Leakage Data

This pressure drop data was conducted in accordance with AMCA Standard 500-D using the configuration shown. All data has been corrected to represent standard air at a density of 0.075 lb/ft³ (1.2 kg/m³). (The HB-120 data was included as a reference.)

Pressure Relief
24 in. x 24 in. (610mm x 610mm) Damper

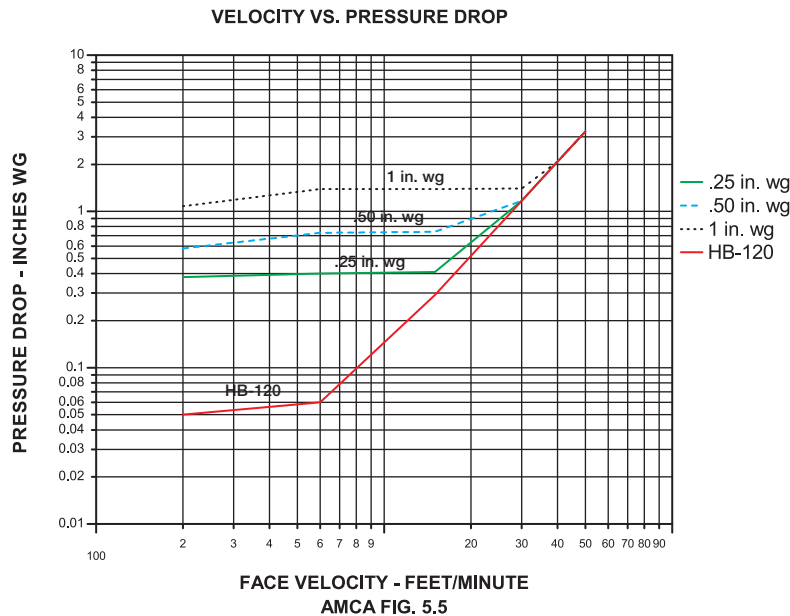

Mounting Holes

Bolt holes are available as an option. The standard pattern is 7/16 in. (11mm) diameter holes (M dimension) spaced 6 in. (152mm) on center (L dimension). Custom bolt hole pattern is available within the limitations of the chart below.

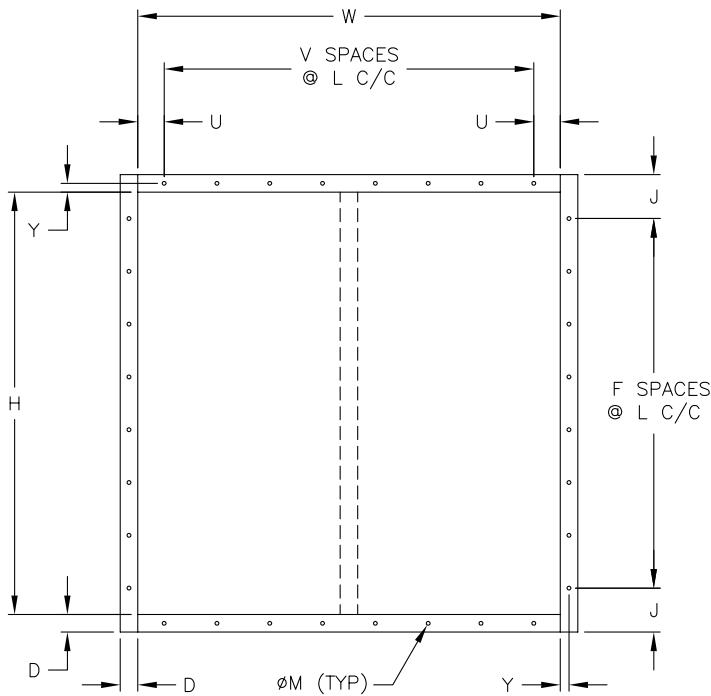

Standard Mounting Hole Pattern
Typical for single or double wide panel

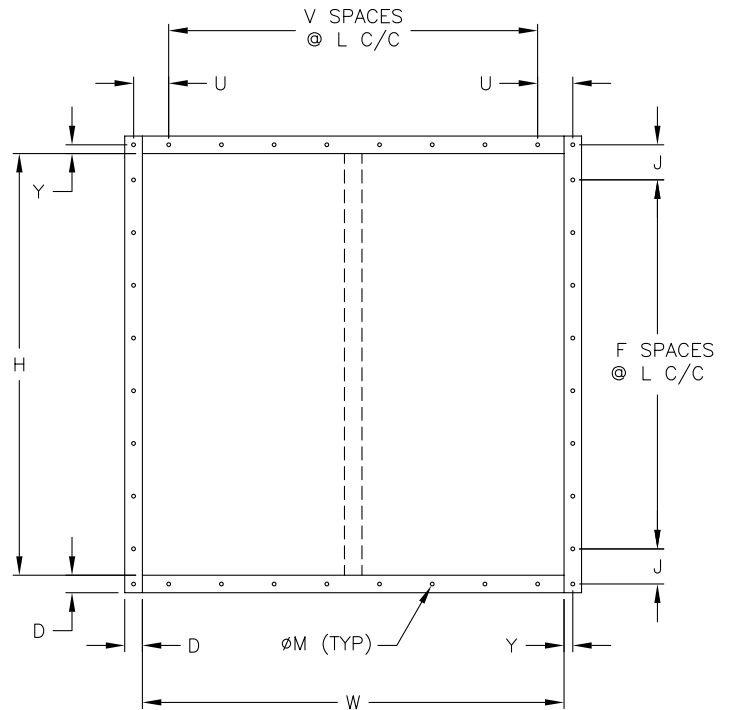

Standard Mounting Hole Pattern with Corner Holes
Typical for single or double wide panel

Document Links

[Installation Instructions](#)



[Heavy Duty/Industrial Damper Catalog](#)



[Heavy Duty and Industrial Product Selection Guide](#)



[Damper Interactive Selection Guide](#)



[Specifications](#)



[Warranty](#)

