

Application

Model HTD-636 is a heavy duty flanged frame style industrial control damper qualified for use in tunnel and transit systems. The airfoil blades, silicone blade seals, and stainless steel jamb seals meet the demanding requirements for strength and operability to standards such as NFPA-130 and 502. The leakage of the HTD-636 meets UL Class I at 12 in wg.

HTD-636 has been tested in accordance with BS476 to 2 hours at Warrington Fire, UK, and is approved for fire partitions of 4 hours or less where British Standards are required.

Ratings

Fire

BS476, Two hours

Velocity

Up to 4000 fpm (20.3 m/s)

Temperature

482°F (250°C) for 2 hours (NFPA 130, 502);
572°F (300°C) for 1 hour; 752°F (400°C) for 1 hour

Pressure

Up to 24 in. wg (6 kPa) - differential pressure

Fatigue Cycles

8 million reverse cycles at 24 in. wg (6kPa)

Size Limitations

The following table provides minimum and maximum single section size. Multiple sections can be linked together to create larger damper assemblies.

Single Section Size

Minimum	12 in. W x 12 in. H (305mm x 305mm)
Typical Maximum	48 in. W x 96 in. H (1219mm x 2438mm)

Options

- Wide range of electric and pneumatic actuators available, including high temp applications
- High Temp Limit Switches
- Multiple panel assemblies
- Mounting holes in flanges
- Perimeter gaskets
- Rubbish screens
- Junction boxes with factory wiring

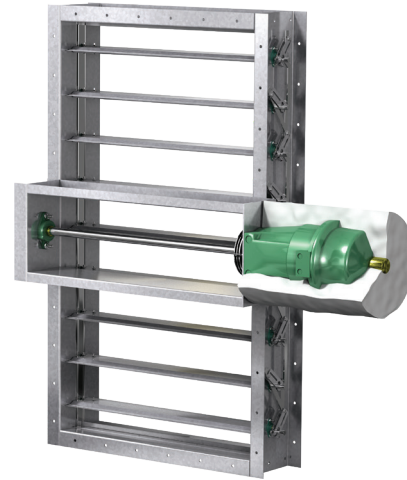

*Actual inside dimensions.

Construction

	Standard	Optional
Frame Depth	12 in. (305 mm)	-
Frame Material	Galvanized (ASTM A653)	304SS, 316SS
Frame Thickness	12 ga. (2.7 mm)	14 ga. (2mm) 10 ga. (3.4 mm) 0.25 in. (6.4 mm) 0.188 in. (4.8 mm)
Flange Width	2 in. (51 mm)	-
Blade Action	Parallel	-
Blade Deflection	L/180	L/360
Blade Material	Galvanized steel (ASTM A653)	304SS, 316SS
Blade Seals	Silicone	-
Blade Thickness	14 ga. (2 mm)	12 ga. (2.7 mm) 10 ga. (3.5 mm)
Blade Type	Fire rated double skin airfoil	
Linkage	External industrial type zinc plated steel	-
Axle Diameter	¾ in. (19 mm)	-
Axle Bearing	Stainless steel sleeve	-
Axle Material	Zinc plated steel	-
Axle Seal	None	-
Axle Type	Stub	-
Jamb Seal	Compression type stainless steel	-

Assembly

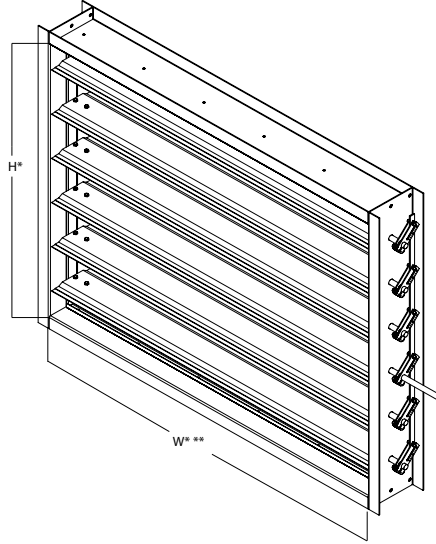

* Actual Inside Dimension

** The W dimension is ALWAYS parallel with the damper blade length.

Multiple Panel Assemblies

Multiple panels can be stacked on top of each other and side-by-side to span opening that are larger than the maximum single panel damper. Jackshafting can be added to couple multiple panels, allowing them to be operated using a single actuator. Consult the factory for design assistance for multiple panel assemblies.



**3 sections wide
1 section high**



**3 sections wide
2 sections high**

Pressure Drop Data

This pressure drop data was conducted in accordance with AMCA Standard 500-D using the two configurations shown. All data has been corrected to represent standard air at a density of .075 lb./ft³ (1.2 kg/m³).

Actual pressure drop found in any HVAC system is a combination of many factors. This pressure drop information along with an analysis of other system influences should be used to estimate actual pressure losses for a damper installed in a given HVAC system.

AMCA Test Figures

Figure 5.3 Illustrates a fully ducted damper. This configuration has the lowest pressure drop of the two test configurations because entrance and exit losses are minimized by straight duct runs upstream and downstream of the damper.

Figure 5.2 Illustrates a ducted damper exhausting air into an open area.

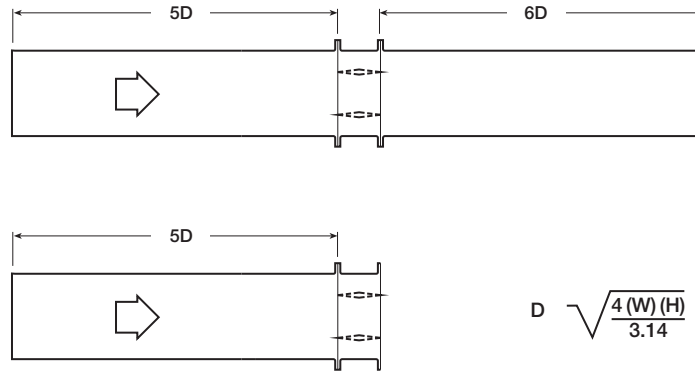

Pressure Drop (english version)
42 in. x 42 in. (1067mm x 1067mm) Damper

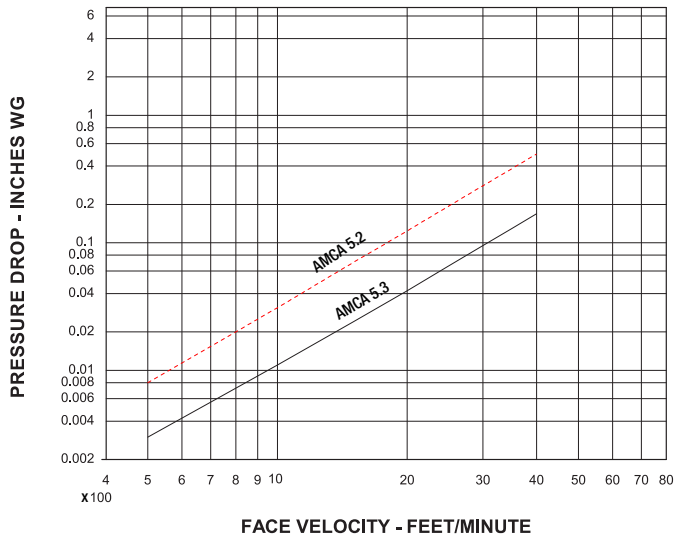

Pressure Drop (metric version)
42 in. x 42 in. (1067mm x 1067mm) Damper

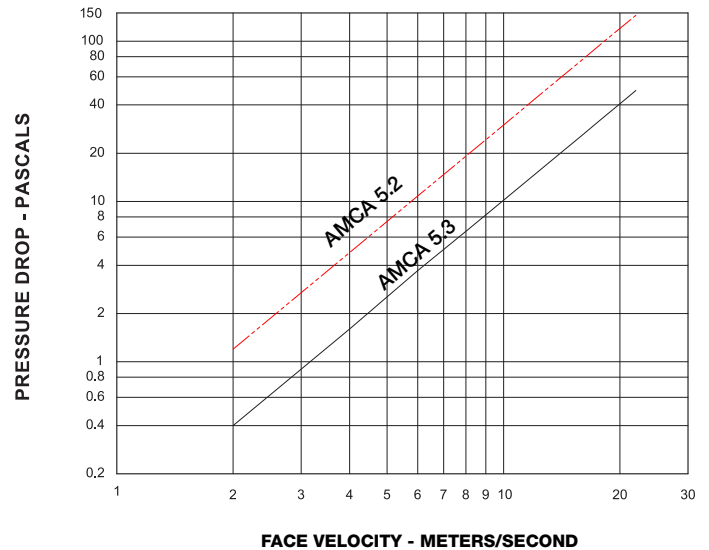

Leakage

Damper leakage (with blades fully closed) varies based on the type of low leakage seals applied. Leakage testing was conducted in accordance with AMCA Standard 500-D and is expressed as CFM per sq. ft. of damper face area. All data has been corrected to represent standard air at a density of .075 lb./ft³ (1.2 kg/m³).

Leakage (english version)

42 in. x 42 in. (1067mm x 1067mm) Damper

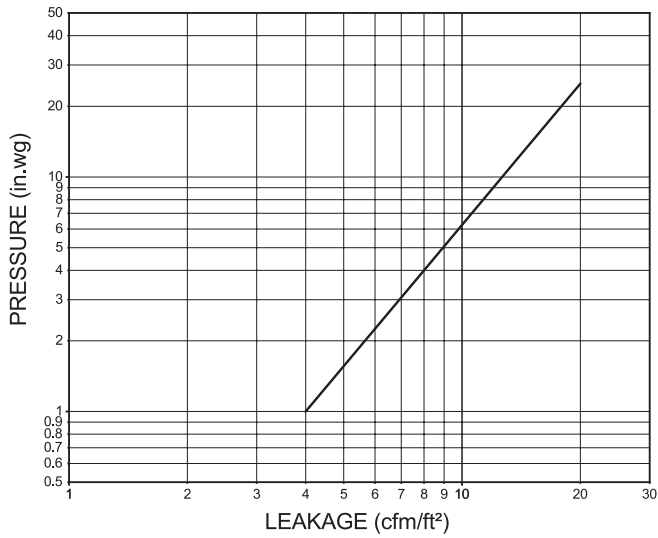

Leakage (metric version)

42 in. x 42 in. (1067mm x 1067mm) Damper

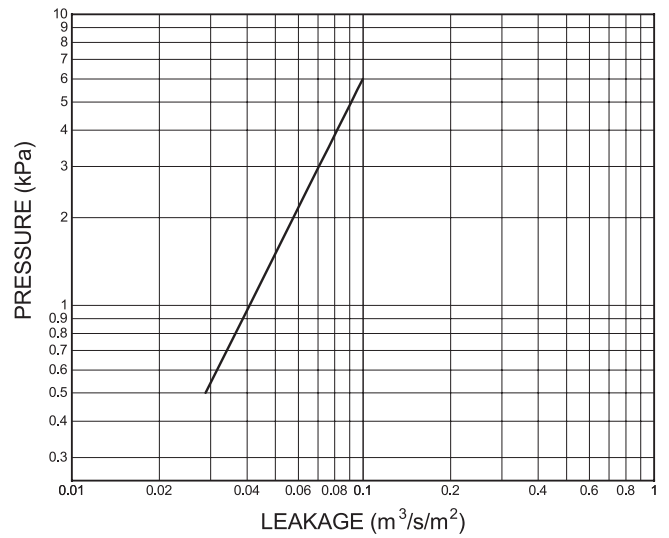

Document Links

[Installation Instructions](#)



[Heavy Duty/Industrial Damper Catalog](#)



[Tunnel Transit](#)



[Damper Interactive Selection Guide](#)



[Warranty](#)

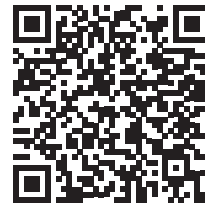

Specifications

Industrial grade control dampers meeting the following specifications shall be furnished and installed where shown on plans and/or as described in schedules.

Dampers shall consist of: a 12 ga. (2.7mm) galvanized steel channel frame with 12 in. (305mm) maximum depth and 2 in. (51mm) flanges; double skin airfoil type blades fabricated from two layers of 14 ga. (2mm) galvanized steel; $\frac{3}{4}$ in. (19mm) dia. plated steel axles turning in oil impregnated sintered stainless steel bearings press-fit into frame; and external (out of the airstream) blade-to-blade linkage. Blade seals shall be silicone rubber and jamb seals shall be flexible stainless steel.

Damper manufacturer's printed application and performance data including pressure, velocity and temperature limitations shall be submitted for approval showing damper suitable for pressures to 24 in. wg (6 kPa), velocities to 4000 fpm (20.3 m/s) and temperatures to 482°F (250°C). Testing and ratings to be in accordance with AMCA Standard 500-D.

Dampers shall be tested in accordance with BS476 to 2 hours and approved for fire partitions of 2 hours or less where British Standards are required.

Basis of design is Greenheck model HTD-636.

