

## Application

Model HTGR-250 is heavy duty industrial round toxic gas damper with a flanged frame

## Ratings

### Velocity

Up to 4000 fpm (20.3 m/s)

### Temperature

-40° to 250°F (-40° to 121°C)

### Pressure

Up to 13.5 in. wg (3.4 kPa) - differential pressure

## Construction

	Standard	Optional
<b>Frame Material</b>	316SS	304SS, Galvanized steel
<b>Frame Type</b>	Flanged channel	
<b>Blade Material</b>	316SS	304SS, Galvanized steel
<b>Blade Seals</b>	EPDM	Silicone, None
<b>Blade Stops</b>	Rolled Bar	-
<b>Axle Bearing</b>	External Bronze	-
<b>Axle Material</b>	316SS	303SS, Plated steel
<b>Axle Seals</b>	None	-
<b>Paint Finishes</b>	None	-
<b>Mounting Holes</b>	Yes	-
<b>Actuator</b>	Manual Quadrant	Schischek InMax-15-SF-S7 (24V - 230V)



\*Actual inside dimension.

Model HTGR-250 toxic gas damper meets the requirements established by:

**United States Department of the Navy**  
 MIL-S-901D Shock Tests, High Impact Shipboard Machinery,  
 Equipment, and Systems

4130 Ser 501/1942 (24 Aug 16)

Test Category: Medium Weight, Shock Grade A

## Features:

- When actuator is supplied, NEMA 4X enclosure is included.

## Size Limitations

W x H	Minimum Size	Maximum Size
Inches	5	20
mm	127	508

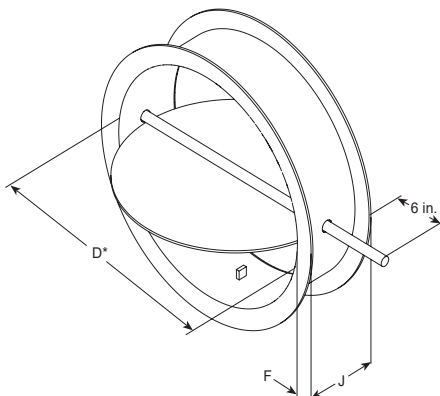

Diameter D Inches (mm)		Frame Depth J Inches (mm)	Frame & Flange Gauge (mm)	Flange Width F Inches (mm)	Axle Diameter Inches (mm)	Blade Thickness Gauge (mm)
Above	Through					
5 (127)	6 (152)	8 (203)	10 (3.5)	1.25 (32)	0.5 (13)	10 (3.5)
6 (152)	8 (203)	8 (203)	10 (3.5)	1.25 (32)	0.75 (19)	10 (3.5)
8 (203)	10 (254)	8 (203)	10 (3.5)	1.5 (38)	0.75 (19)	10 (3.5)
10 (254)	20 (508)	8 (203)	0.188 (4.8)	1.5 (38)	0.75 (19)	0.188 (4.8)

# Performance

## AMCA Test Figure 5.3

Figure 5.3 illustrates a fully ducted damper. This configuration has low pressure drop because entrance and exit losses are minimized by straight duct runs upstream and downstream of the damper.

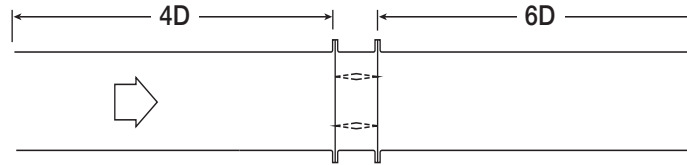

Fig. 5.3

## Pressure Drop Data

This pressure drop data was conducted in accordance with AMCA Standard 500-D using Test Figure 5.3. All data has been corrected to represent standard air at a density of 0.075 lb/ft<sup>3</sup> (1.2 kg/m<sup>3</sup>).

Actual pressure drop found in any HVAC system is a combination of many factors. This pressure drop information along with an analysis of other system influences should be used to estimate actual pressure losses for a damper installed in a given HVAC system.

## Leakage Data

Damper leakage (with blades fully closed) varies based on the type of blade stops and low leakage seals applied. Model HTGR-250 is available with EPDM or silicone rubber blade seals. Leakage testing was conducted in accordance with AMCA Standard 500-D and is expressed as cfm/ft<sup>2</sup> of damper face area. All data has been corrected to represent standard air at a density of 0.075 lb/ft<sup>3</sup> (1.2 kg/m<sup>3</sup>).

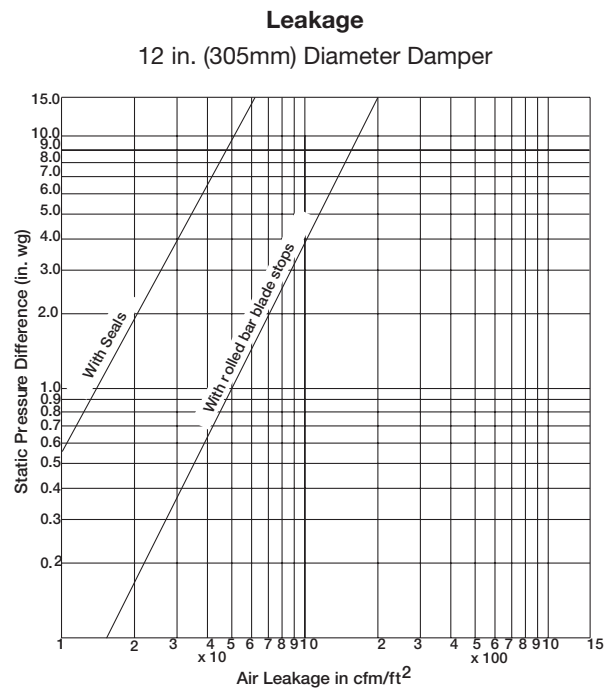
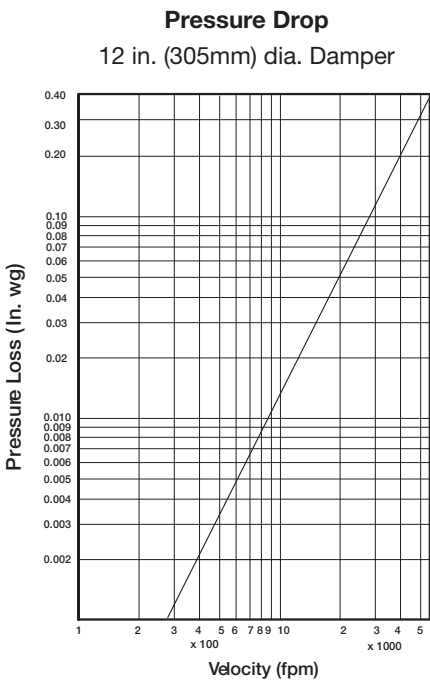

## Options

### Bearing

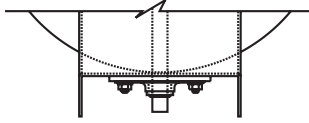

Bronze Sleeve

### Blade Seal Options (Rolled Bar Blade Stops Required)

**Optional** - EPDM Blade Seals (250°F [121°C] max.) or Silicone Rubber Blade Seals (400°F [204°C] max.)

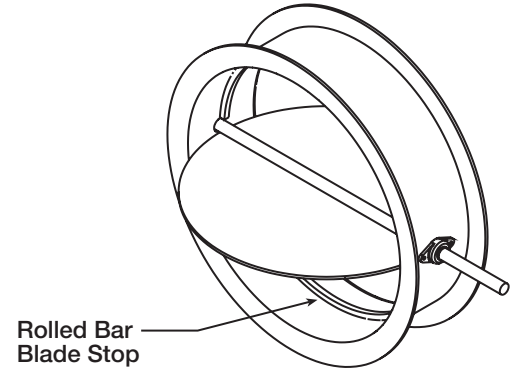

Rolled Bar Blade Stop

### Mounting Holes

Greenheck recommended bolt hole pattern is shown in the table below. Customer must specify bolt holes that are parallel to the axle centerline (P) or that straddle the axle centerline (S) as shown in the diagrams below. Greenheck can also provide bolt hole sizes and patterns other than those shown.

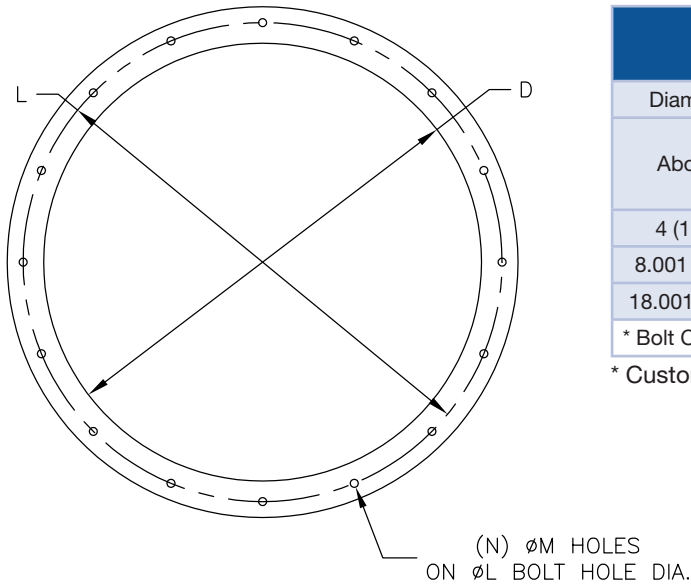

Greenheck Recommended Bolt Hole Pattern (Bolt Holes Parallel to Axle Centerline)					
Diameter Inches (mm)		Number of Holes	Mounting Hole Diameter in. (mm) N	Bolt Circle Diameter L	Degrees Between Holes
Above	Through				
4 (102)	8 (203)	8	3/8 (9.5)	*	90
8.001 (203)	18 (457)	12	7/16 (11)	*	45
18.001 (457)	20 (508)	16	7/16 (11)	*	30

\* Bolt Circle Diameter = Damper Diameter + Flange Height + 1/4 in. (6mm)

\* Custom bolt hole patterns are available, consult factory.

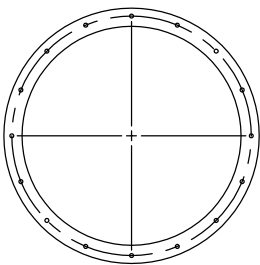

On Centerline

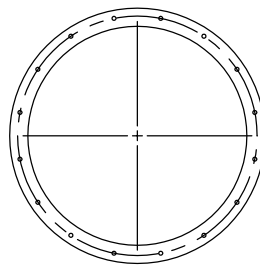

Straddle Centerline

[Heavy Duty/Industrial Damper Catalog](#)



[Damper Interactive Selection Guide](#)



[Warranty](#)

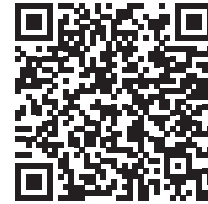

## Specifications

Industrial grade toxic gas dampers meeting the following specifications shall be furnished and installed where shown on plans and/or as described in schedules.

Dampers shall meet the requirements of the United States Department of the Navy; MIL-S-901D Shock Tests, High Impact Shipboard Machinery, Equipment, and Systems (4130 Ser 501/1942); and Test Category: Medium Weight, Shock Grade A.

Dampers shall consist of a round channel frame, single axle, and single circular blade all 316 stainless steel; blade shall have an EPDM blade seal. Damper axle shall be continuous pivoting in externally mounted bronze sleeve bearings bolted to each side of the damper frame. Damper actuator shall be a manual quadrant.

Damper manufacturer's printed application and performance data including pressure, velocity and temperature limitations shall be submitted for approval showing damper suitable for pressures to 13.5 in. wg (3.4 kPa), velocities to 4,000 fpm (20.3 m/s), and temperatures to 400°F (204°C).

Specifier may add the following:

Dampers may be equipped with blade seals for low leakage performance. Blade seals shall be: EPDM synthetic rubber for 250°F (121°C) maximum temperature, or Silicone Rubber for 400°F (204°C) maximum temperature.

Testing and ratings shall be per AMCA Standard 500-D.

Basis of design is Greenheck model HTGR-250.